













# ATLAS

ZUR

## ZEITSCHRIFT FÜR BAUWESEN.

HERAUSGEGEBEN

UNTER MITWIRKUNG DER KÖNIGL. TECHNISCHEN BAU-DEPUTATION UND DES  
ARCHITEKTEN-VEREINS ZU BERLIN.

REDIGIRT

VON

**G. ERBKAM,**

KÖNIGLICHEM BAU-INSPEKTOR IM MINISTERIUM FÜR HANDEL, GEWERBE UND ÖFFENTLICHE ARBEITEN.



**JAHRGANG IV.**

1911. 1702.



3420

BERLIN, 1854.  
VERLAG VON ERNST & KORN.  
(GROPIUS'SCHE BUCH- UND KUNSTHANDLUNG.)

Abgegeben  
von der  
Bücherei  
der Königl. Technischen  
Hochschule Danzig.



# I N H A L T:

No. der Blätter.	Gegenstand.	No. der Blätter.	Gegenstand.
1.	Circus Napoléon zu Paris. Grundrisse in 4 verschiedenen Höhen.	37.	M. Bewegliche Baugerüste zu Paris. (Im Text zu S. 296.)
2.	Derselbe. Ansicht und Durchschnitt.		Gas-Anstalt zu Magdeburg. Querdurchschnitt des Gasometer-Gebäudes und des Feuerungs-Gebäudes, Grundrifs des Gasometers.
3.	Derselbe. Details der Façade und Profil der Umfassungsmauer.	38.	Dieselbe. Profile des Kohlenschuppens, Grundrifs, Längen- und Querprofil der Windevorrichtung, Querdurchschnitt des Reinigungs-Gebäudes, Vorder- und Hinter-Ansicht nebst Längen-Durchschnitt eines Ofens.
4.	Derselbe. Details der inneren Decoration.		
A.	Derselbe. Details des Dachverbandes und eines hölzernen Dachbinders. (Im Text zu S. 4.)	39.	Dieselbe. Gaspumpe, Regulator, Wechselhahn im Gasometer-Gebäude, desgl. im Reinigungs-Gebäude und Vorgelege.
5.	Elbbrücke bei Wittenberge. Elbstrom-Karte von Belau bis Müggendorf.	40.	Eisenbahn-Wagenbau-Werkstatt des Herrn Pflug zu Berlin. Façade.
6.	Dieselbe. Situationsplan nebst 2 Peilungs-Profilen.	41.	Dieselbe. Grundrifs und 2 Profile.
7.	Dieselbe. Das Project, nach welchem die Ausführung begonnen, und das Project, nach welchem sie vollendet worden ist.	N.	Dieselbe. Details. (Im Text zu S. 348.)
8.	Hydraulische Winde-Vorrichtung zu Hamburg. Durchschnitt des Güterschuppens, Grundrifs und Seiten-Ansicht der ganzen Anlage.	O.	Bogenbinder über den Sitzungssaal des II. Kammer-Gebäudes. (Im Text zu S. 351.)
9.	Dieselbe. Grundrifs u. Seiten-Ansicht der Maschine.	42.	Scheune auf dem Rittergut Stechau bei Herzberg a. d. schwarzen Elster.
10.	Dieselbe. Vorder-Ansicht der Maschine und Details.	43.	Eiserner Dachverband auf dem Strafsburger Eisenbahnhof zu Paris.
B.	Dieselbe. Kolbenhubzähler und Druckmesser. (Im Text zu S. 53.)	44.	Eiserner Dachverband auf dem Lyoner Eisenbahnhof zu Paris.
11.	Kloster Chorin. Situationsplan und Grundrifs.	45.	Die neue Leesenbrück'sche Schleuse. Die Betriebs-Arche derselben.
12.	Dasselbe. 2 Seiten-Ansichten u. eine Giebel-Ansicht.	46.	Dieselbe. Das Pumpwerk in Ansichten und Details.
13.	Dasselbe. 3 Giebel-Ansichten nebst Details derselben.	47.	Dieselbe. Grundrisse, Längen- u. Querdurchschnitte derselben.
C.	Dachfenster-Constructionen ohne Kittverglasung. (Im Text zu S. 75.)	48.	Dieselbe. Details.
14.	Kloster Chorin. Perspectivische Ansicht, von der Nordwestseite aus genommen.	P.	Dieselbe. Situationsplan. (Im Text zu S. 379.)
15.	Dasselbe. 2 Giebel nebst Details, Grundrifs und Ansicht des Portals, 4 Thürkapitäl, Gewölbekappe mit Fresken und Details zum Giebel, Fig. 6, Blatt 13.	Q.	Dieselbe. Details der Pumpen. (Im Text zu S. 380.)
16.	Dasselbe. 4 Profile der Pfeiler des Mittelschiffs, deren Basen und Kapitäl, Profil des Eckpfeilers vom Kreuze, Grundrifs eines Fensters der westlichen Front, Consolen im Mittelschiff und zu Gewölbe-Anfängern, Basen und Kapitäl dazu.	R.	Dieselbe. Die Schleusenthore und Drempel. (Im Text zu S. 385.)
17.	Dasselbe. Ansichten der Fenster im Mittelschiff und im westlichen Giebel, Hauptgesims im Mittelschiff, Friese, Profile verschiedener Fenster.	S.	Dieselbe. Details der Umläufe. (Im Text zu S. 388.)
18.	Erbgräbnifs in Ramstedt bei Magdeburg.	49.	Fluthschleuse und Fahrbrücke am Hüttenteiche zu Reilswerk in Ober-Schlesien. Längenprofil, Querprofil und Grundrifs.
19.	Irren-Anstalt zu Schwetz, Situationsplan.	T.	Dieselbe. Details. (Im Text zu S. 393.)
20.	Dieselbe. Administrations- u. Directorial-Gebäude in 2 Grundrissen, Façade, Querprofil und Details.	50.	Ueberfall oberhalb des Werkteiches zu Rybnikerhammer in Ober-Schlesien. Längenprofil, 2 Querprofile und Grundrifs.
21.	Dieselbe. Heil-Anstalt für Männer und Pflege-Anstalt für Männer, in Grundrissen, Vorder-Ansichten und Profilen.	U.	Dieselbe. Details. (Im Text zu S. 393.)
22.	Brauerei-Gebäude des Herrn E. Wagner bei Berlin, 2 Ansichten und 2 Grundrisse.	51.	Teichschleuse zu Karstenhütte bei Rybnik in Ober-Schlesien. Längenprofil, Querprofil und Grundrifs.
23.	Dasselbe. 3 Grundrisse und 2 Durchschnitte.	V.	Dieselbe. Details. (Im Text zu S. 394.)
24.	Dasselbe. Längen-Durchschnitt.	52.	Kapelle zu Drüggelte.
D.	Aufstellung der eisernen Gitterbrücke über die Saale bei Grizhna. (Im Text zu S. 168.)	53.	Kloster Huysburg. Grundrifs, Längen- und Querprofile.
E.	Brücken von Eisenblech auf der Verbindungsbahn zu Paris. Brücke über die Departemental-Straße No. 14 und Brücke über die Straße de l'Entrepôt. (Im Text zu S. 171.)	54.	Dasselbe. Situationsplan, Ansichten und Details.
F.	Dieselben. Brücke der Nordbahn. (Im Text zu S. 171.)	55.	Dasselbe. Das Bibliotheks-Gebäude, Grundrifs, Ansicht, Längen- und Querdurchschnitt, Details.
G.	Dieselben. Brücke über die Kaiserliche Straße. (Im Text zu S. 172.)	W.	Luft-Heizungs-Anlage im Arbeitshause zu Stralsund. (Im Text zu S. 407.)
H.	Dieselben. Brücke über die Straße von Aubervilliers und Brücke der Strafsburger Eisenbahn. (Im Text zu S. 173.)	X.	Graphische Darstellung der Geschwindigkeiten des Wassers in Röhren bei verschiedenen Temperaturen. (Im Text zu S. 358.)
25.	Decken-Decoration im Louvre zu Paris.	56.	Herrschaftliches Wohnhaus in Berlin. 2 Grundrisse. Façade.
26.	Kirche zu Brodowin, Grundrisse, Ansichten und Profile.	57.	Dasselbe. Durchschnitt durch den Hausflur, Ansicht des Aufbaues am Seitenflügel, Façadenprofil, Details der Fenster und des Hauptgesimses.
27.	Dieselbe. Details.	58.	Elbbrücke bei Wittenberge. Brücke über die taube Elbe. Ansicht, Grundrifs, Längen- u. Querdurchschnitte.
28.	Irren-Anstalt zu Schwetz, Gebäude für Tobsüchtige.	59.	Dieselbe. Gewölbe und Lehrbogen der Fluthbrücken. Ansicht, Querschnitt und Details der Schrauben.
29.	Dieselbe. Allgemeines Wirtschafts-Gebäude, Ansicht, Profile und Details des Hauptgebäudes.	60.	Brücke über die Nedlitz. Perspectivische Ansicht.
30.	Dieselbe. Das allgemeine Wirtschafts-Gebäude im Grundrifs, nebst Details von Wasch- und Koch-Apparaten.	Y.	Dieselbe. Ansicht u. Grundrifs.
31.	Dieselbe. Querdurchschnitte daselbst, nebst Details von Wasch-Apparaten.	61.	Fluß-Dampfbagger für die Melioration des Nieder-Oderbruchs. Längendurchschnitt u. Grundrifs des Baggers.
32.	Dieselbe. Perspectivische Ansicht der Anlage.	62.	Dieselbe. Querdurchschnitt des Baggers nebst Details.
I.	Dieselbe. Längen-Durchschnitt der Waschküche und des Dampfmaschinen-Hauses nach A, B des Grundrisses Blatt 30.	63.	Dieselbe. Ansichten, Profile und Details der Dampfmaschine.
33.	Gas-Anstalt zu Magdeburg. Situationsplan der ganzen Anlage und Details einzelner Constructionen.	Z.	Dieselbe. Längen- und Querschnitt des veränderten Baggerschiffs. (Im Text zu S. 501.)
34.	Dieselbe. Ansichten des Feuerungs-Gebäudes, des Kohlenschuppens, des Absonderungshauses, des Reinigungs-Gebäudes und des Gasometer-Gebäudes.	64.	Details aus dem Kreuzgang des Domes zu Aachen.
35.	Krahn aus Eisenblech zu Keyham in England, Ansichten und Durchschnitte des Krahns und der Windevorrichtung nebst Details.	65.	Eisenbahn von Saarbrücken nach Paris. — Situationsplan des Bahnhofes zu Metz auf der Paris-Strafsburger Eisenbahn, nebst Grundrifs und Profil durch die Personenhalle des Empfangsgebäudes daselbst.
36.	Derselbe. Ansichten, Profile, Grundrisse u. Details.	66.	Dieselbe. Gerüsthammer mit Gummifedern, Personenwagen III. Classe mit Schaffnersitz, Bordwagen mit Klappen zum Kohlen- und Gütertransport.
K.	Derselbe. Ansichten und Details der Drehvorrichtung und der Windevorrichtung. (Im Text zu S. 256.)	A'.	Dieselbe. Werkstatt zu Epernay auf d. Paris-Strafsburger Eisenbahn. (Im Text zu S. 533.)
L.	Irrenhaus zu Charenton. (Im Text zu S. 289.)	B'.	Dieselbe. Materialien-Magazin der französischen Nordbahn. Grundrifs, Querdurchschnitt desselben nebst Details eines Laufkrahn. (Im Text zu S. 535.)
		C'.	Dieselbe. Zugvorrichtung für die Signale vor den Bahnhöfen der französischen Nordbahn. (Im Text zu S. 536.)
		D'.	Dieselbe. Personenhalle der Paris-Versailer Bahn. Grundrifs, Quer- und Längendurchschnitt derselben nebst Ansicht der Buffer vor den Drehscheiben. (Im Text zu S. 538.)
		E'.	Anwendung des Eisens zum Gebäudebau. (Im Text zu S. 581.)



# Circus Napoléon zu Paris.

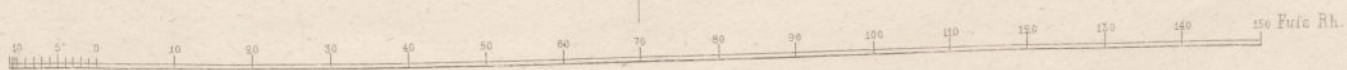
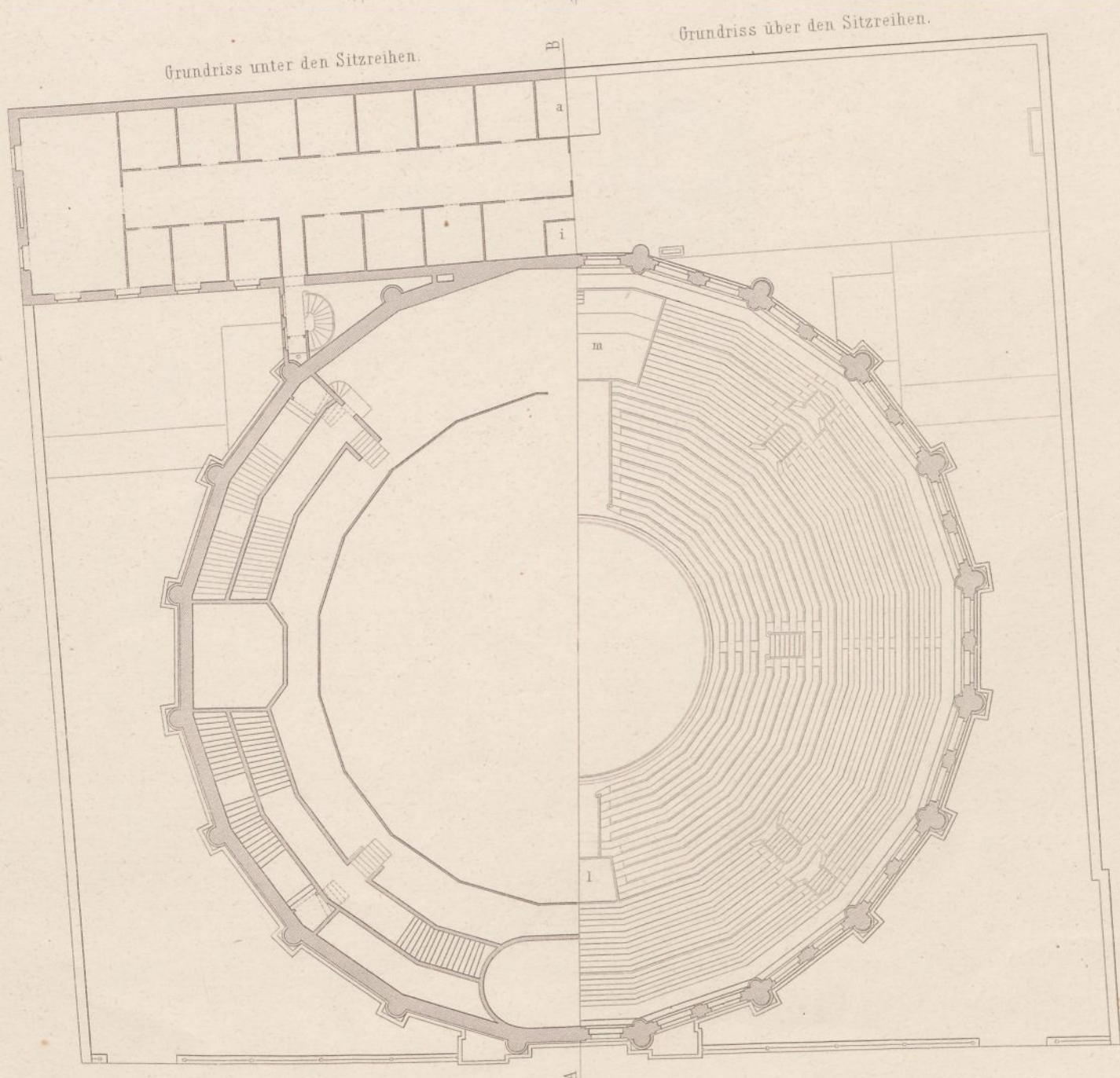
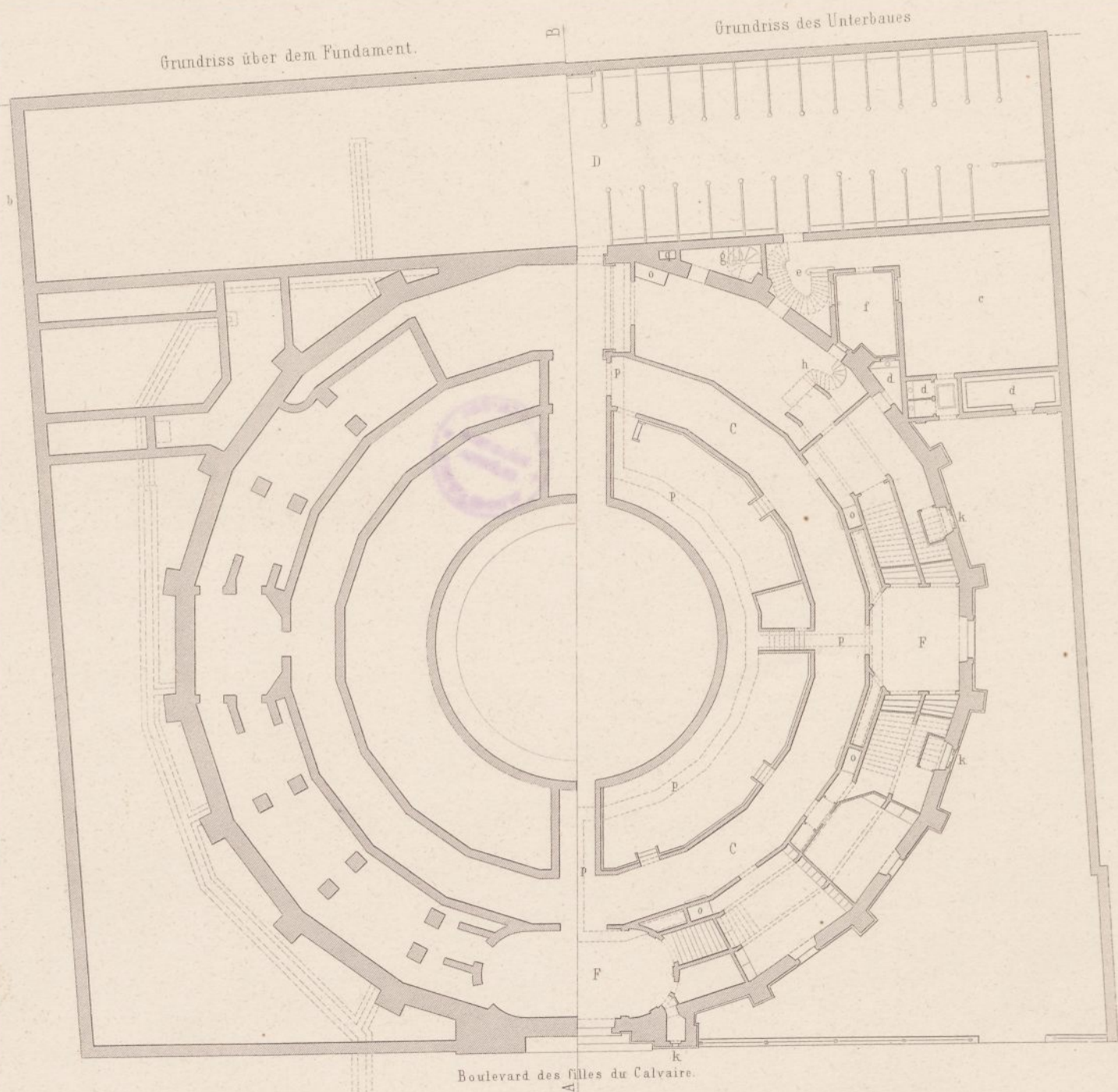

Circus Napoléon zu Paris

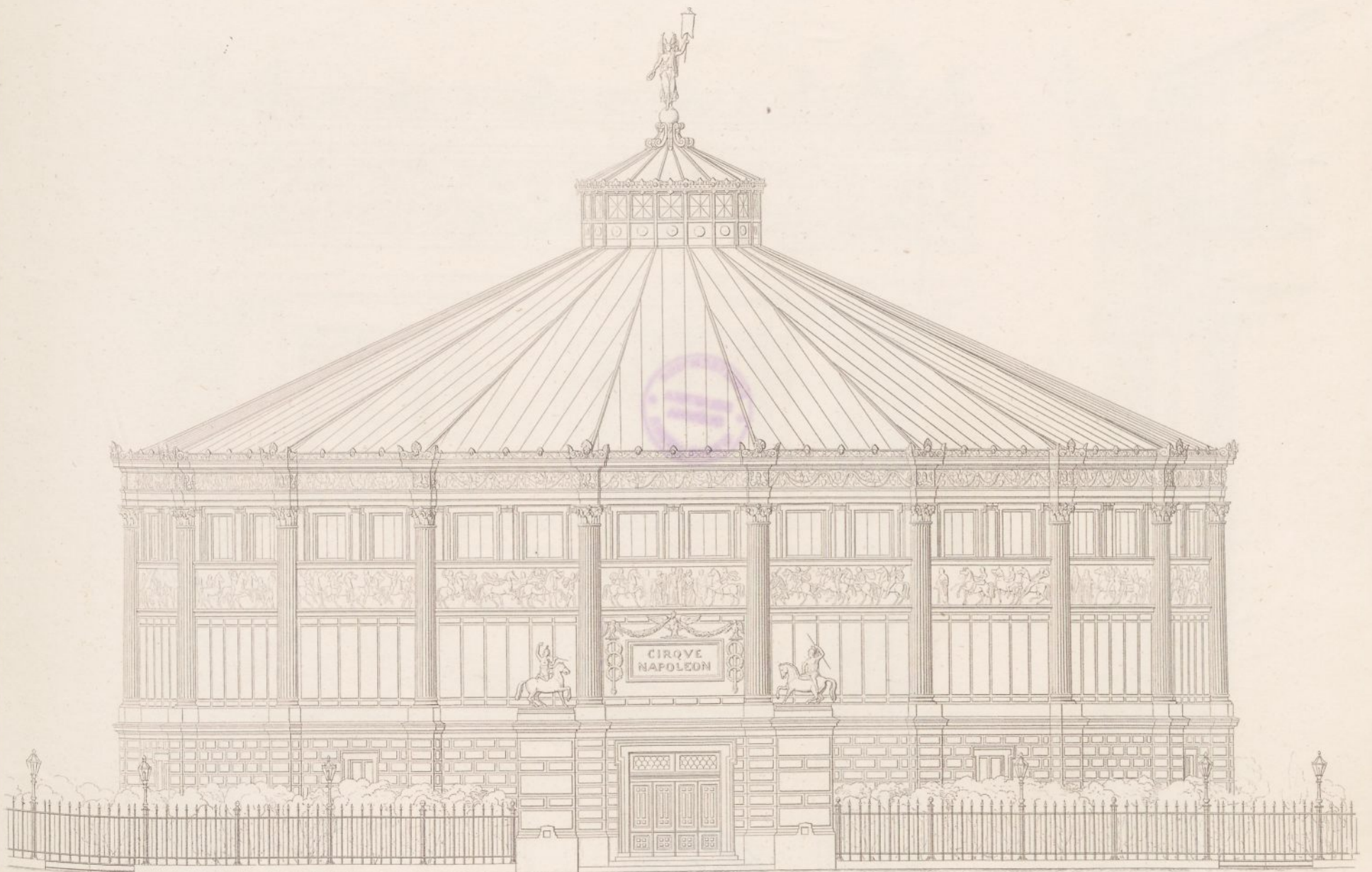

Vorderansicht

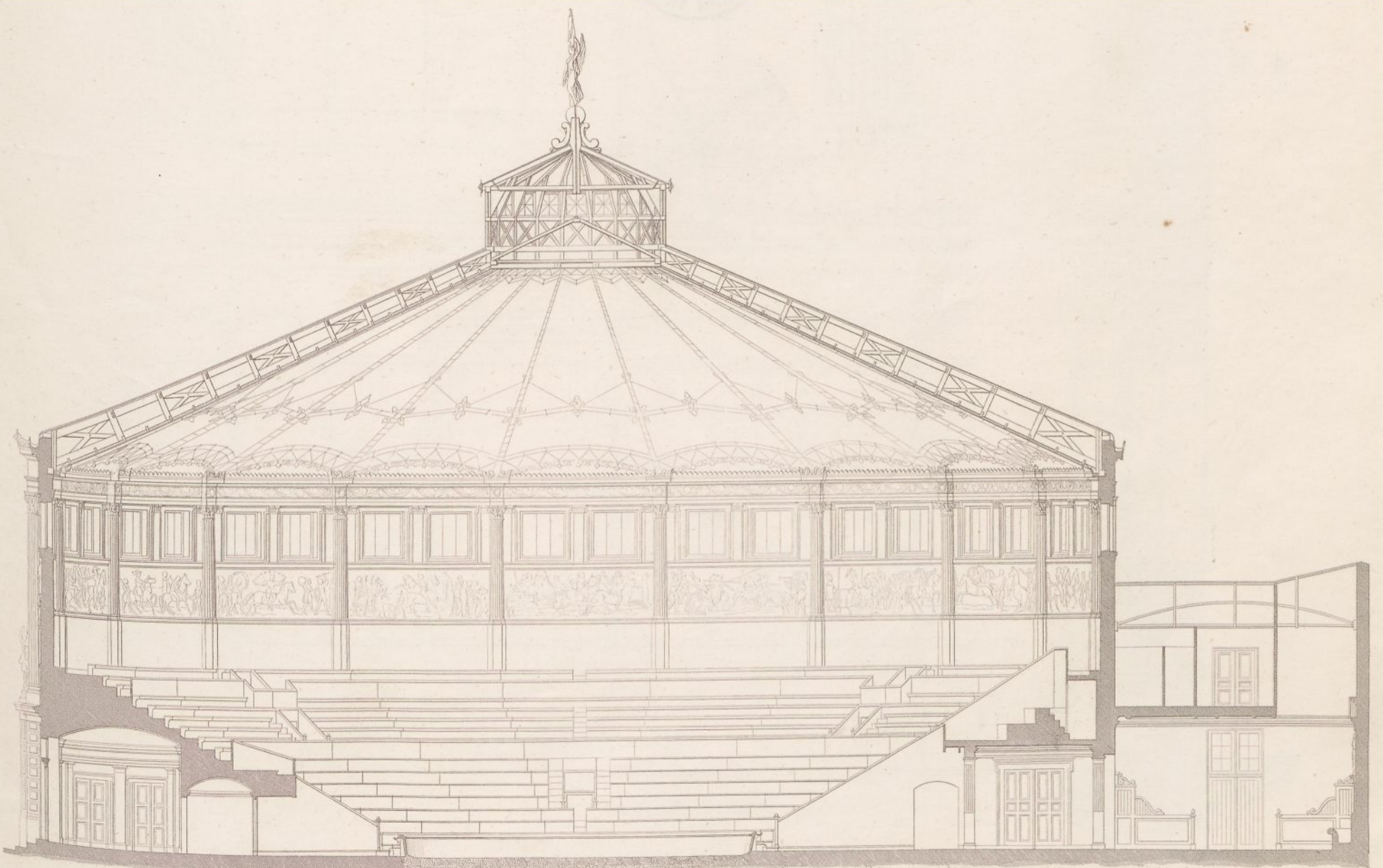

Durchschnitt nach AB.

10 5 0 10 20 30 40 50 60 70 80 90 100 Fute Rh.

Circus Napoléon zu Paris.

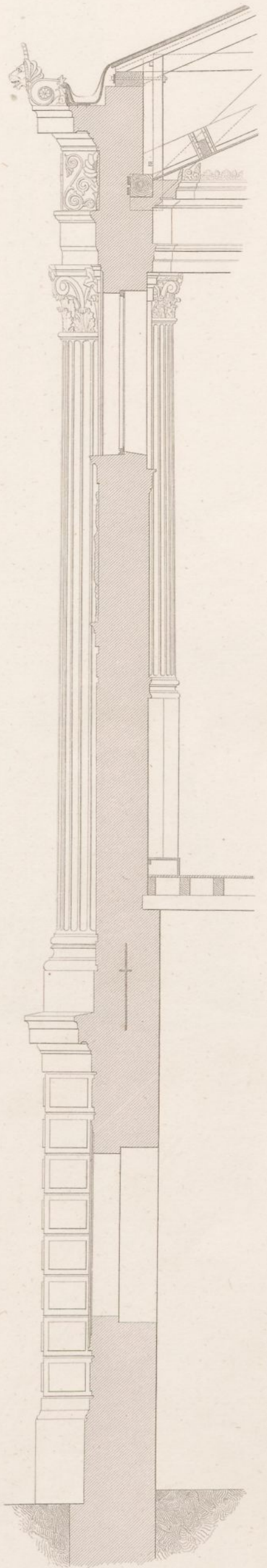

Details der Façade.

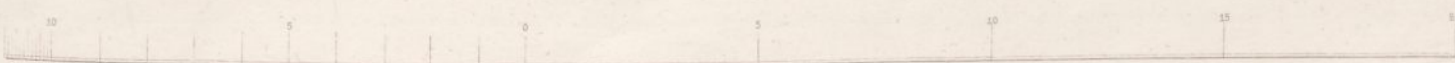

so Fuß Rh.

Circus Napoléon zu Paris.

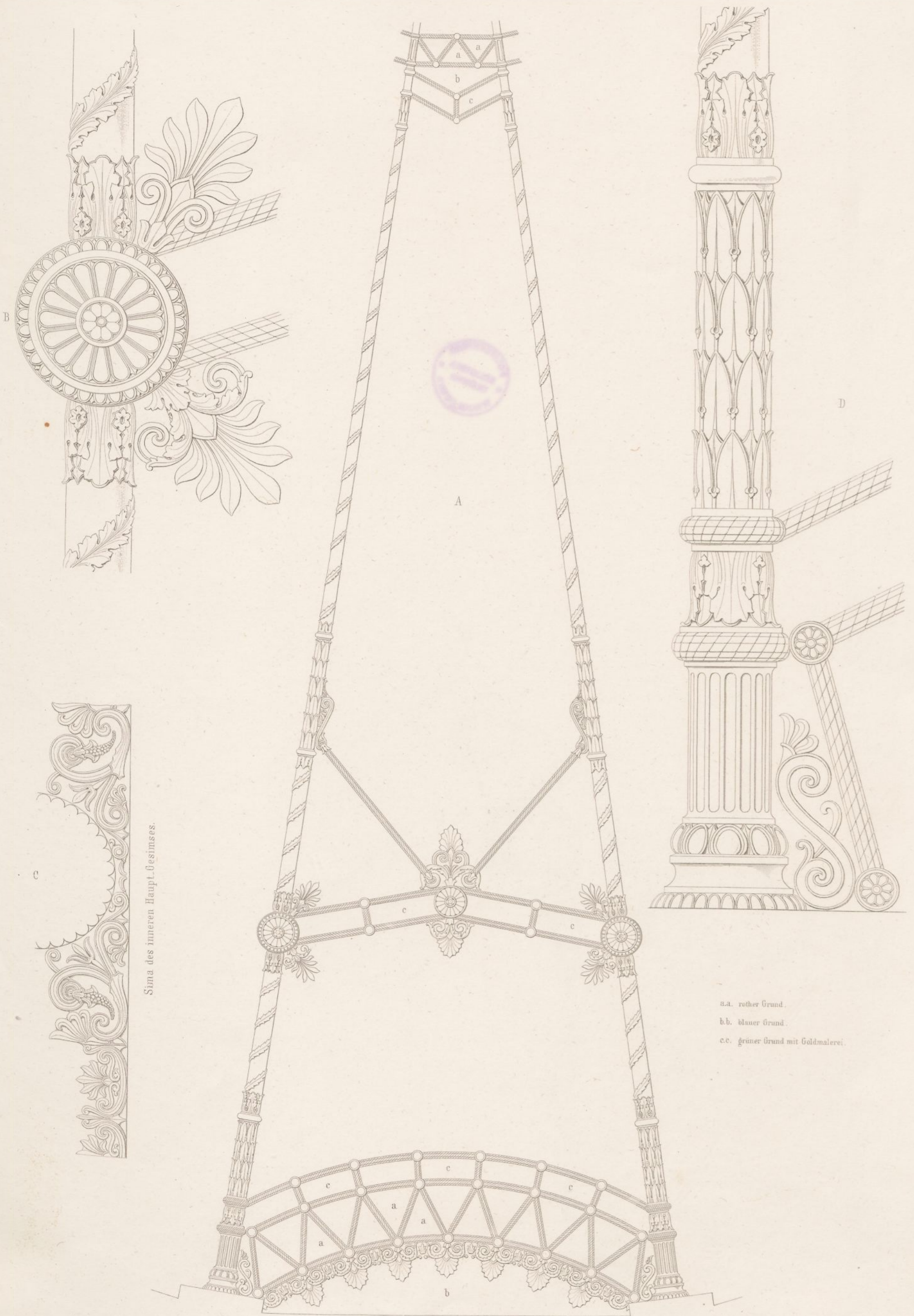

Sima des inneren Haupt-Gesimses.

a.a. rother Grund.  
 b.b. blauer Grund.  
 c.c. grüner Grund mit Goldmalerei.

Details der inneren Decoration.

zu Fig. A.



zu Fig. B. C. D.

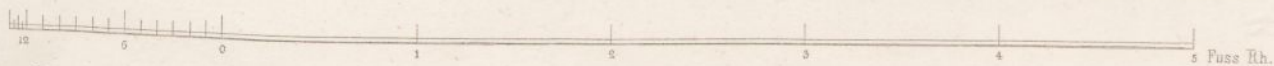

Gez. v. G. Borstell u. F. Koch.

Ernst & Korn in Berlin.

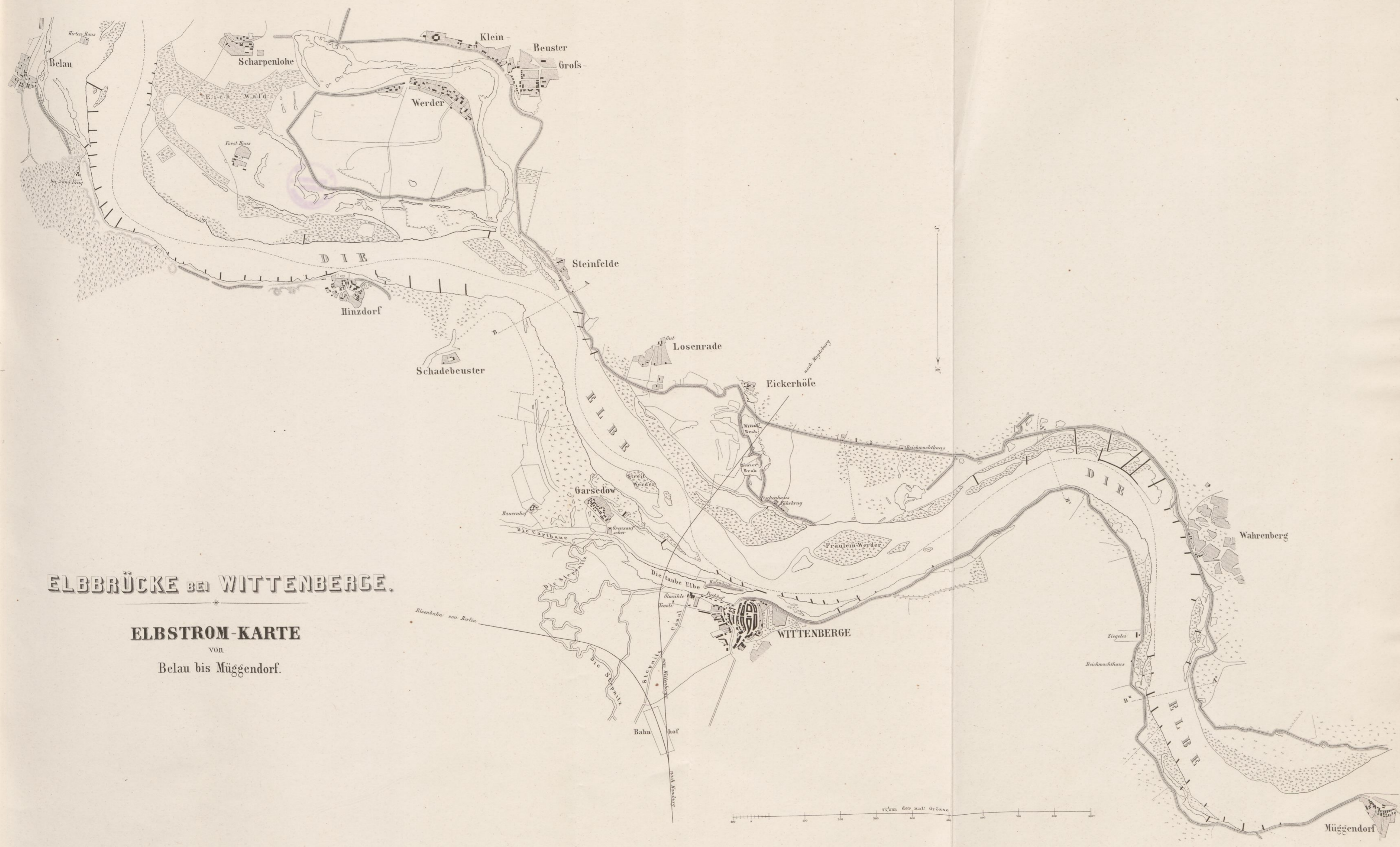

# ELBBRÜCKE bei WITTENBERGE.

**ELBSTRÖM-KARTE**  
von  
Belau bis Müggendorf.



### Elbbrücke bei Wittenberge.

Project nach welchem die Ausführung begonnen wurde.

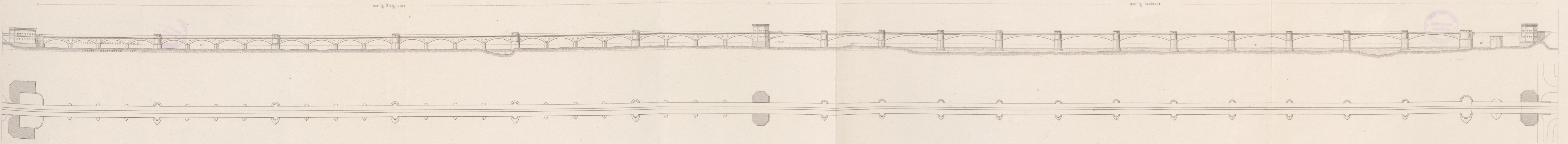

Project nach welchem die Ausführung vollendet wurde.

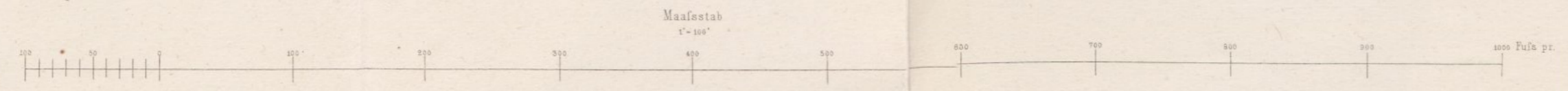
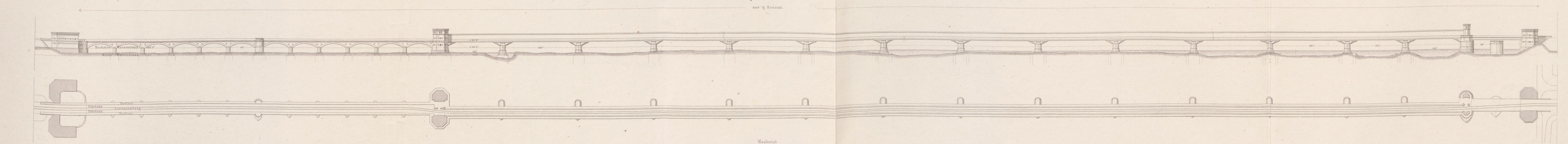

Seiten-Ansicht der Maschine mit dem Krahn.

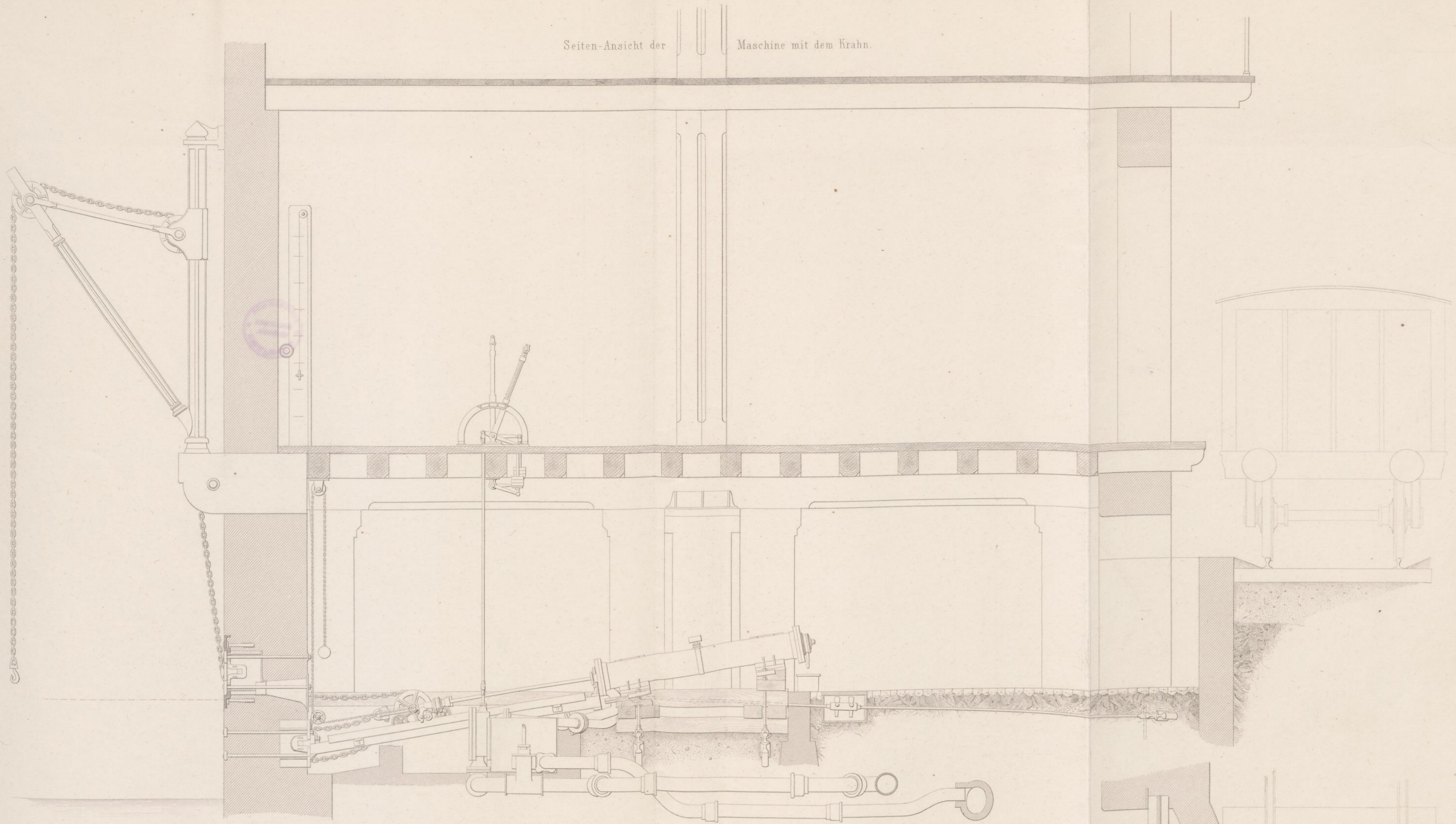

Grundriss.

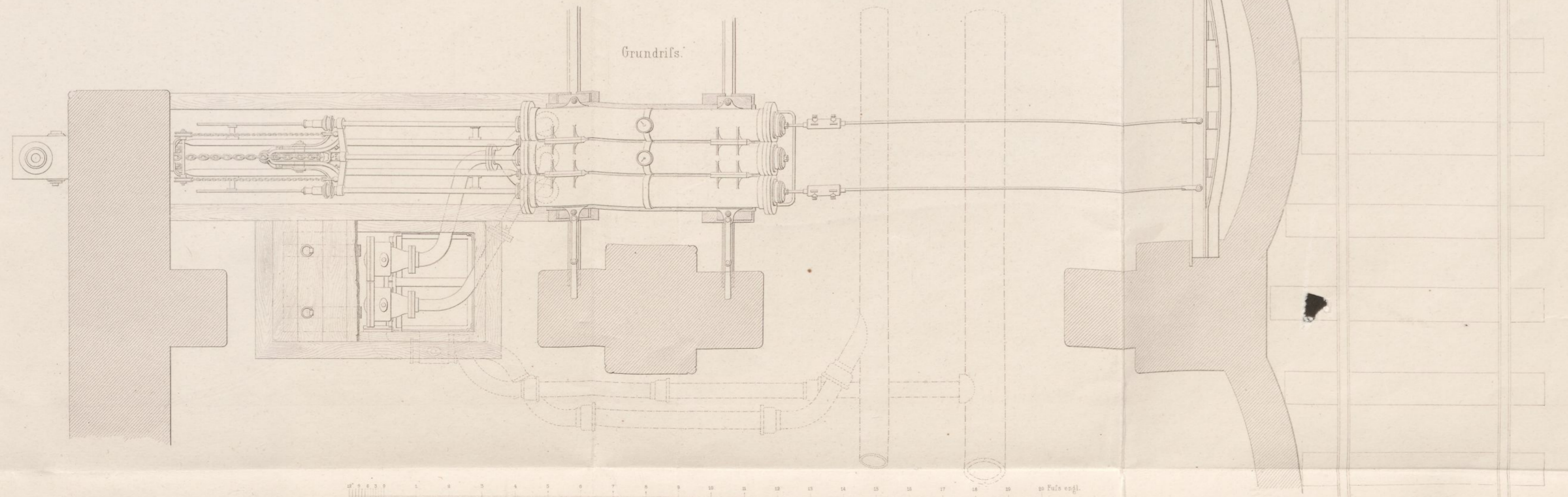



Seiten-Ansicht der hydraulischen Maschine

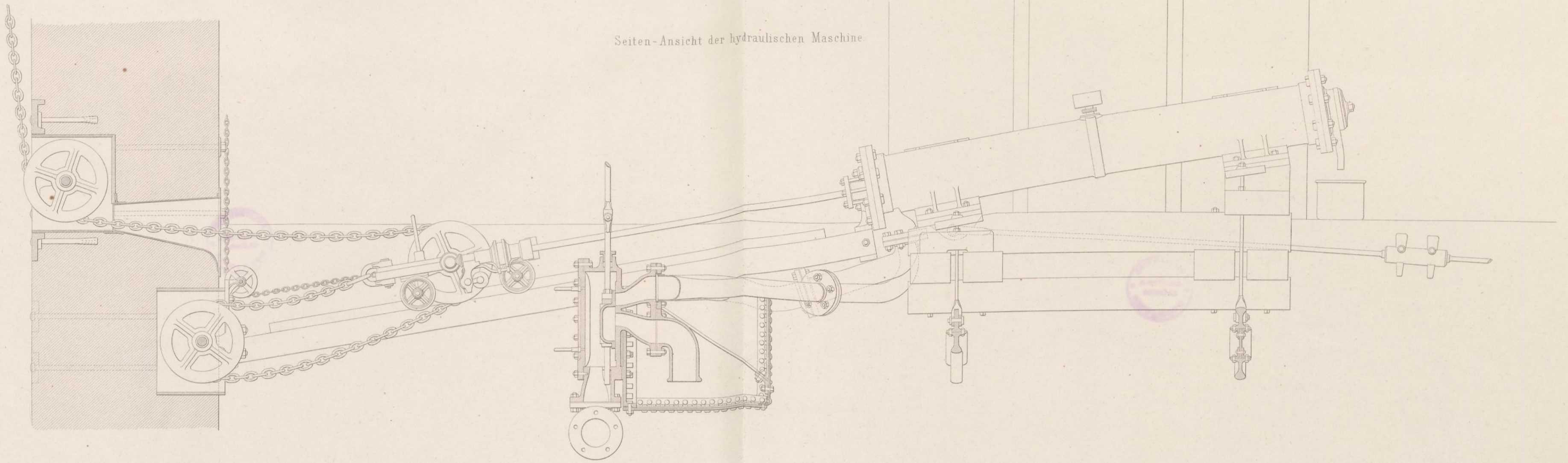

Grundriss.

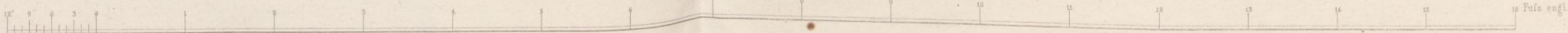
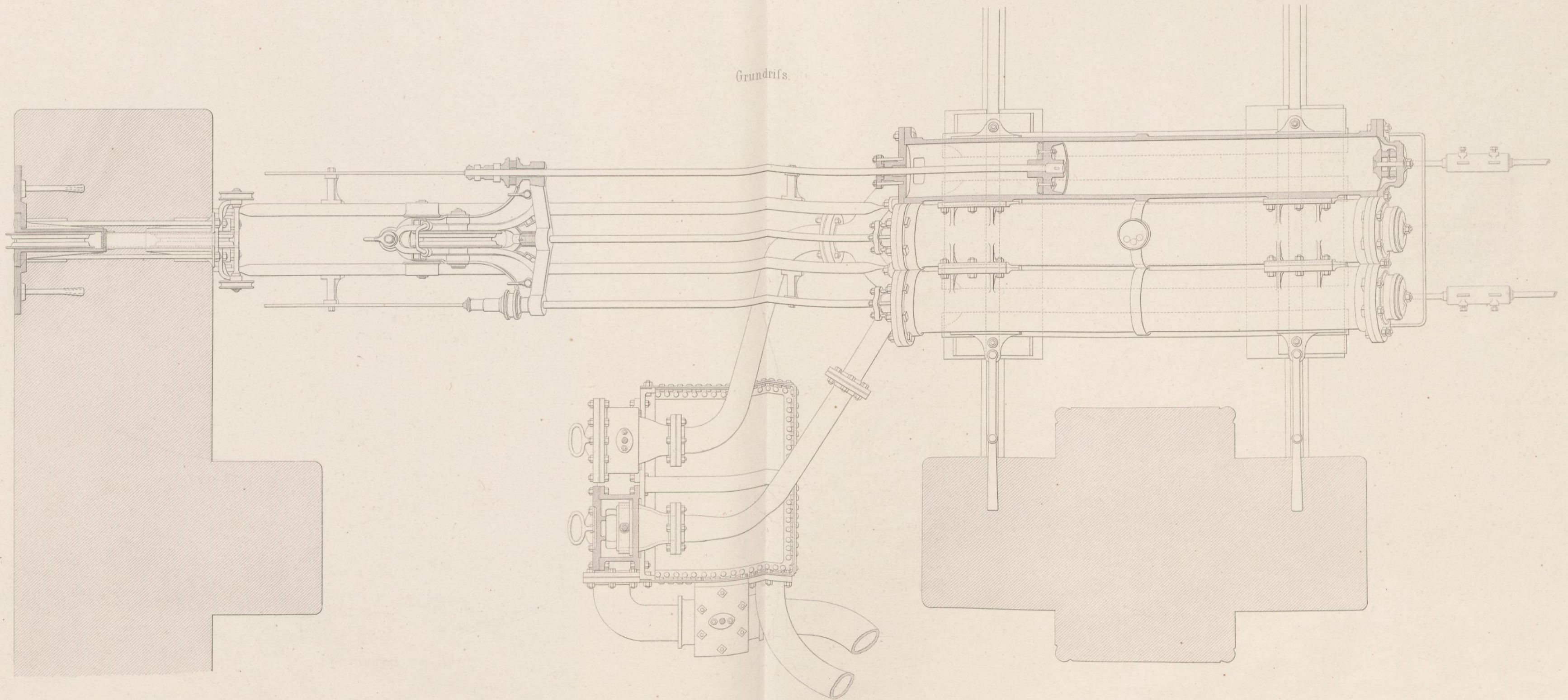

# Hydraulische Windevorrichtung zu Hamburg.

Fig. 1. Vorder-Ansicht der hydraulischen Maschine.

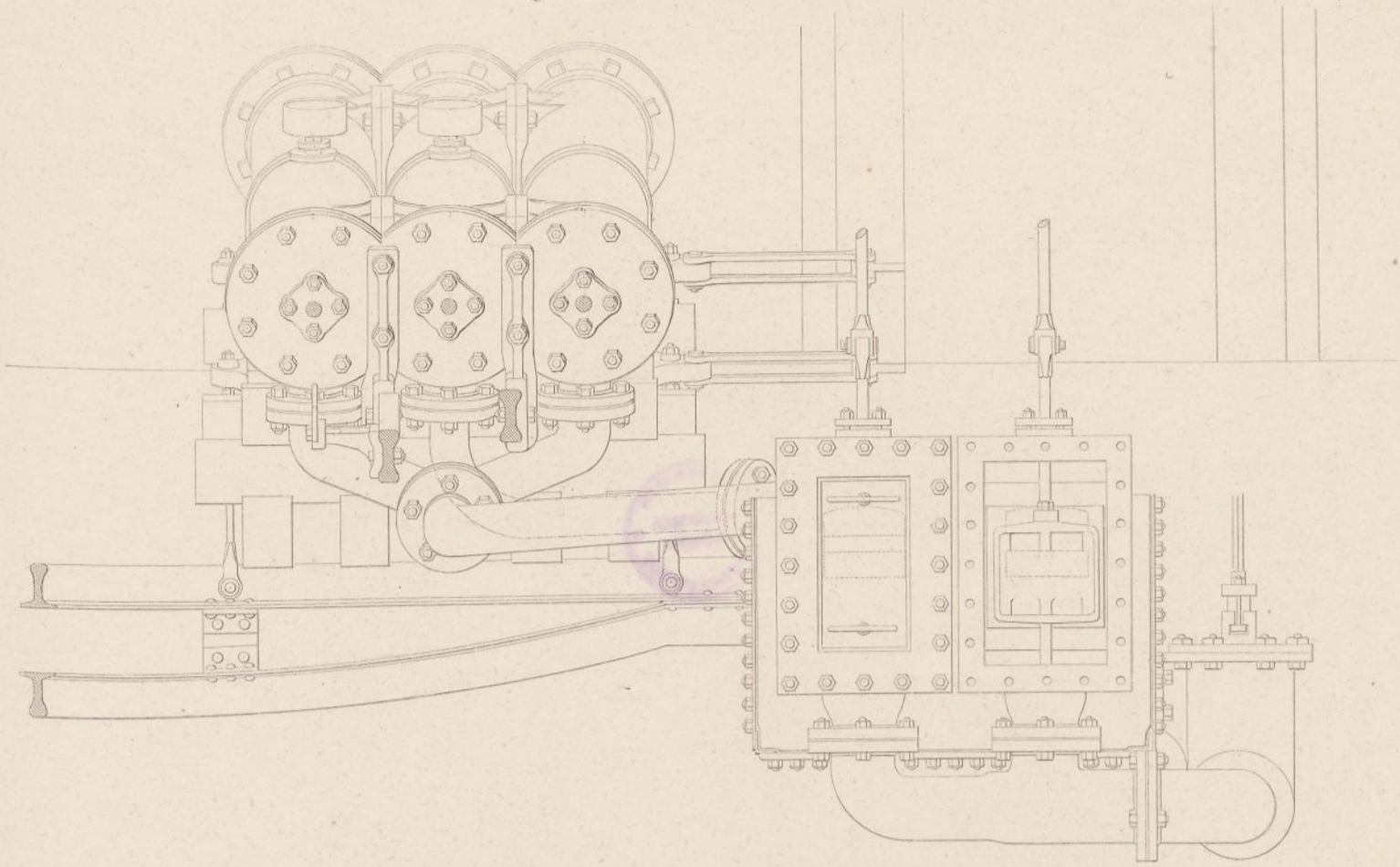

Steuerungs-Vorrichtung.

Abschluss-Ventil.

Fig 2.

Fig 3.

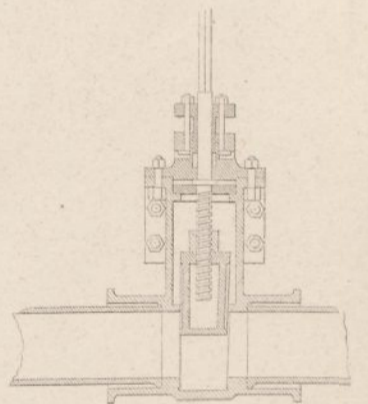
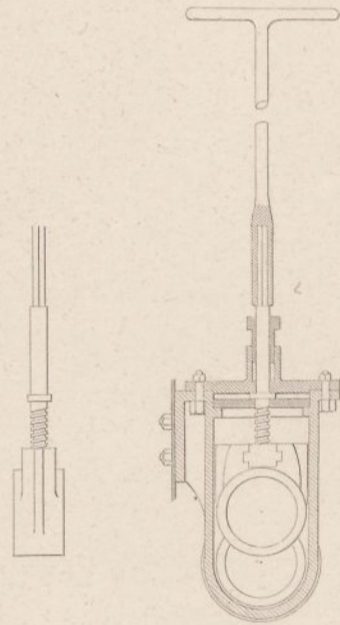
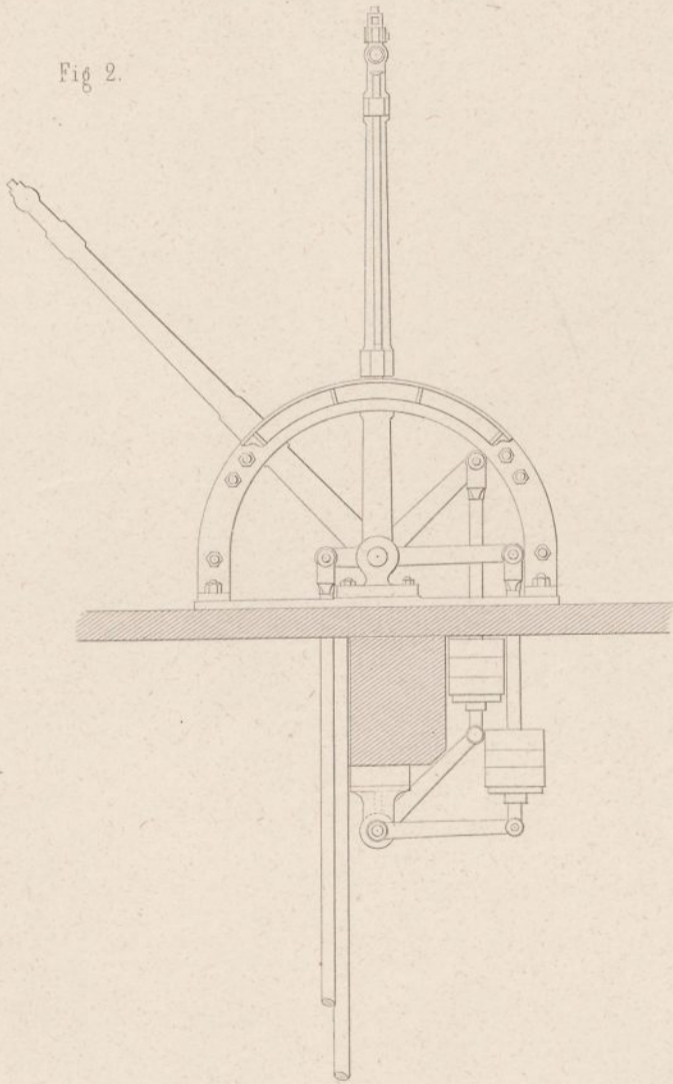
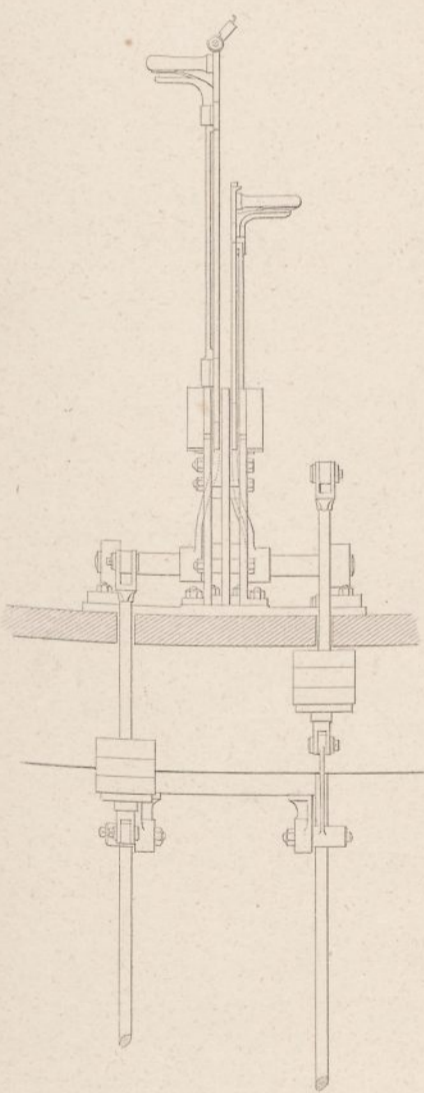

Unterstützungs-Rollen der äusseren Kolbenstangen.

Befestigung der mittleren Kolbenstange an den Kreuzkopf.

Fig. 4.

Fig. 5.

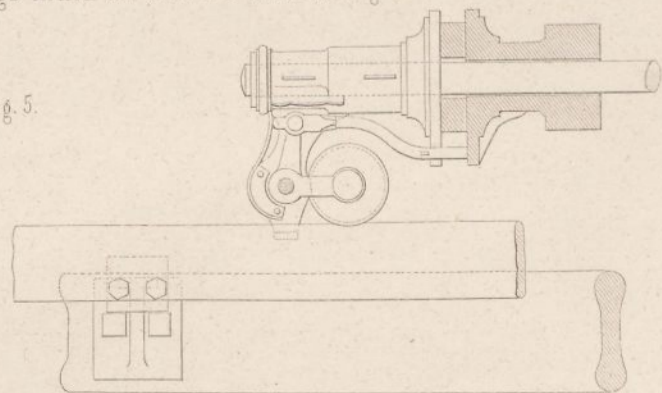
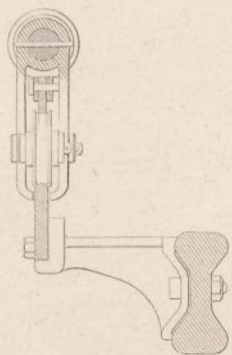
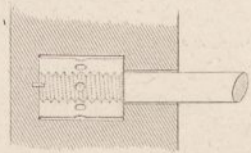



Kloster Chorin.

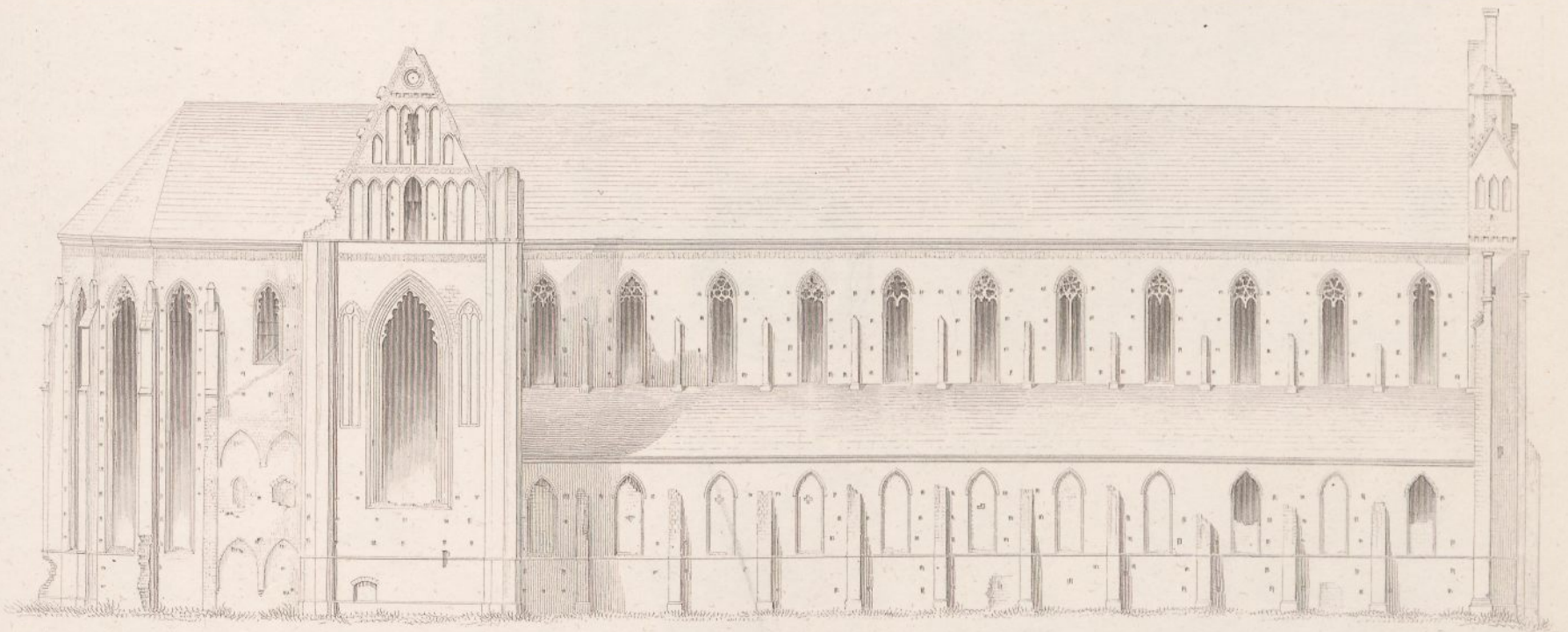
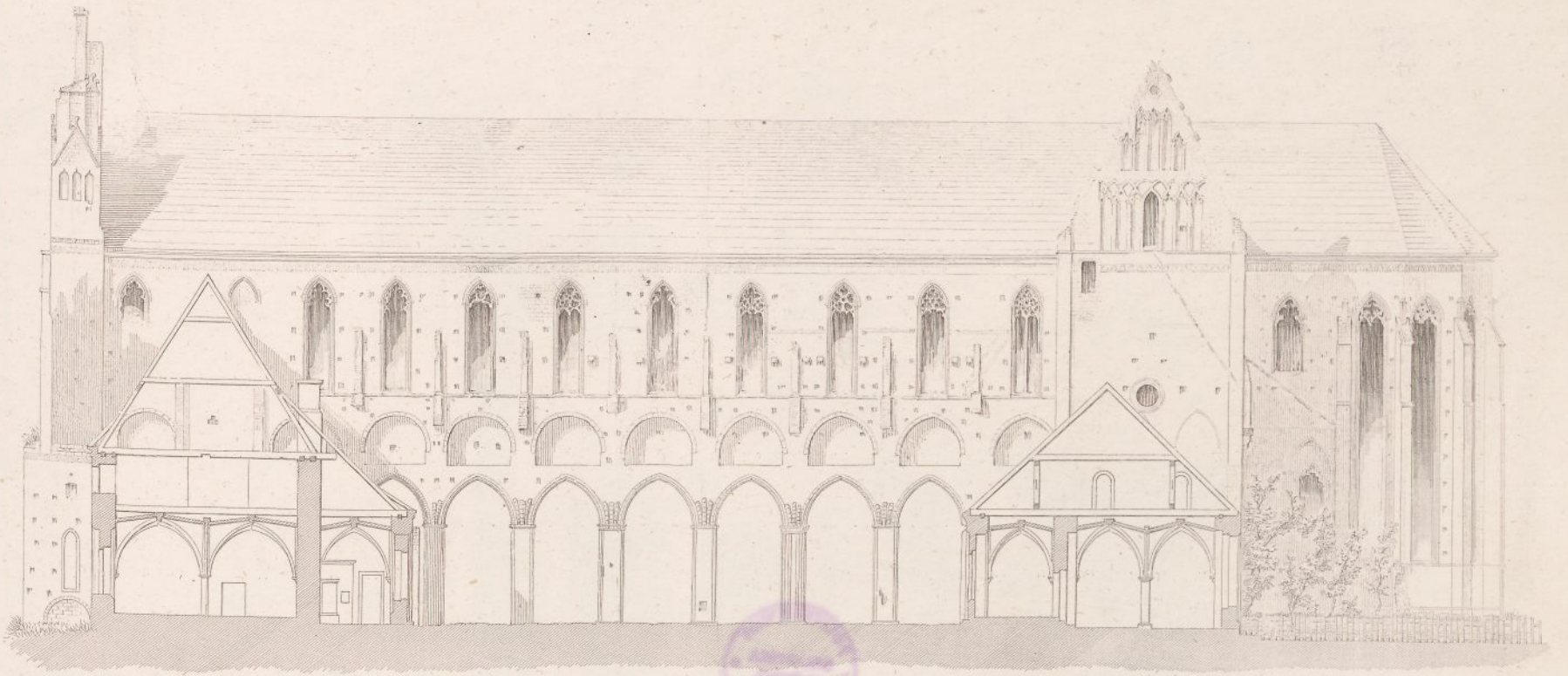

2



3

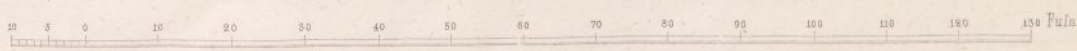

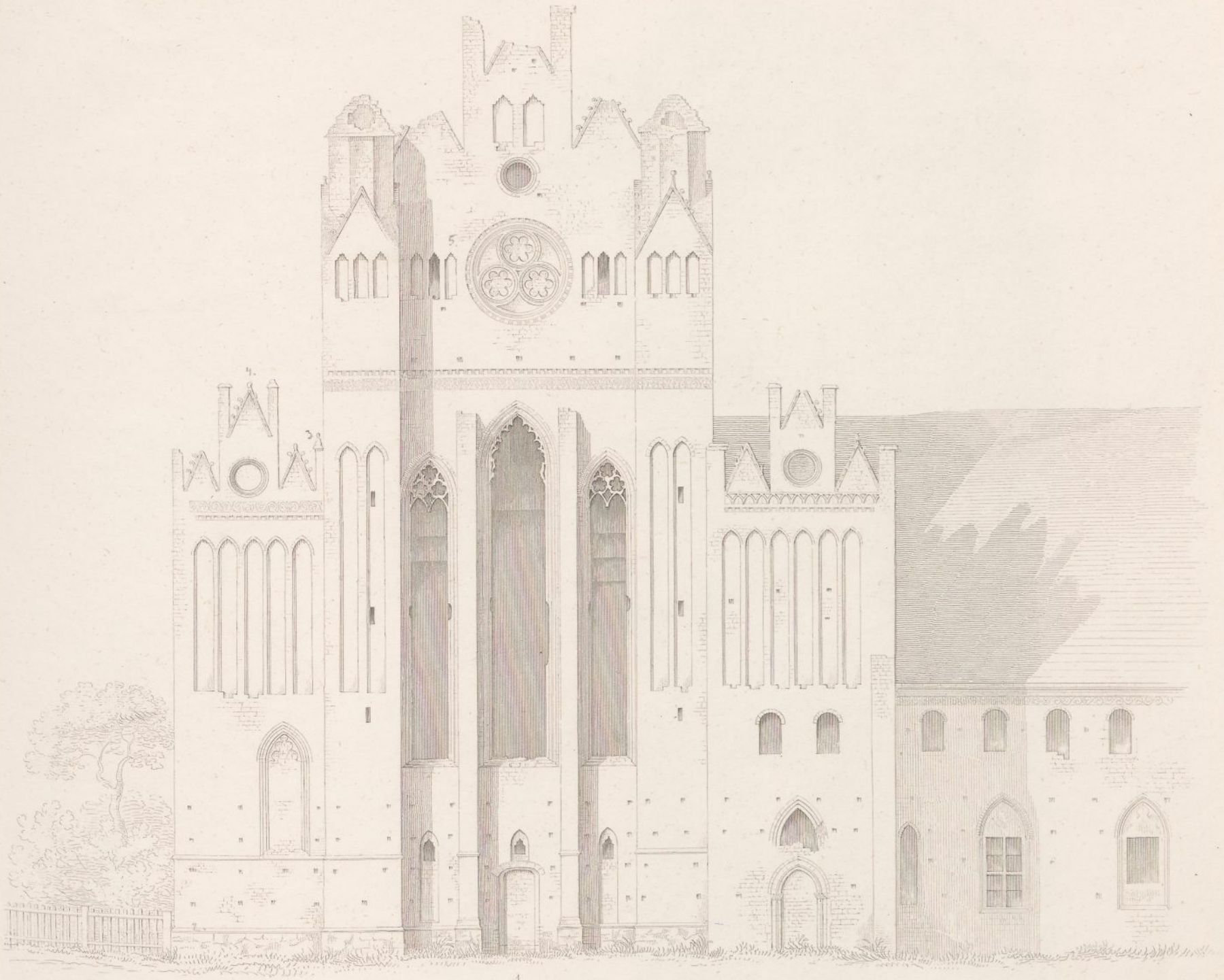

1.

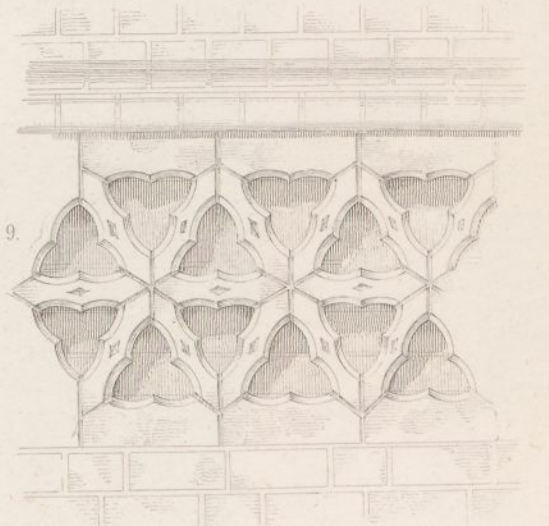

ad 8.

*Walfornis*

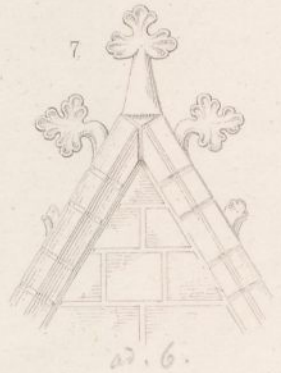
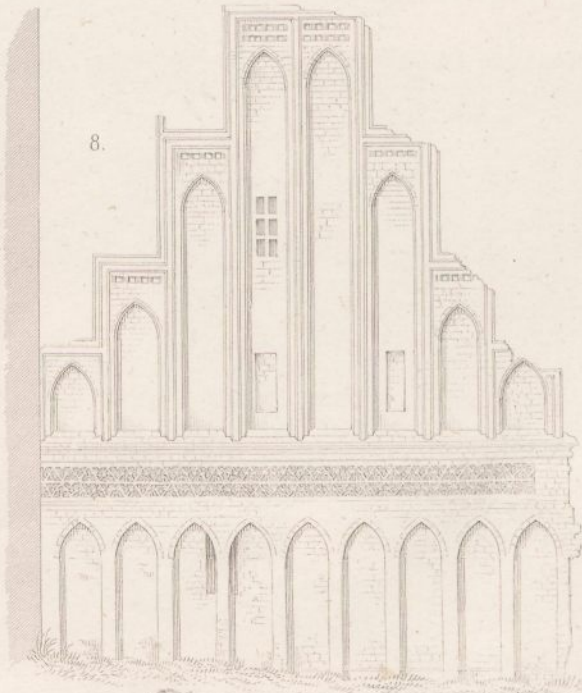
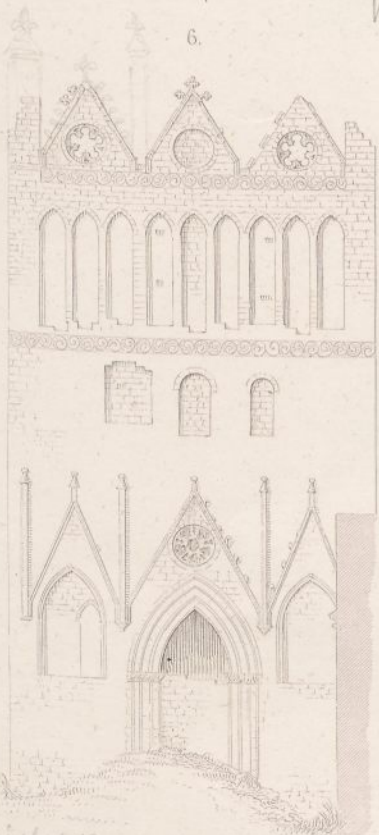

ad 6.

*Westgiebel der westl. Klostergebäude  
d. Pfortenhaus*

*Ostgiebel des Klosterhauses*

10 Fuße Zu Fig 9, 3, 4, 7, 9.

10 Fuße Zu Fig 1, 6, 8.

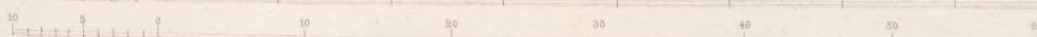



# Kloster Chorin.

Nordseite.

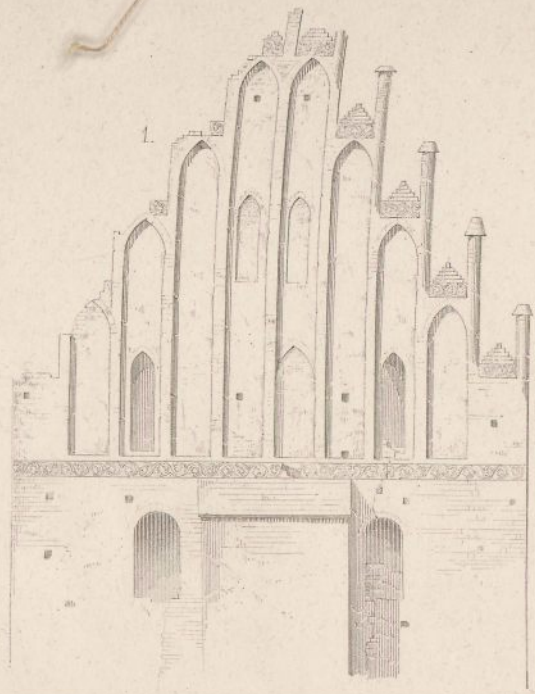

Süd-Gebälde d. West-Klostergeb. (Kloster)

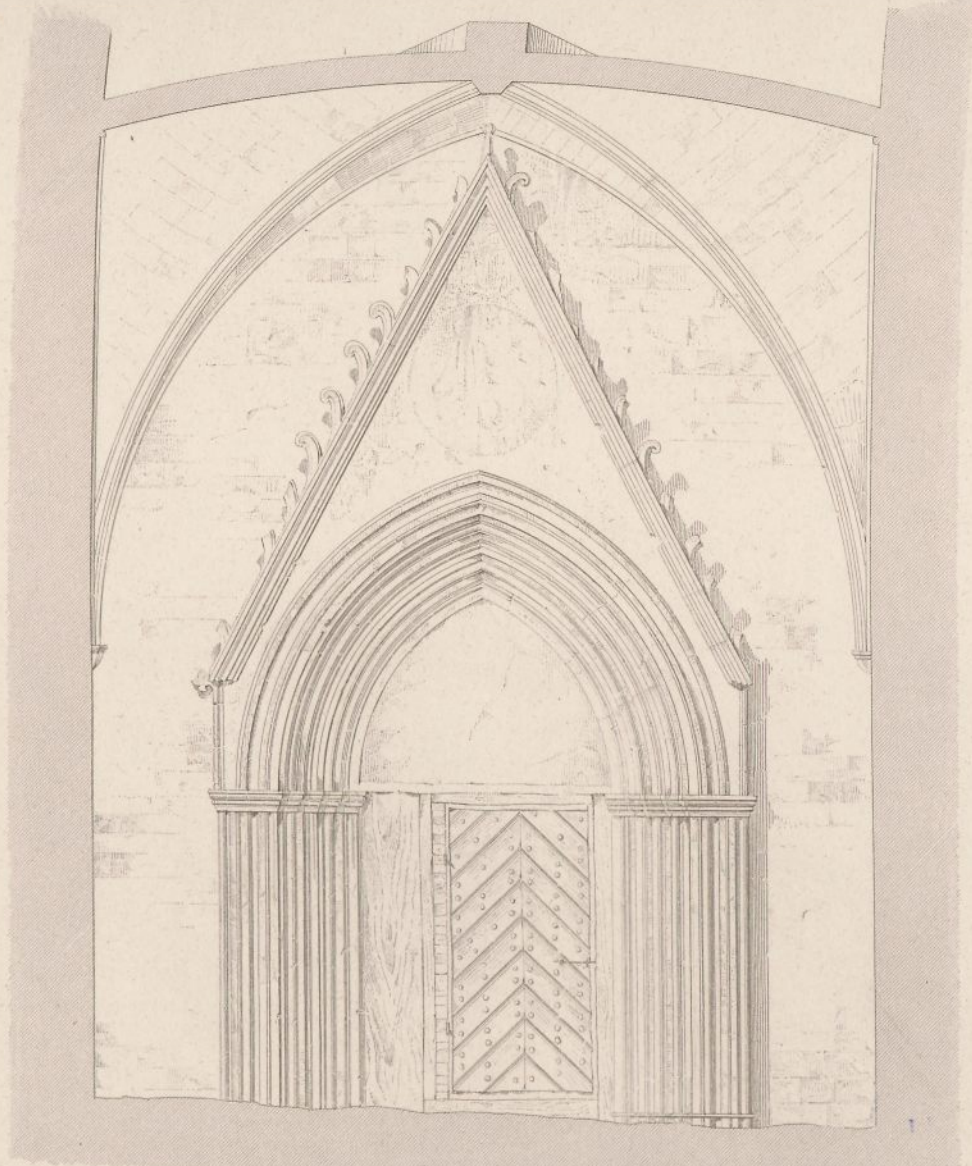

Südt. Portal auf d. Westseite (Südwand) (Probier) (Kloster)

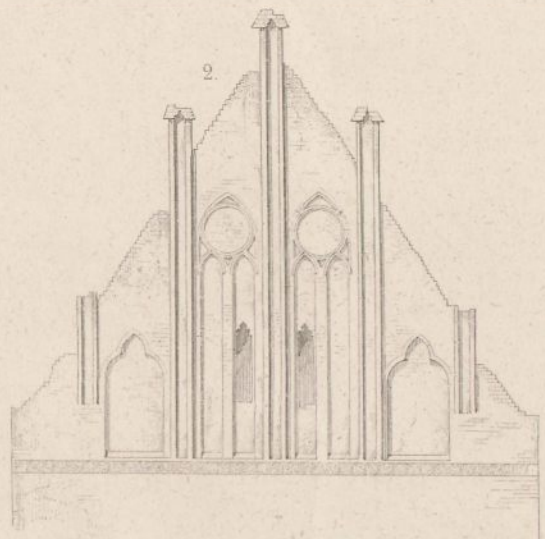

Süd g. 2. West-Klostergeb.

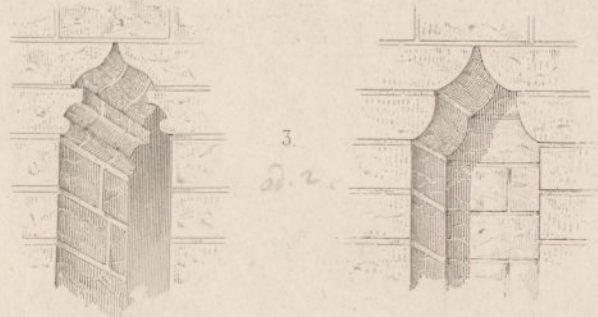

gez. v. Brecht.

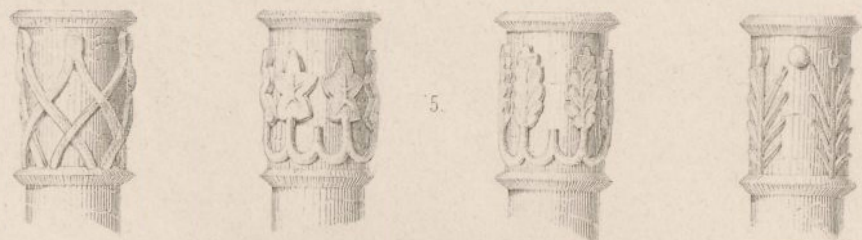

Kapitel v. der Thür d. Ernst & Korn in Berlin auf Klostergeb. & West-Klostergeb. Süd. Seitenhülle & Kreuzgang



Kreuzgang West-Klostergeb.



Südt. Portal auf d. Westseite (Südwand) (Probier) (Kloster)

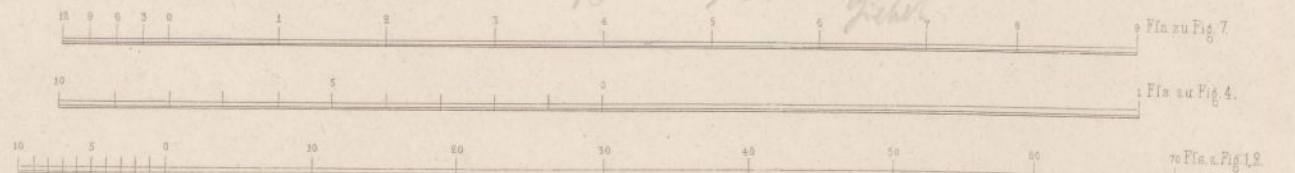
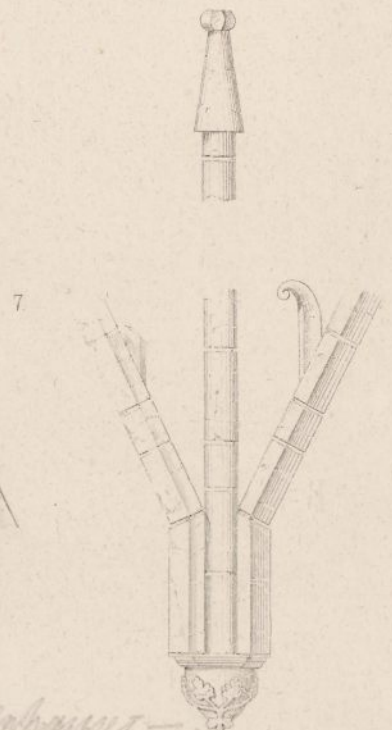

Fl. zu Fig. 7

Fl. zu Fig. 4

Fl. zu Fig. 12

gez. v. L. Ritter

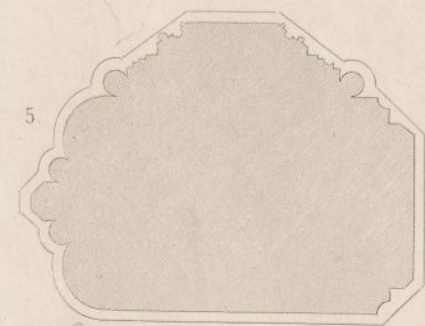
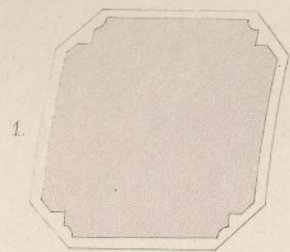

Kleinere Pfeiler

des v. D. recht.



7 ad. 1.

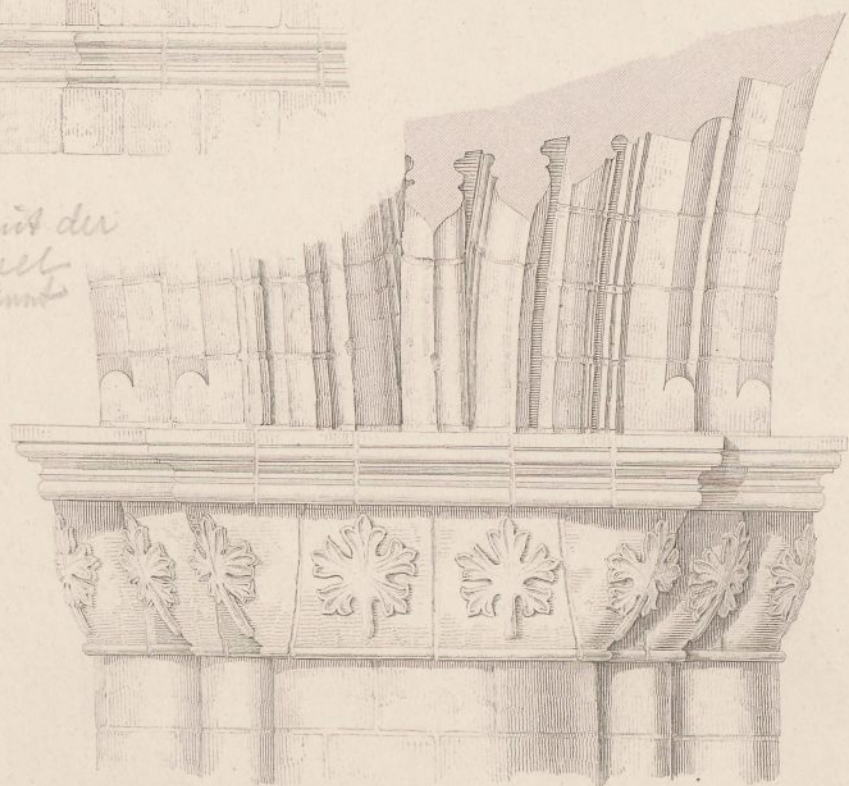
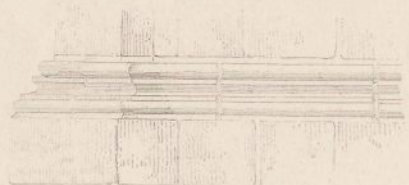

von S Schiff nach N 8 ad. 2.

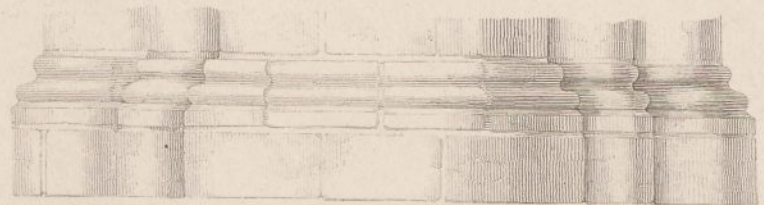

9 ad. 2.



v. Mittelschiffe aus

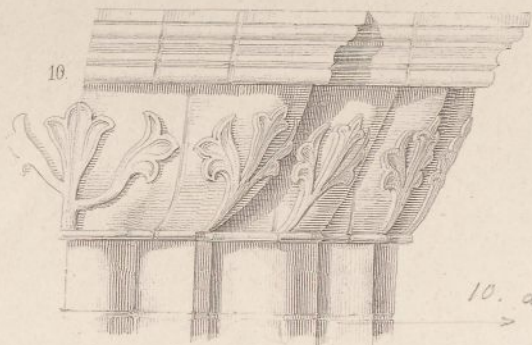

10. ad. 4.

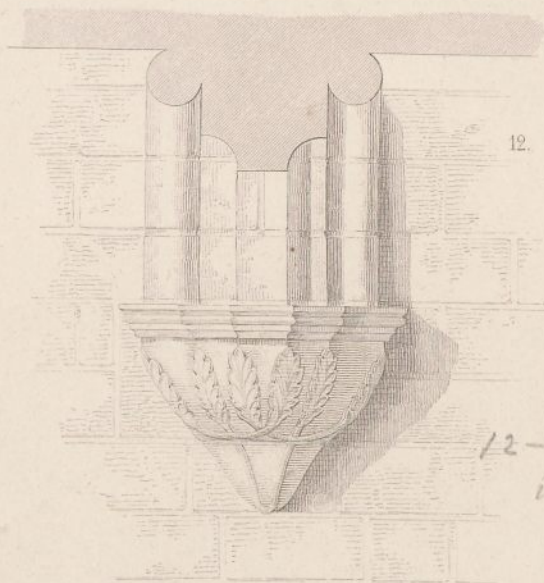

Mittel-schiff

12-17 Kuppeln i. M. Schiffe



im Mittel-schiff



Ernst & Korn in Berlin.

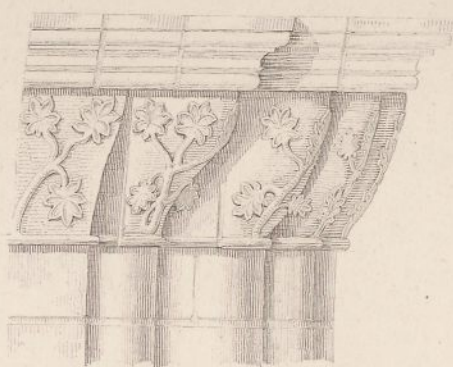

11. ad. 3.



15.



16.

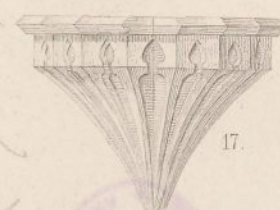

17.



18.

Kapitelle

zu den Schiff-Diagonalen



22.



aus den Seiten-schiffen



25.



gest. v. Kähler.

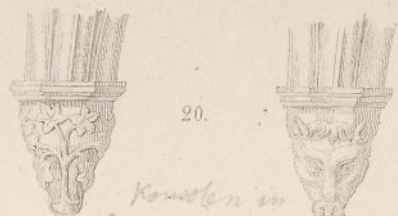

20.

Kuppeln in den Kreuzgängen

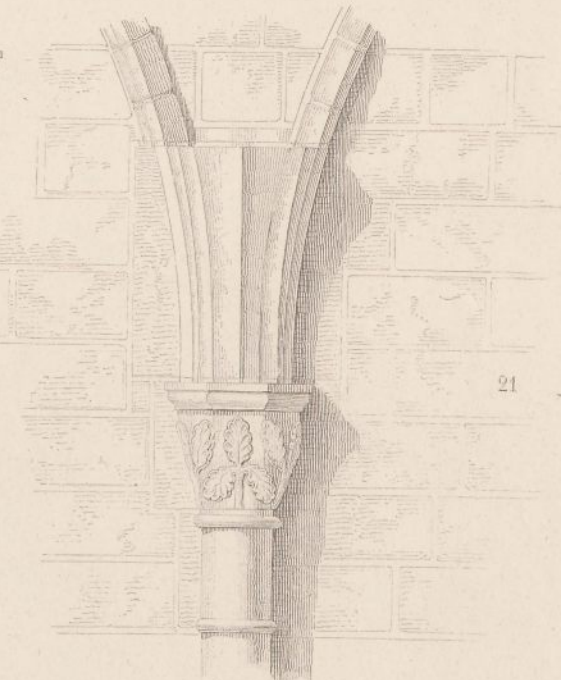

21.

Seiten-schiff





1-6 Fenster aus dem Mittelschiff.

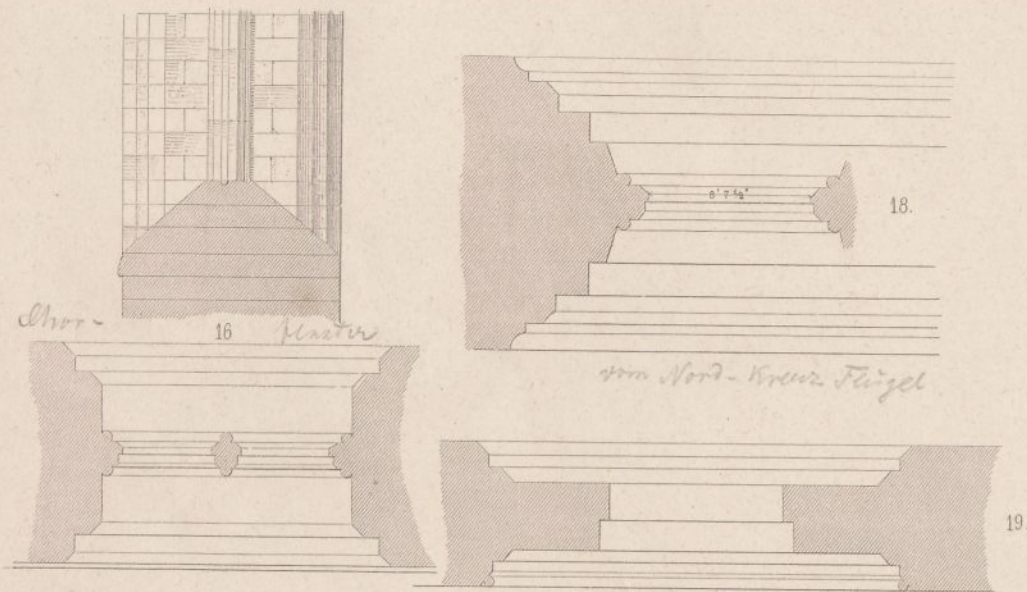

Chor-Fenster

von Nord-Kreuz-Faßgel

aus S-Kreuzgange

Seite S. Süd-Faßgel im Ch.

Ausschnitt d. Stützhauwer

Thürans.

Thür v. S. Seitensch. nach S. Ost-Kreuzgangflügel.



Fenster im Chor (andere Stab- + Maßwerks Profil als im Schiff)

v. d. Westseite d. Westsch.

v. d. Westfront der Kirche - Maßwerk nicht von d.

Mittelschiff.

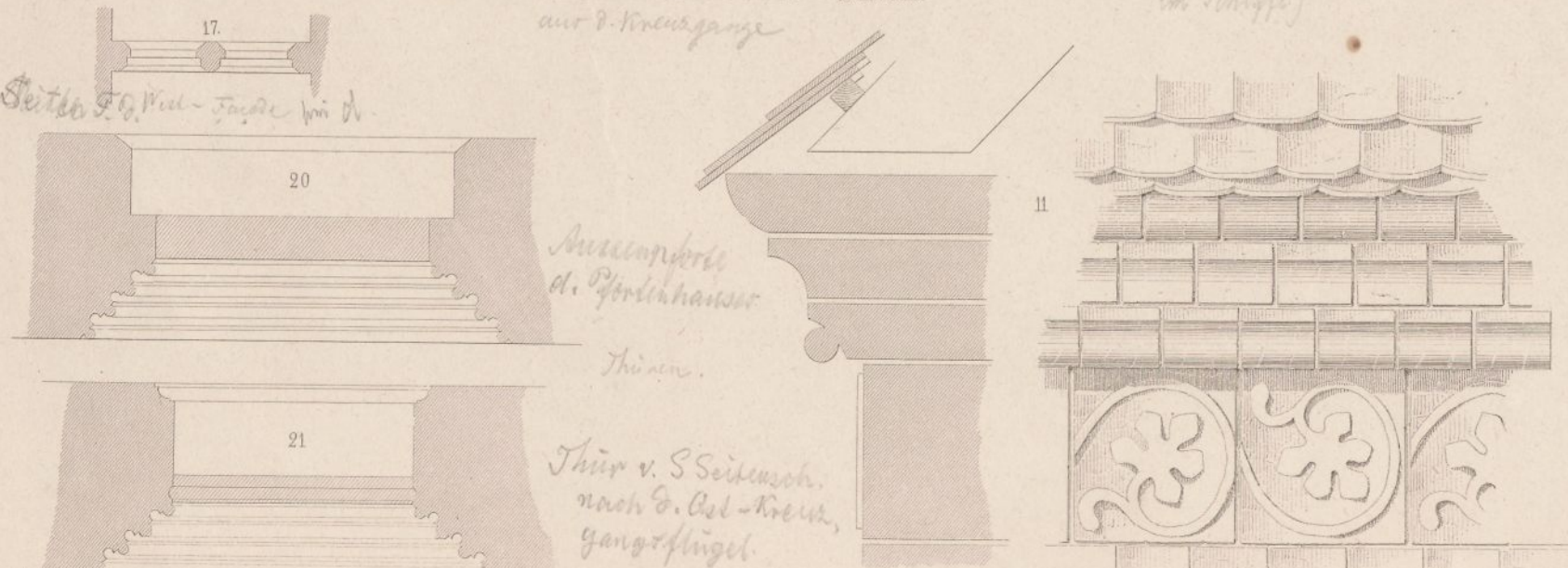

Hauptges. d. Mittel-Sch. F. u. G. F. u. G. F. u. G.

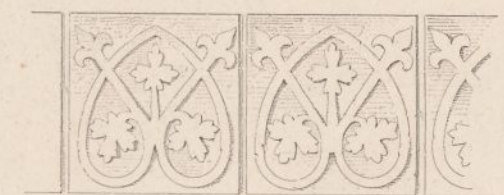
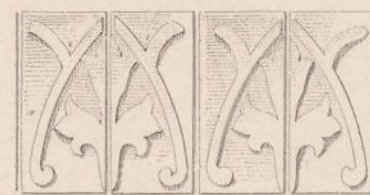

Friesen, wo? (öfters vorkommend?)

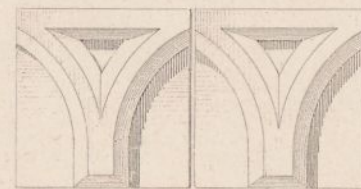

Brandhaus Kische



16 Fia. zu Fig. 16-21.

17 Fia. zu Fig. 1-15.

der Gräflich von Ziethen'schen Familie zu Ramstedt.



Perspectivische Ansicht.



Vorderansicht.

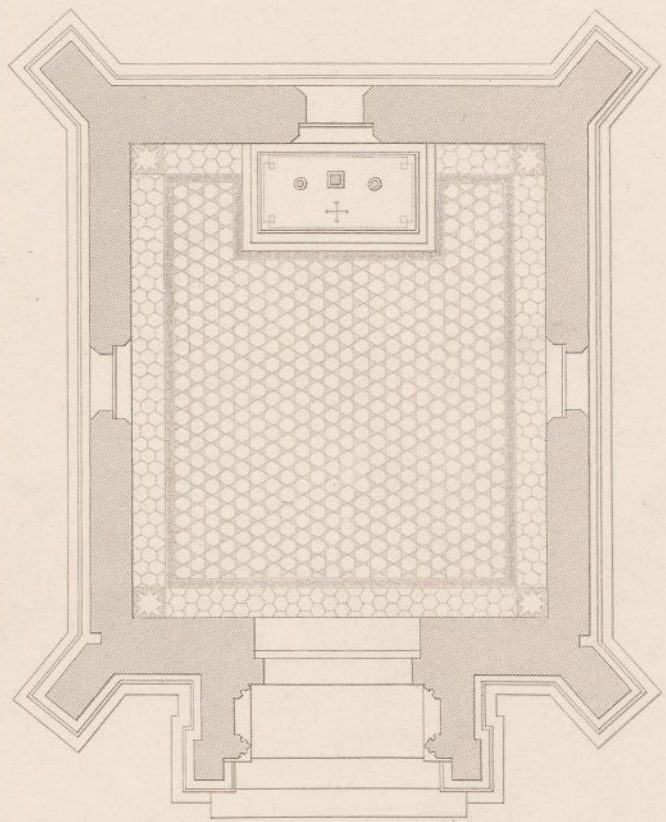

Grundrifs.

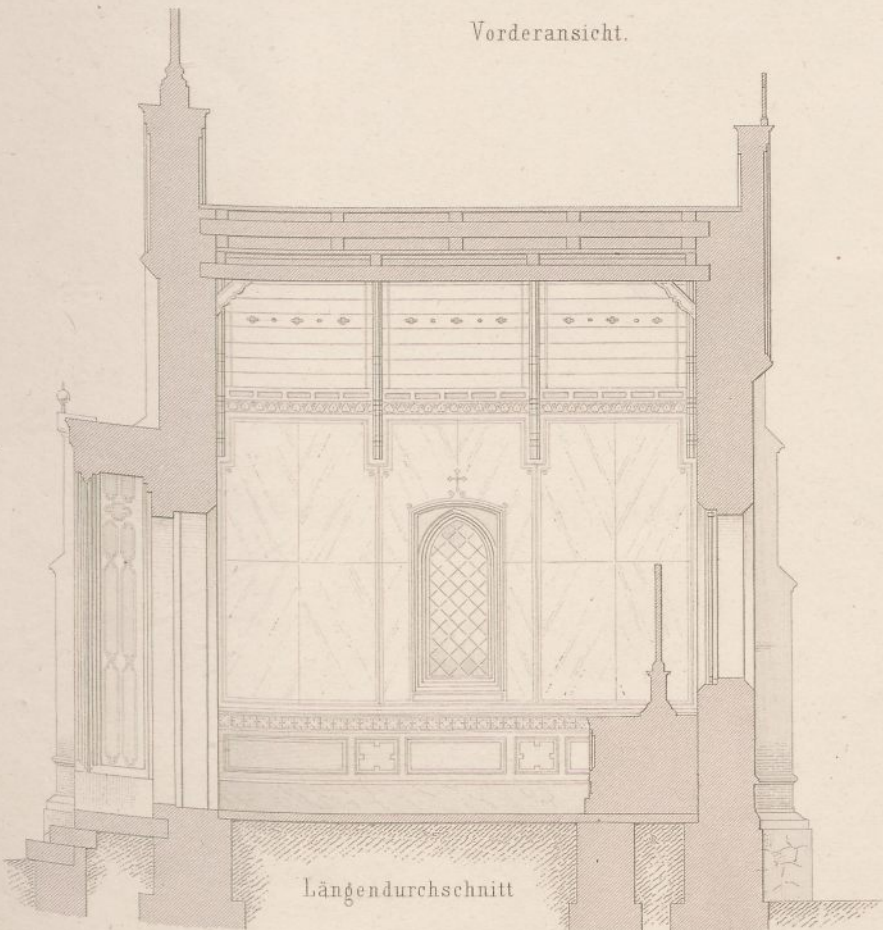

Längendurchschnitt

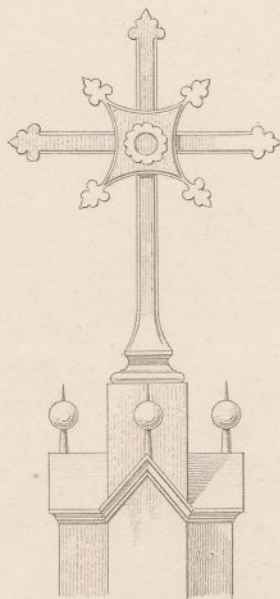

Detail des Kreuzes.

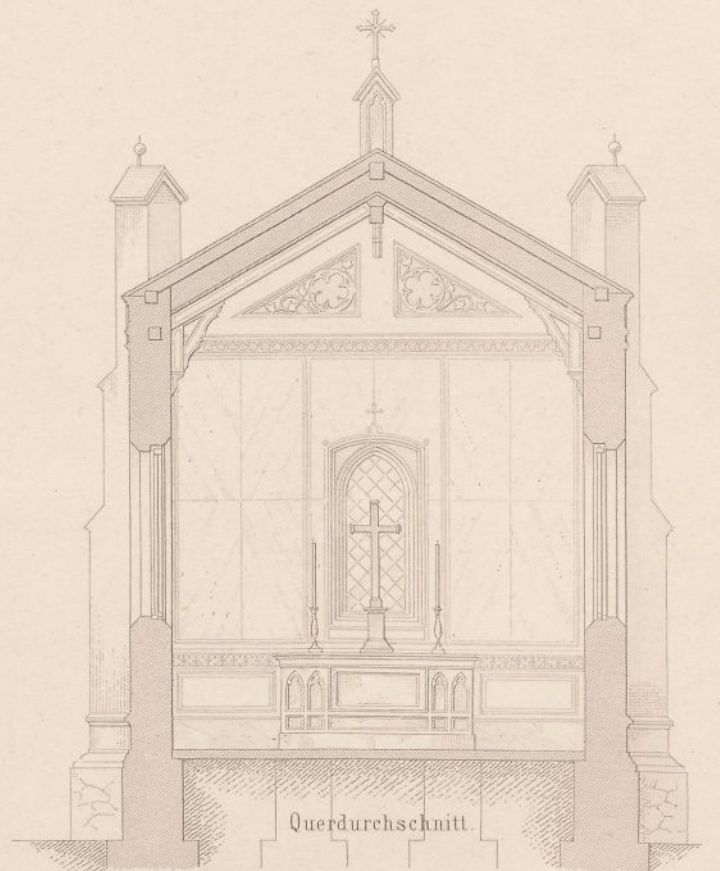

Querdurchschnitt

Irren-Anstalt zu Schwetz.

Situations-Plan

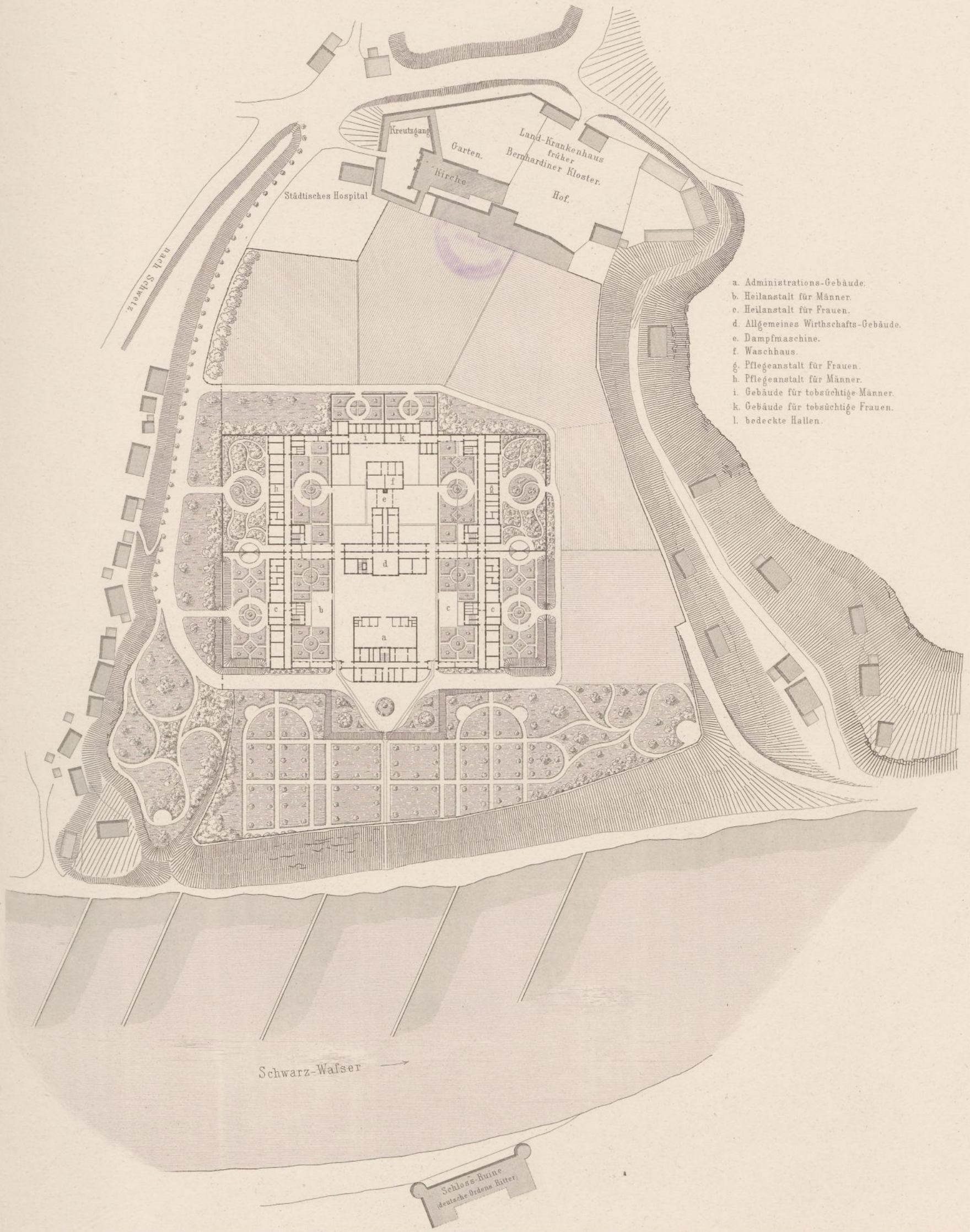

- a. Administrations-Gebäude.
- b. Heilanstalt für Männer.
- c. Heilanstalt für Frauen.
- d. Allgemeines Wirthschafts-Gebäude.
- e. Dampfmaschine.
- f. Waschhaus.
- g. Pflegeanstalt für Frauen.
- h. Pflegeanstalt für Männer.
- i. Gebäude für tobsüchtige Männer.
- k. Gebäude für tobsüchtige Frauen.
- l. bedeckte Hallen.

10 5 0 10 20 30 40 50 Rth.

# Irren-Anstalt zu Schwetz.

## Administrations und Directorialgebäude

Vordere Ansicht.

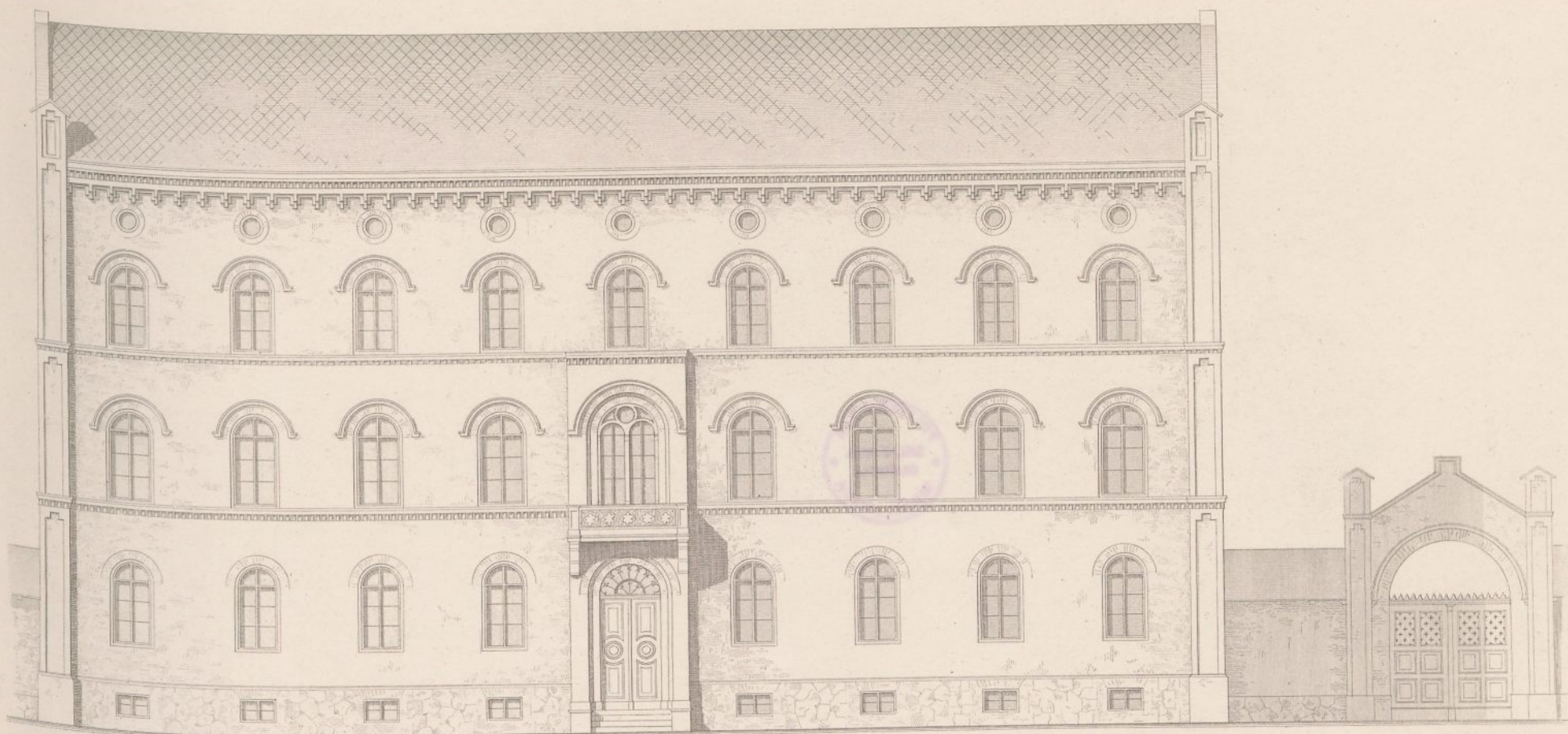

Durchschnitt nach AB.

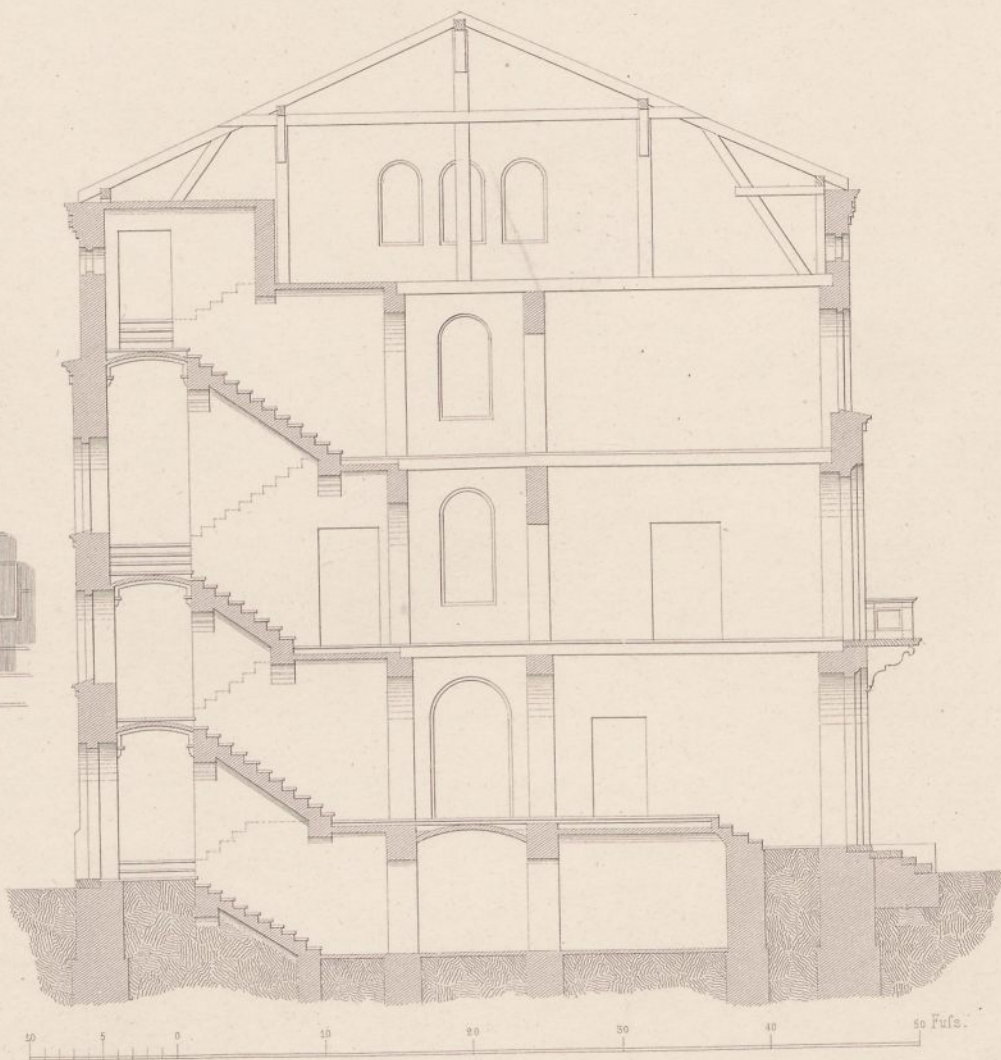

Haupt-Gesims.

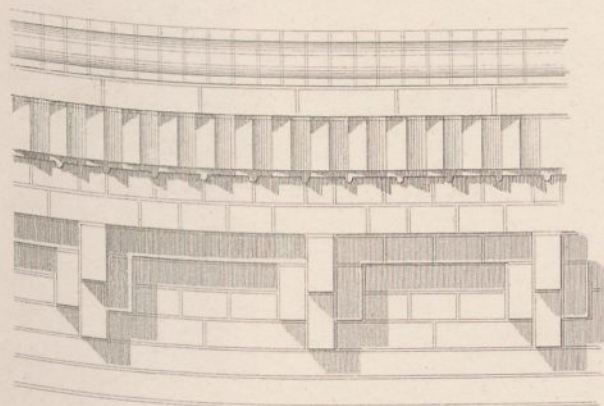

Profil des Hauptgesimses.

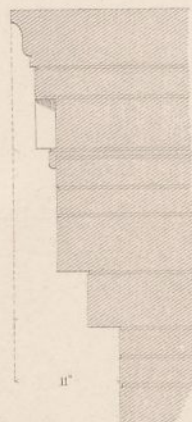

Zoll 1 2 3 4 5 6 Fufs.

10 20 30 40 50 60 Fufs.

Grundriss des Erdgeschosses.

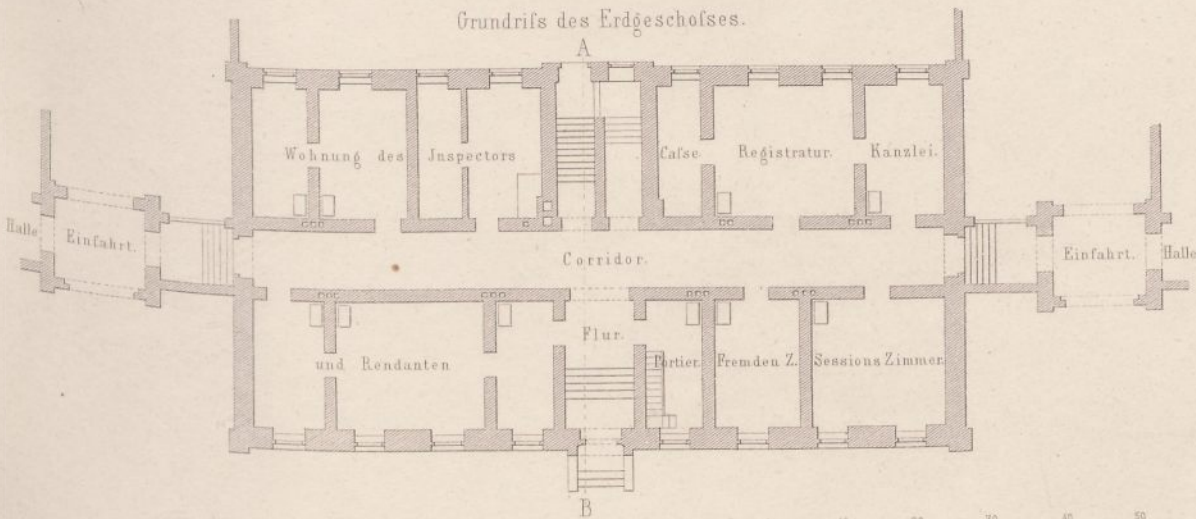

Grundriss des II. Stocks.

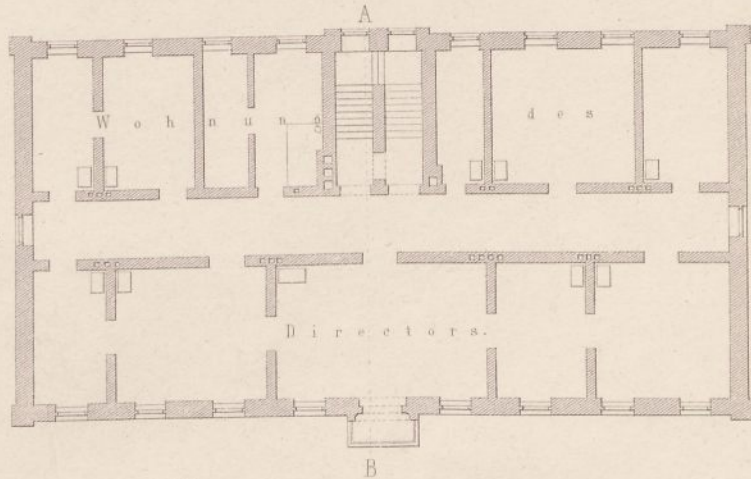

Heil-Anstalt für Männer.

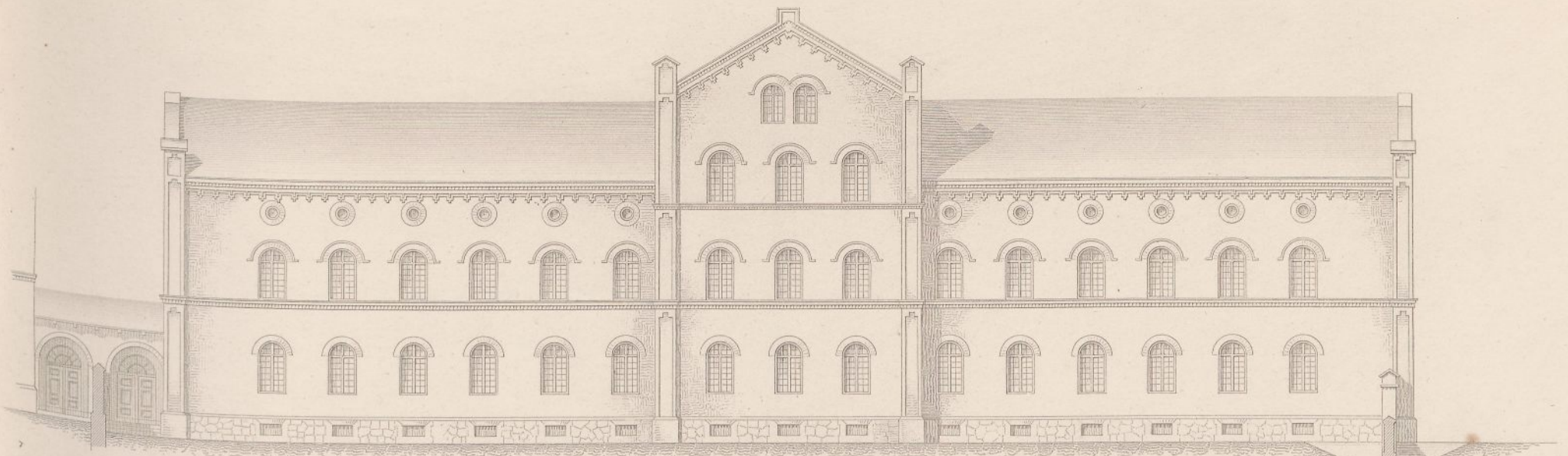

Vorderansicht.

Grundriss des III<sup>ten</sup> Stocks.

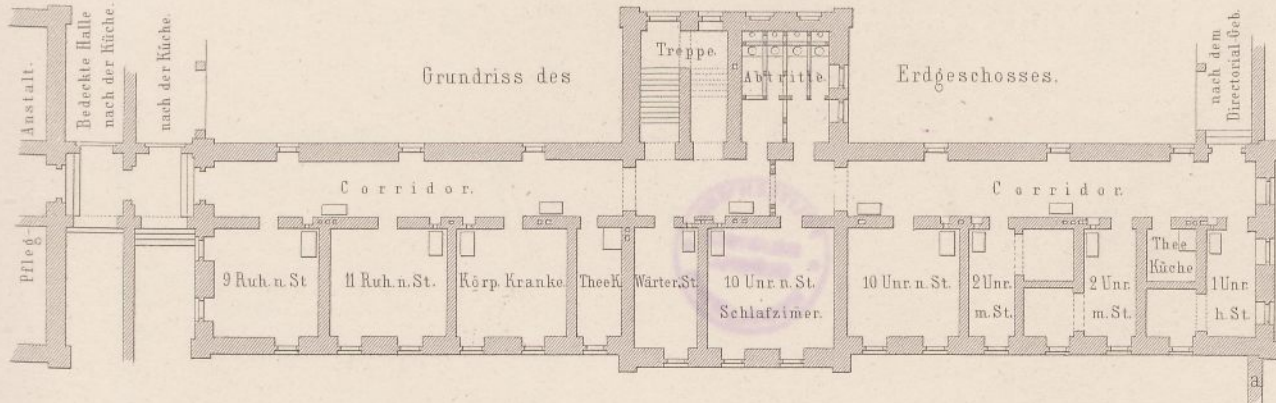
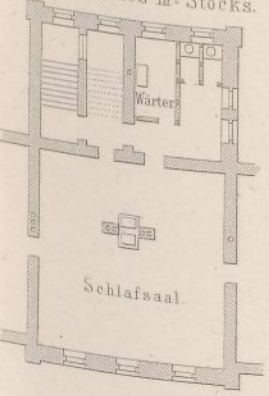

Mauerbekrönung bei a.

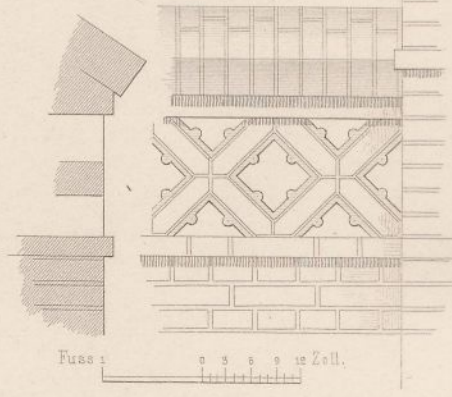

Pfleg-Anstalt für Männer.

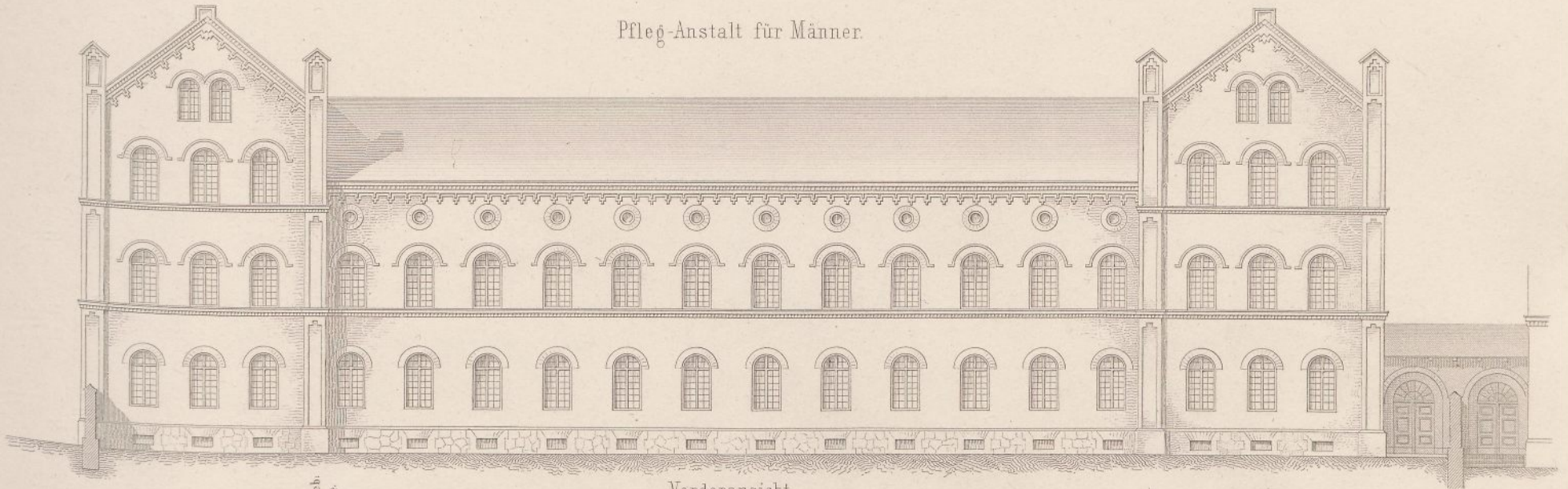

Vorderansicht.

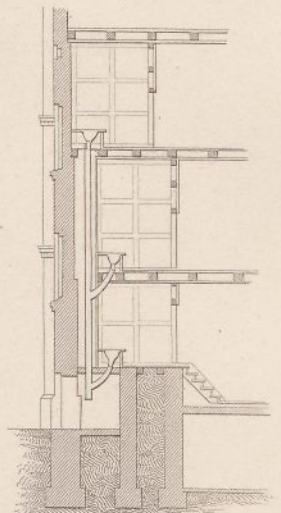
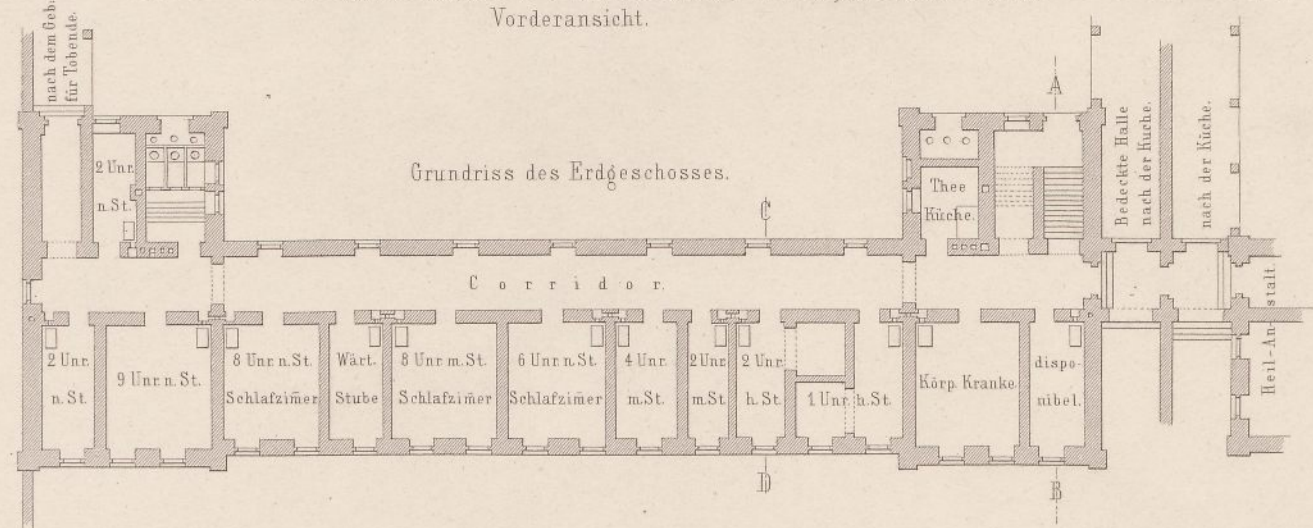
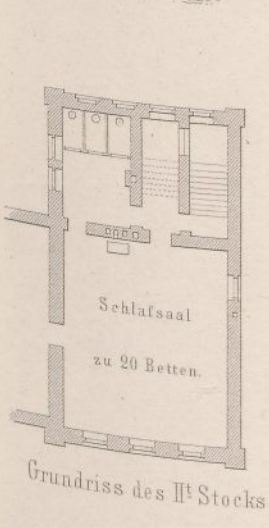

Durchschnitt der Abtritte.

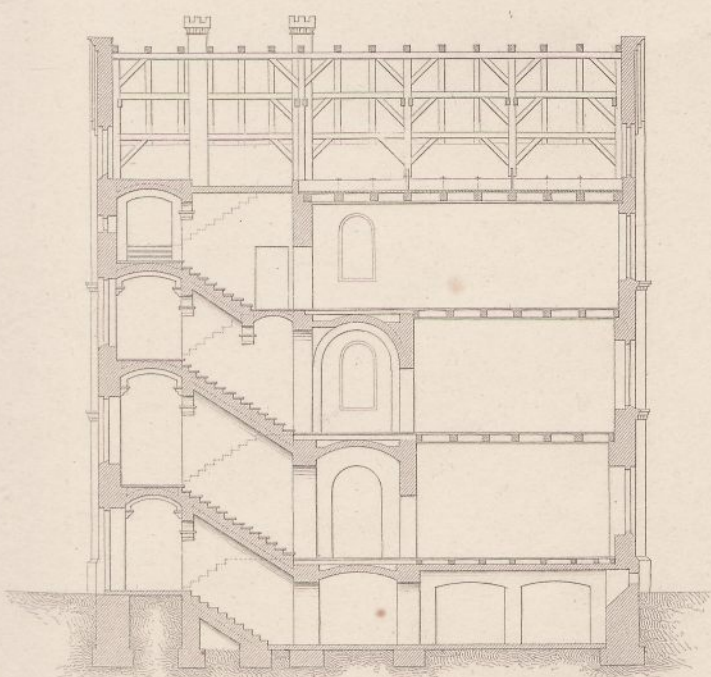

Durchschnitt nach AB.

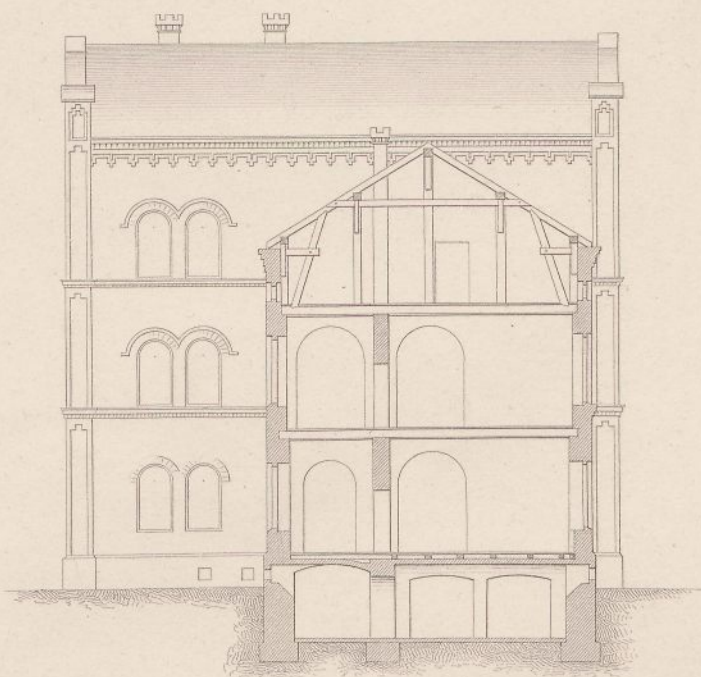

Durchschnitt nach CD.



Brauerei-Gebäude

von E. Wagner bei Berlin.

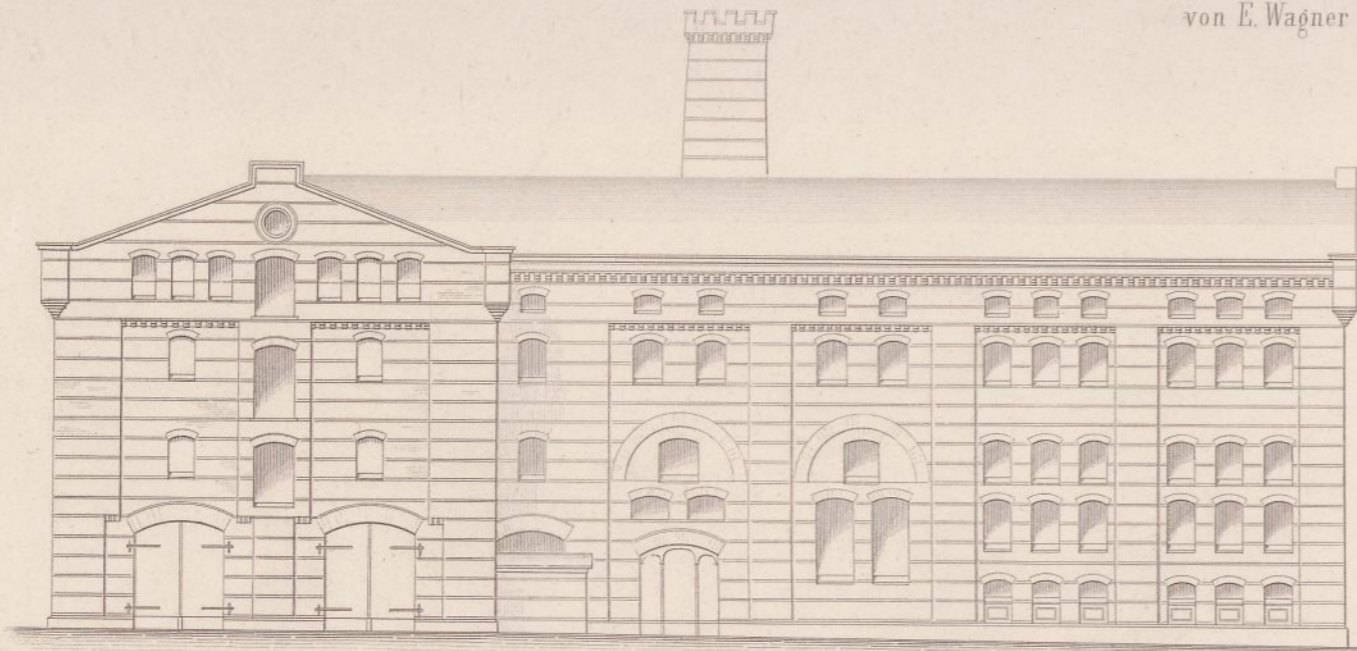

Ansicht nach dem Hofe.



Ansicht nach der Strasse.

Grundriss zur ebenen Erde

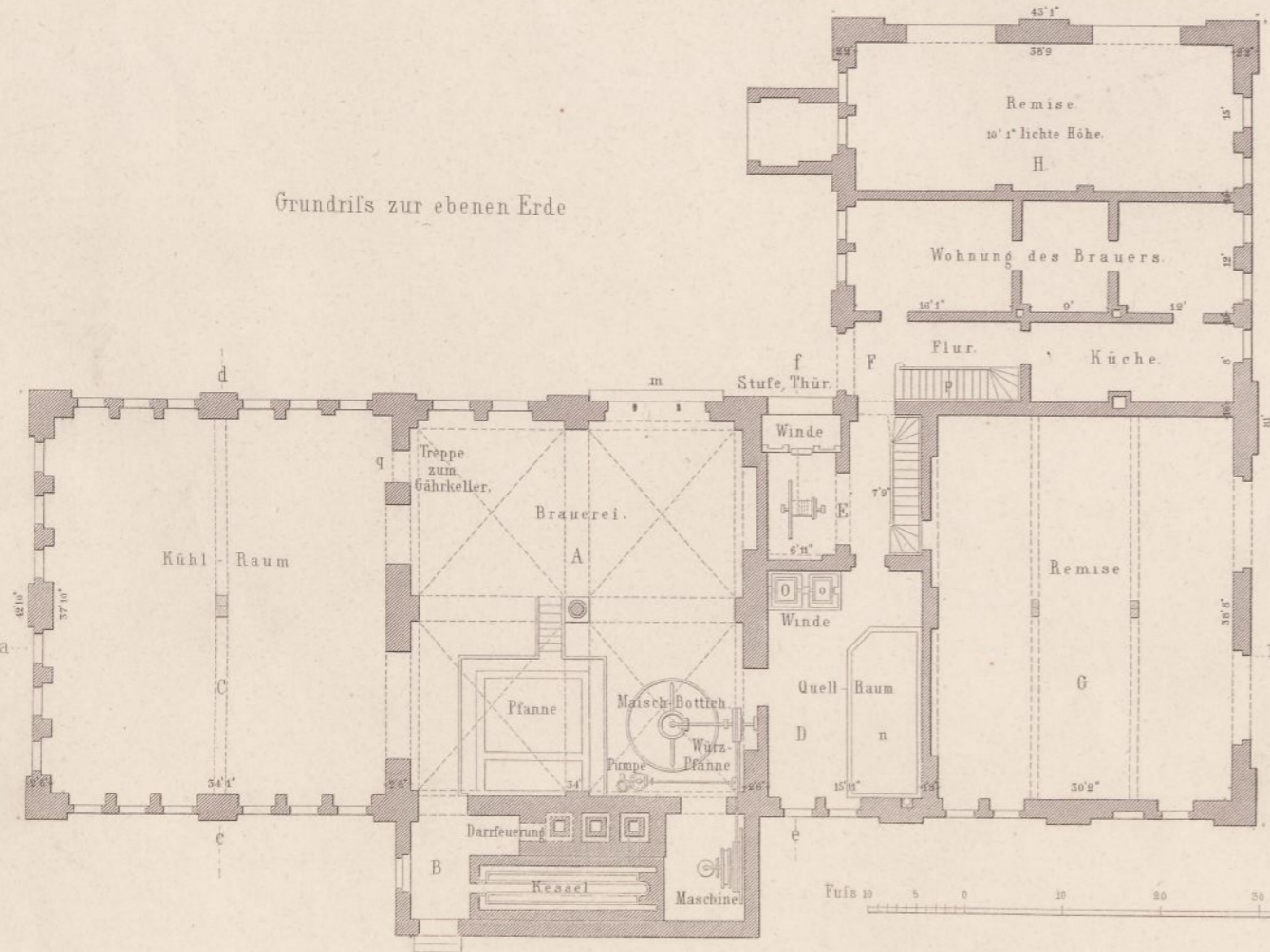

Grundriss der oberen Etage

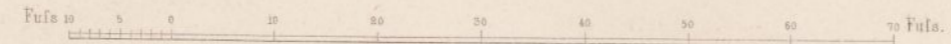
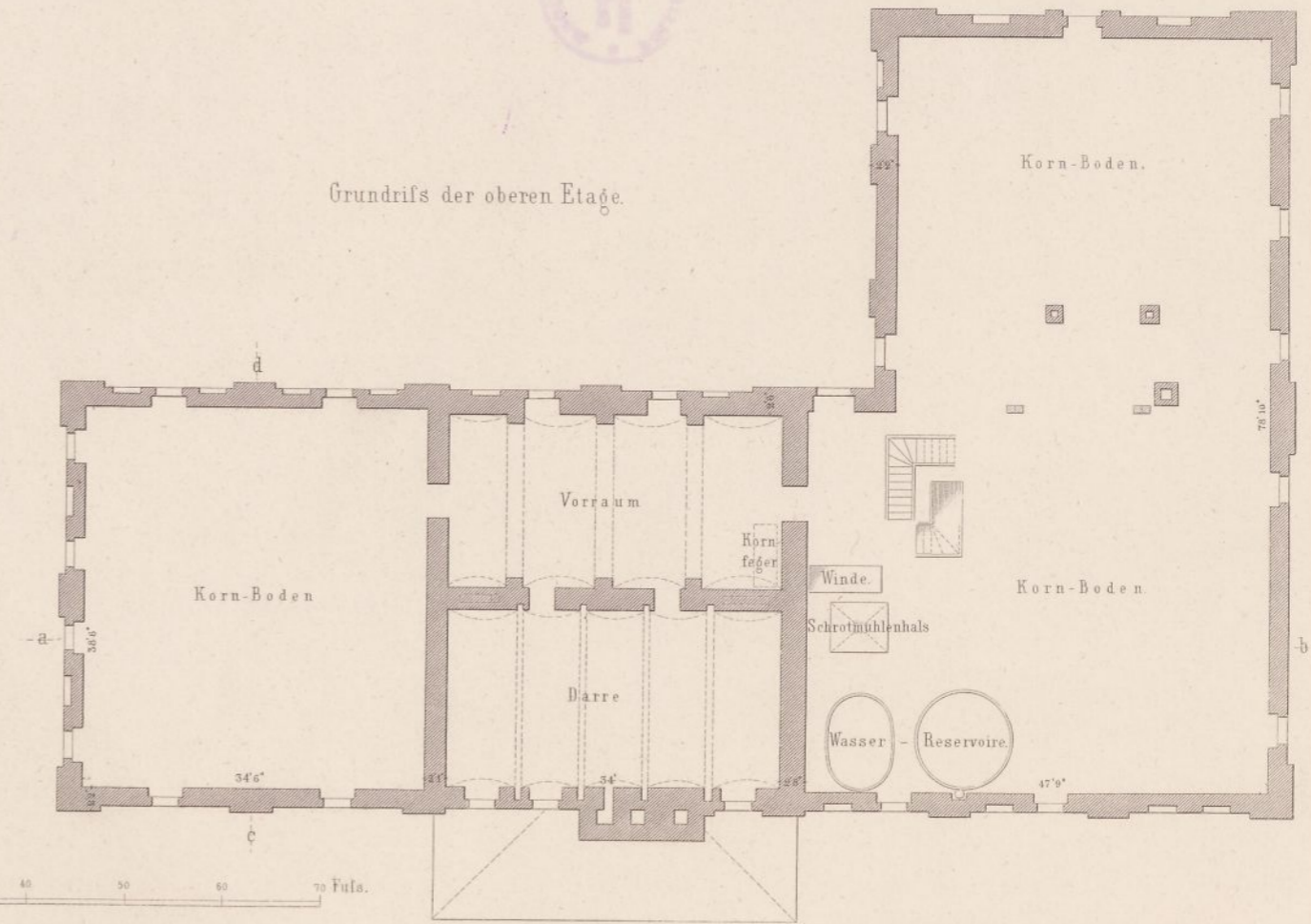

Ernst & Korn in Berlin.

Brauerei-Gebäude  
von E. Wagner bei Berlin.

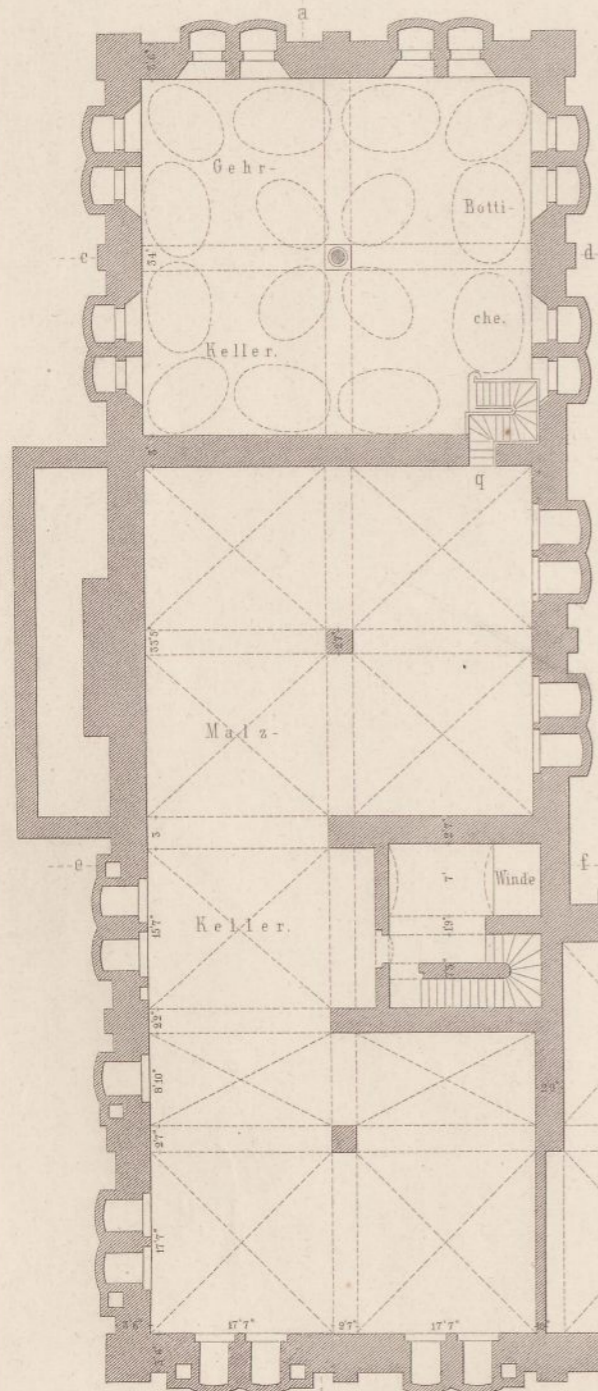

Grundriss des oberen Kellers.

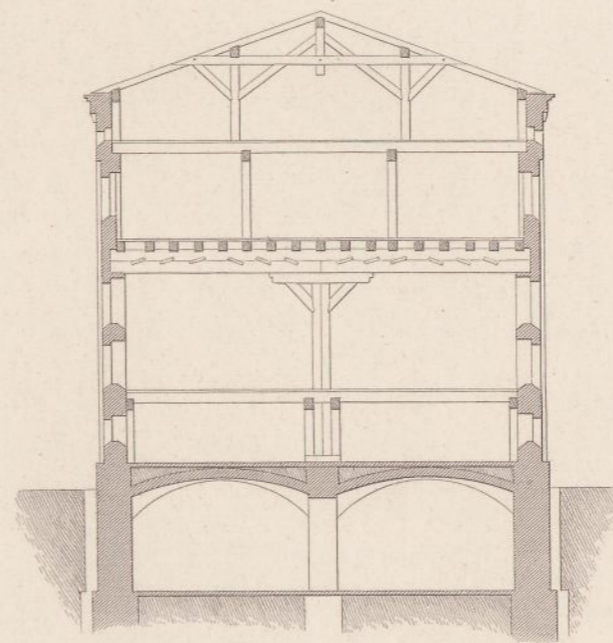

Durchschnitt nach cd.

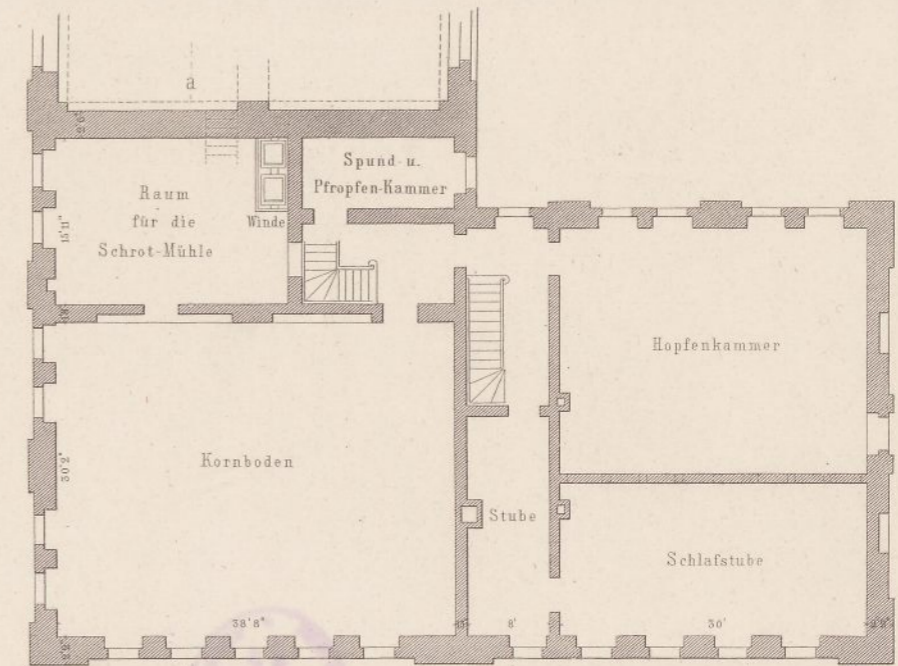

Grundriss der Zwischen-Etage.

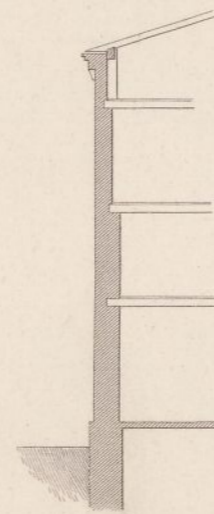

Durchschnitt nach ef.

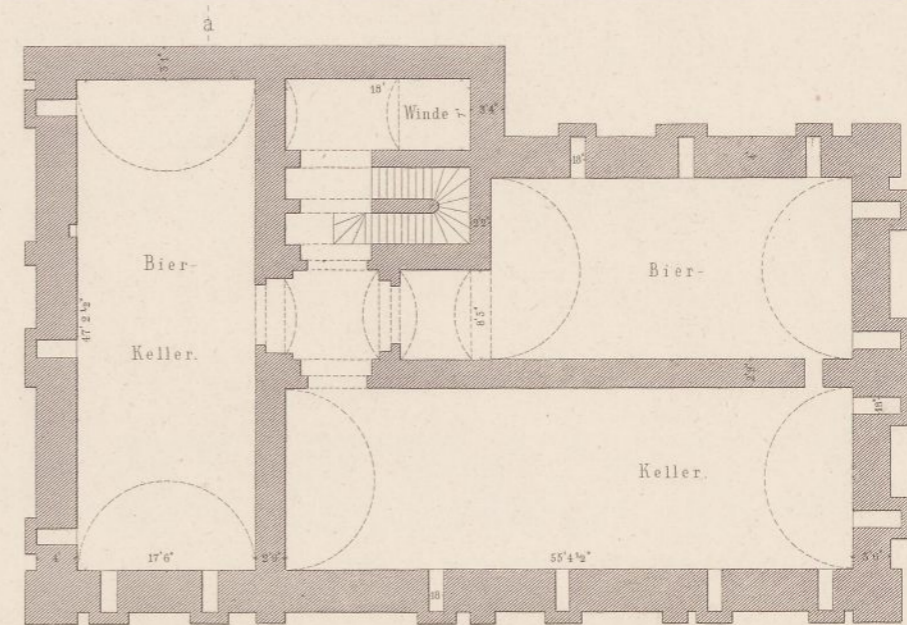

Grundriss des unteren Kellers.



Brauerei-Gebäude  
von E. Wagner bei Berlin.

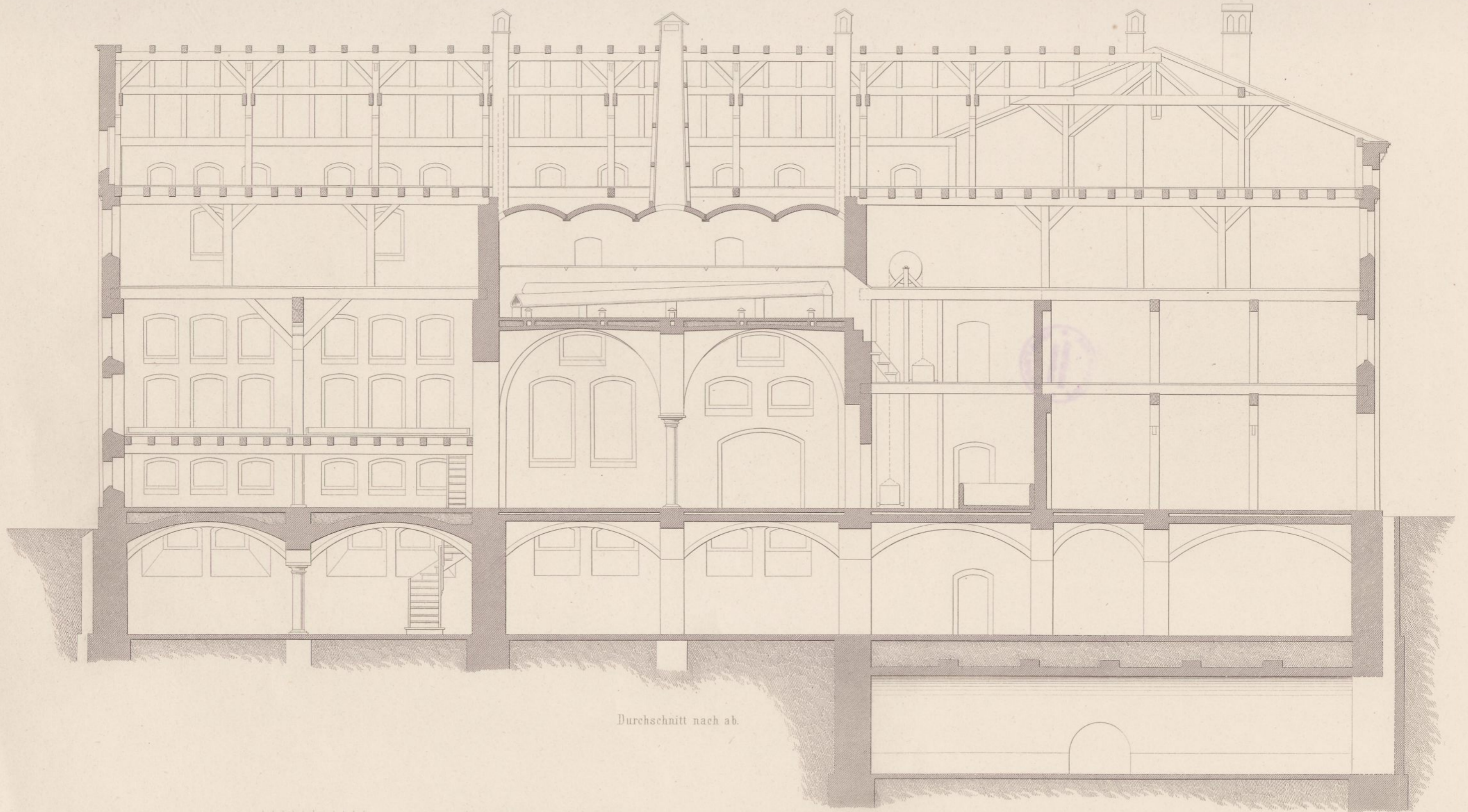

Durchschnitt nach ab.

Fufs 10 5 0 10 20 30 40 50 60 70 80 Fufs.

Ernst & Korn in Berlin.



# DECKEN-DECORATION

im

„Salon des Sept Cheminées“ des Louvre zu Paris.



Kirche zu Brodowin.

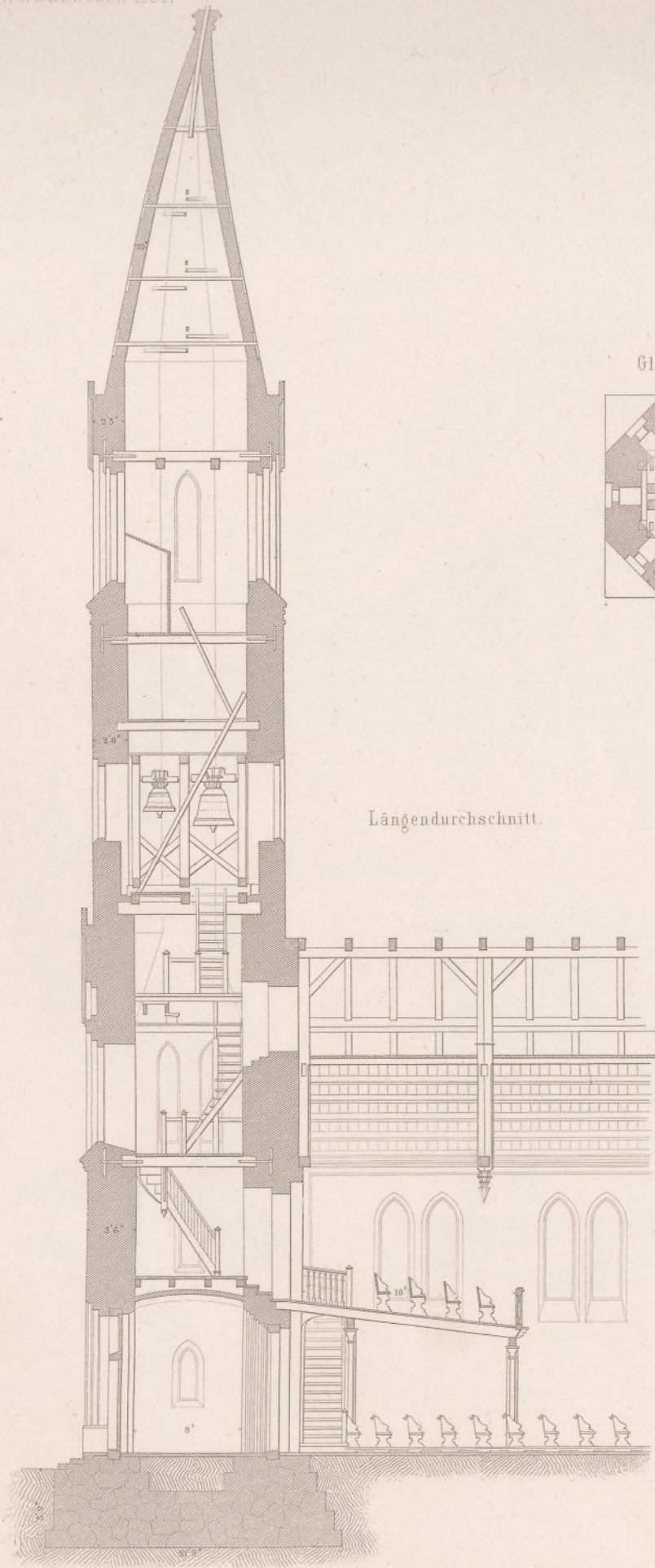

Längendurchschnitt.

Glocken-Etage.

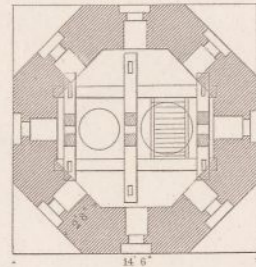

Grundriss.

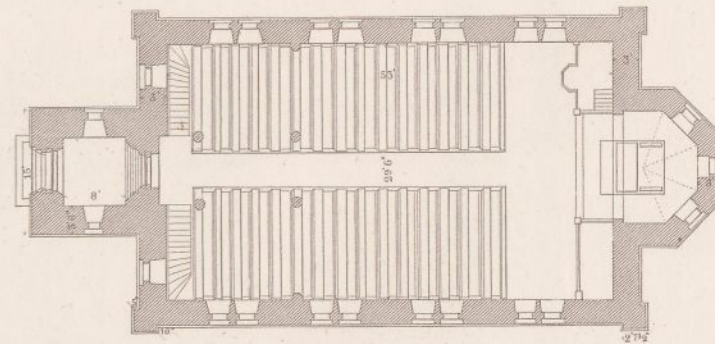

0 5 10 20 30 40 50 Fuß.

Ansicht des Chors.

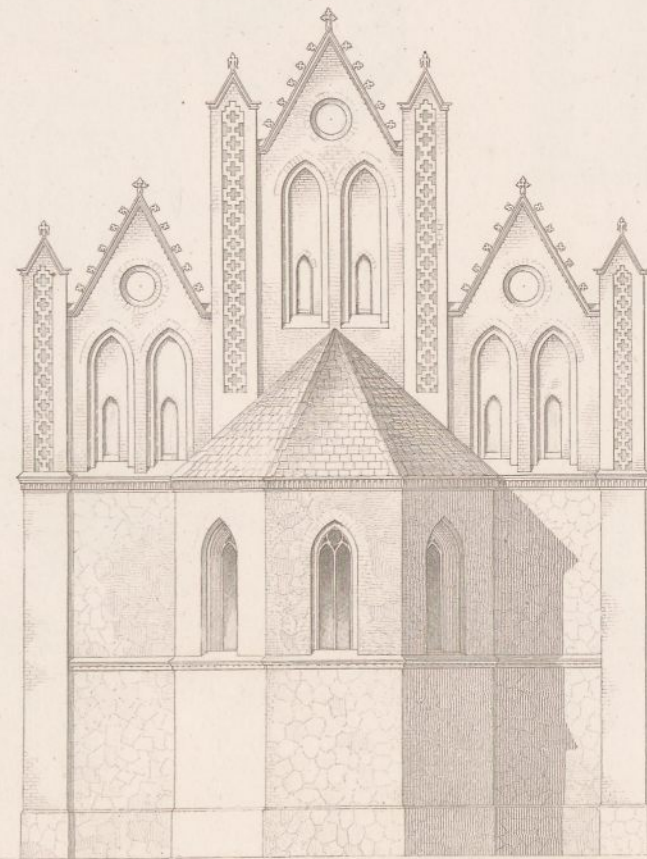

0 10 20 30 40 50 Fuß.

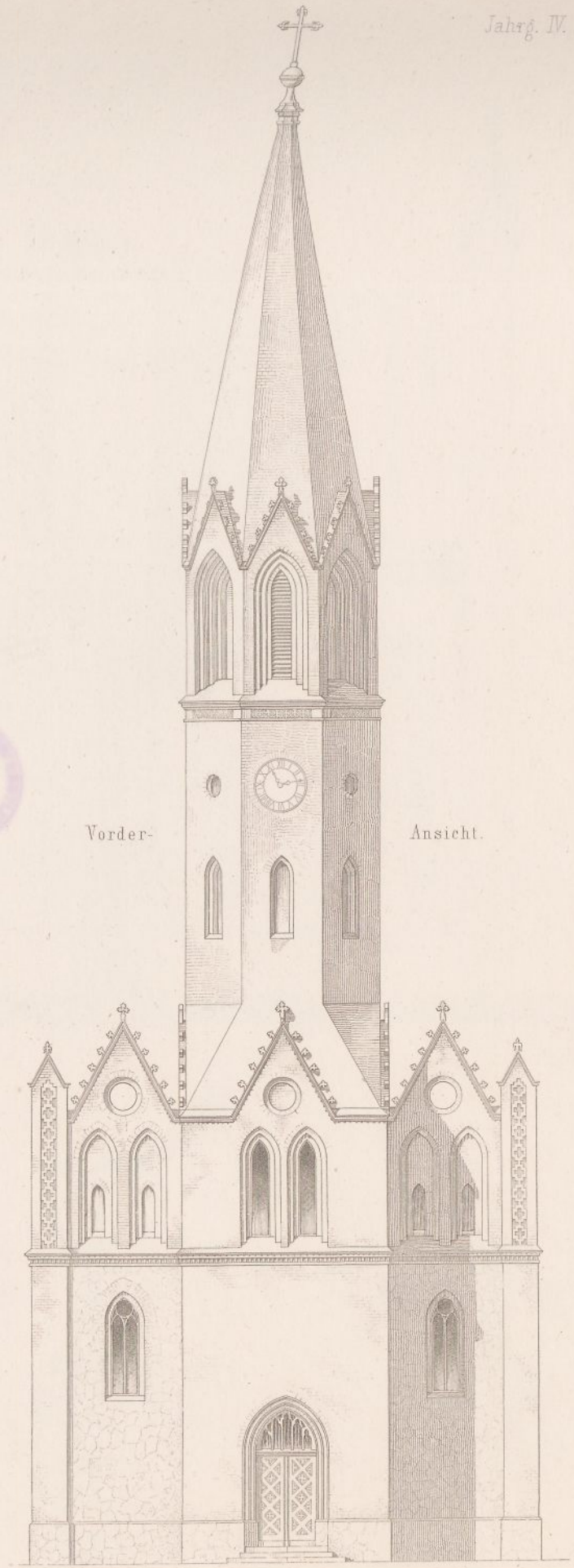

Vorder-

Ansicht.

Fig. 4.  
Quersprossen  
der Fenster.

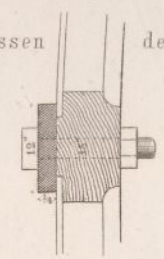

Fig. 1. Hängewerk.

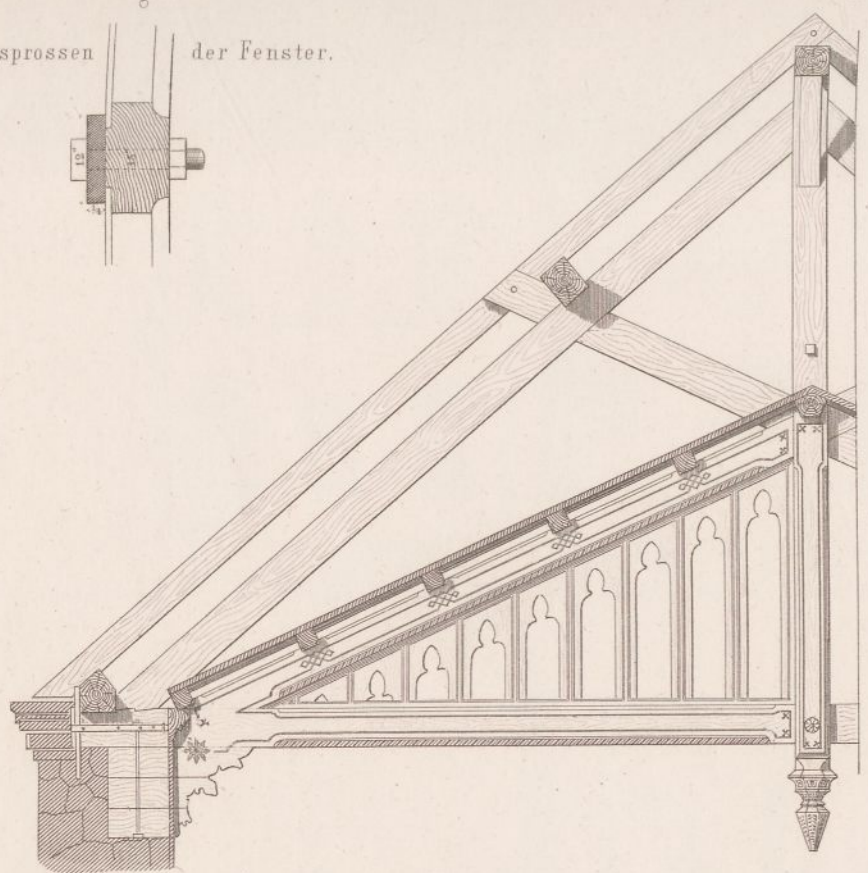
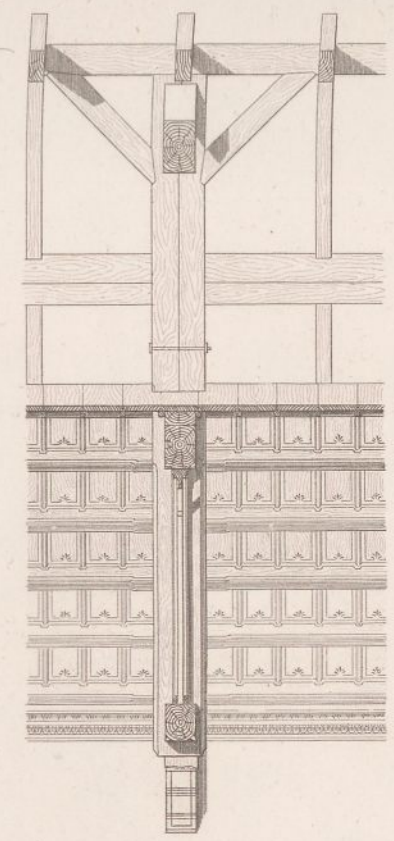

Fig. 2. Chorbrüstung.

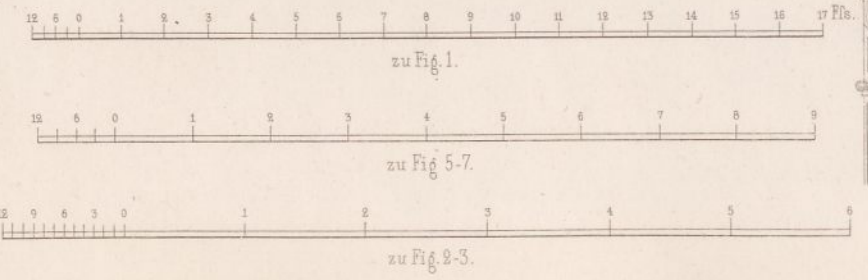
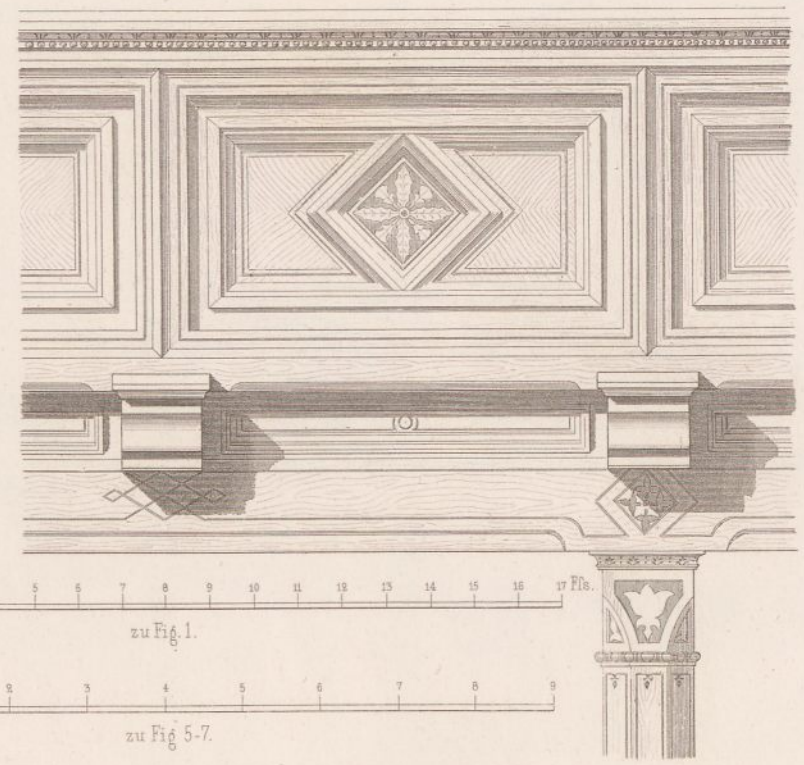
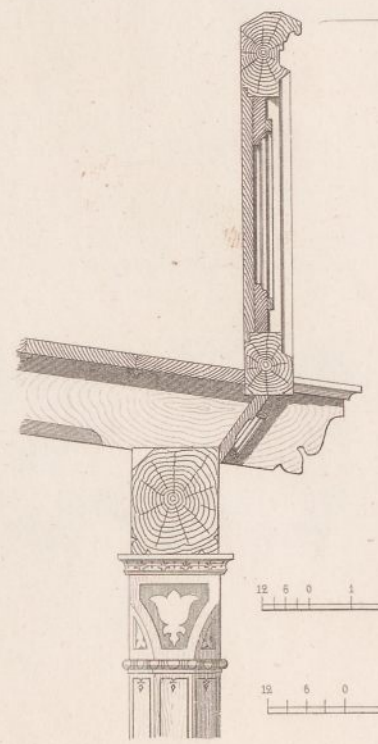

Fig. 3. Kanzel.

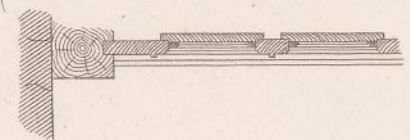
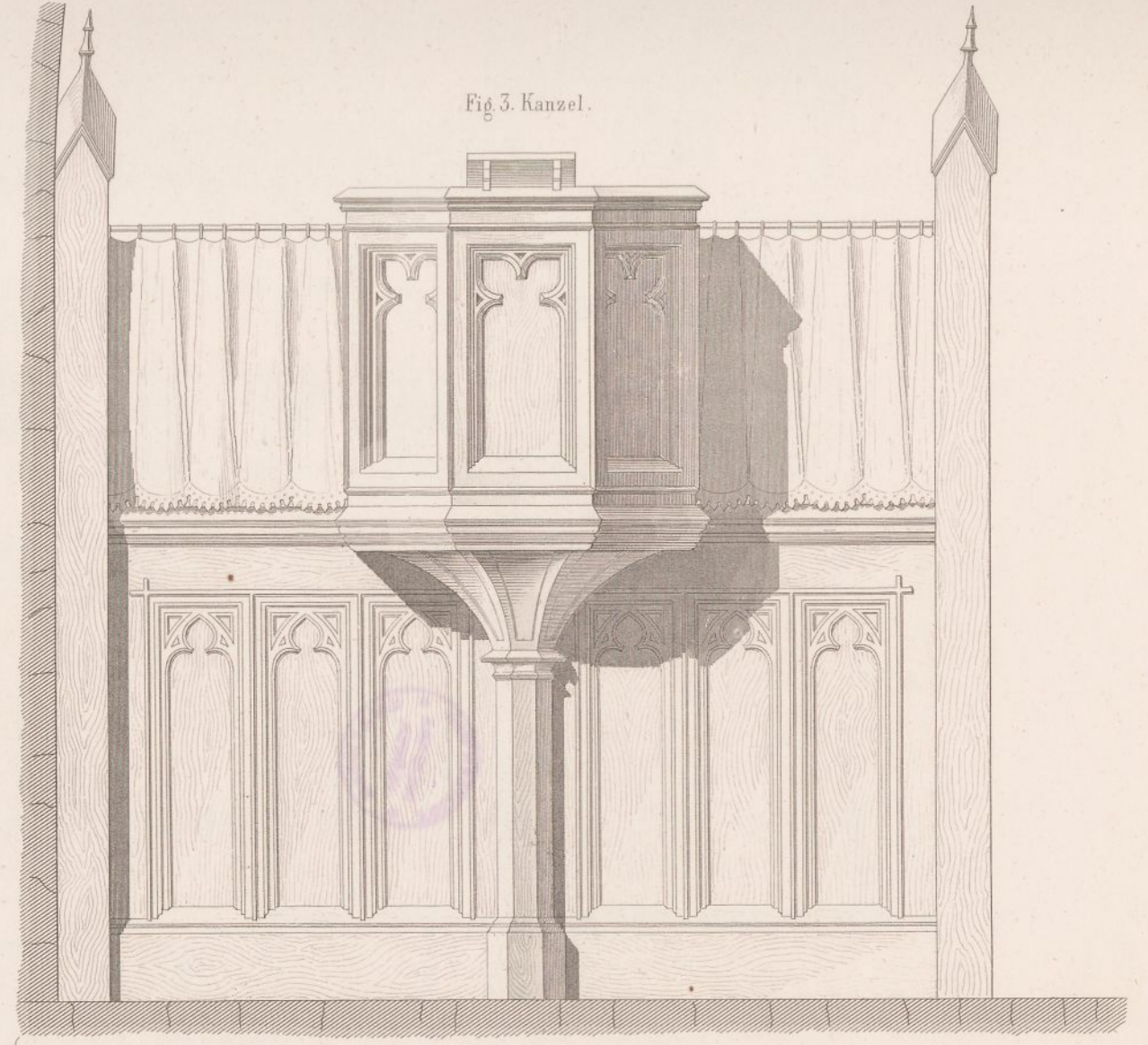

Fig. 5.



Fig. 6.

Giebel-Decorationen.

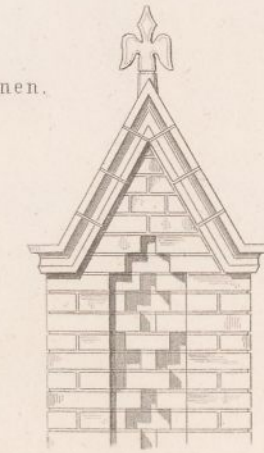
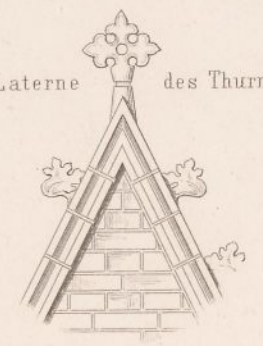

Fig. 7.

Laterne des Thurms.



Gebäude für Tobsüchtige.

Ansicht.

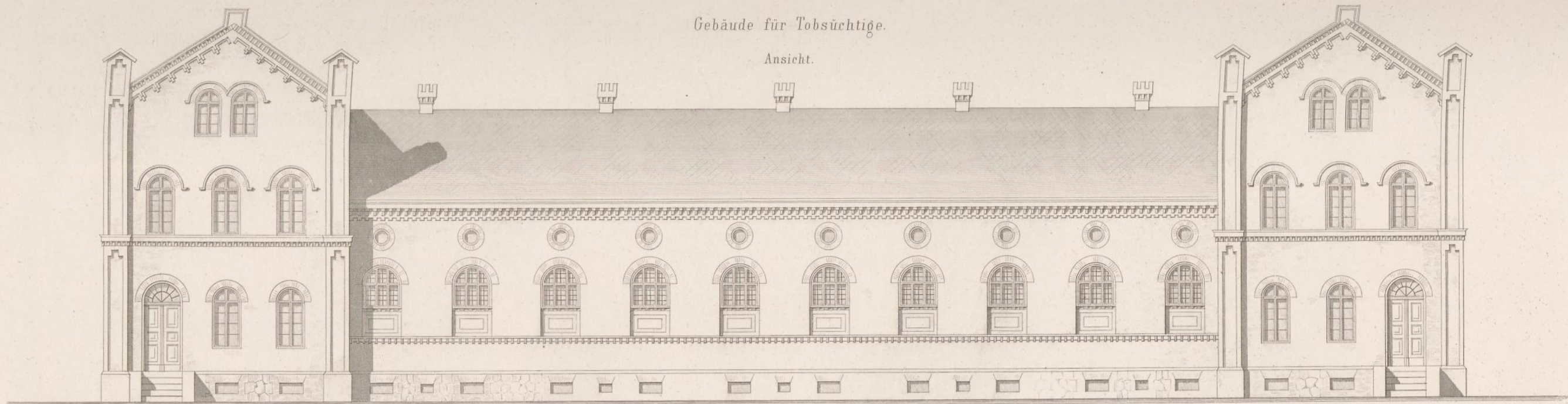

10 20 30 40 50 60 70 80 90 100 Fuss rheinl.

Grundriss des Erdgeschosses

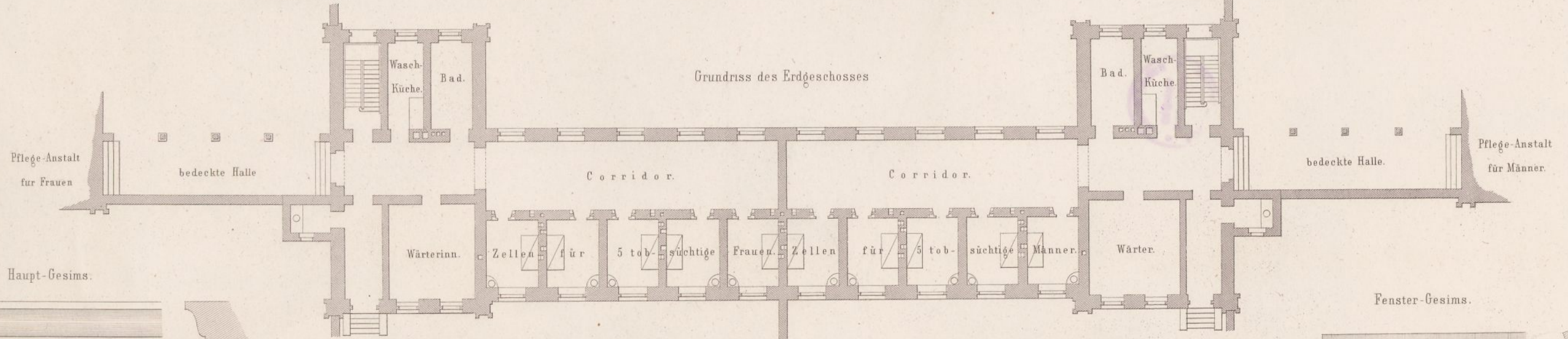

10 20 30 40 50 60 70 Fuss rhl.

Grundriss des Kellergeschosses

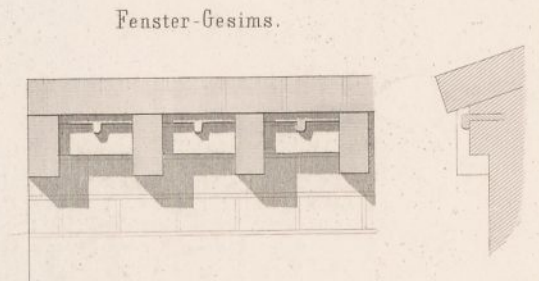
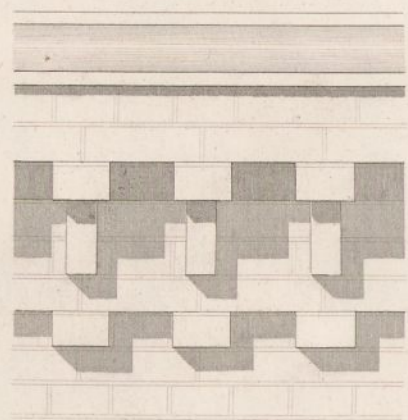

10 20 30 40 50 60 70 Fuss.

Irren-Anstalt zu Schwetz.

Allgemeines Wirtschaftsgebäude.



Verbindung der Holzsäulen des Betsaales mit den eisernen Säulen der Küche.

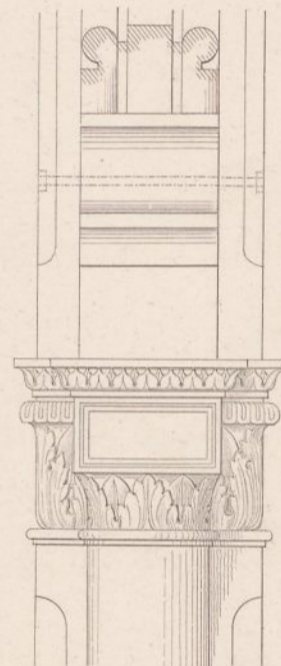
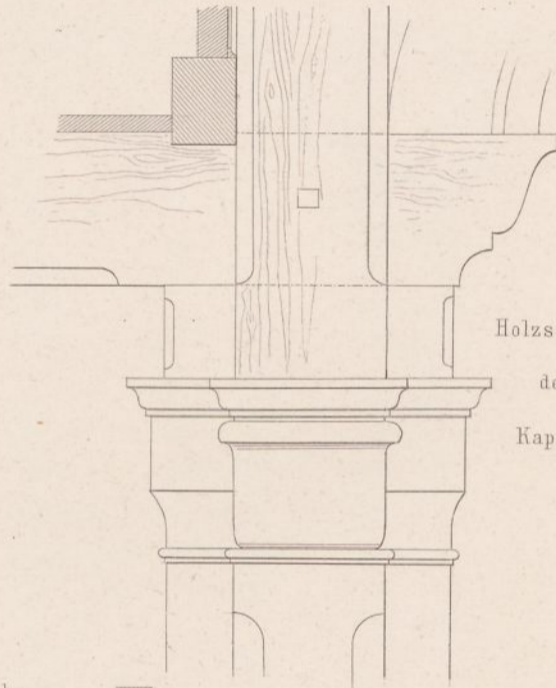
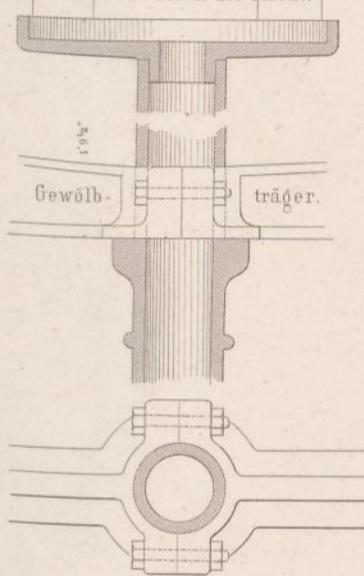

Grundriss der Holzsäulen.

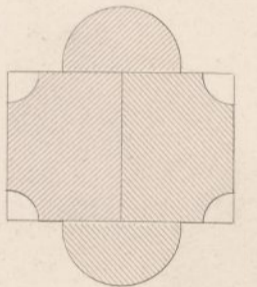

Längen-Durchschnitt durch Kapelle u. Küche

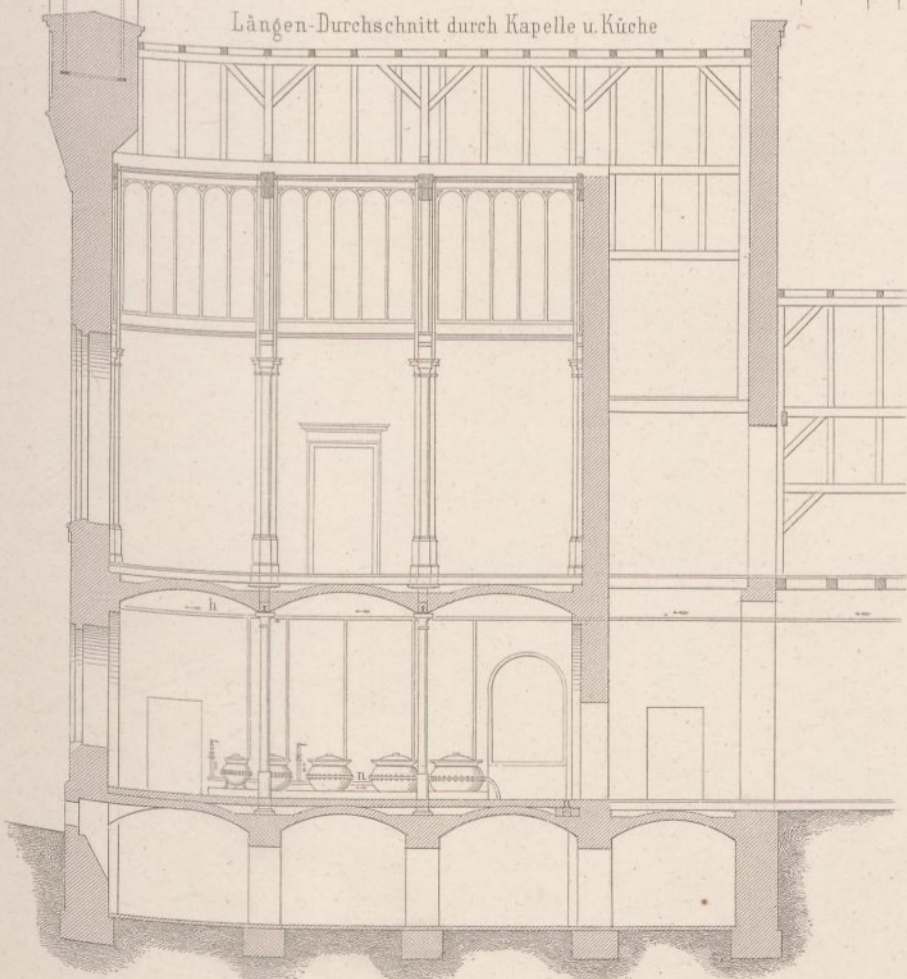

Quer-Durchschnitt durch Kapelle u. Küche

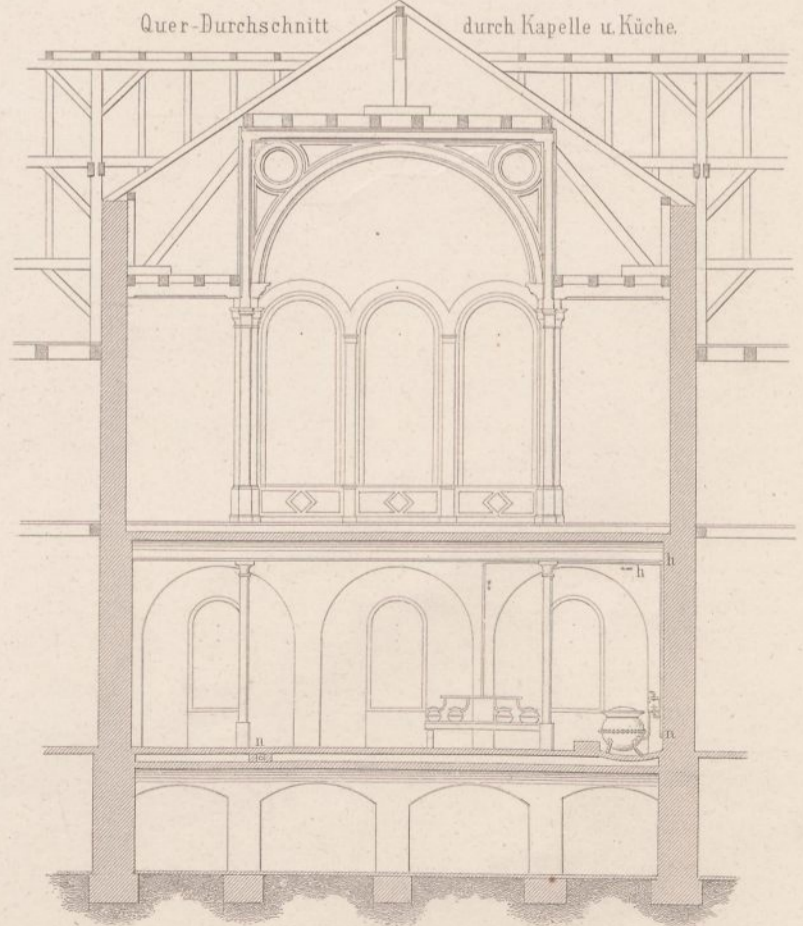

50 Fufs, zu Fig. 1.2.5. 3 Fufs, zu den Details.

Irren-Anstalt zu Schwetz.

Wirtschafts-Gebäude.

Wash-Haus.

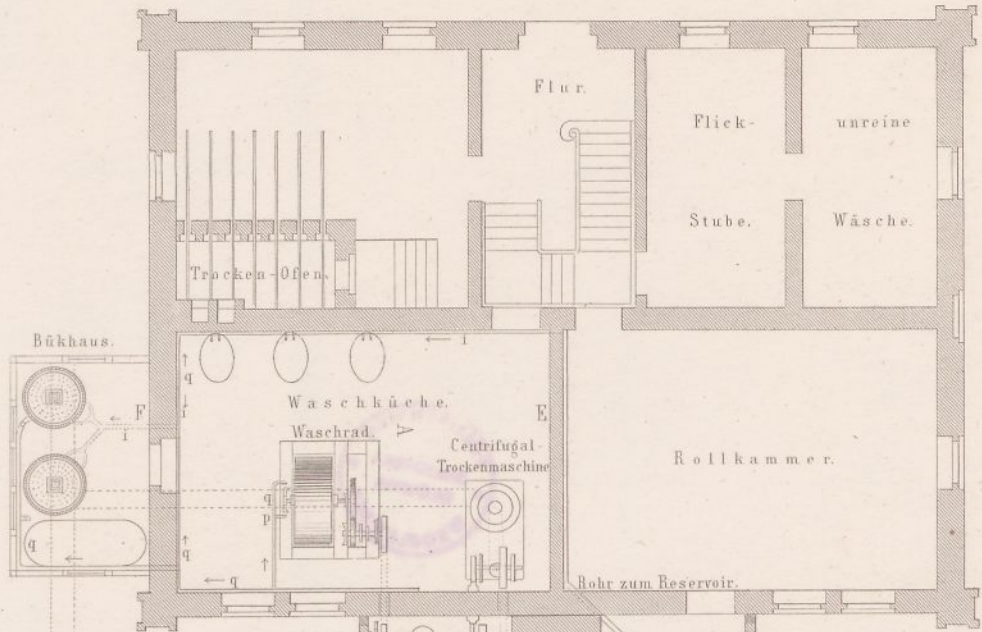

Dampfmaschinen-Haus.

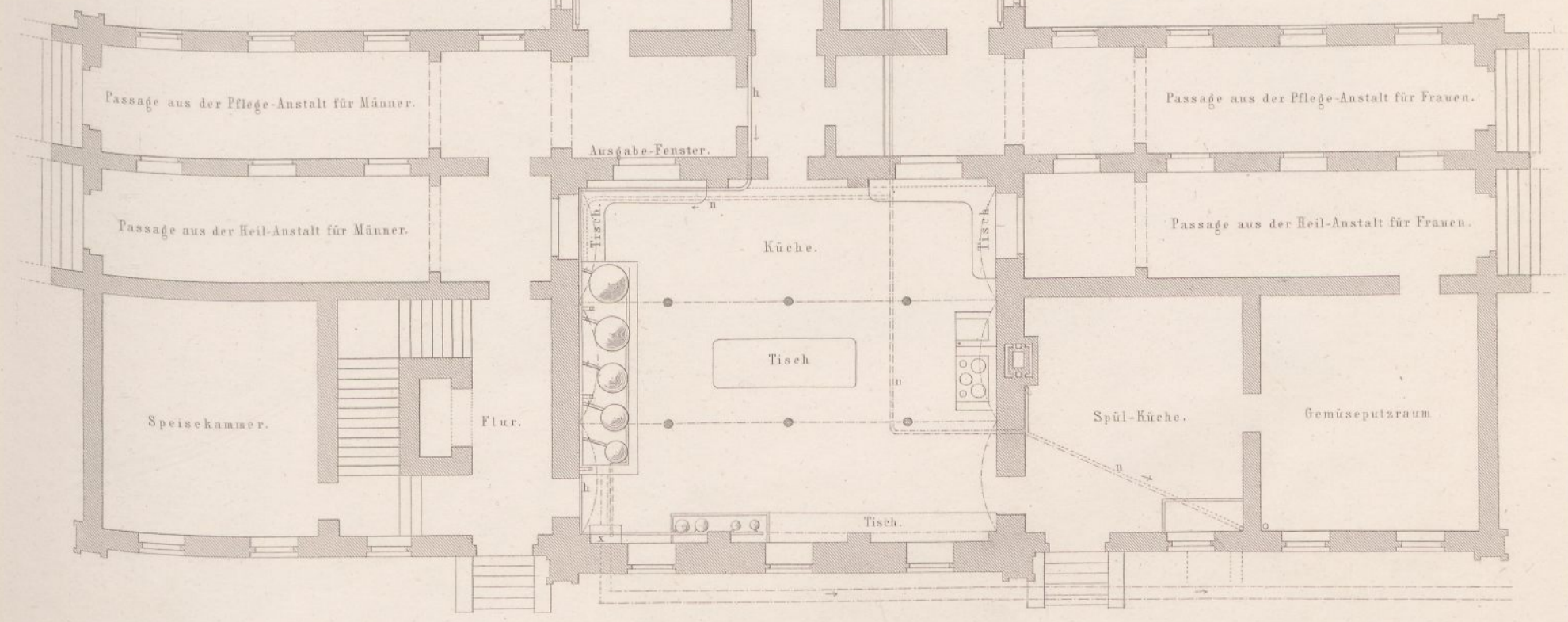
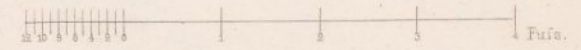
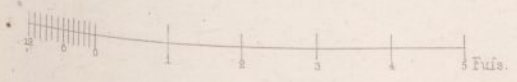
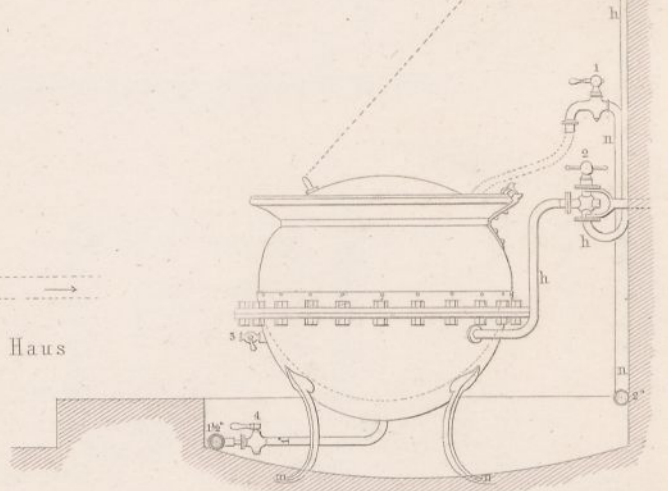
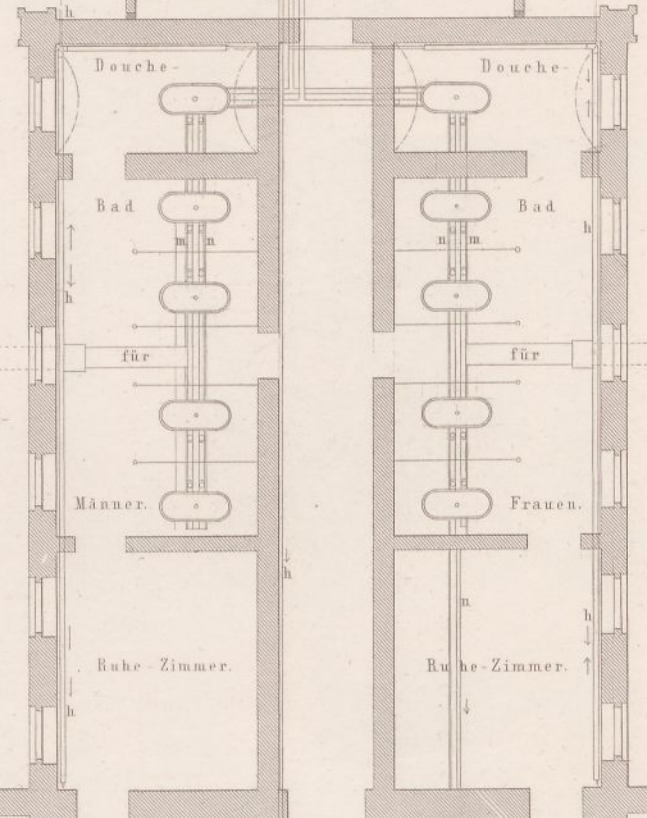
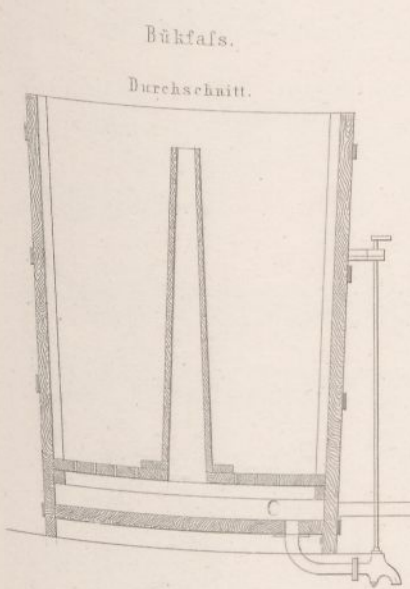
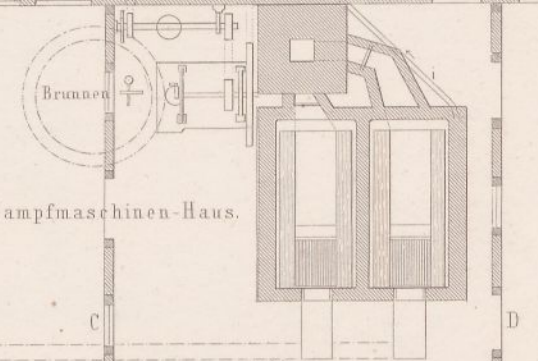

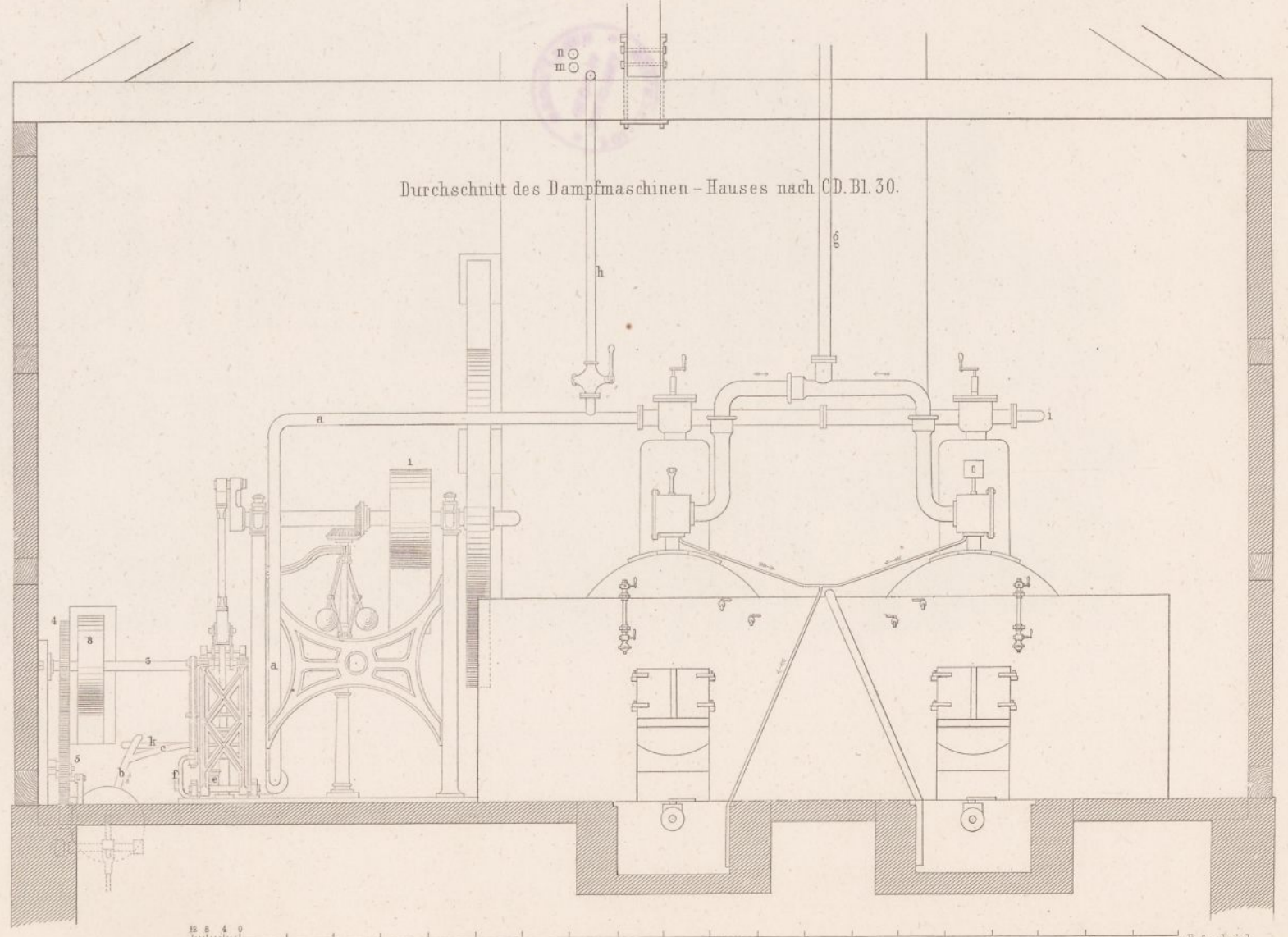
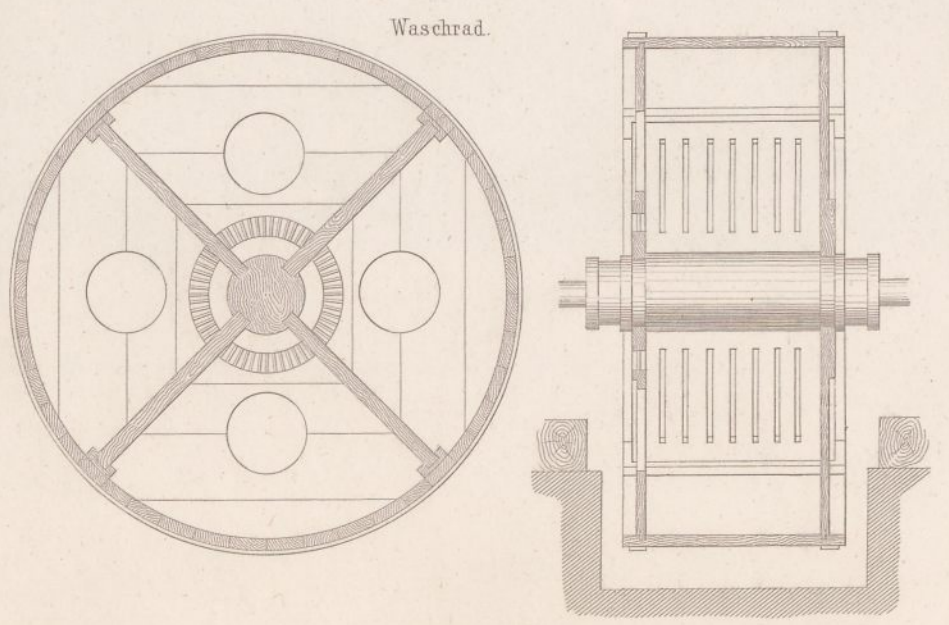
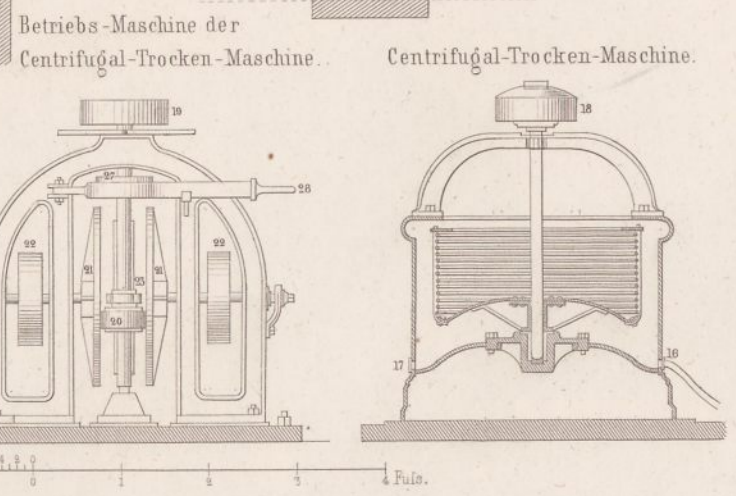
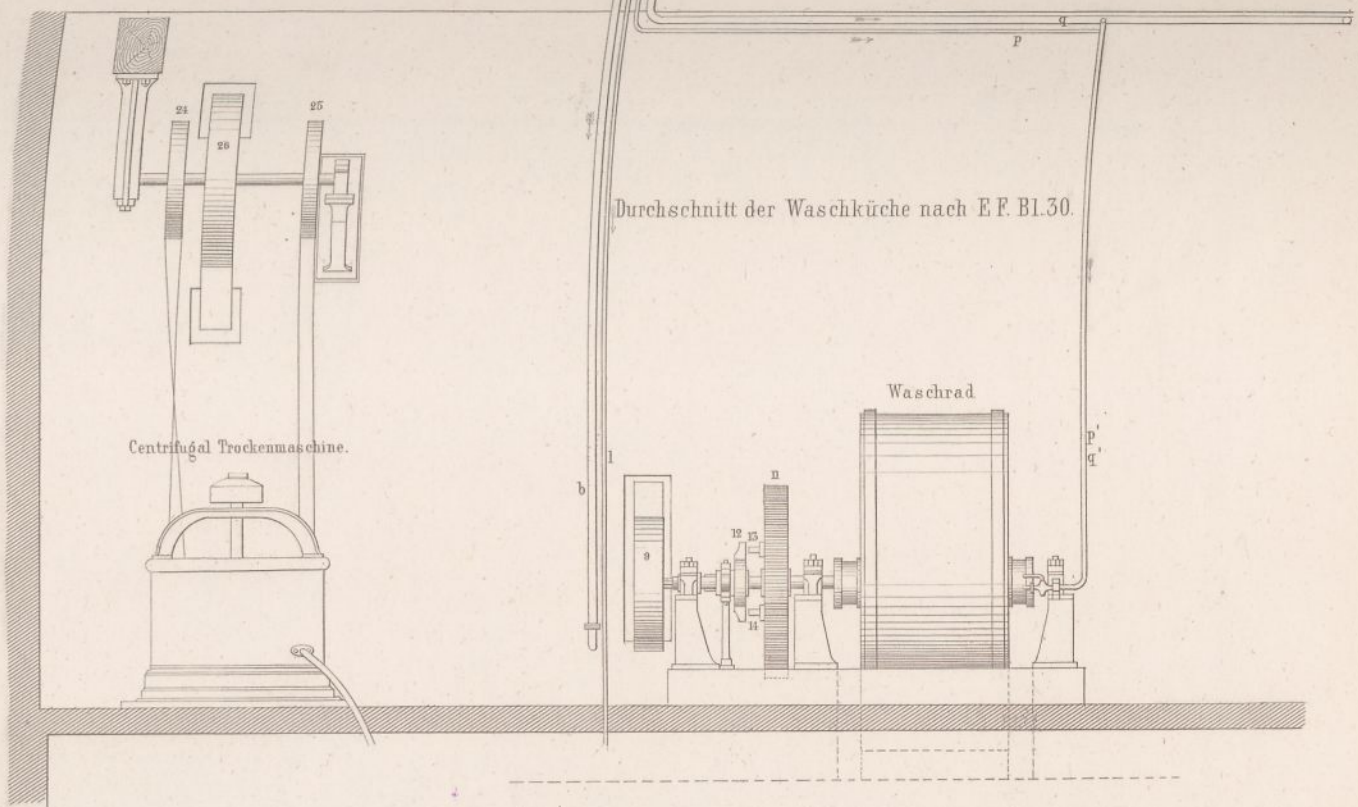
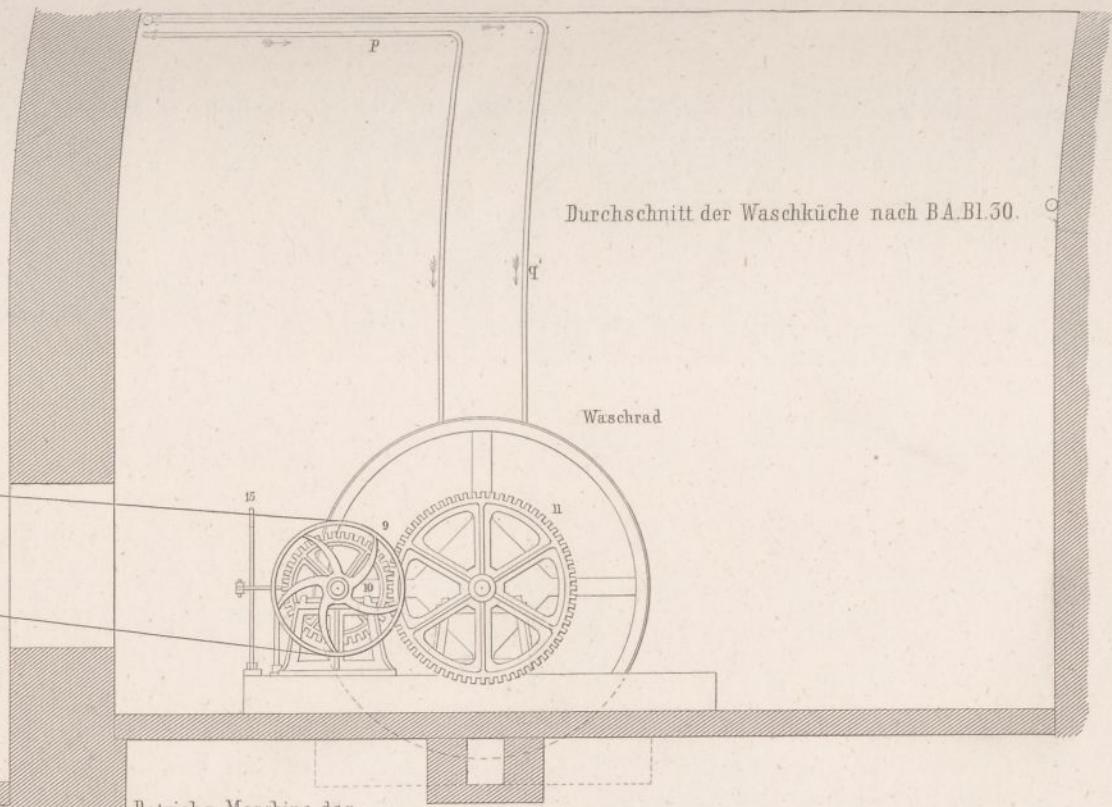



Irren-Anstalt zu Schwetz.



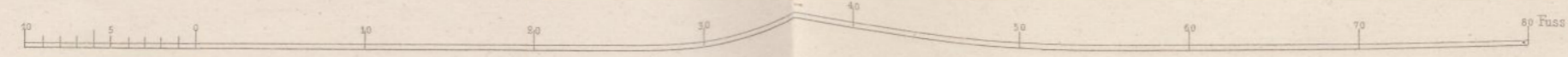
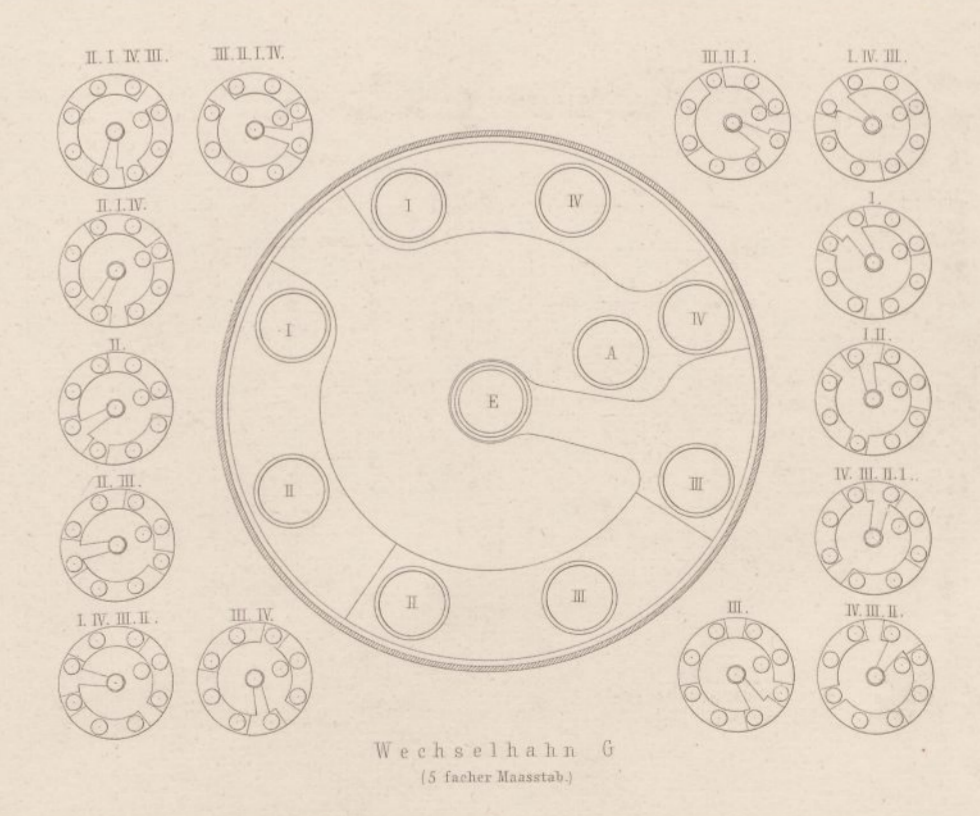
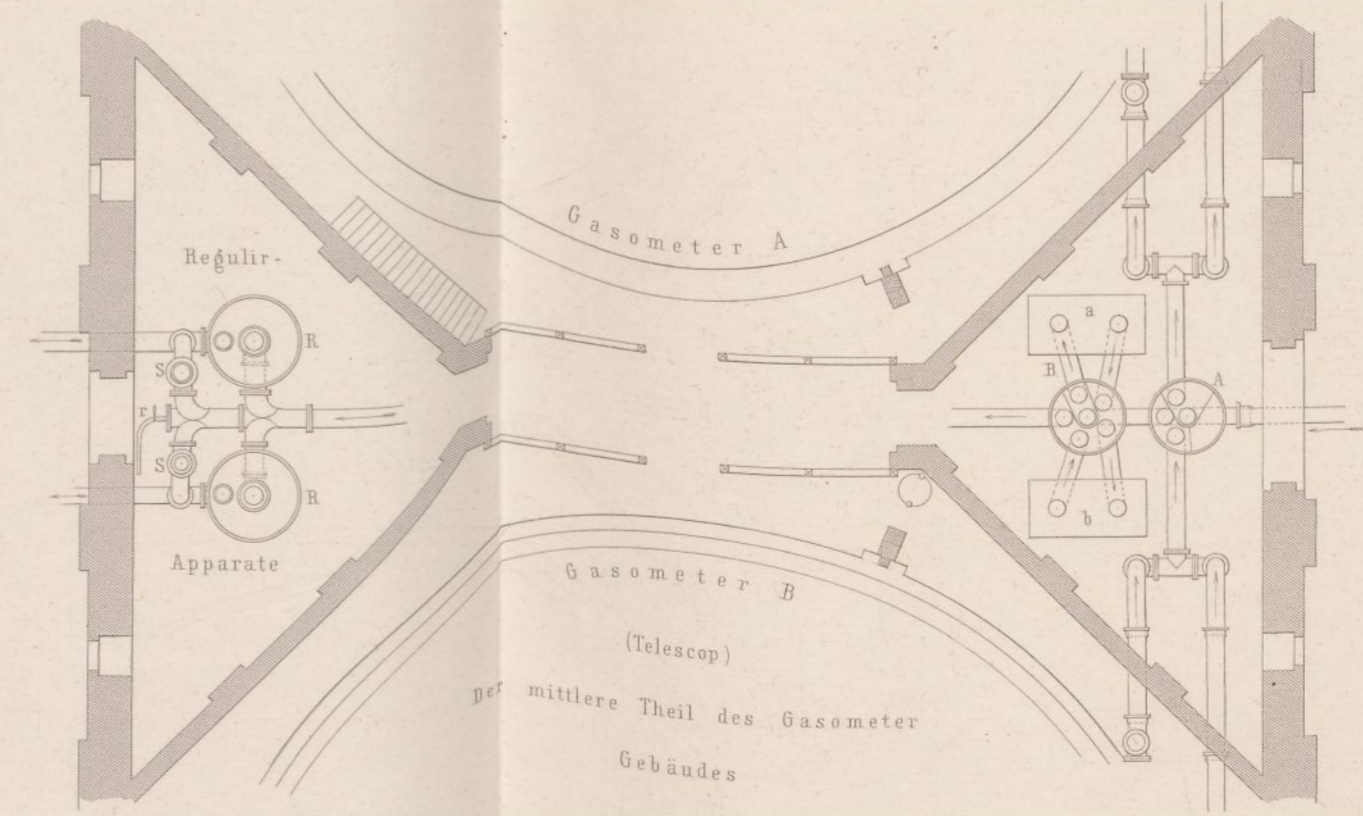
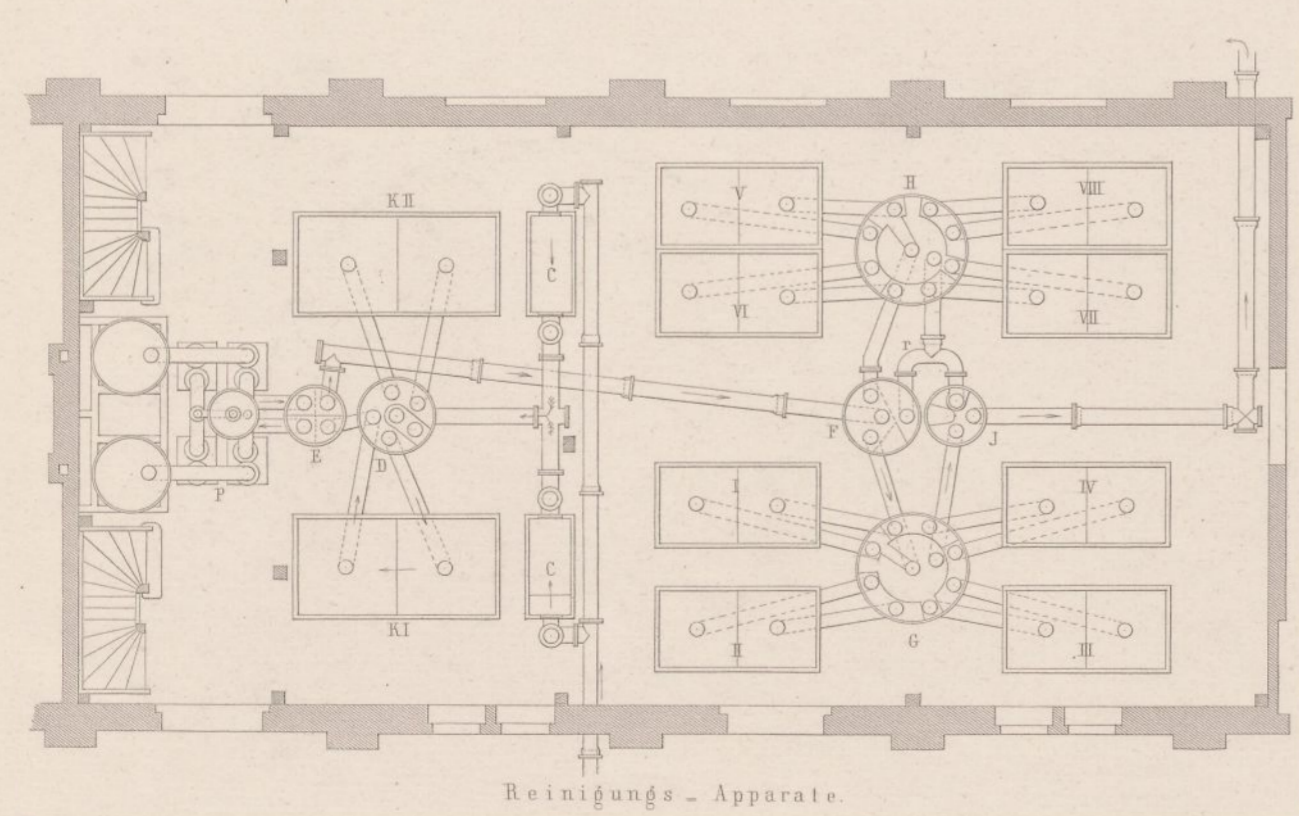
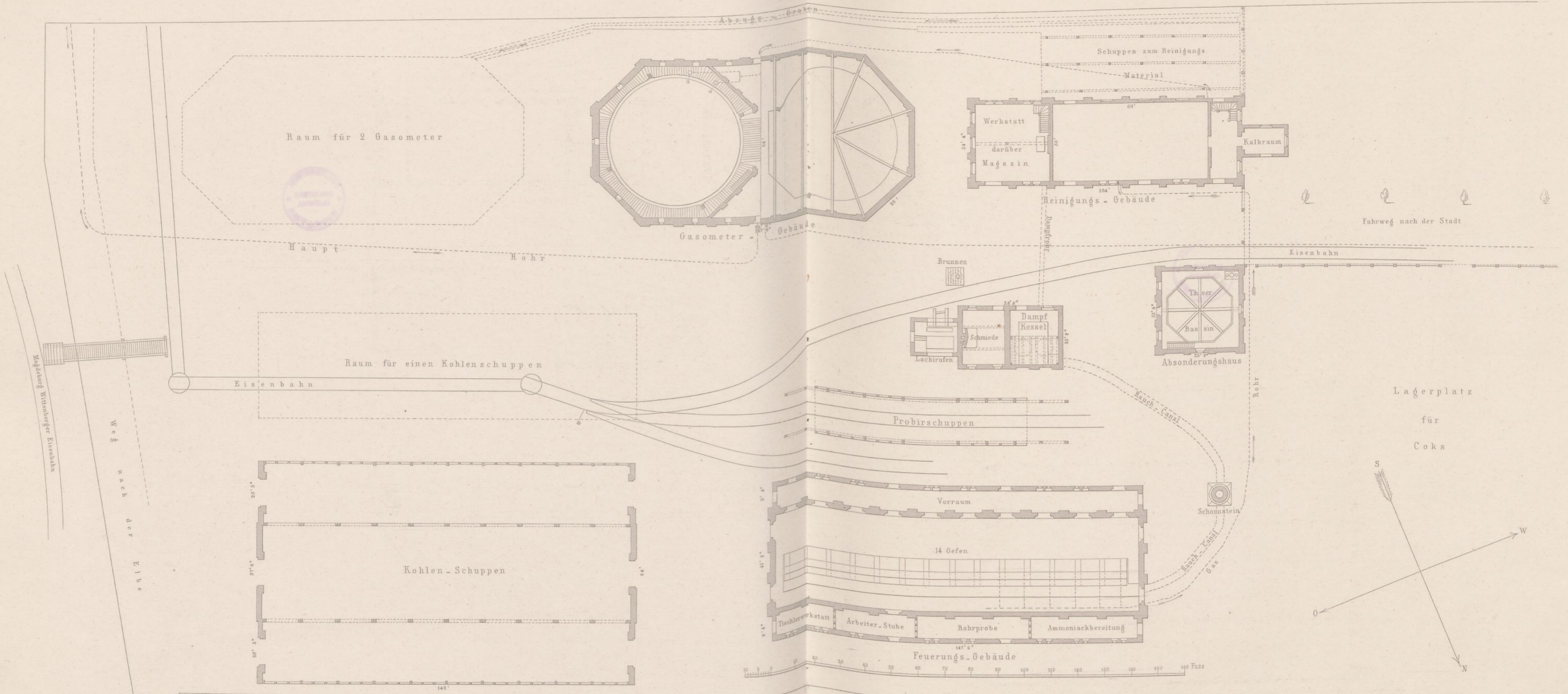

Gas-Anstalt zu Magdeburg.

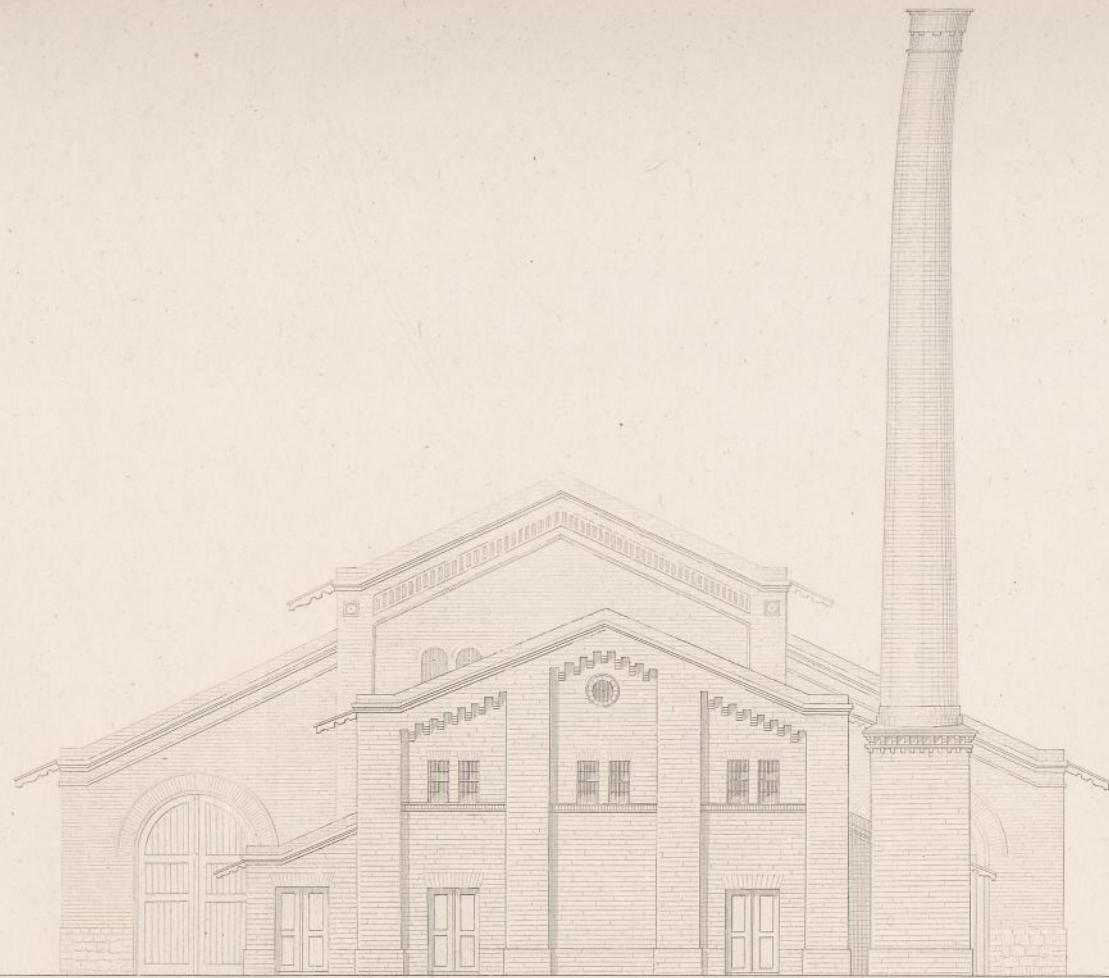

Feuerungsgebäude, dahinter Kohlen-Schuppen.

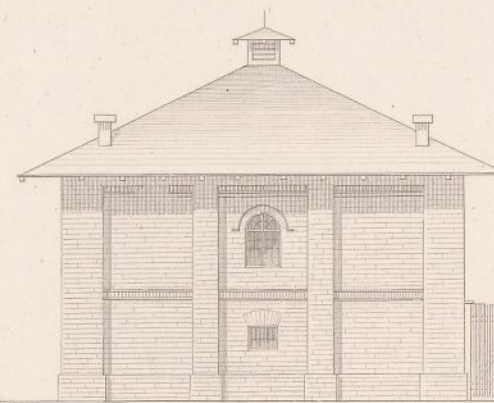

Absonderungs-Haus.

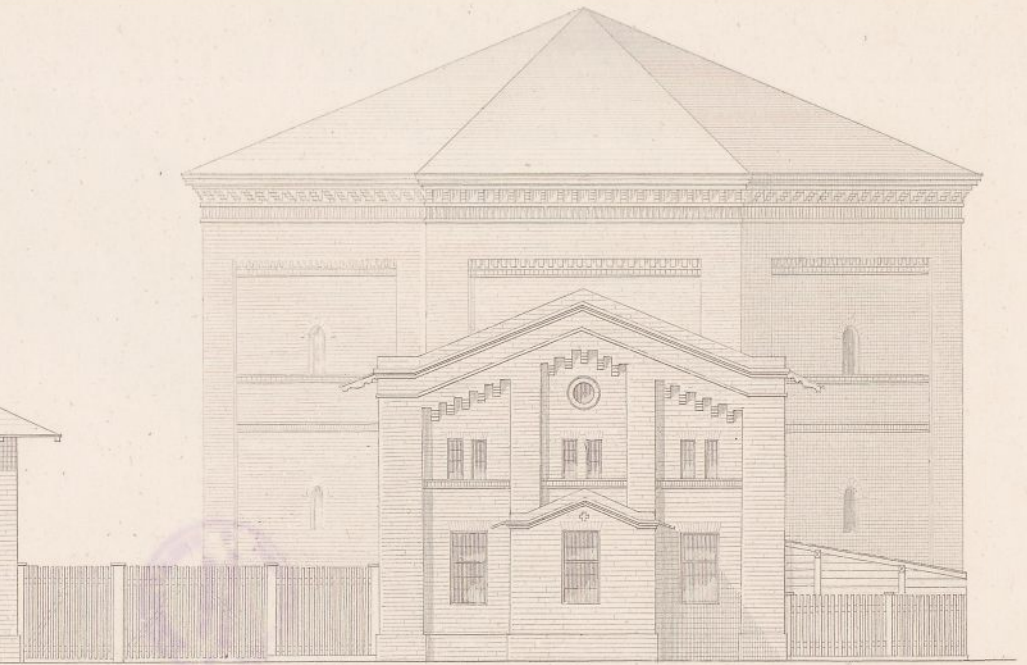

Reinigungs-dahinter Gasometer-Gebäude.

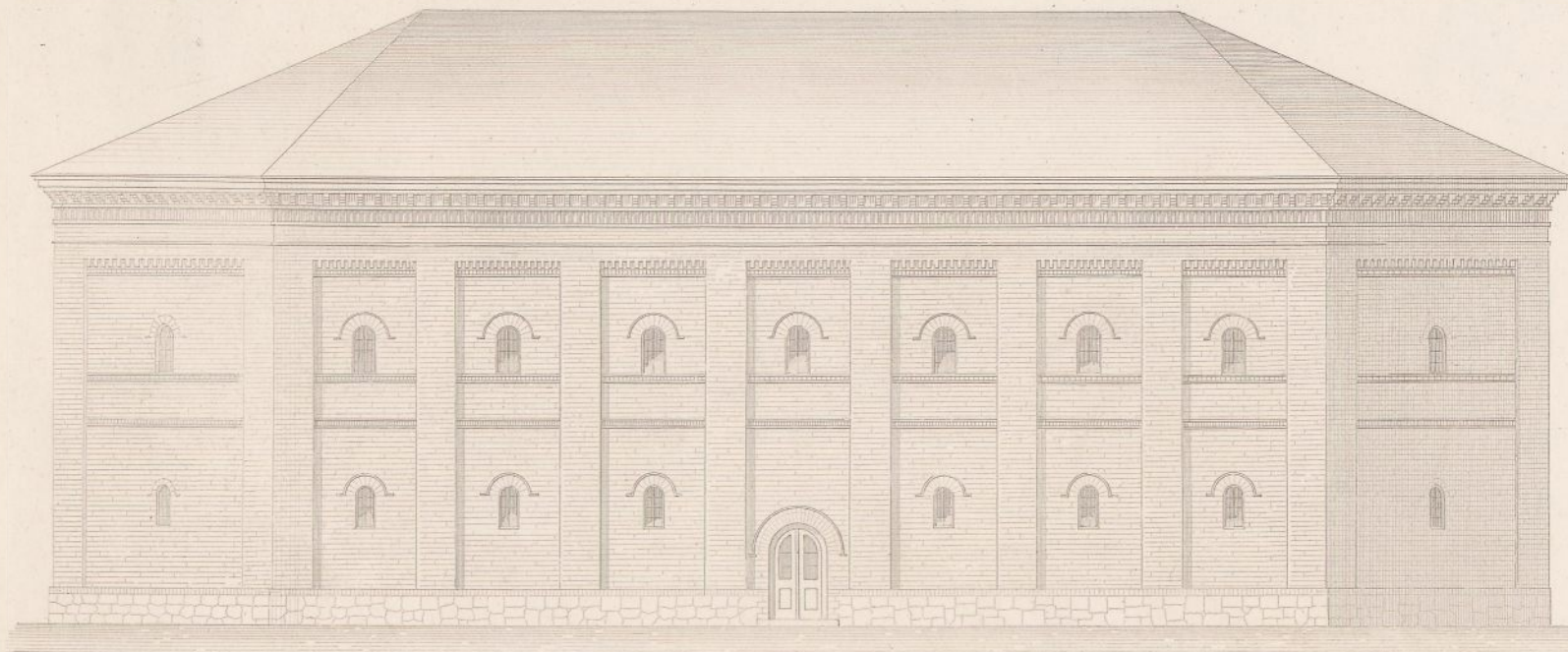

Gasometer-Gebäude.

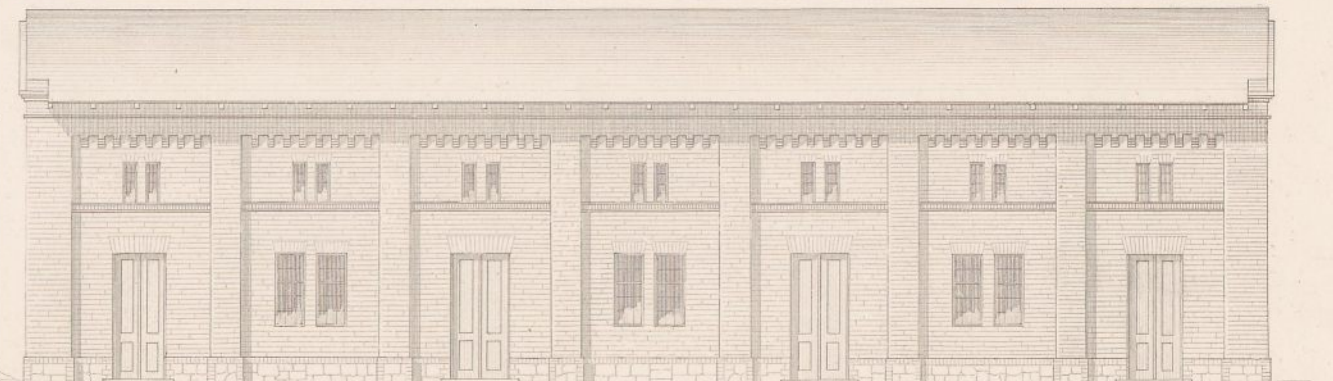

Reinigungs-Gebäude.

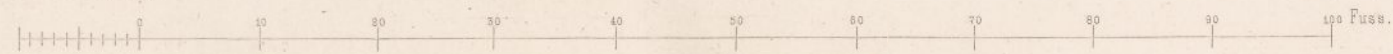

Eiserner Krahn zu Keyham bei Plymouth.

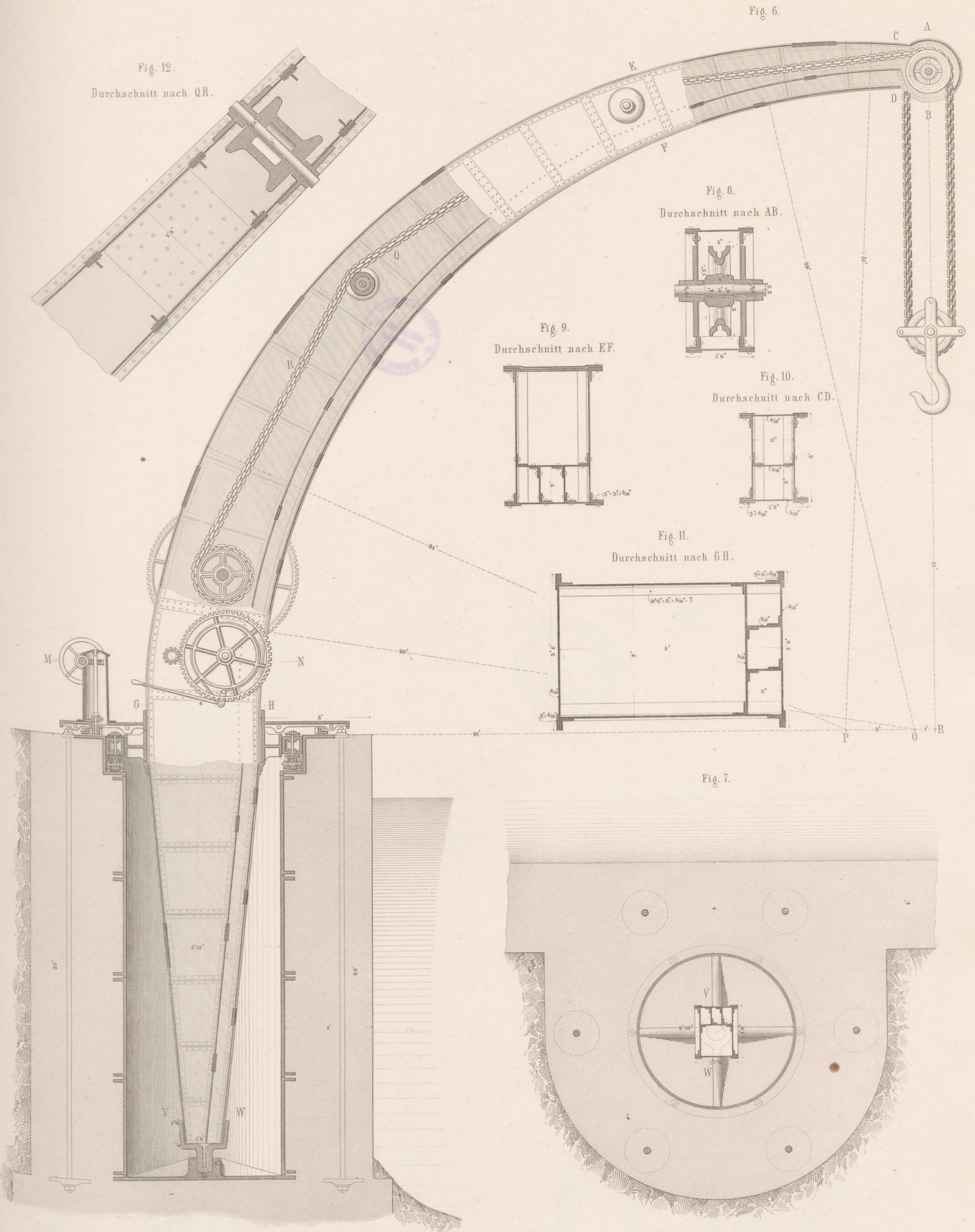

Fig. 12.  
Durchschnitt nach QR.

Fig. 6.

Fig. 8.  
Durchschnitt nach AB.

Fig. 9.  
Durchschnitt nach EF.

Fig. 10.  
Durchschnitt nach CD.

Fig. 11.  
Durchschnitt nach GH.

Fig. 7.

Mafsstab zu Fig. 6. u. 7.

Mafsstab zu Fig. 8. bis 12.

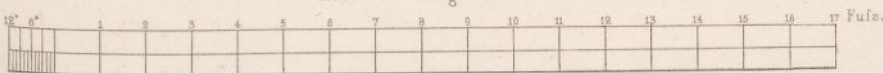

Fig. 5.

Durchschnitt nach JK.

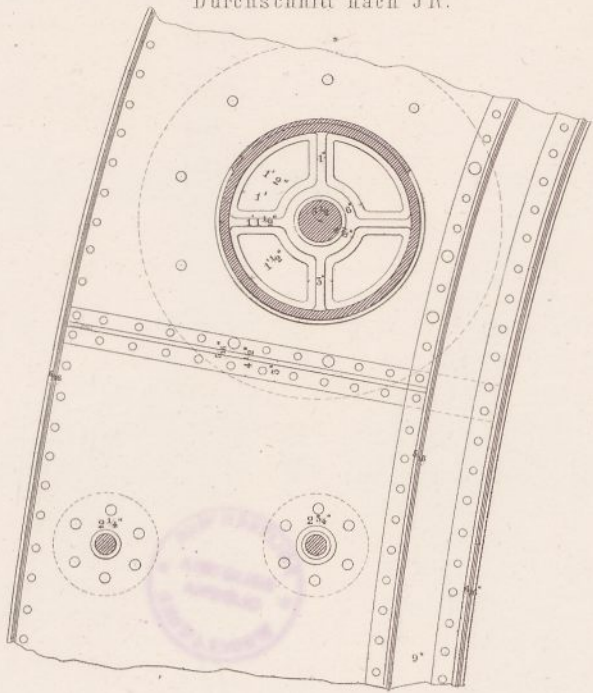

Fig. 1.

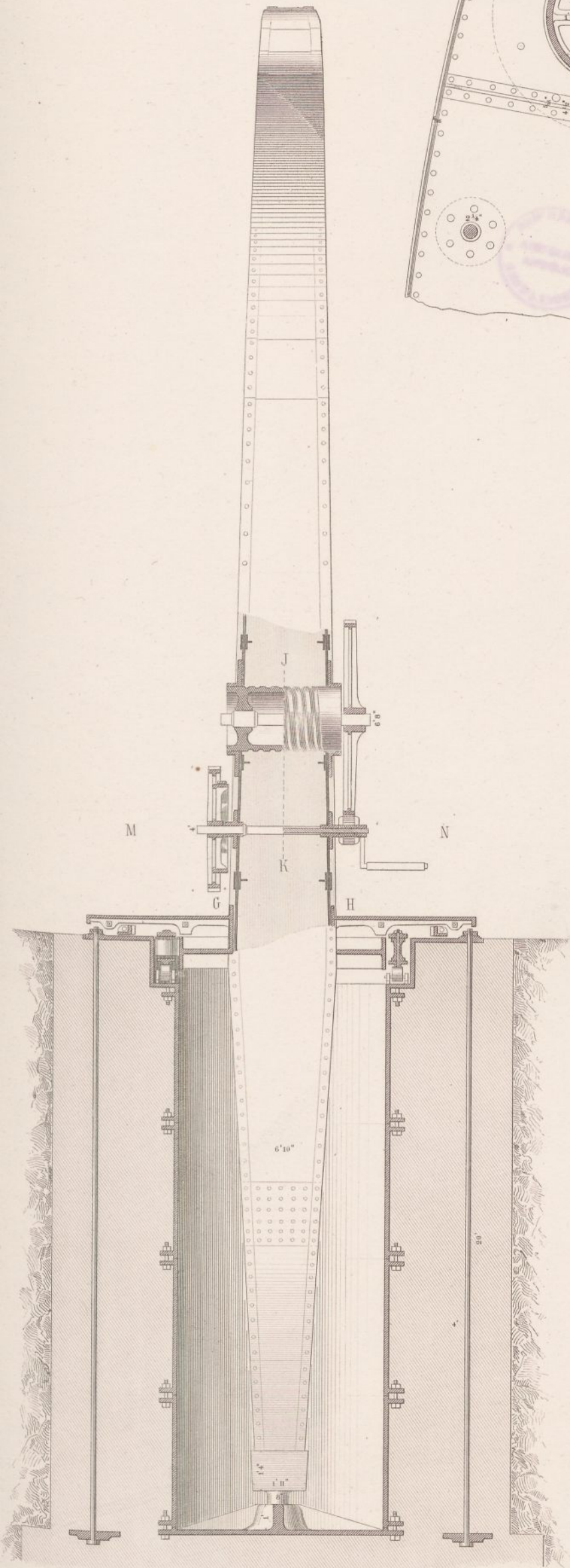

Fig. 2.

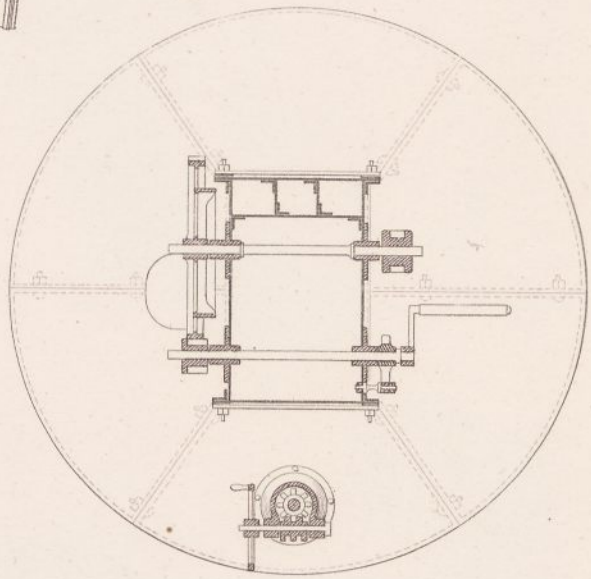

Fig. 3.

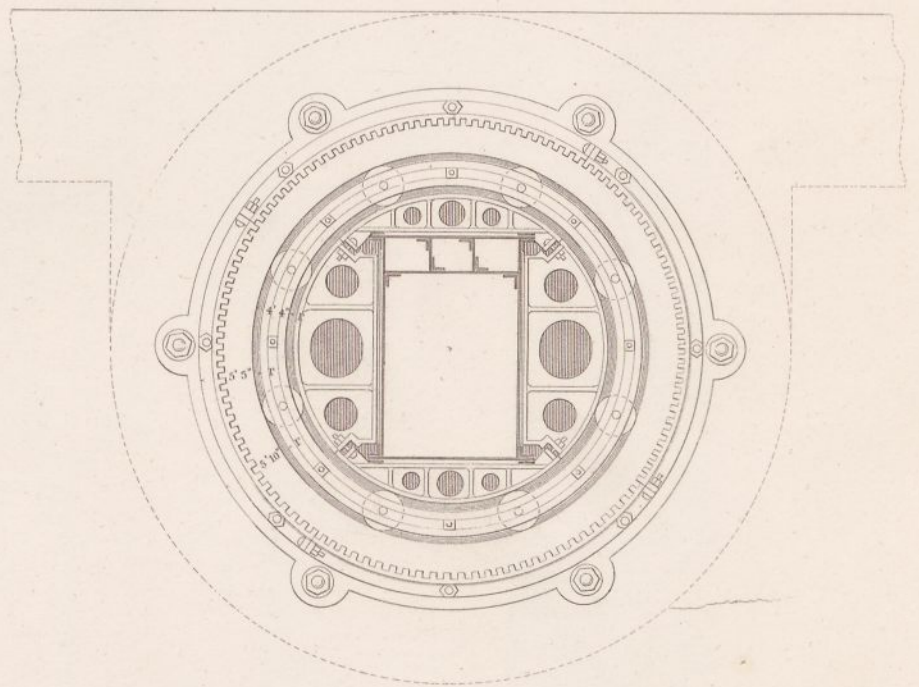
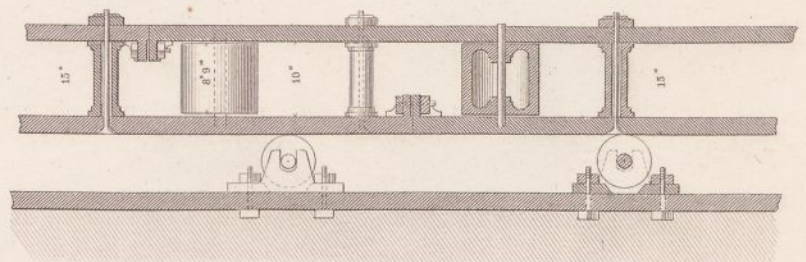
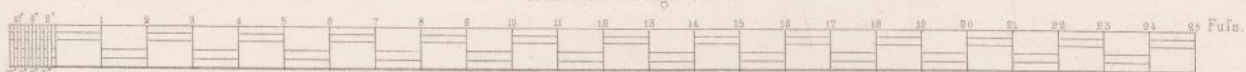

Fig. 4.

Durchschnitt des Walzenkranzes.



Maßstab zu Fig. 1 bis 3.



Gas-Anstalt zu Magdeburg.

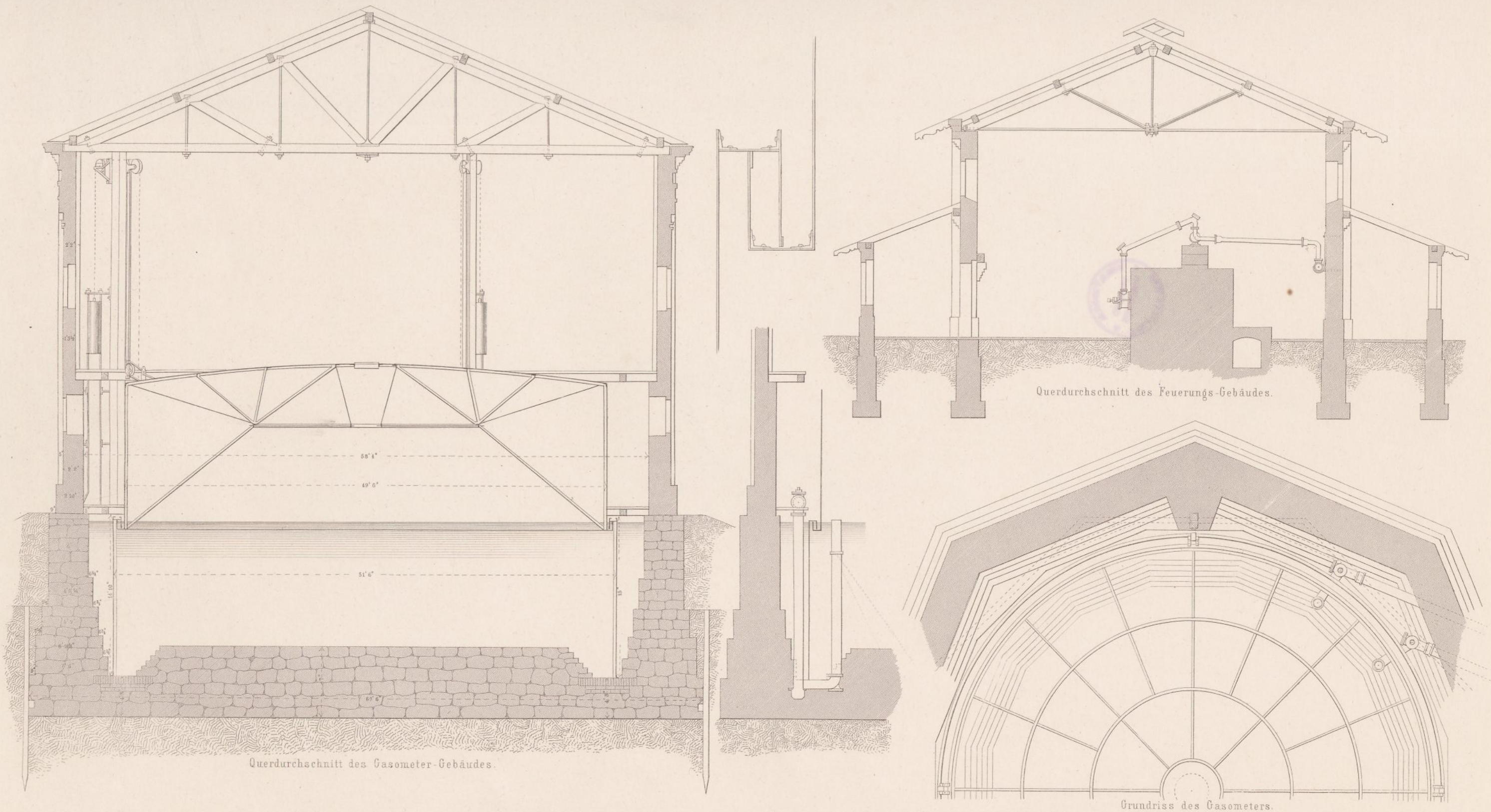

Querdurchschnitt des Gasometer-Gebäudes.

Querdurchschnitt des Feuerungs-Gebäudes.

Grundriss des Gasometers.

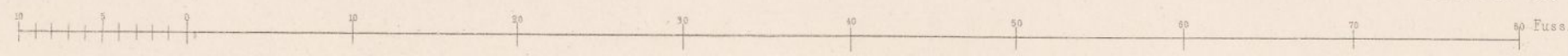

Kohlen-Schuppen.

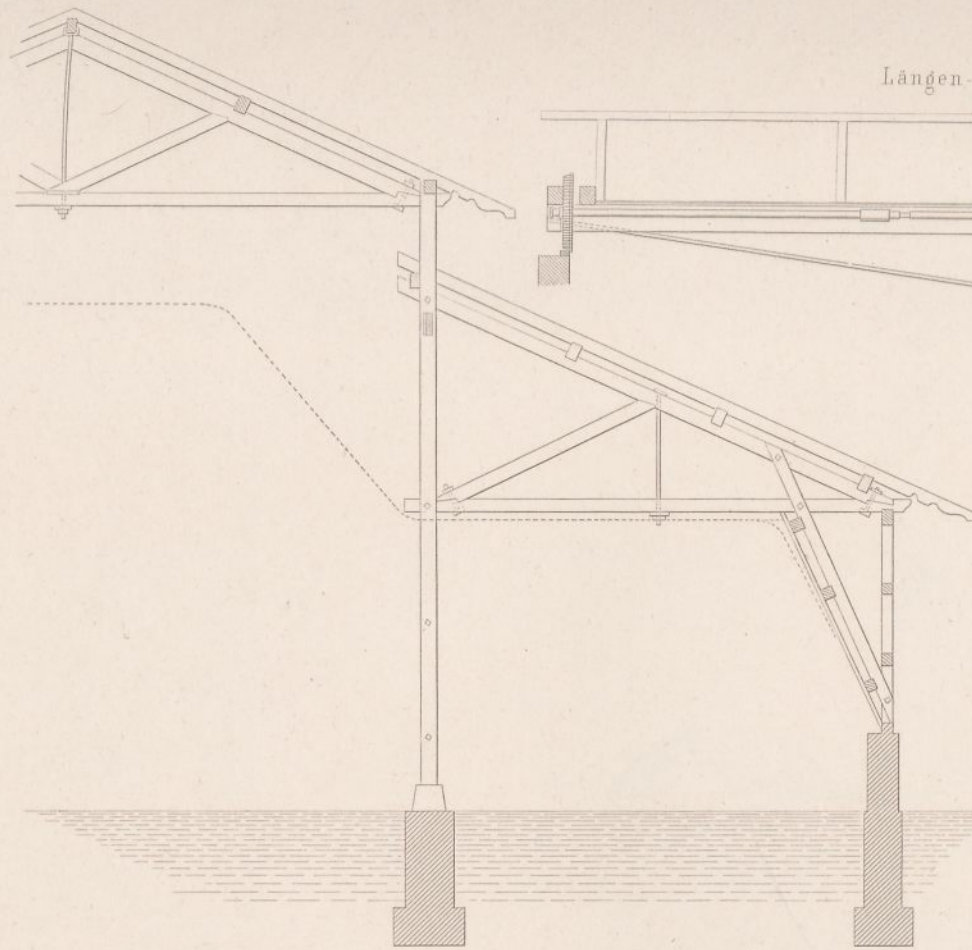
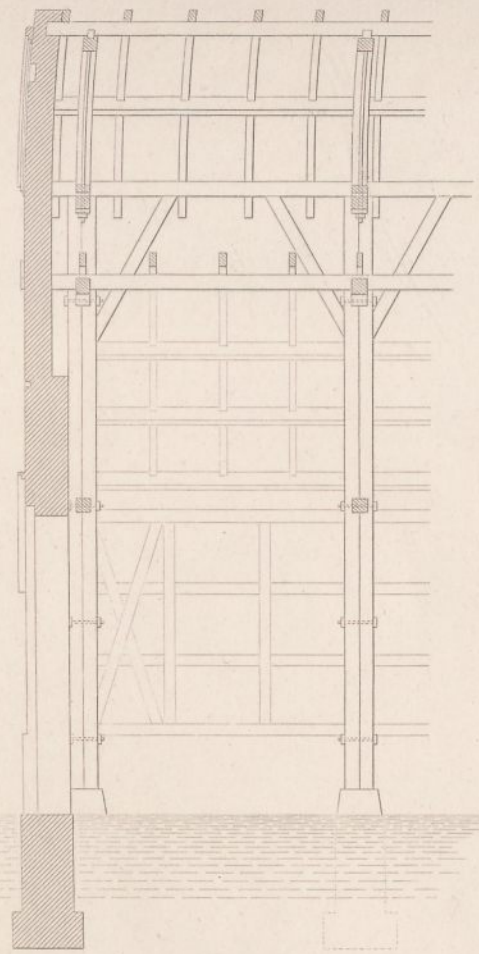

Längen-Durchschnitt.

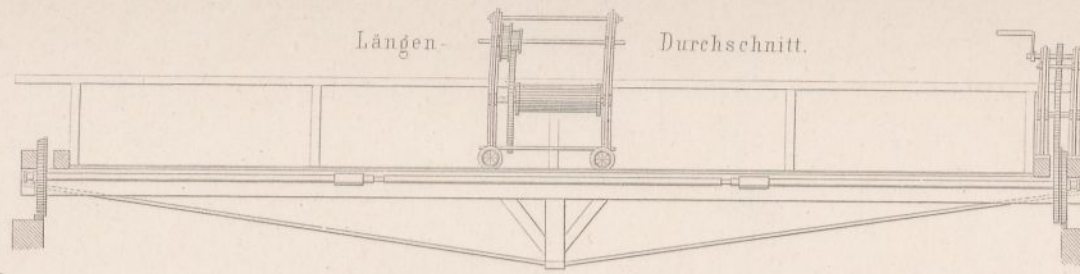

Windevorrichtung.

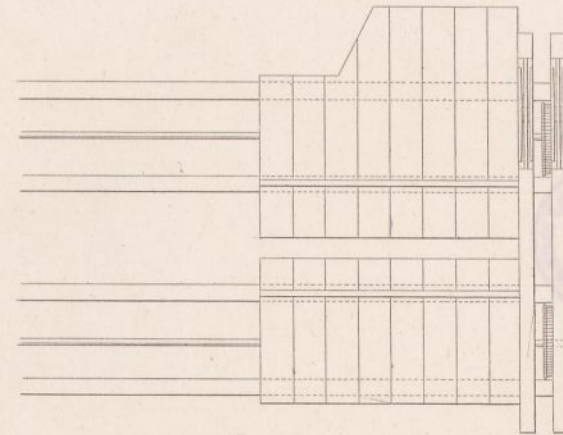

Grundriss.



Reinigungs-Gebäude.

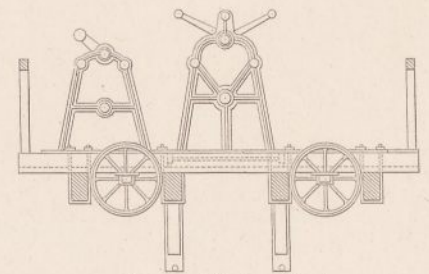
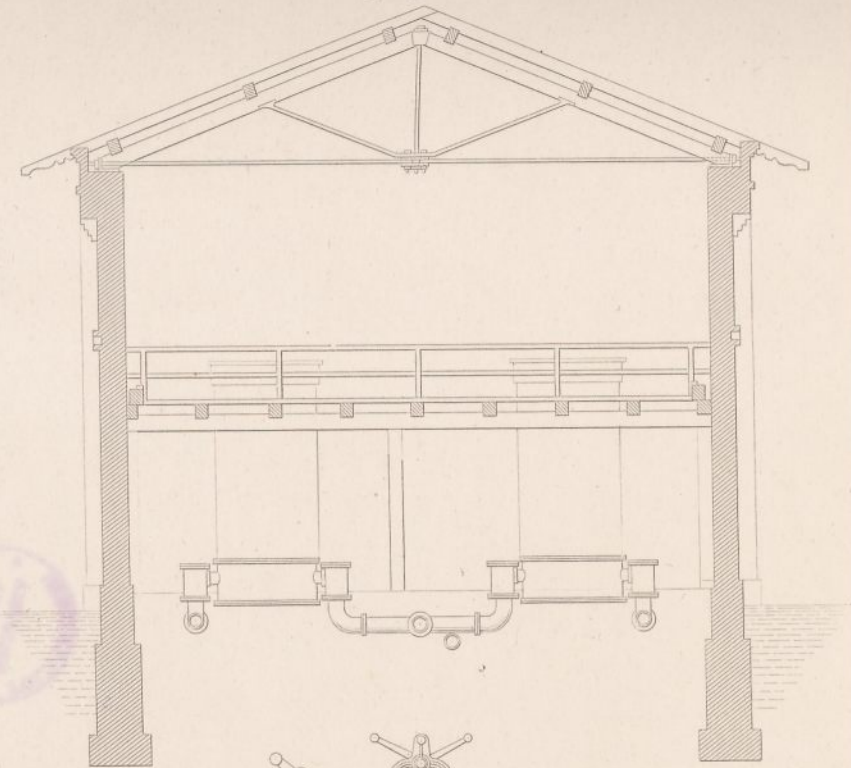

Querprofil der Winde.

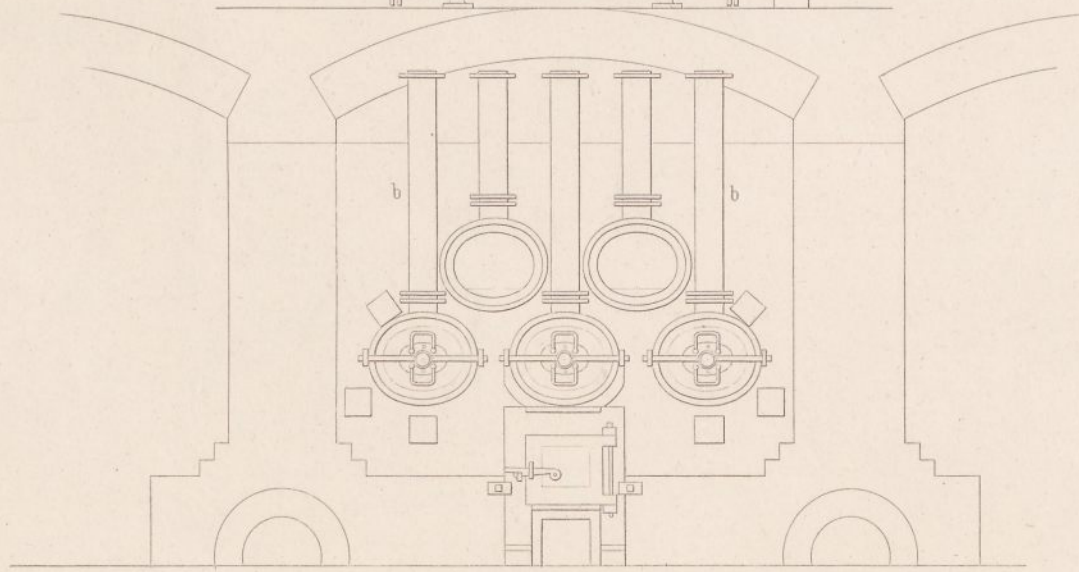
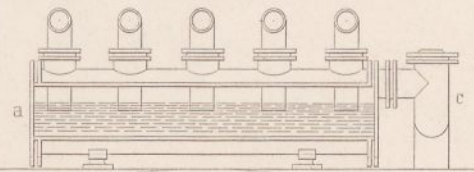

Vorder-Ansicht eines Ofens.

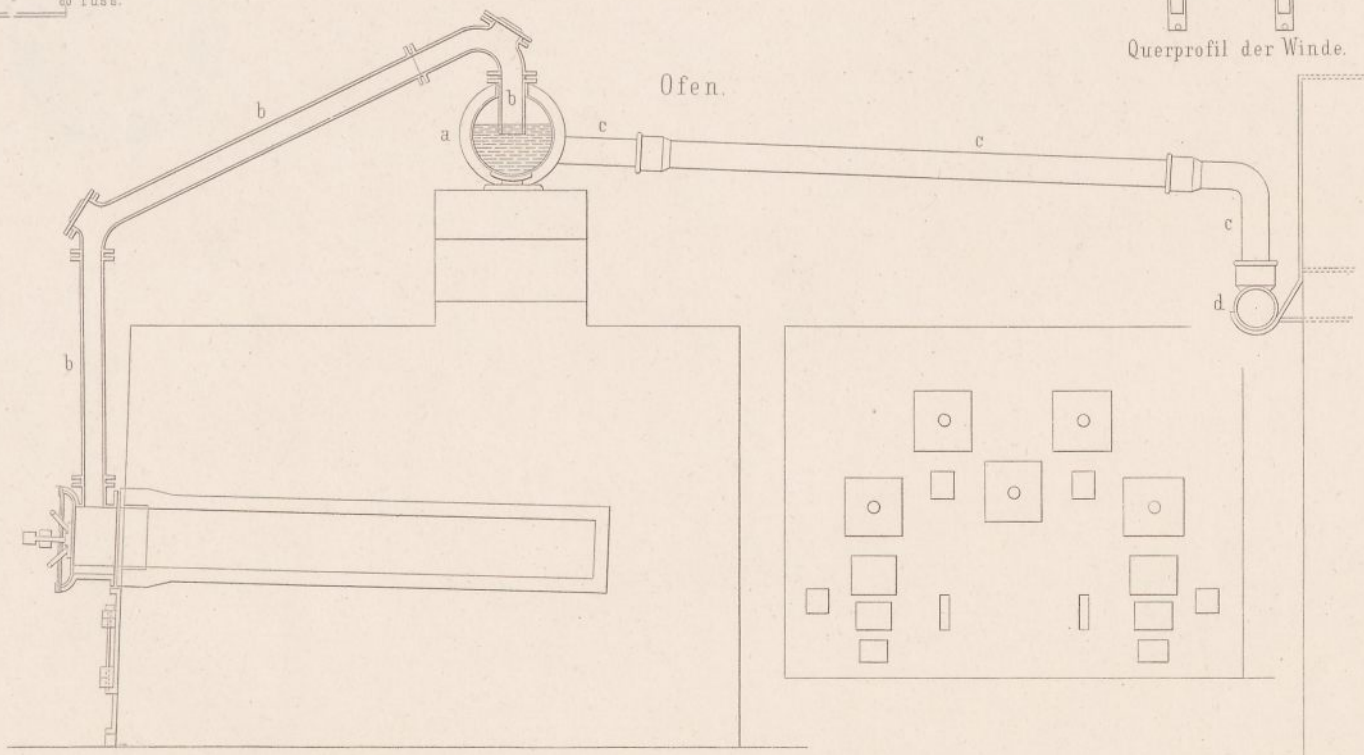

Ofen.

Längendurchschnitt.

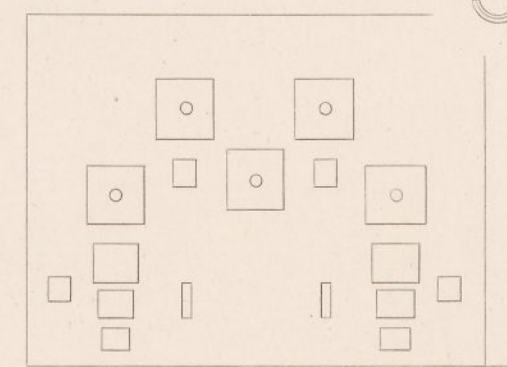

Hintere-Ansicht.

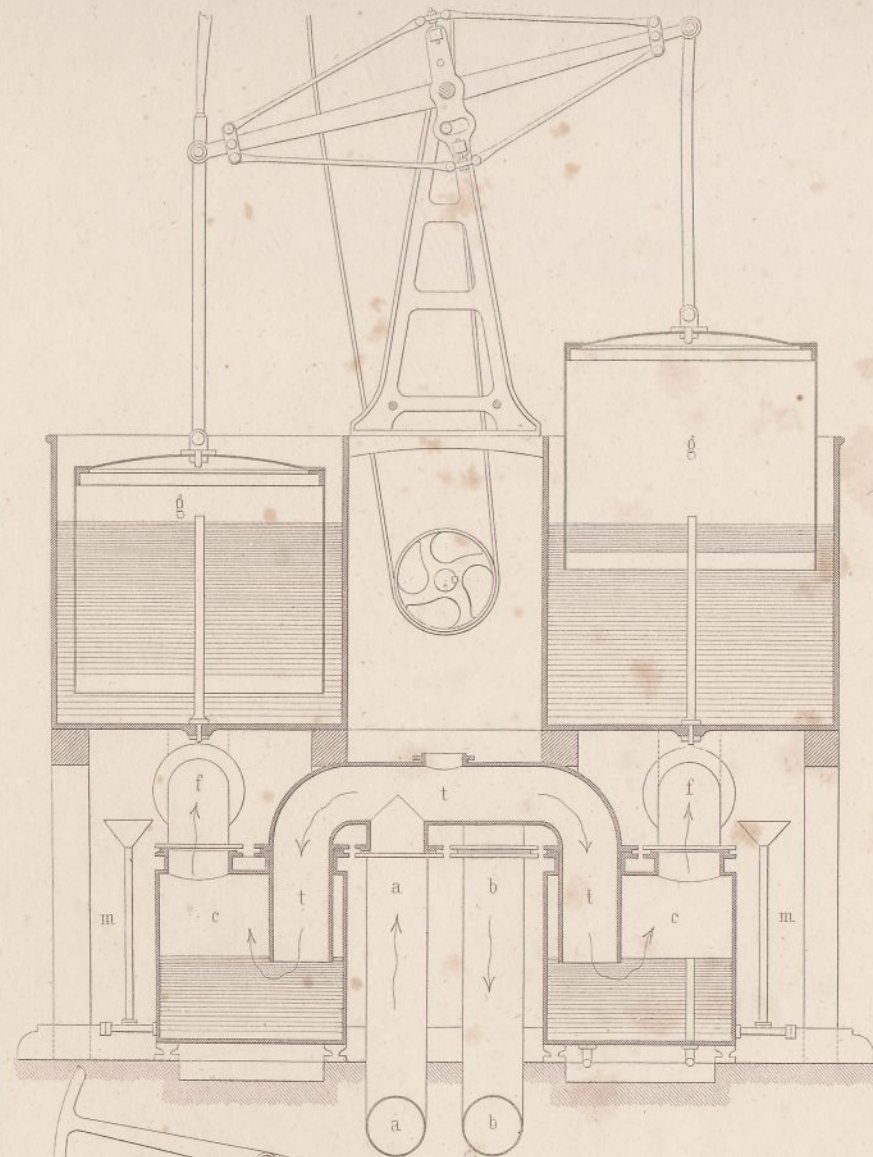

Gas-Pumpe.

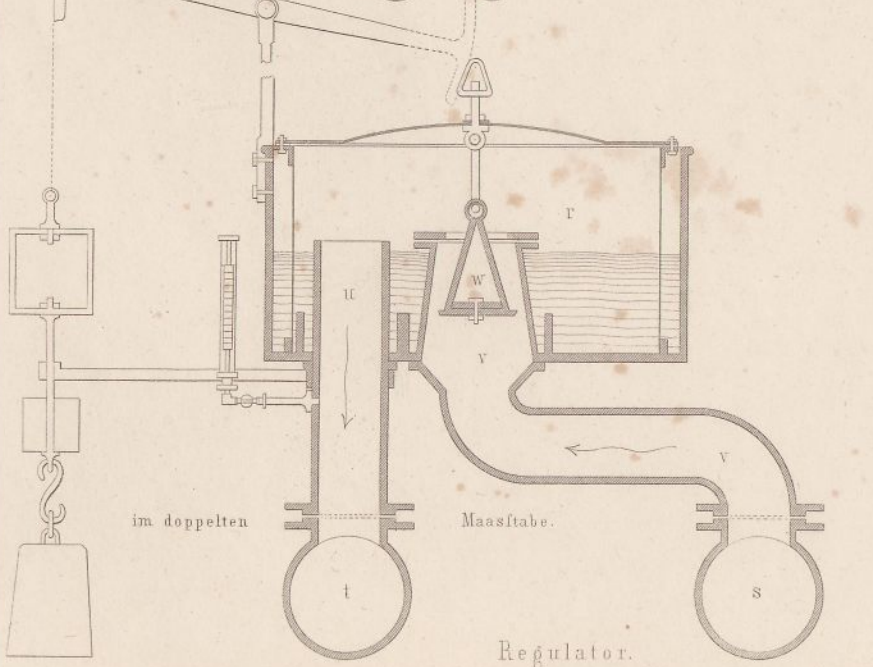

im doppelten

Maasstabe.

Regulator.

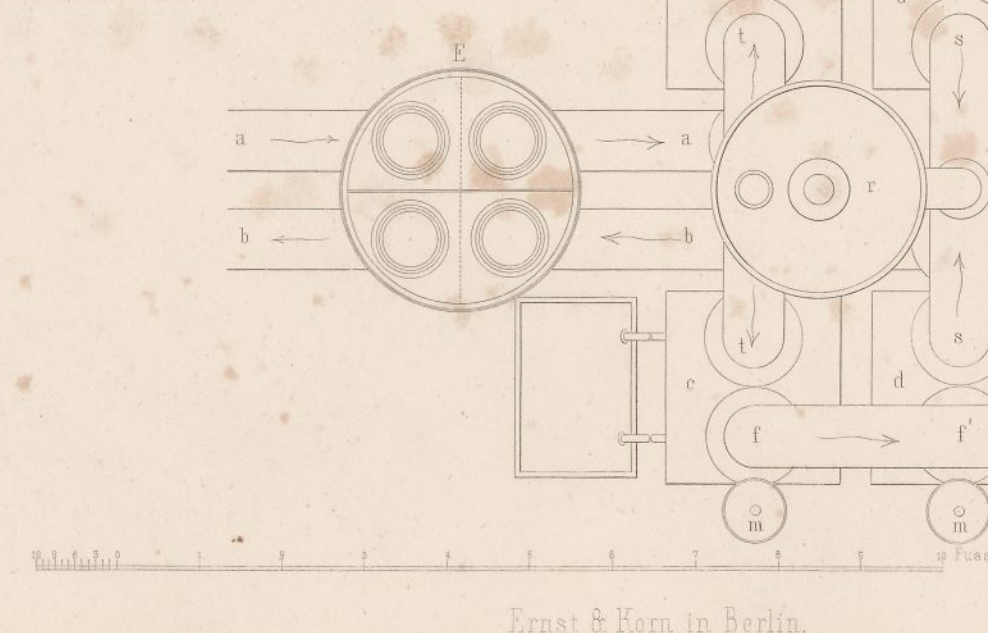
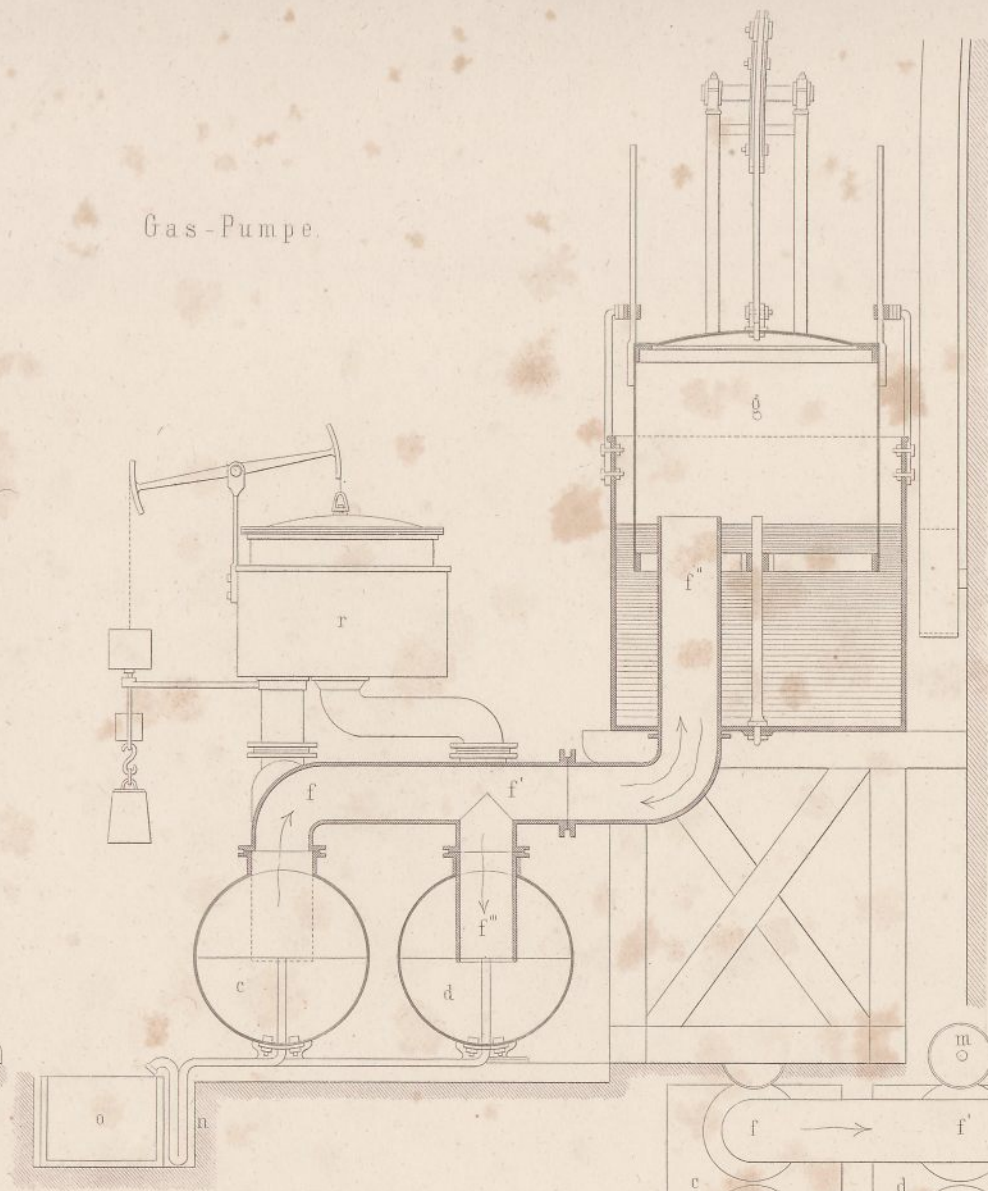

Ernst & Korn in Berlin.

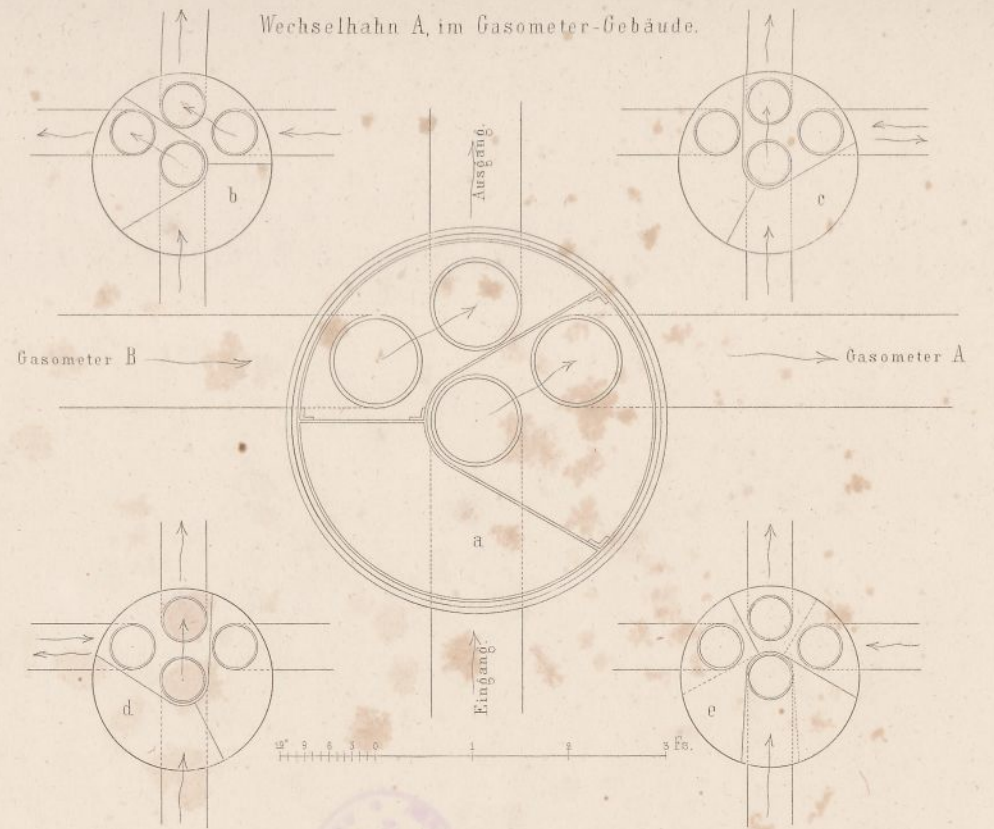

Wechselhahn A, im Gasometer-Gebäude.

Gasometer B

Gasometer A

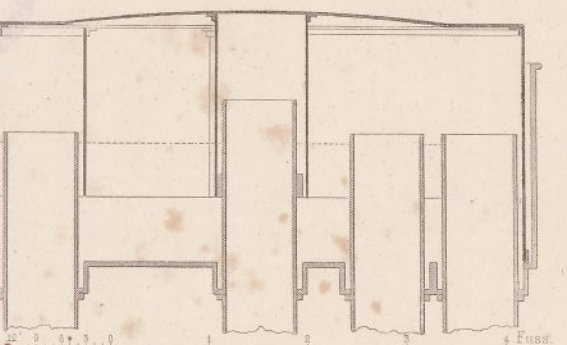

Wechselhahn G, im Reinigungs-Gebäude.

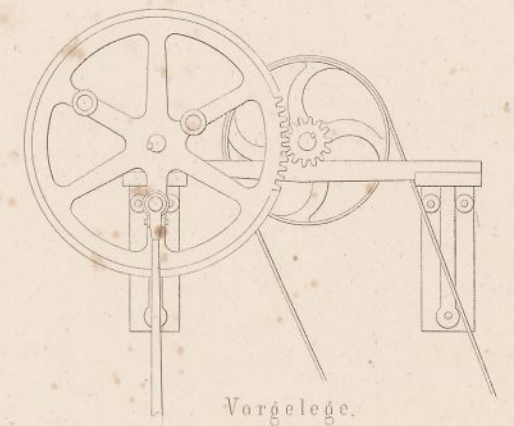

Vorgelege.

Eisenbahnwagen-Bau-Werkstatt von F. A. Pflug in Berlin.

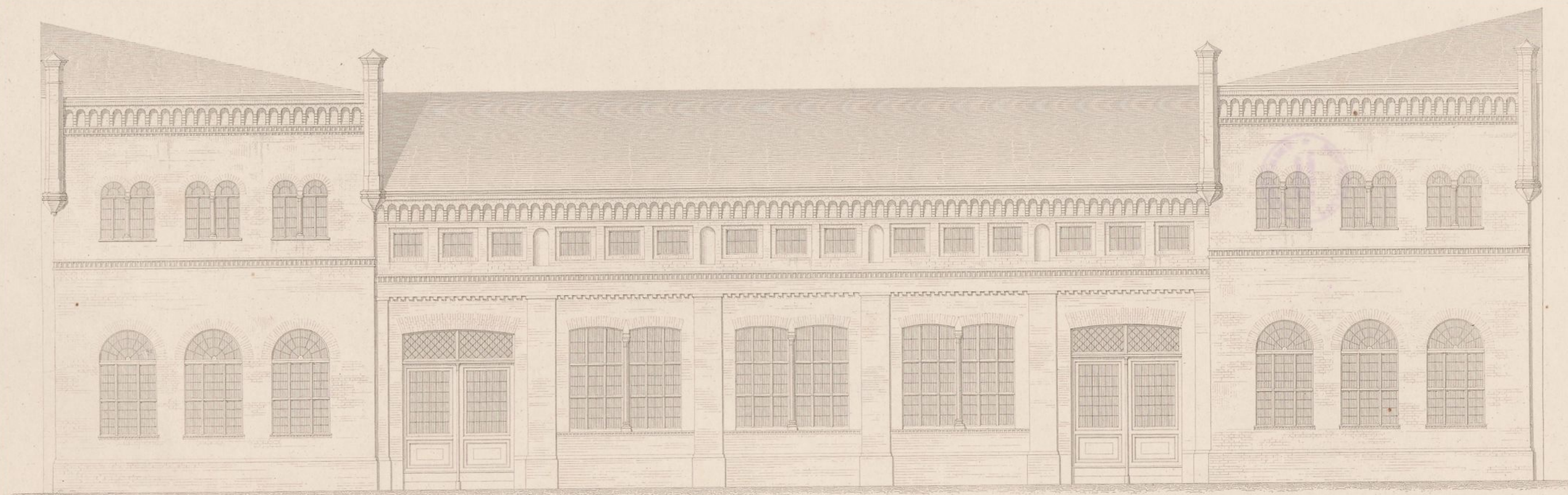

Vorder-Ansicht.

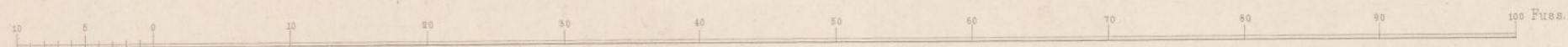

Ernst & Korn in Berlin.



Eisenbahn Wagenbau Werkstatt des Herrn Pflug zu Berlin.

Profil nach A B.

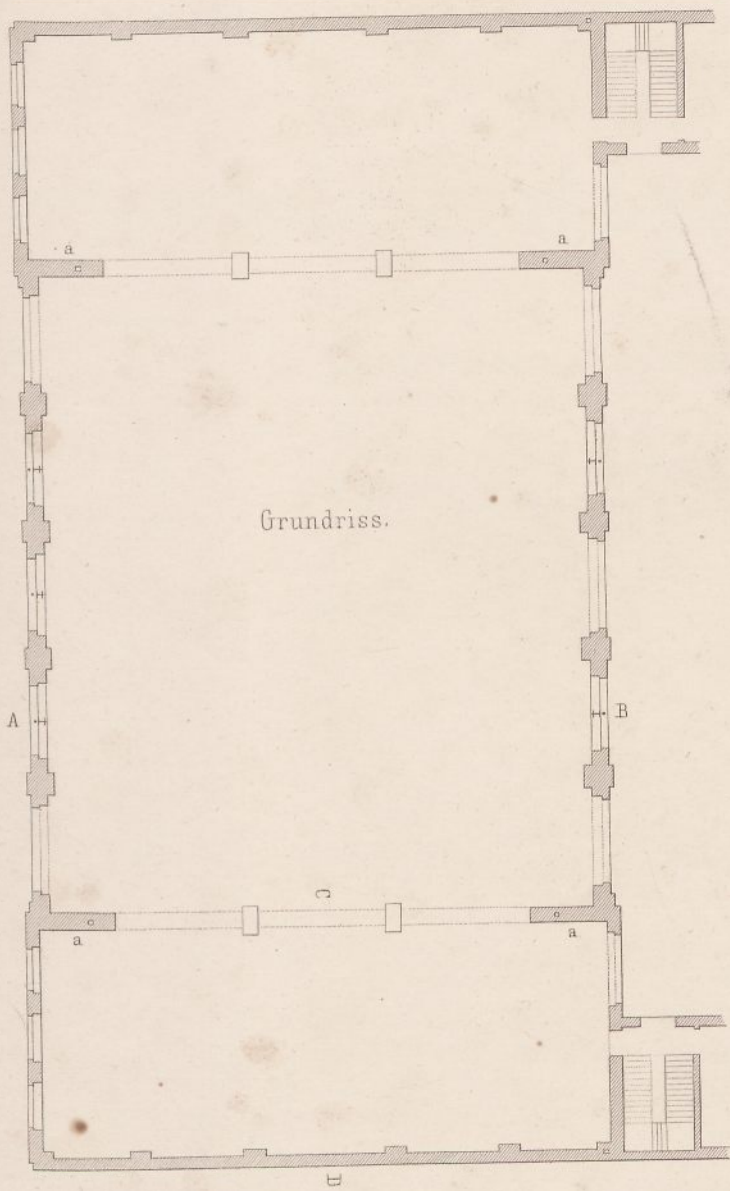
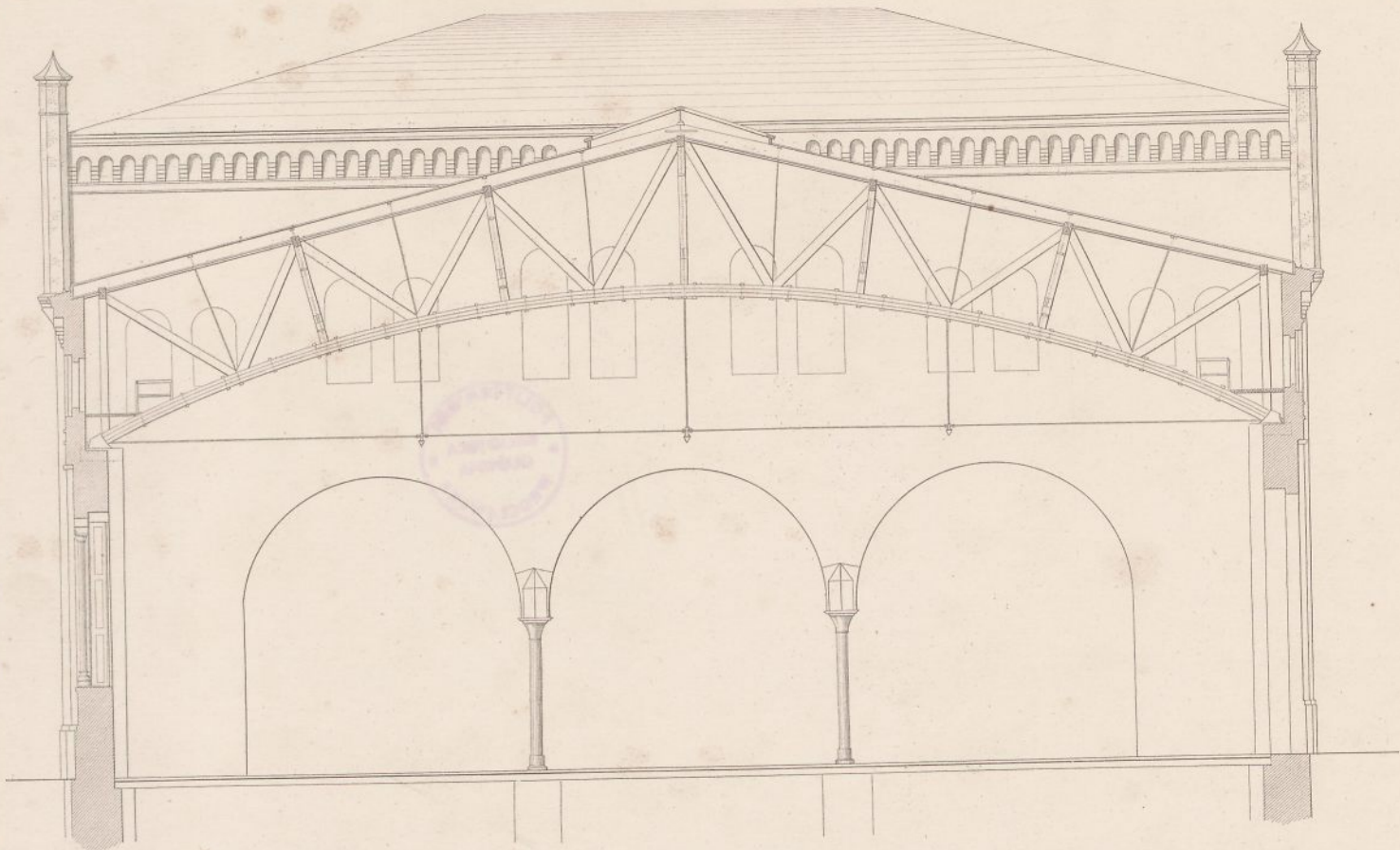

Profil nach C D.

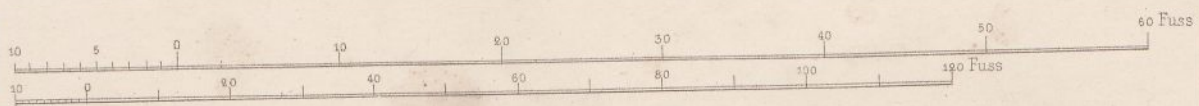
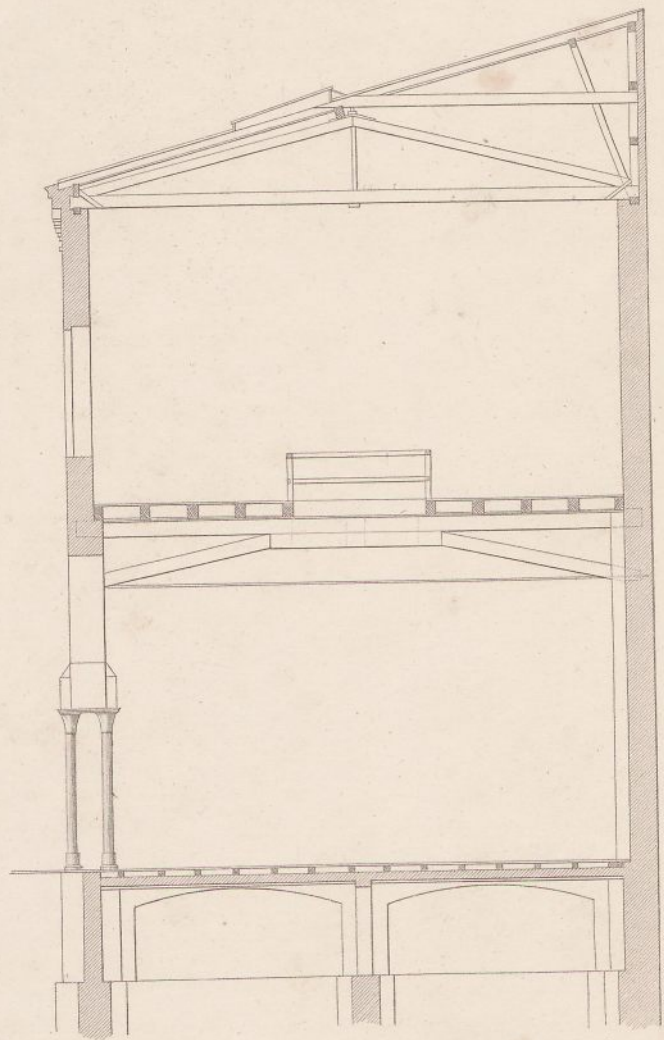

Vorder - Ansicht

Vorder - Verband.

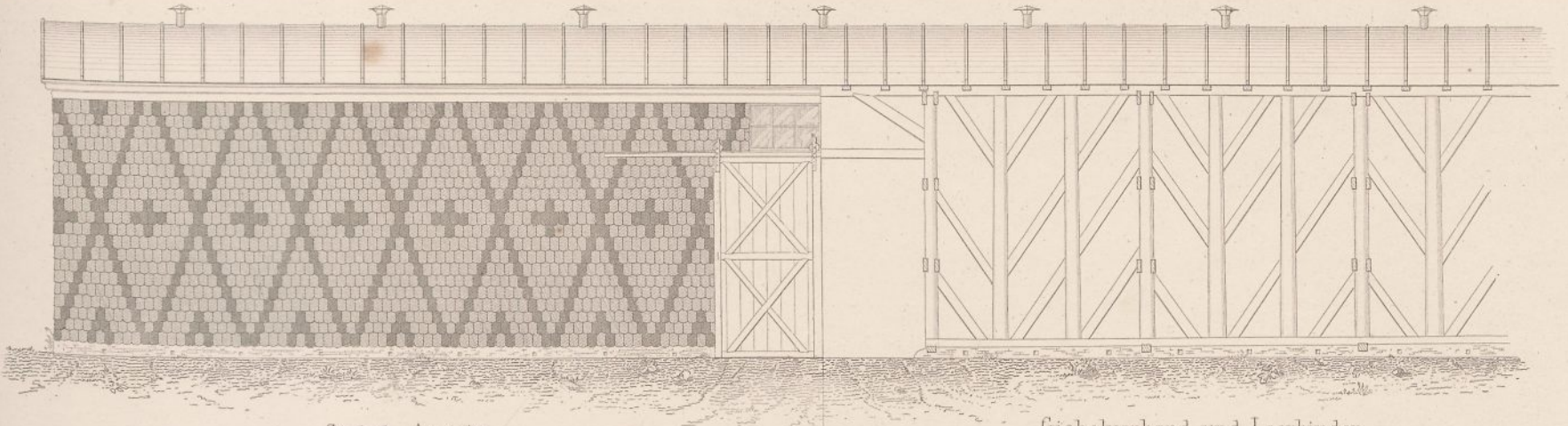

Giebel - Ansicht.

Giebelverband und Leerbinder.

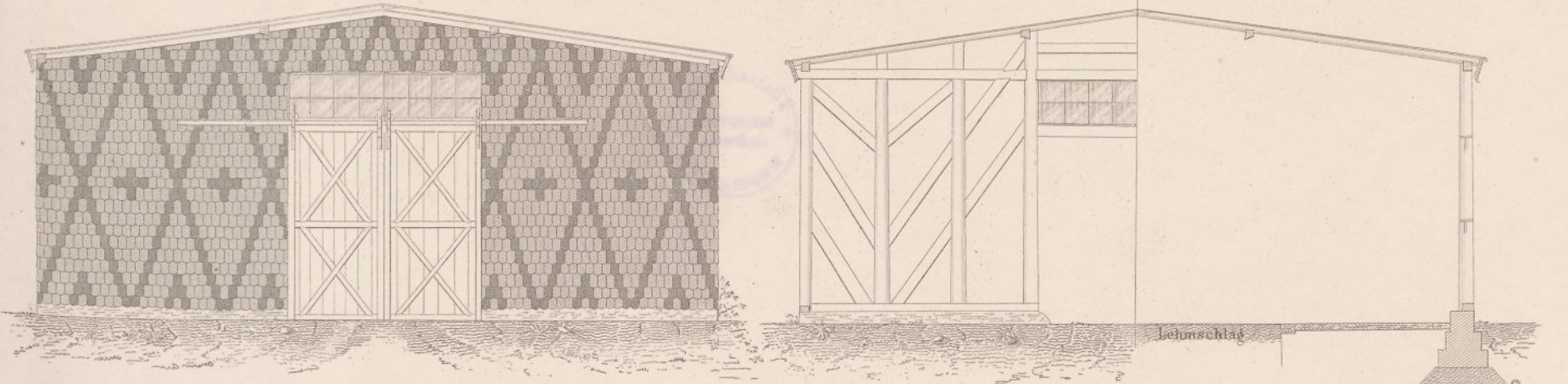

Längendurchschnitt durch die Mitte.

Hauptbinder.

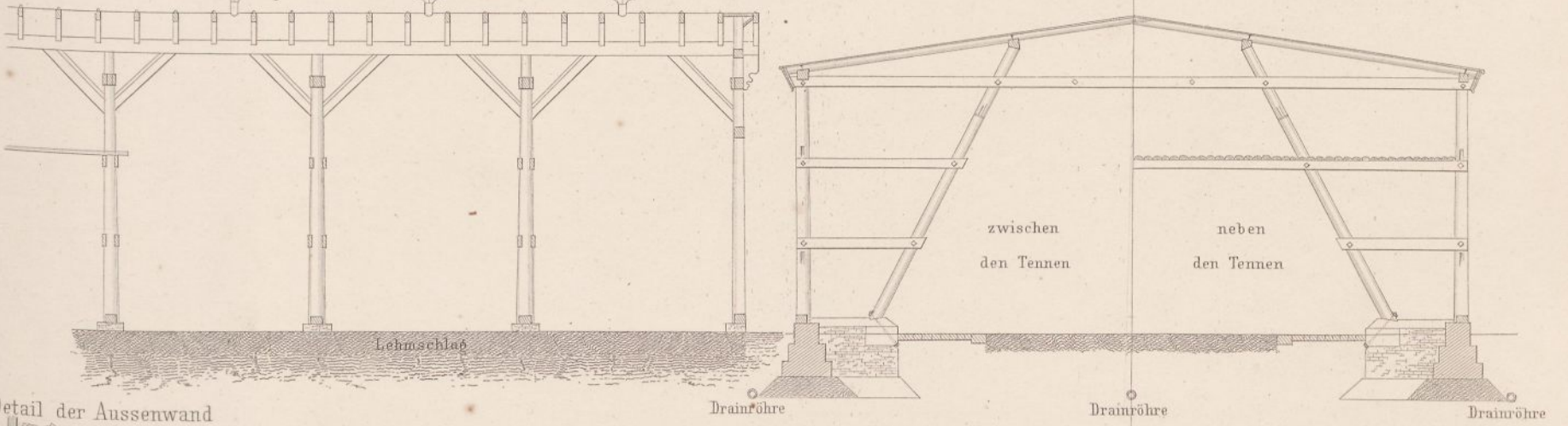

Detail der Aussenwand

Grundriss

Detail der Aussenwand am Dache

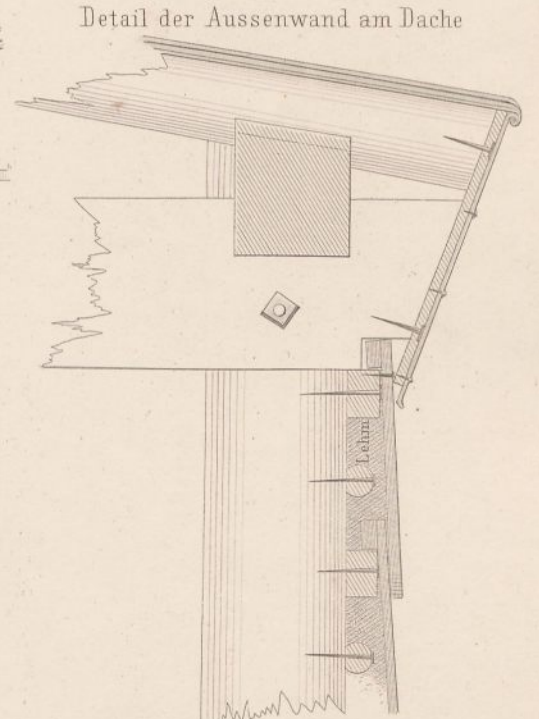
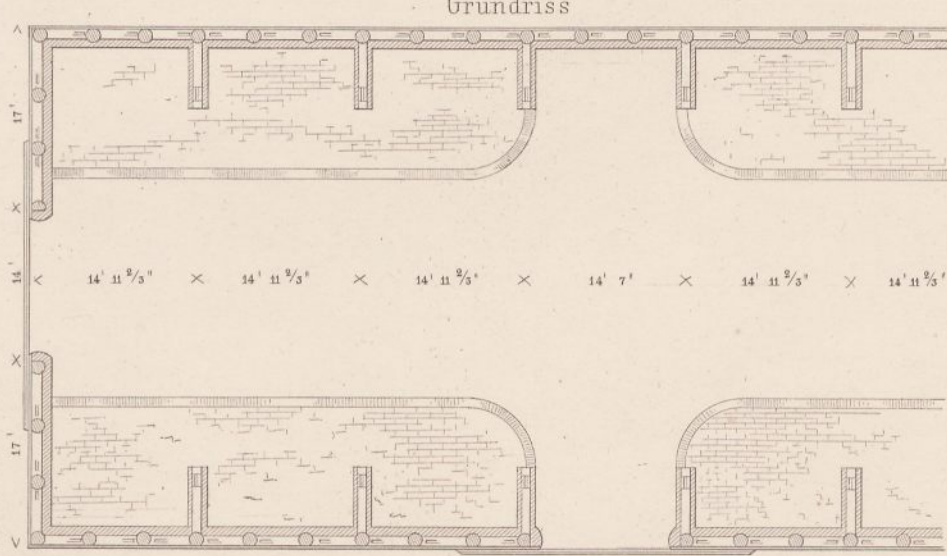
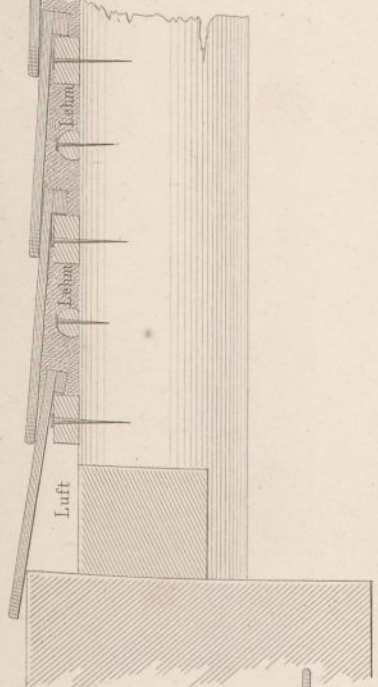

10 5 0 10 20 30 40 50 Fuss

Details vom

Thorweg.

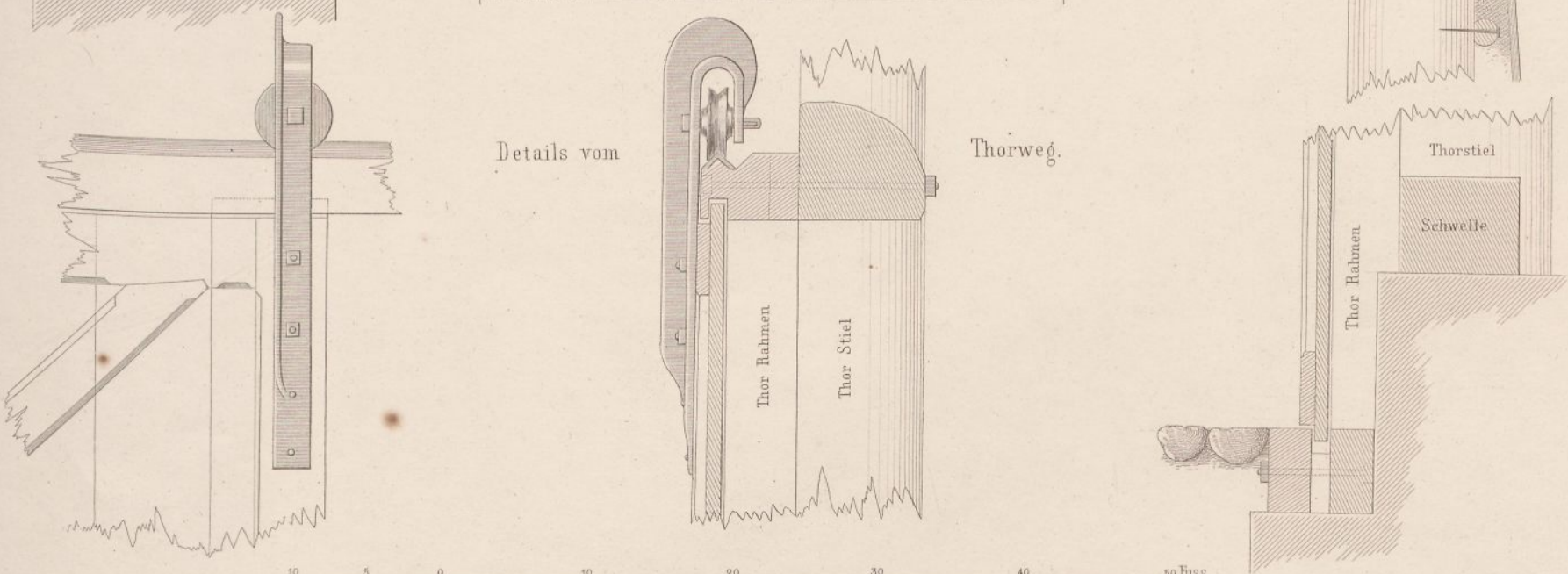

10 5 0 10 20 30 40 50 Fuss

Dachverband vom Strafsburger Eisenbahnhofe zu Paris.

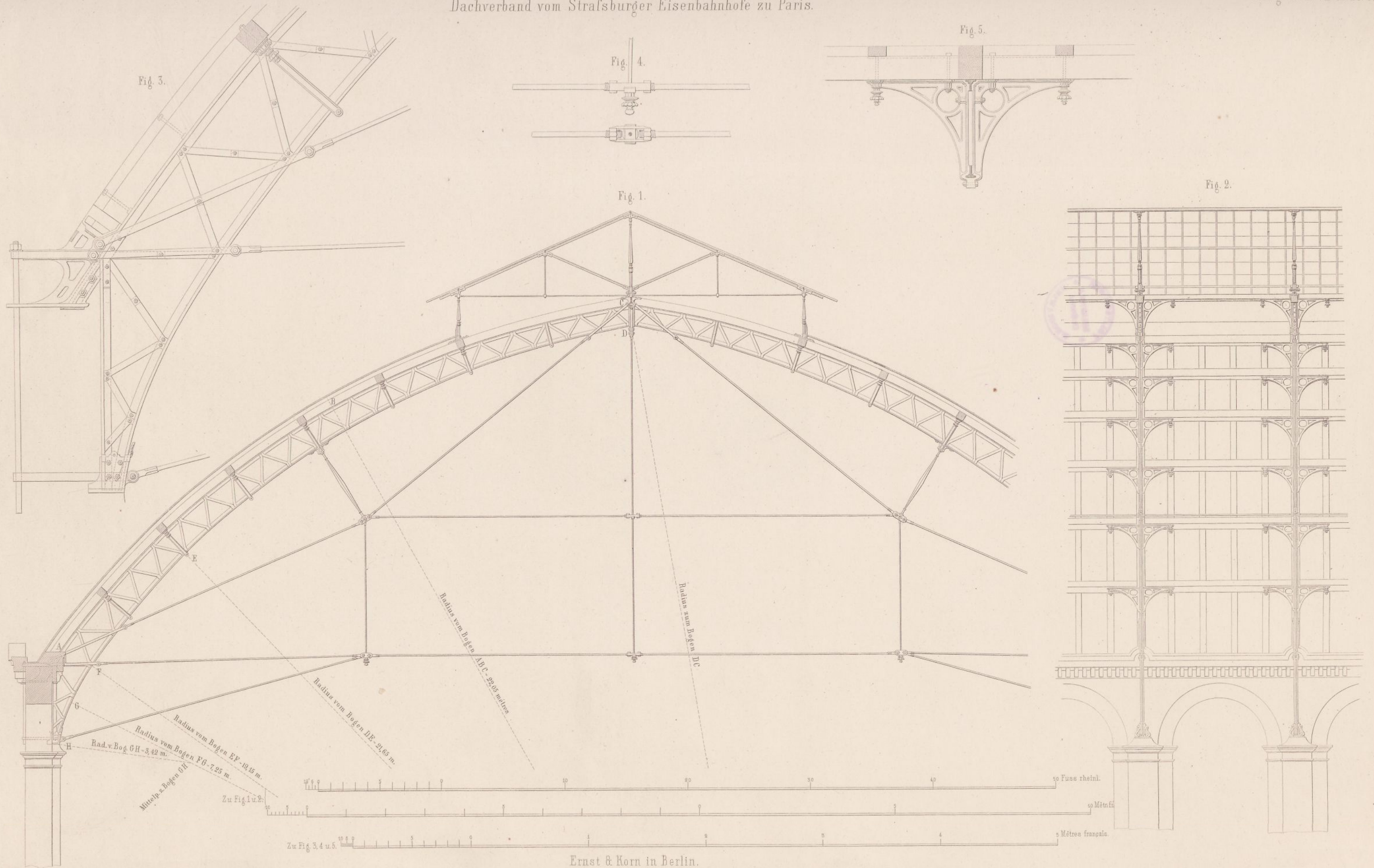

Dachverband vom Lyoner Eisenbahnhofe zu Paris.

Fig. 1.

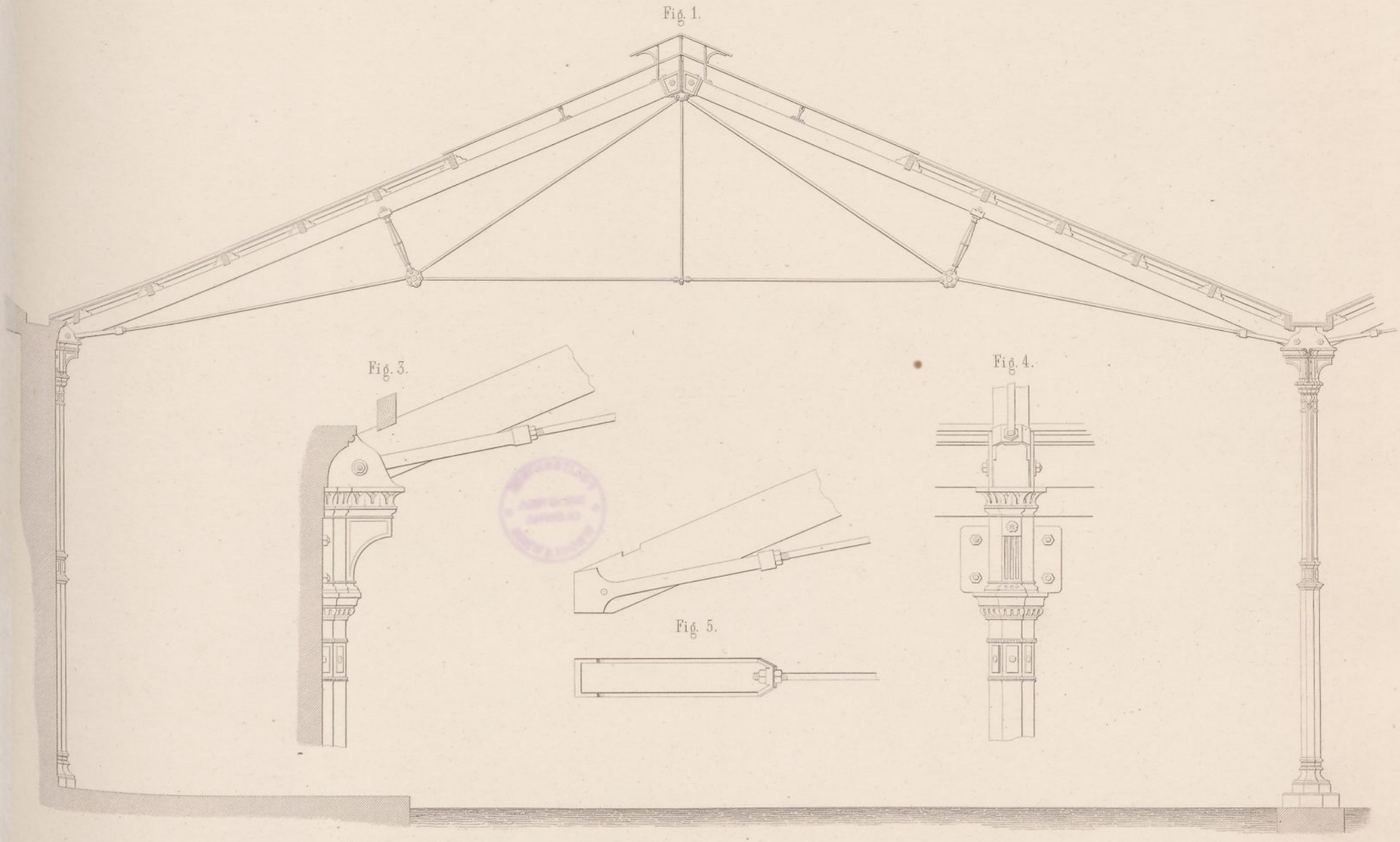

Fig. 3.

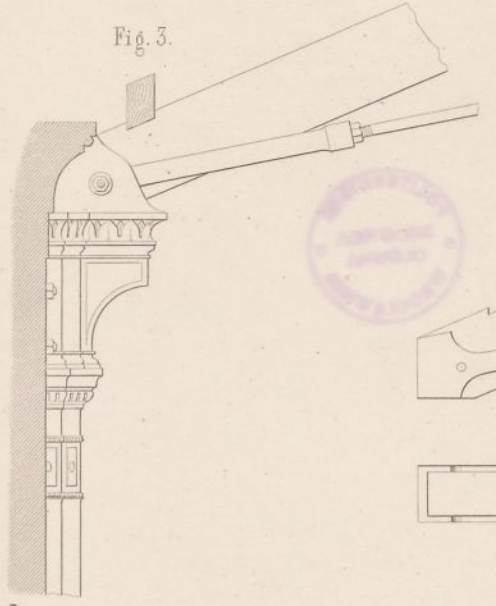

Fig. 4.

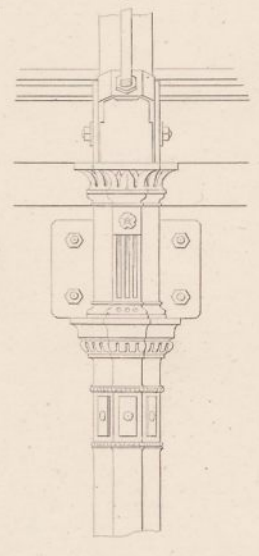

Fig. 5.

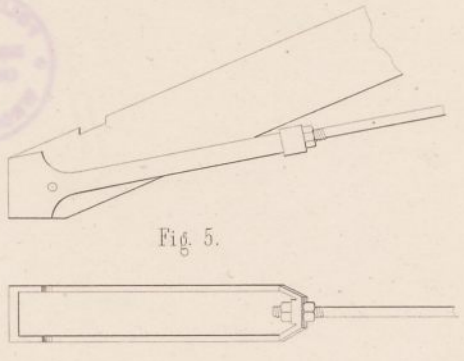

Fig. 7.

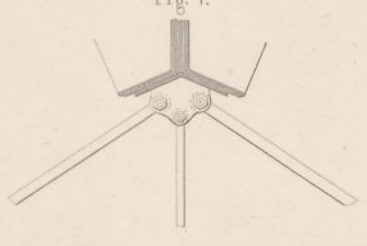

Fig. 6.

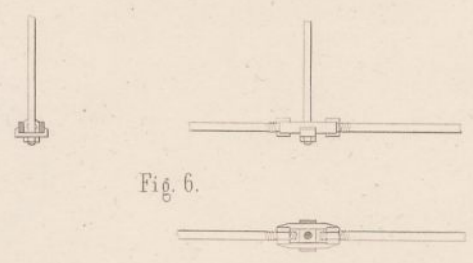

Fig. 2.

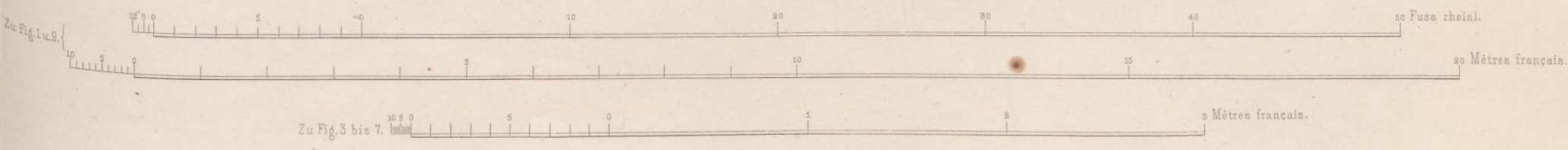
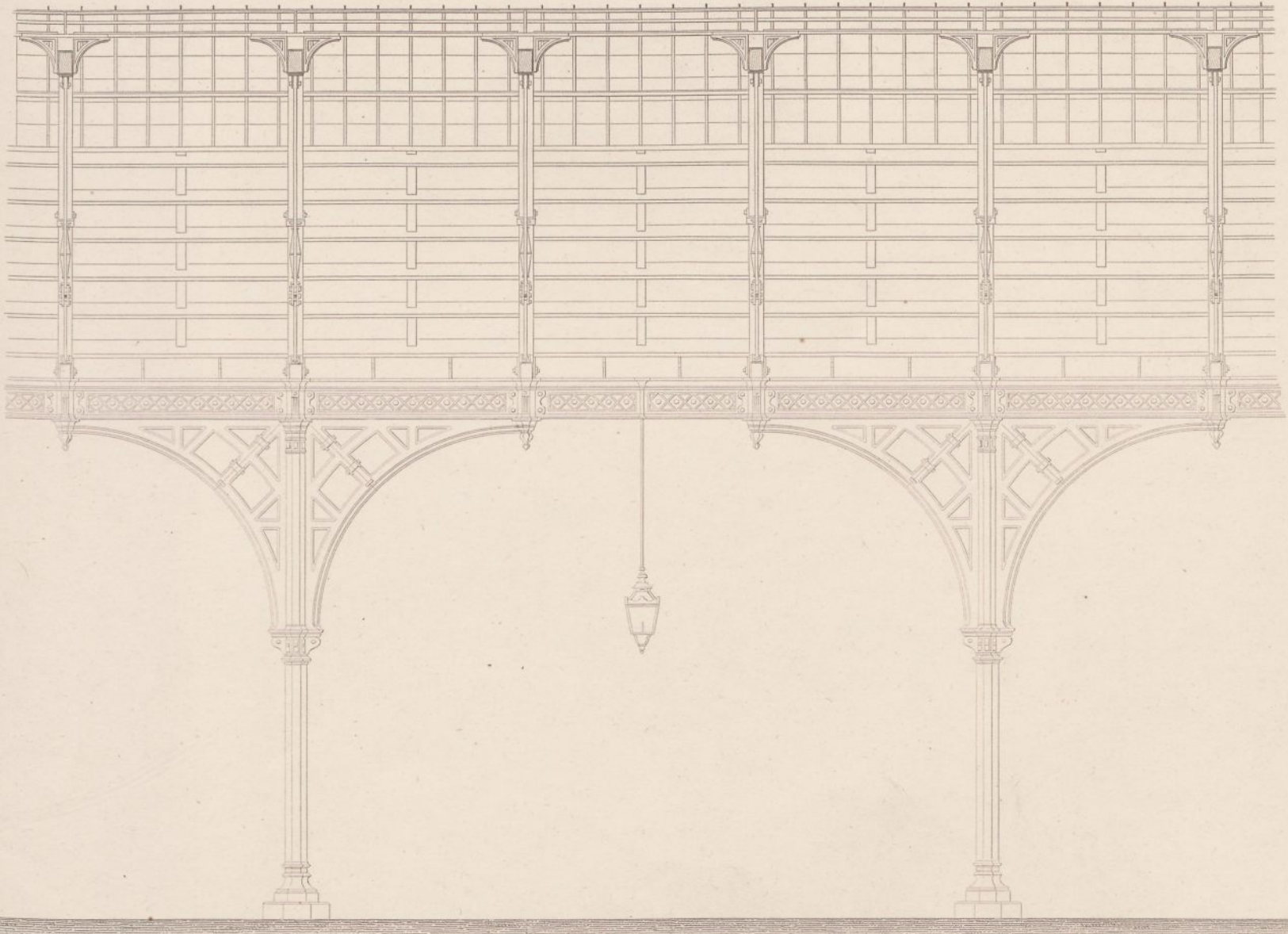

Fig. 1. Längendurchschnitt der Betriebsarhe.

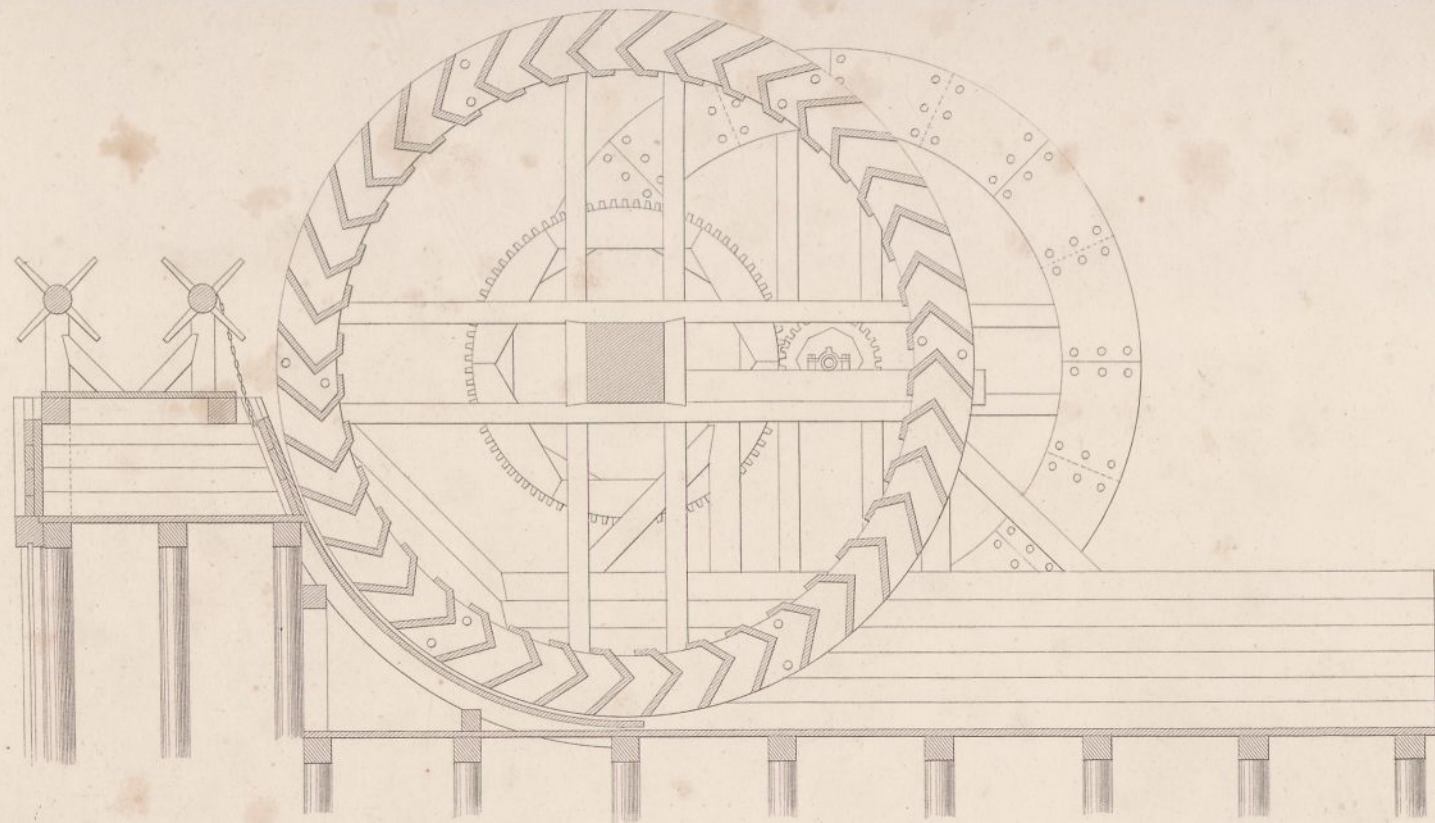

Fig. 2. Grundriss der Betriebsarhe.

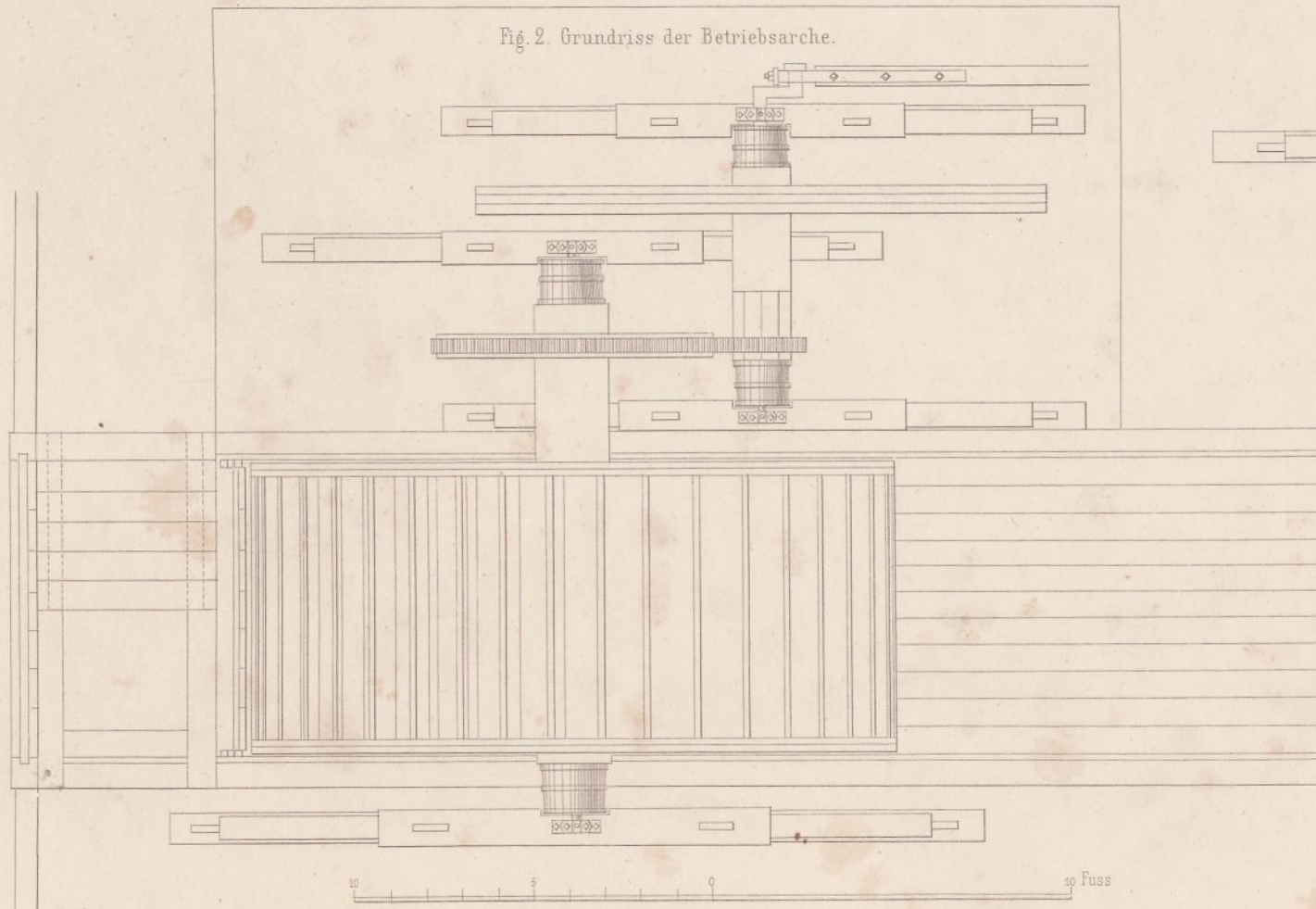

Fig. 3. Querdurchschnitt der Betriebsarhe.

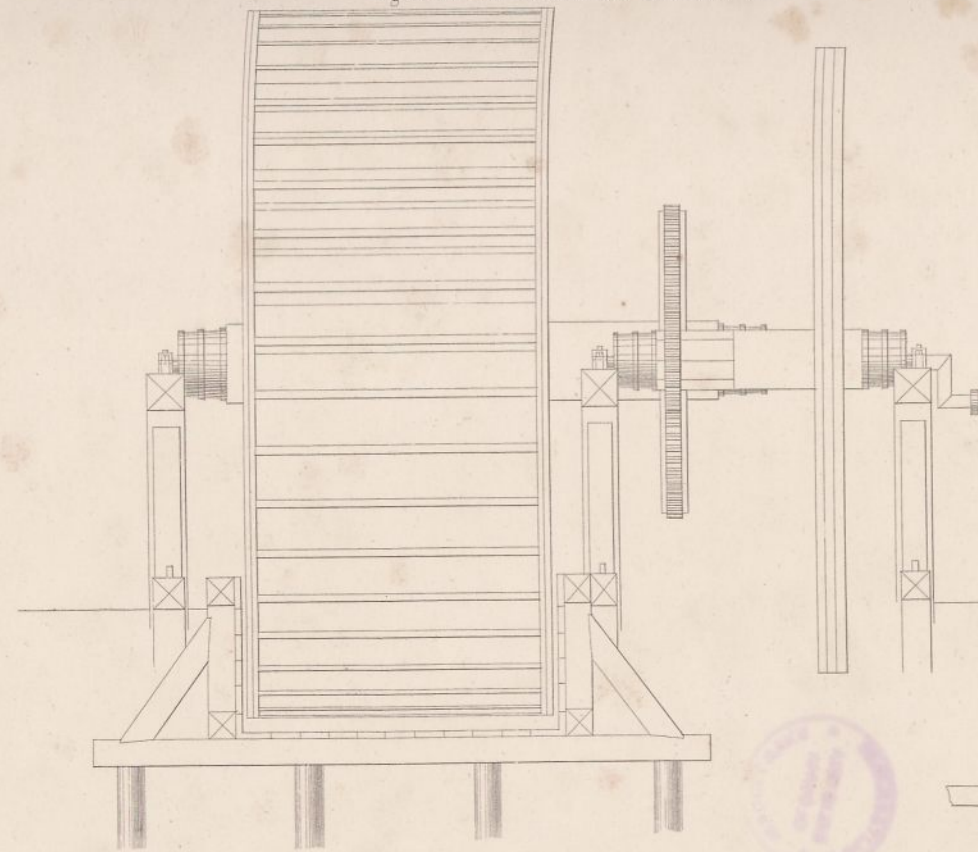

Fig. 4. Grundriss des Wendebocks.

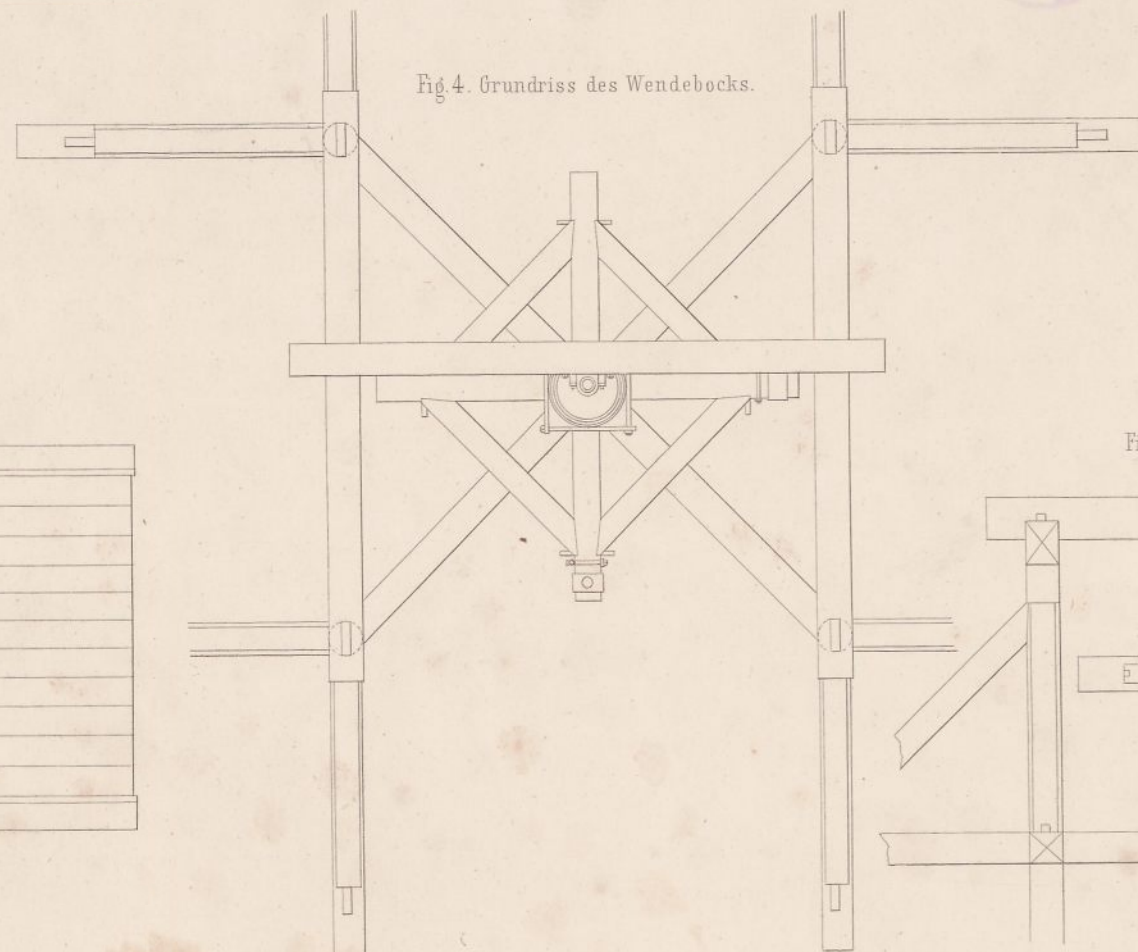

Fig. 5. Ansicht des Wendebocks.

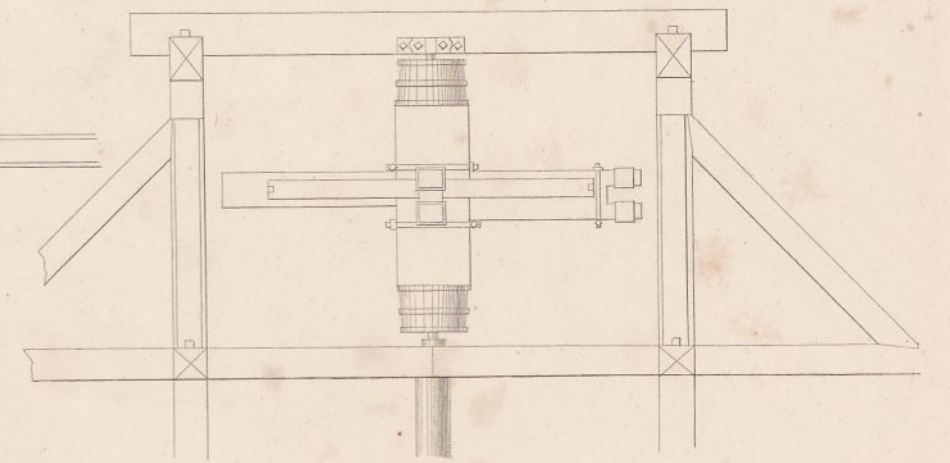

Fig. 6.

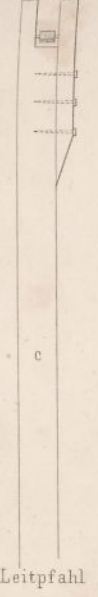

Fig. 7.

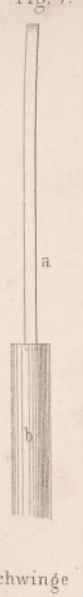

Fig. 8. Gestänge mit Leitfahl und Schwinde.

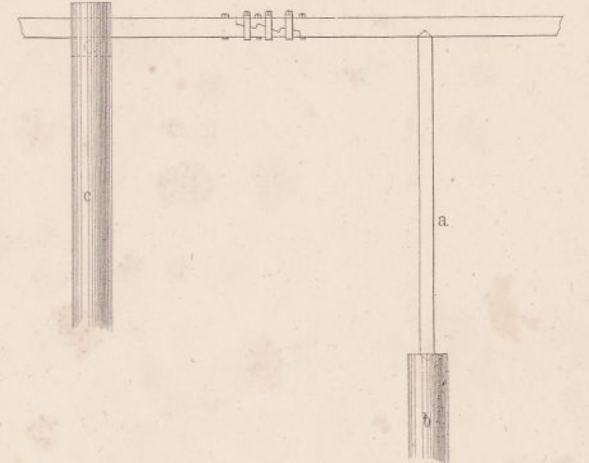

Fig. 1. Seiten-Ansicht des Pumpwerks.

Fig. 2. Vorder-Ansicht des Pumpwerks.

Fig. 3. Grundriss des Pumpwerks.

Fig. 4. Grundriss des Pumpenkastens.

Details

vom Kunstkreuz.

Ueberblattung des Gestänges.

Joch um die Gatterwelle.



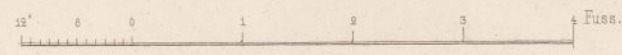
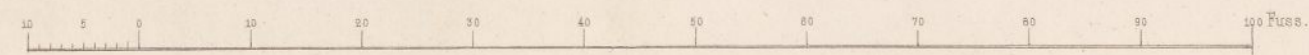
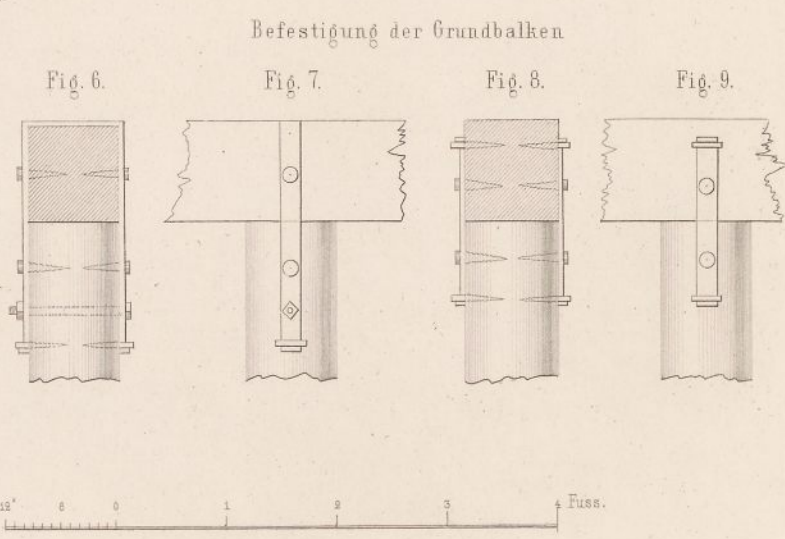
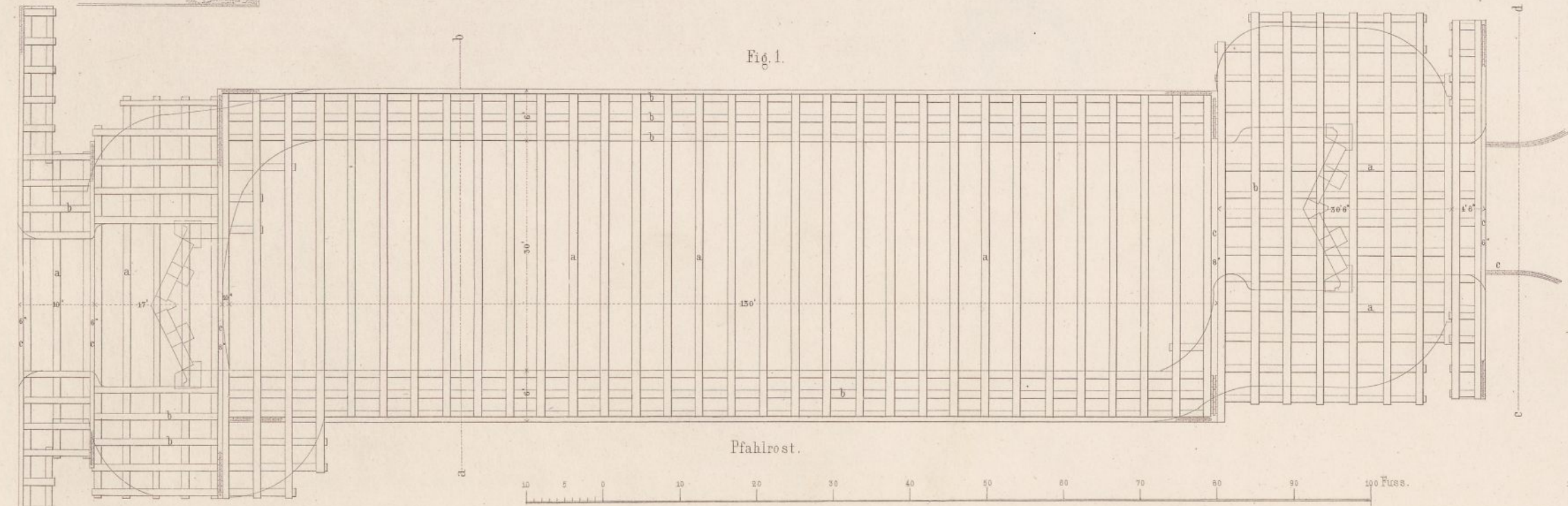
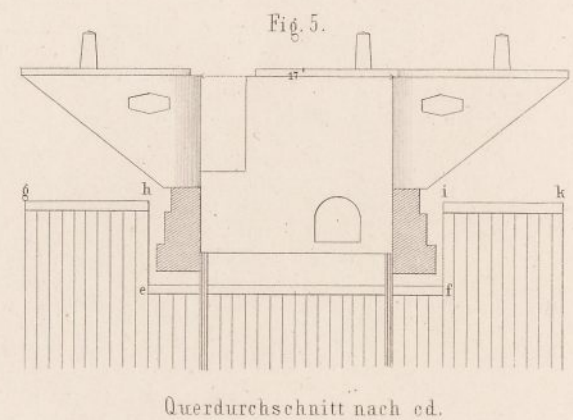
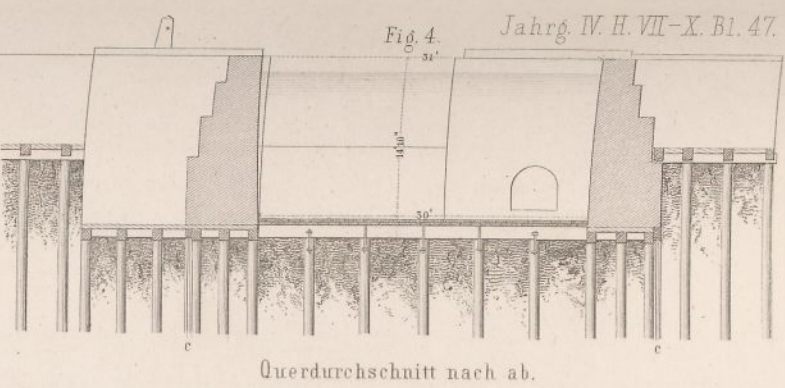
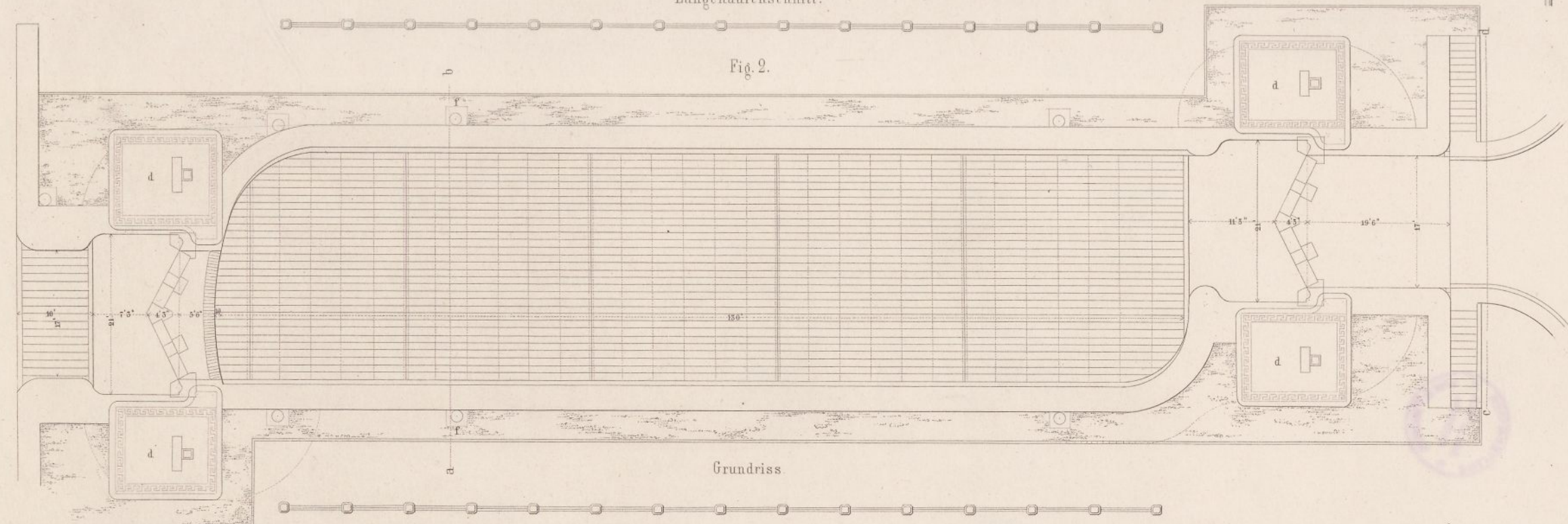
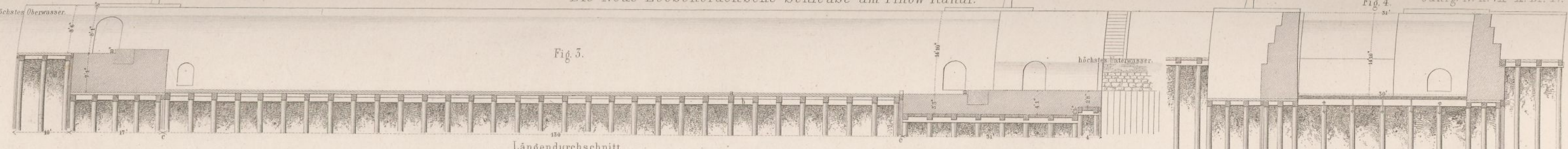

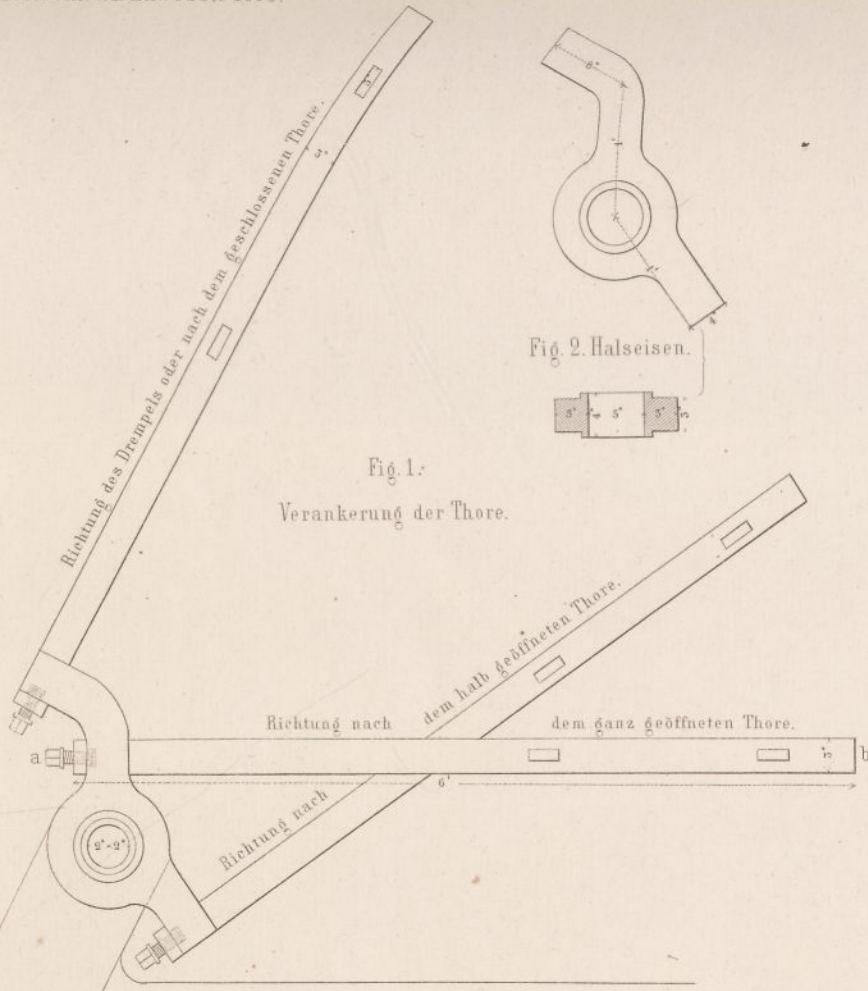

Fig. 1. Verankerung der Thore.

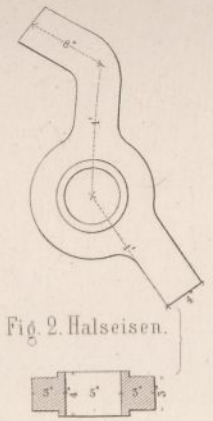

Fig. 2. Halseisen.

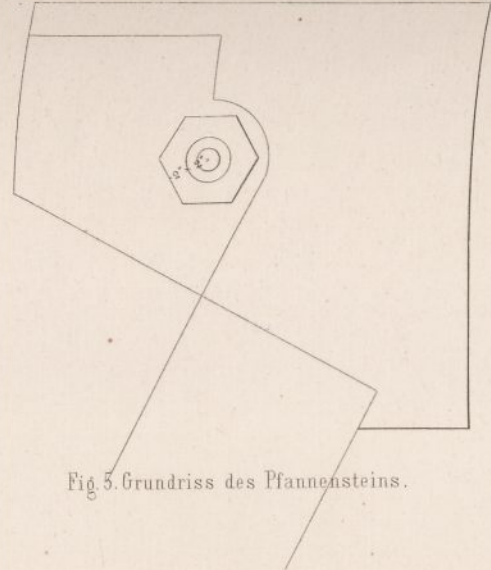

Fig. 5. Grundriss des Pfannensteins.

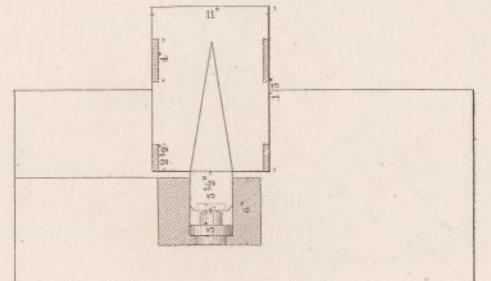

Fig. 6. Durchschnitt des Pfannensteins.

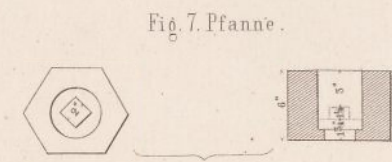

Fig. 7. Pfanne.

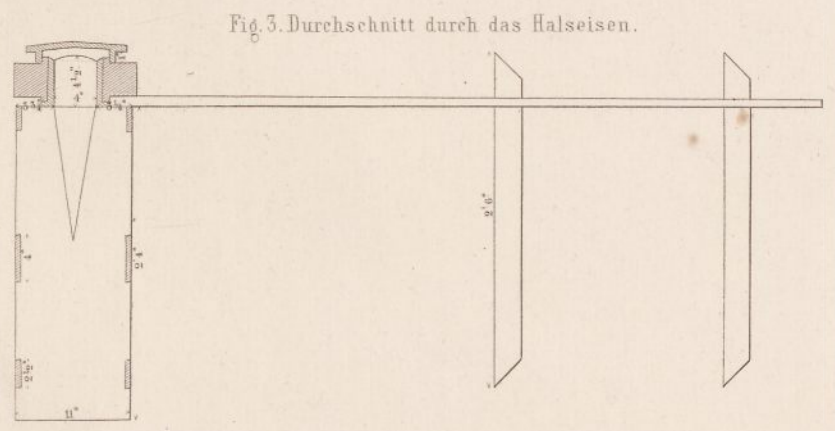

Fig. 3. Durchschnitt durch das Halseisen.

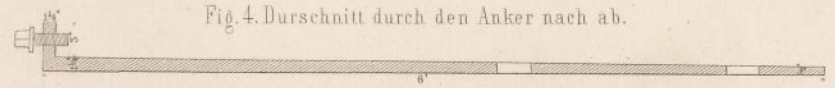

Fig. 4. Durchschnitt durch den Anker nach ab.

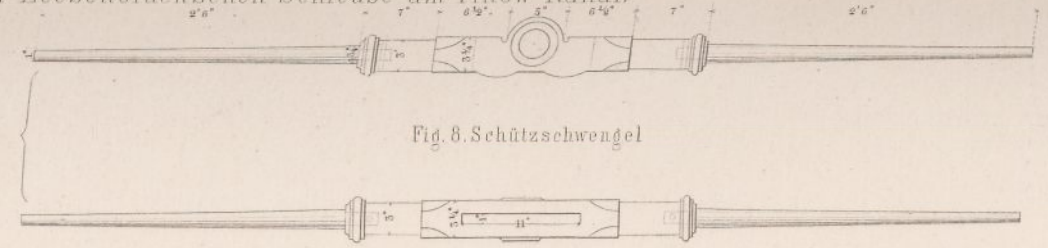

Fig. 8. Schüttschwengel.



Fig. 9. Schützdockenbolzen.

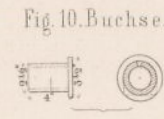

Fig. 10. Buchse.

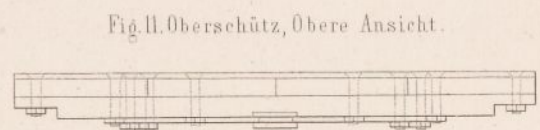

Fig. 11. Oberschütz, Obere Ansicht.

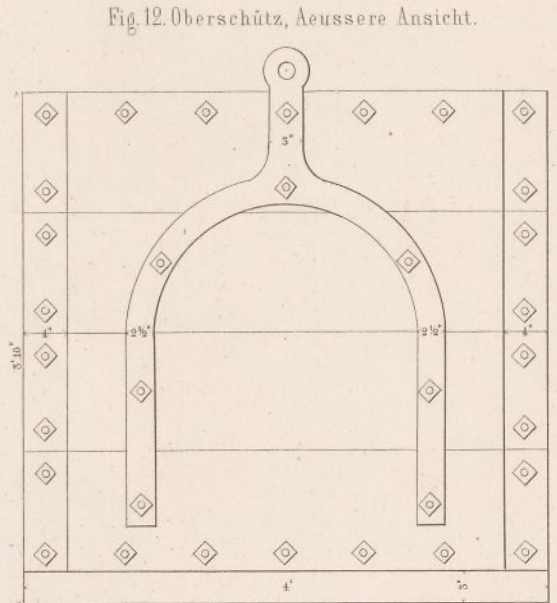

Fig. 12. Oberschütz, Aeussere Ansicht.

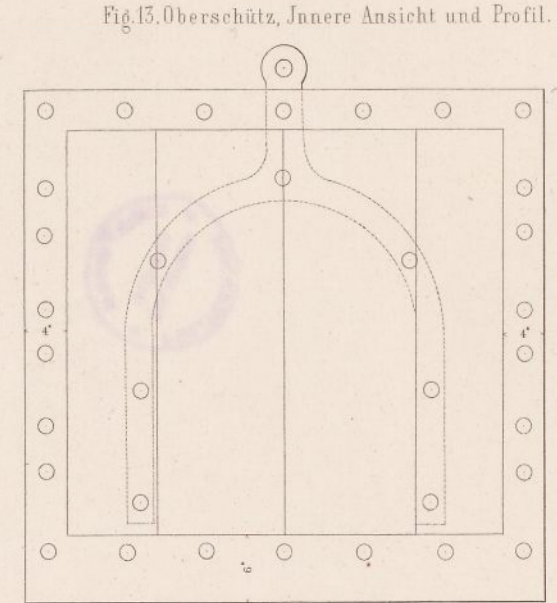

Fig. 13. Oberschütz, Innere Ansicht und Profil.

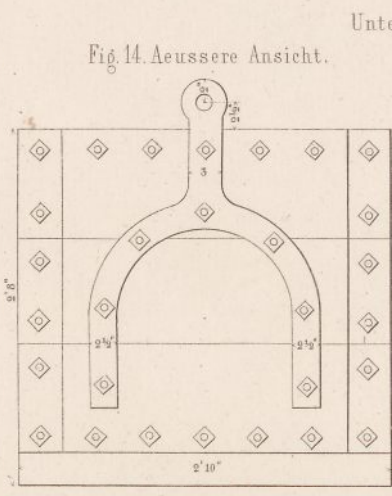

Fig. 14. Aeussere Ansicht.

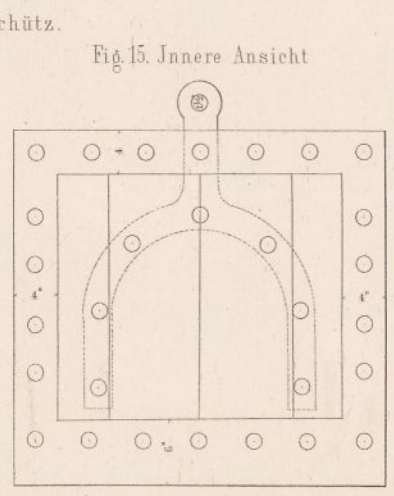

Fig. 15. Innere Ansicht.

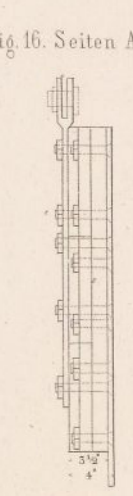

Fig. 16. Seiten Ansicht.

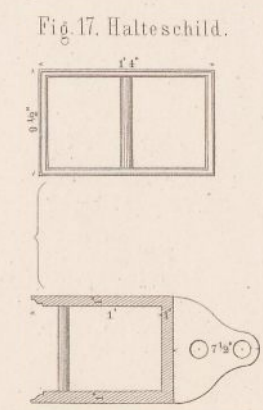

Fig. 17. Halteschild.



Fig. 20. Vorsteckling.

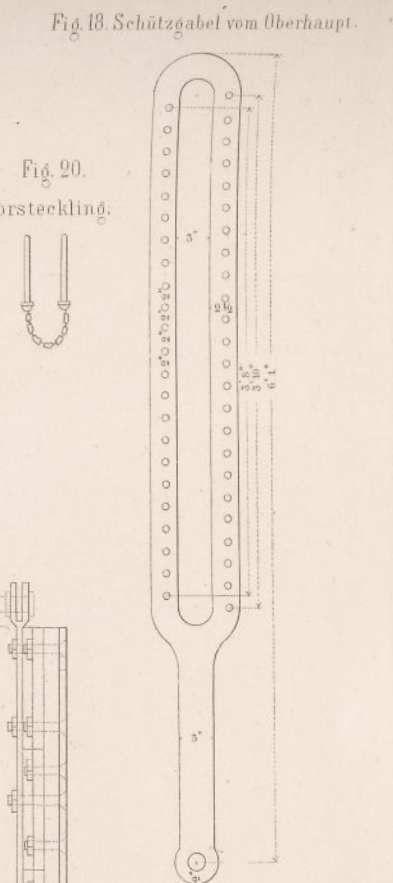

Fig. 18. Schützgabel vom Oberhaupt.

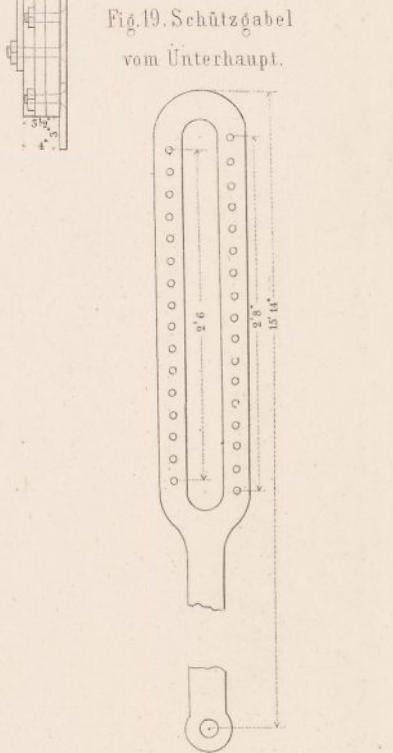
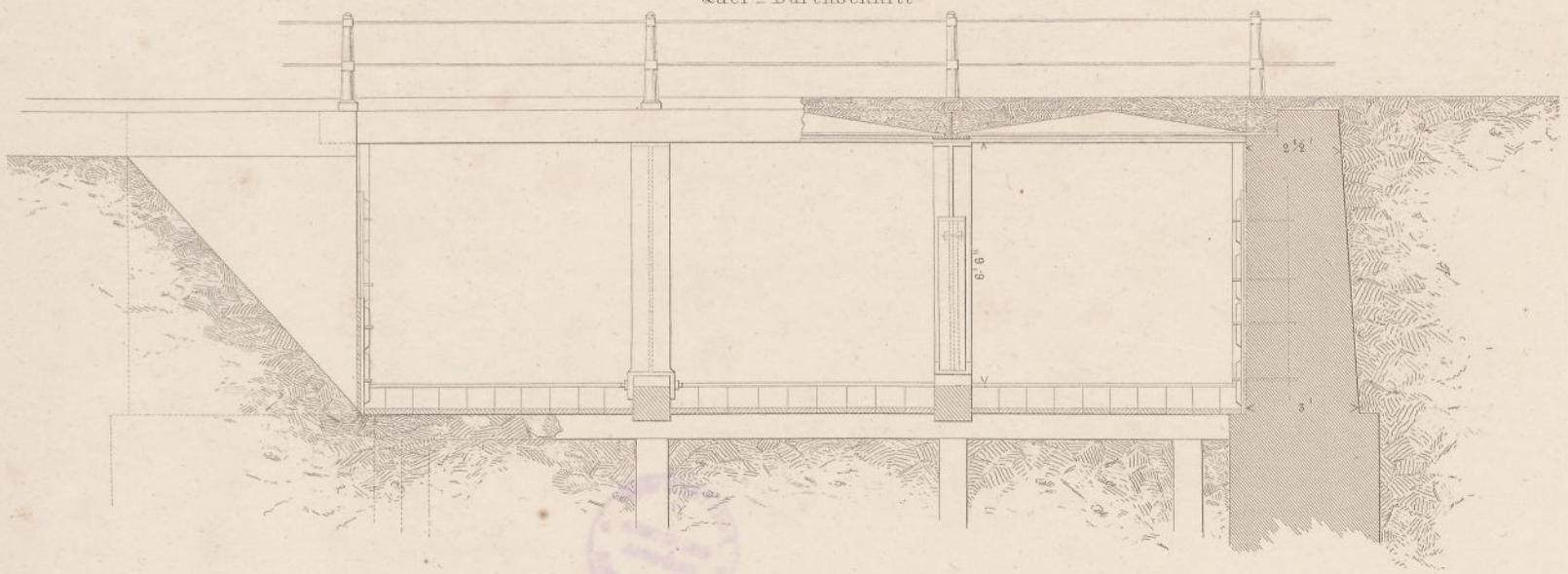

Fig. 19. Schützgabel vom Unterhaupt.





Quer-Durchschnitt



Längen-Durchschnitt

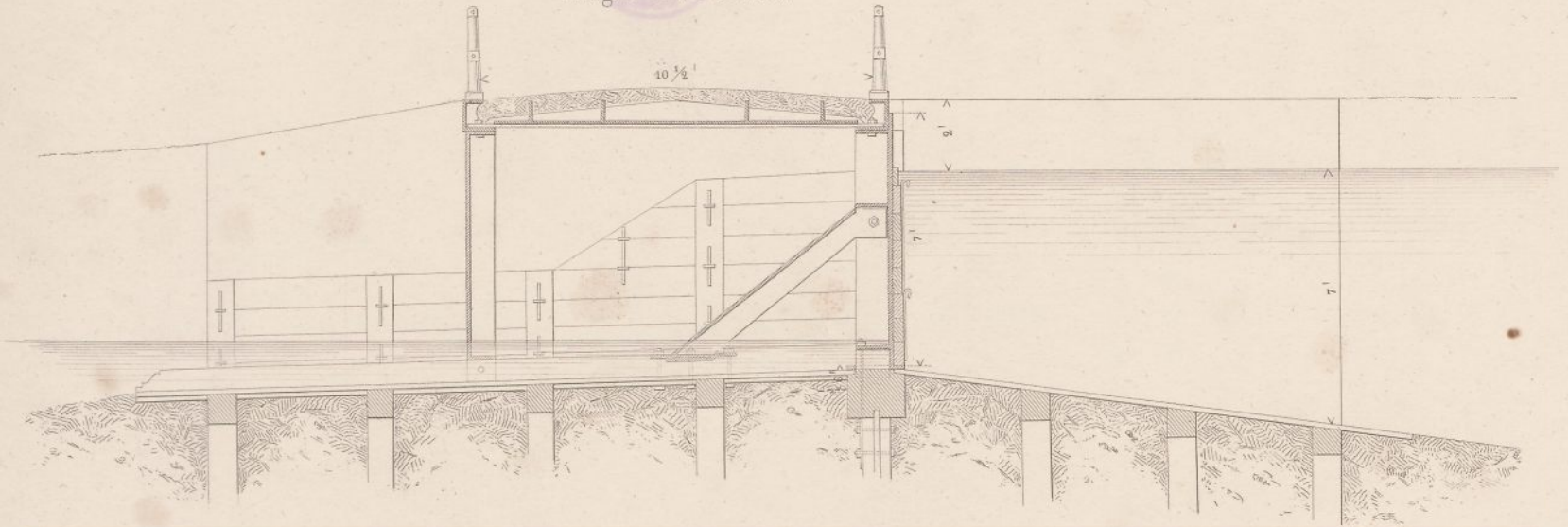

Grundriss

Freigraben

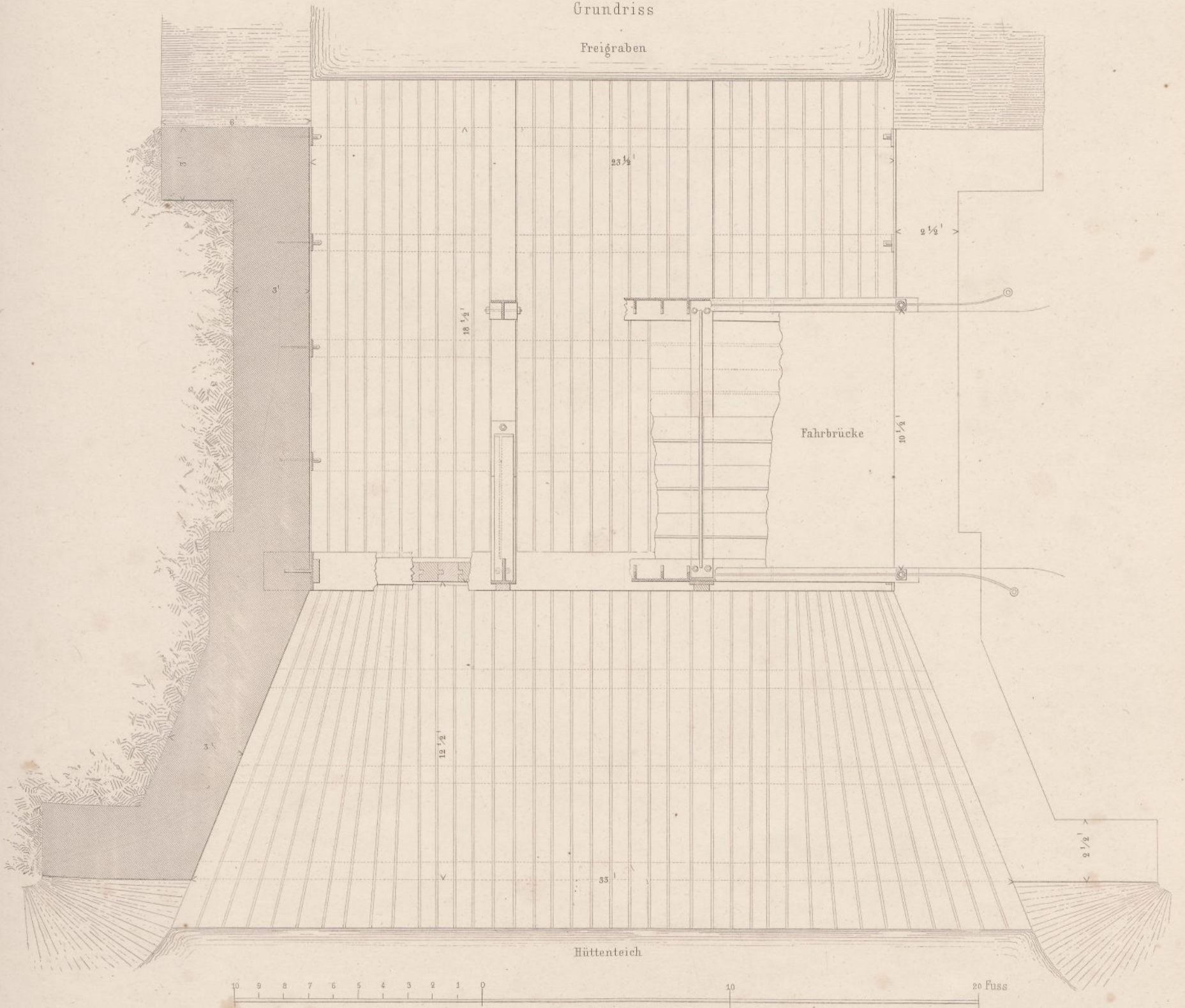

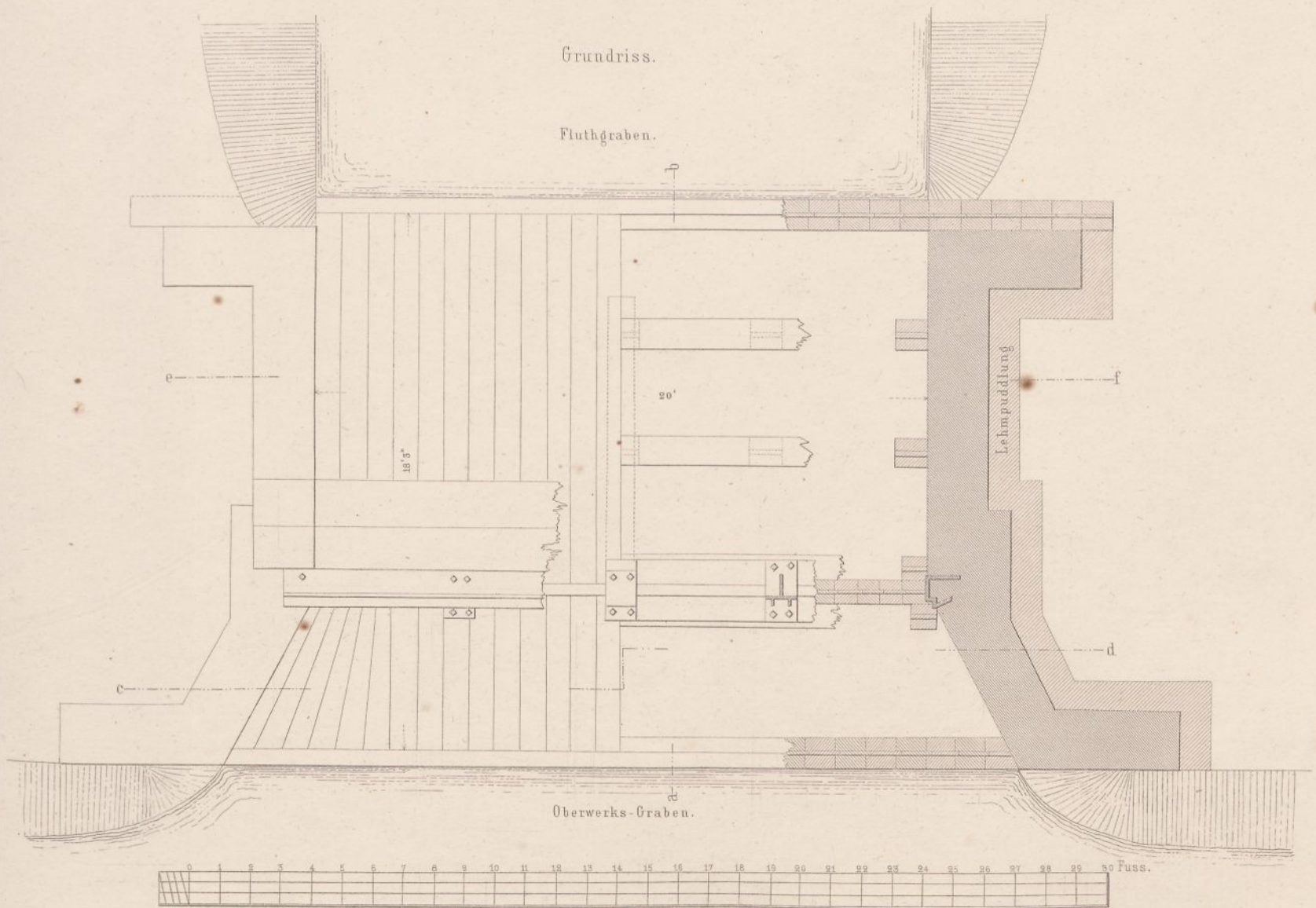
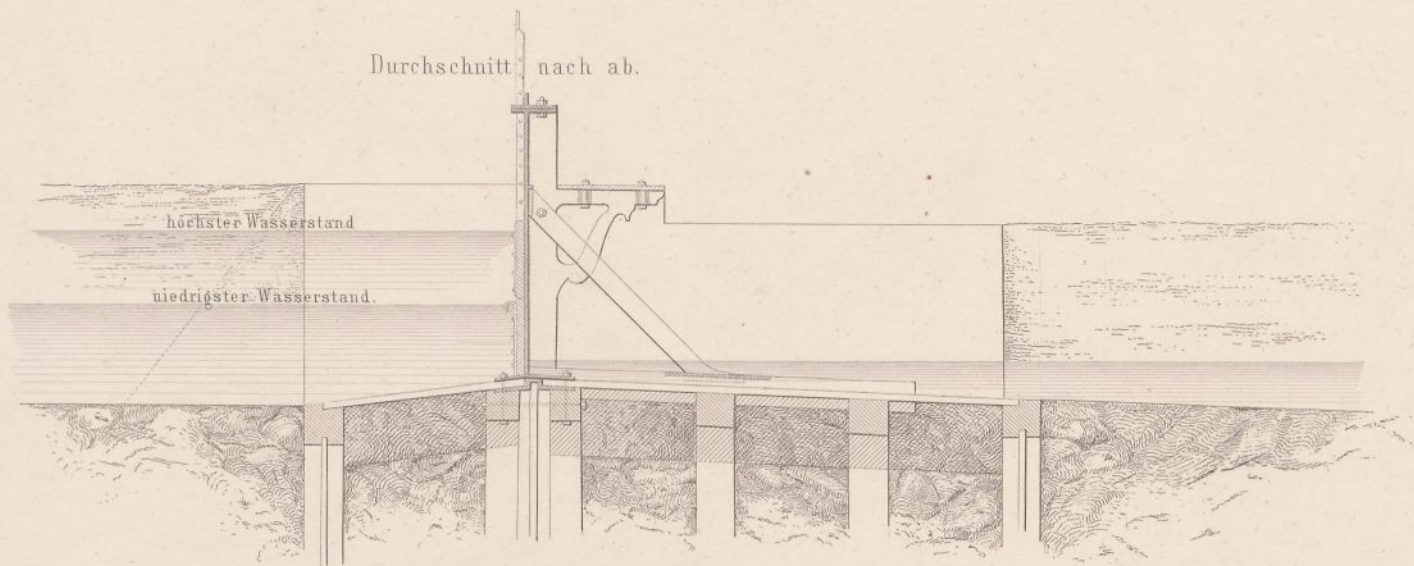
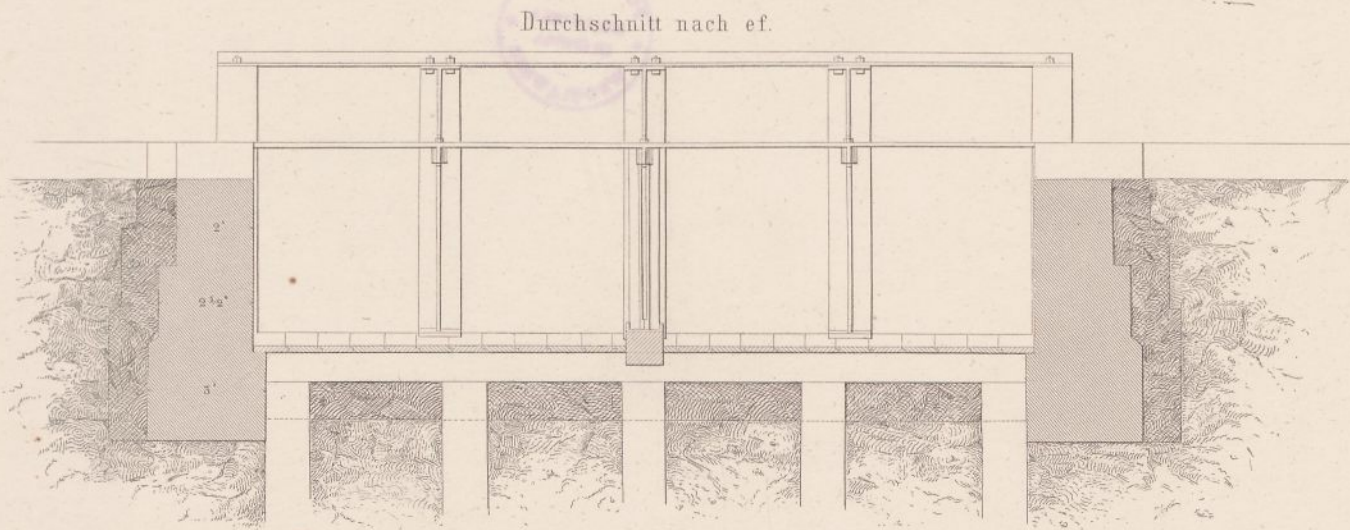
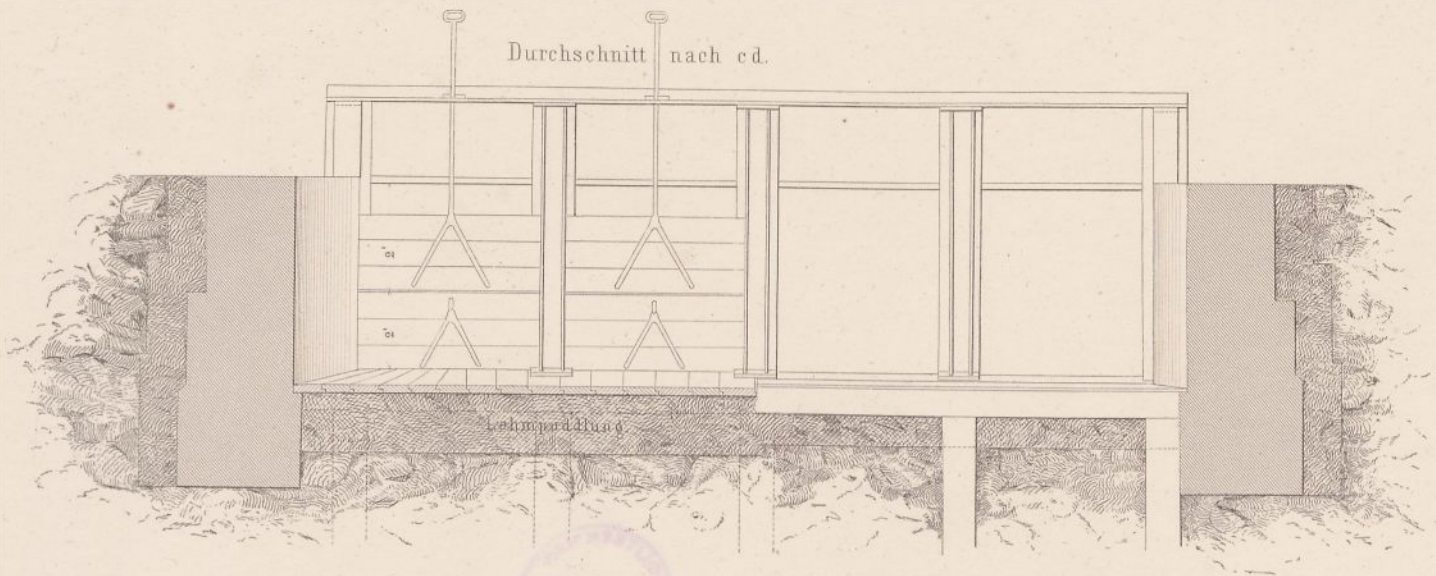

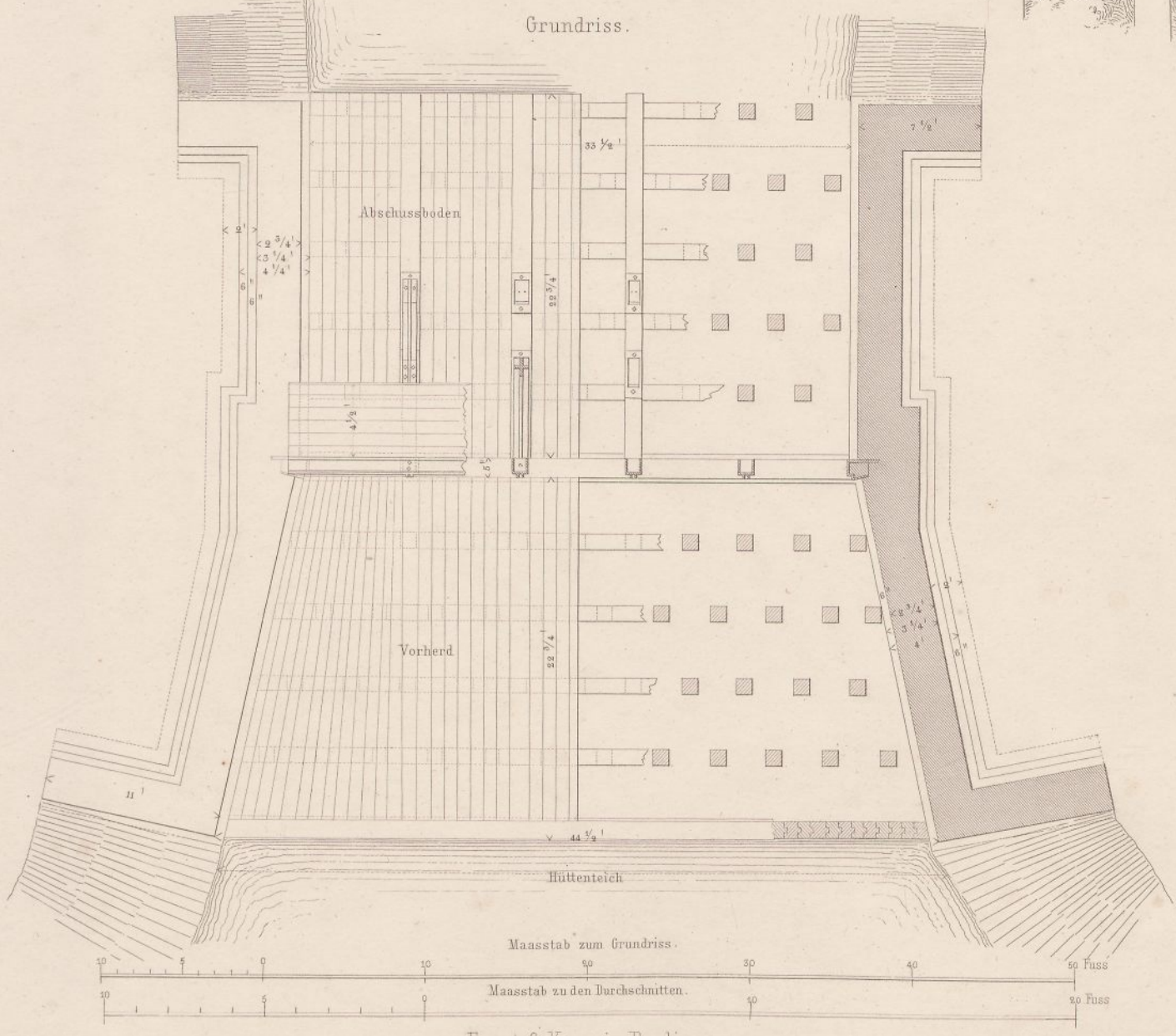
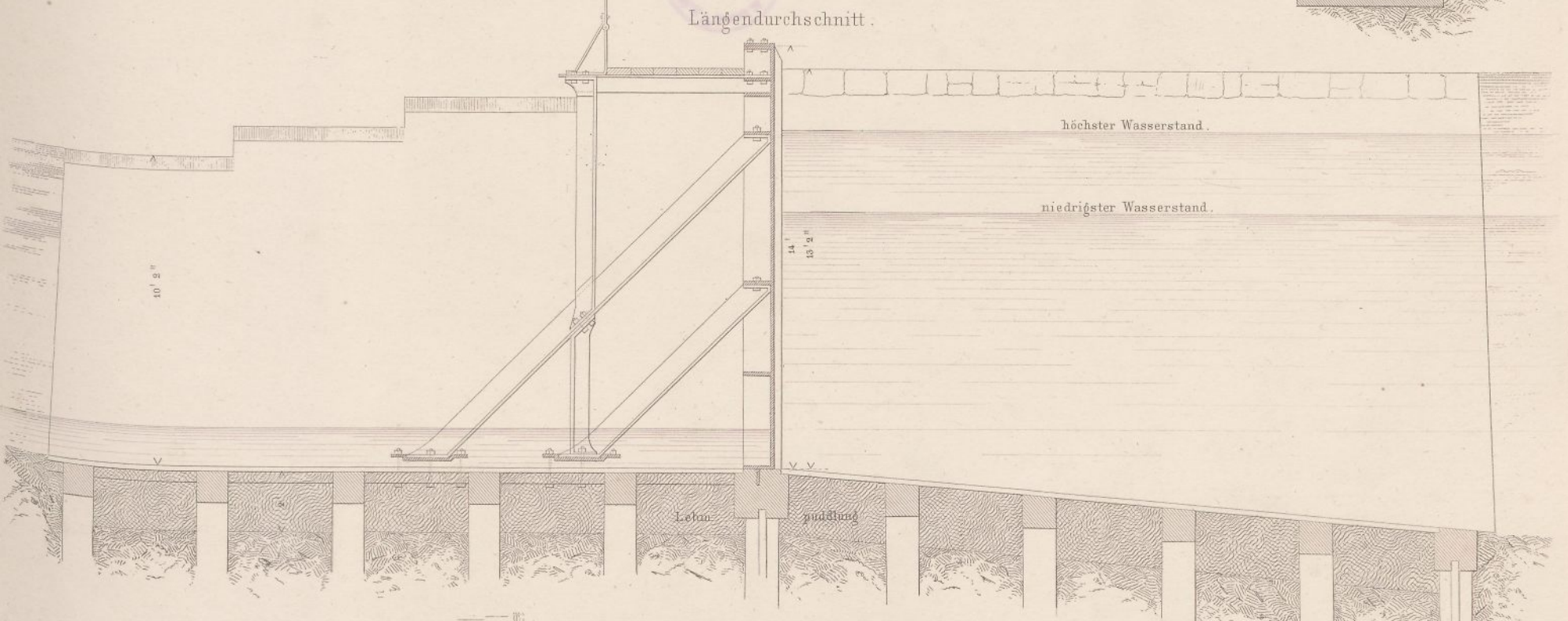
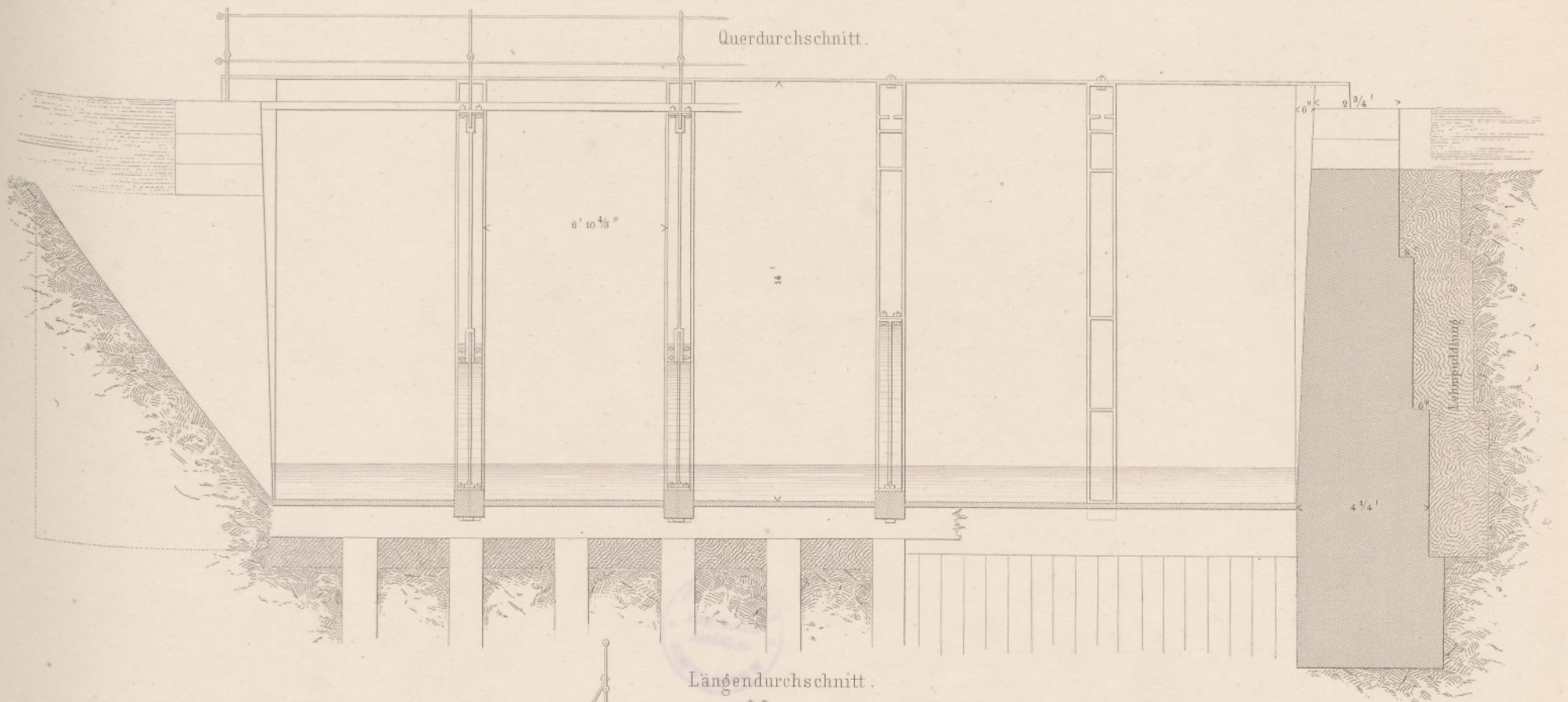

Fig. 5. Capitäl der einen inneren Säule.

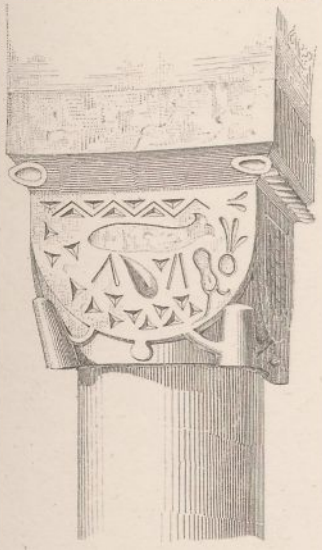

Fig. 6. Capitäl der anderen inneren Säule.

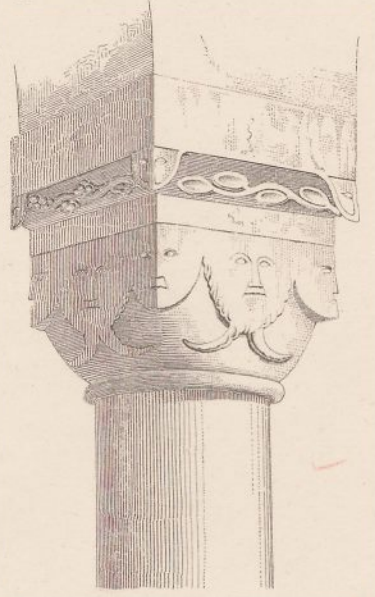

Fig. 1. Ansicht.

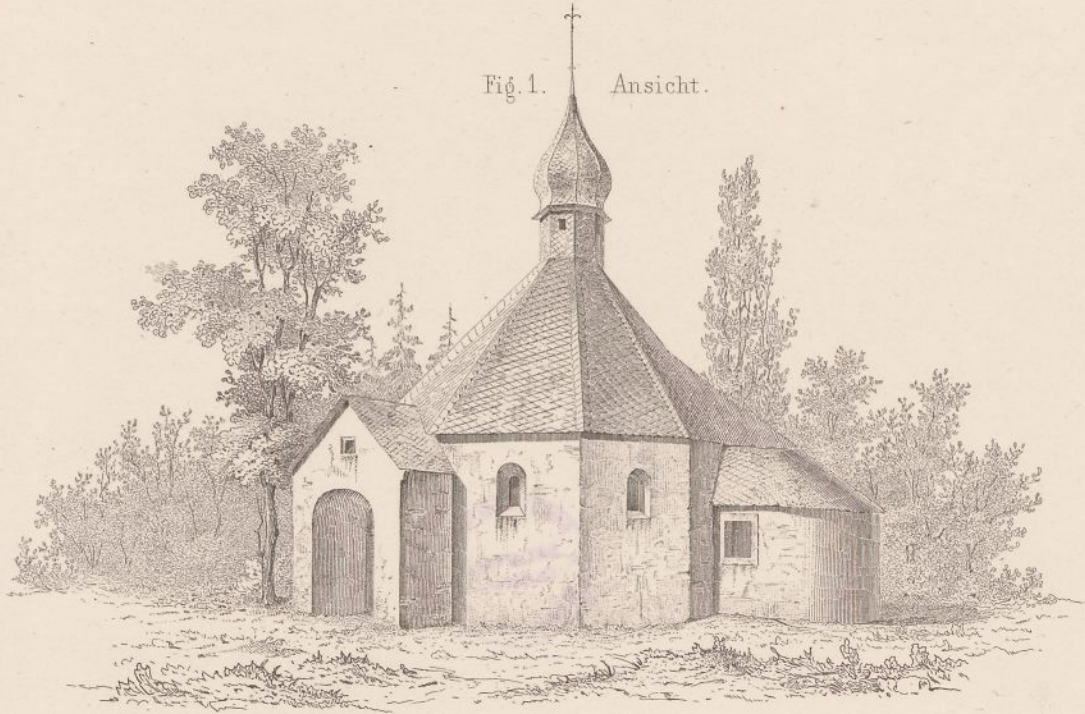

Fig. 2. Durchschnitt nach a b.

Fig. 7. Capitäl am Portal.

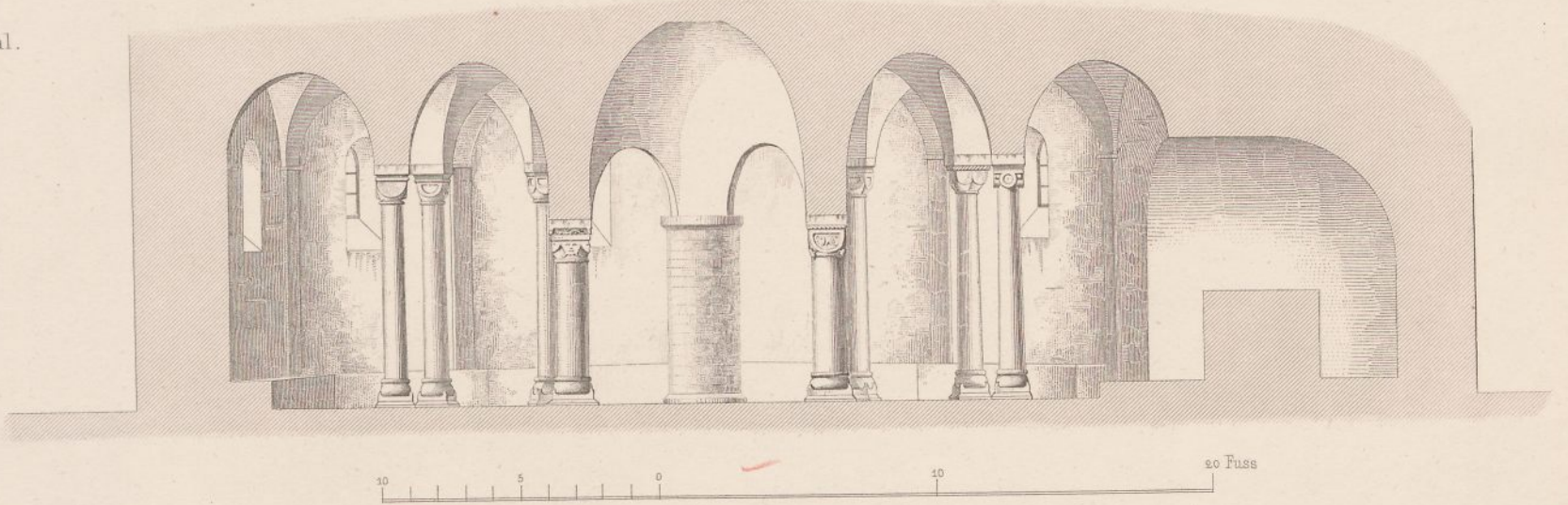
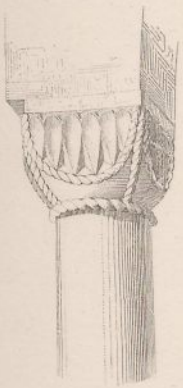

Fig. 3. Portal.

Fig. 8.

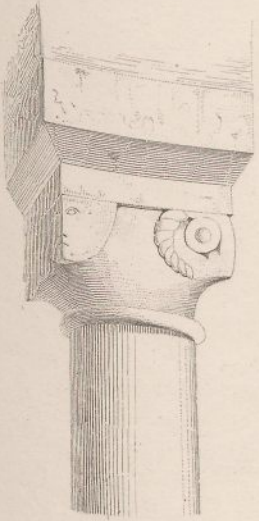

Fig. 9.



Capitäle des äusseren Säulenkranzes.

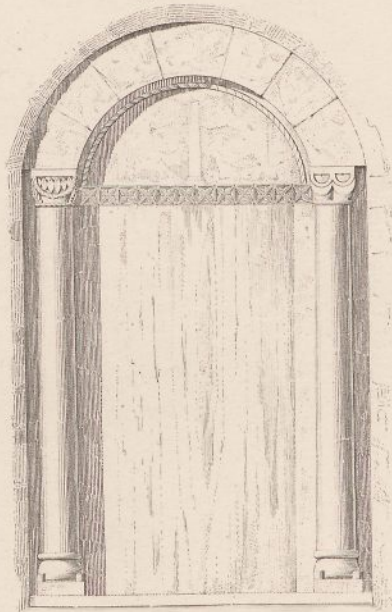

Fig. 10.

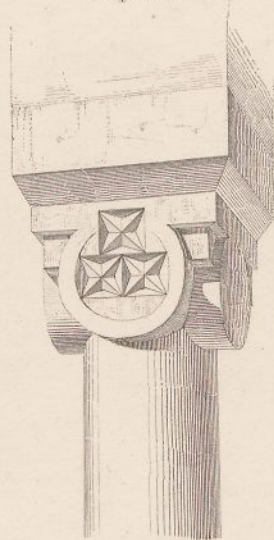

Fig. 11.

Capitäle des äusseren Säulenkranzes.

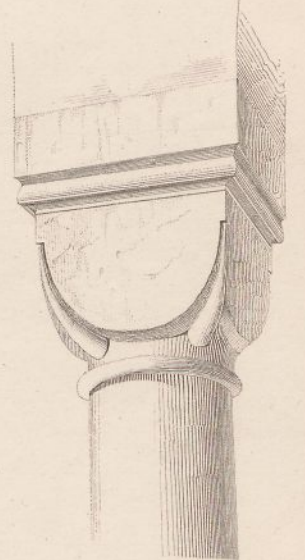

Fig. 12. Capitäl und Base.



Fig. 4. Grundriss.

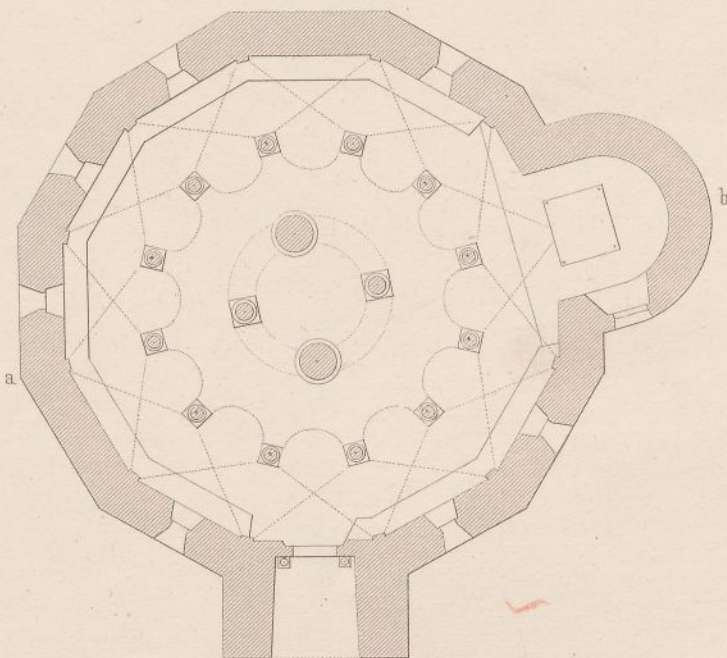

Fig. 13. Capitäl und Base.



Kloster Huysburg.



Fig. 1. Längendurchschnitt nach A B.

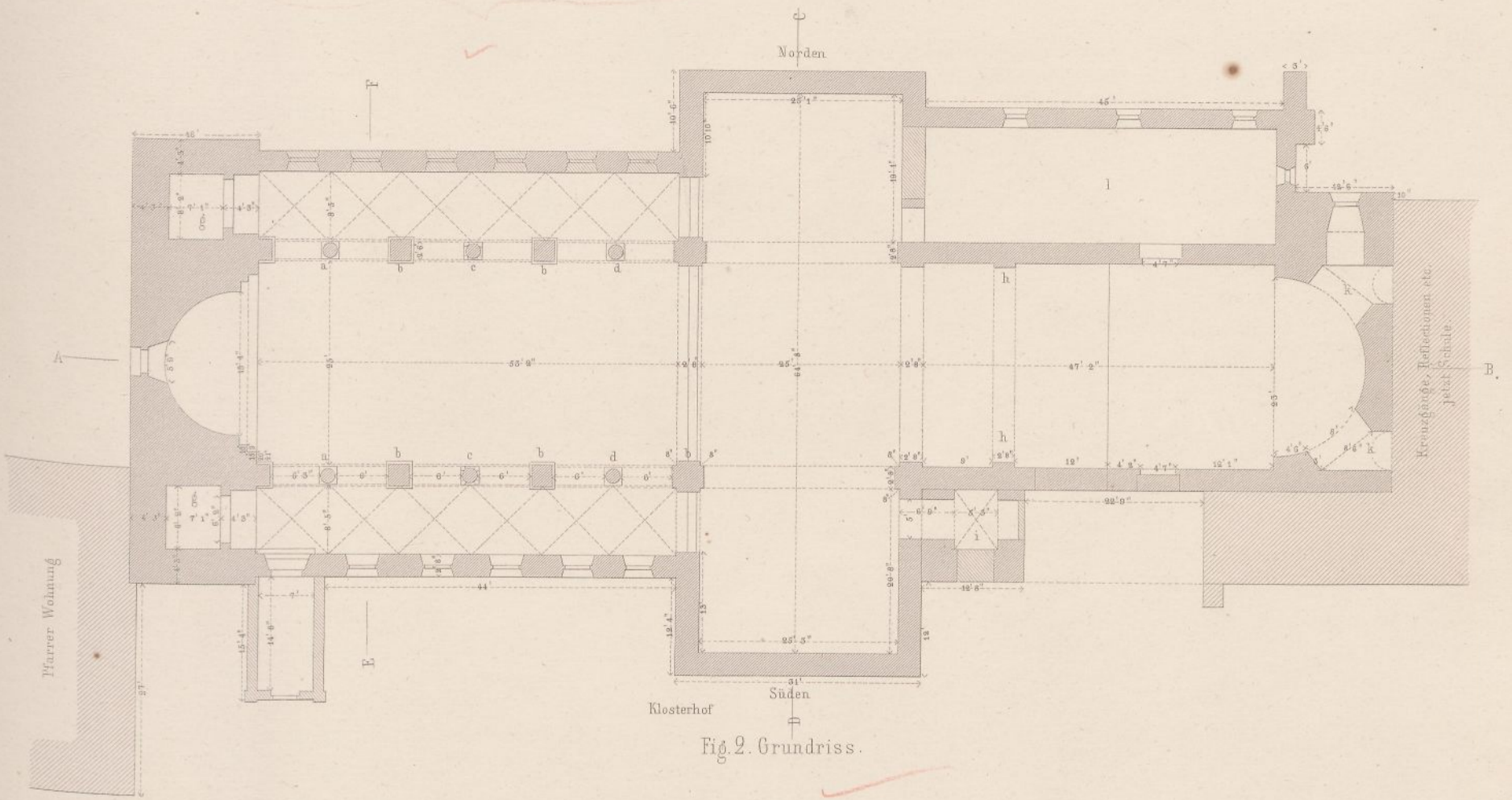

Fig. 2. Grundriss.



Fig. 3. Querschnitt nach C D.



Fig. 4. Querschnitt nach E F.

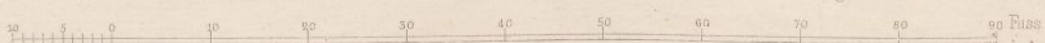

Fig. 1. Situations - Plan.

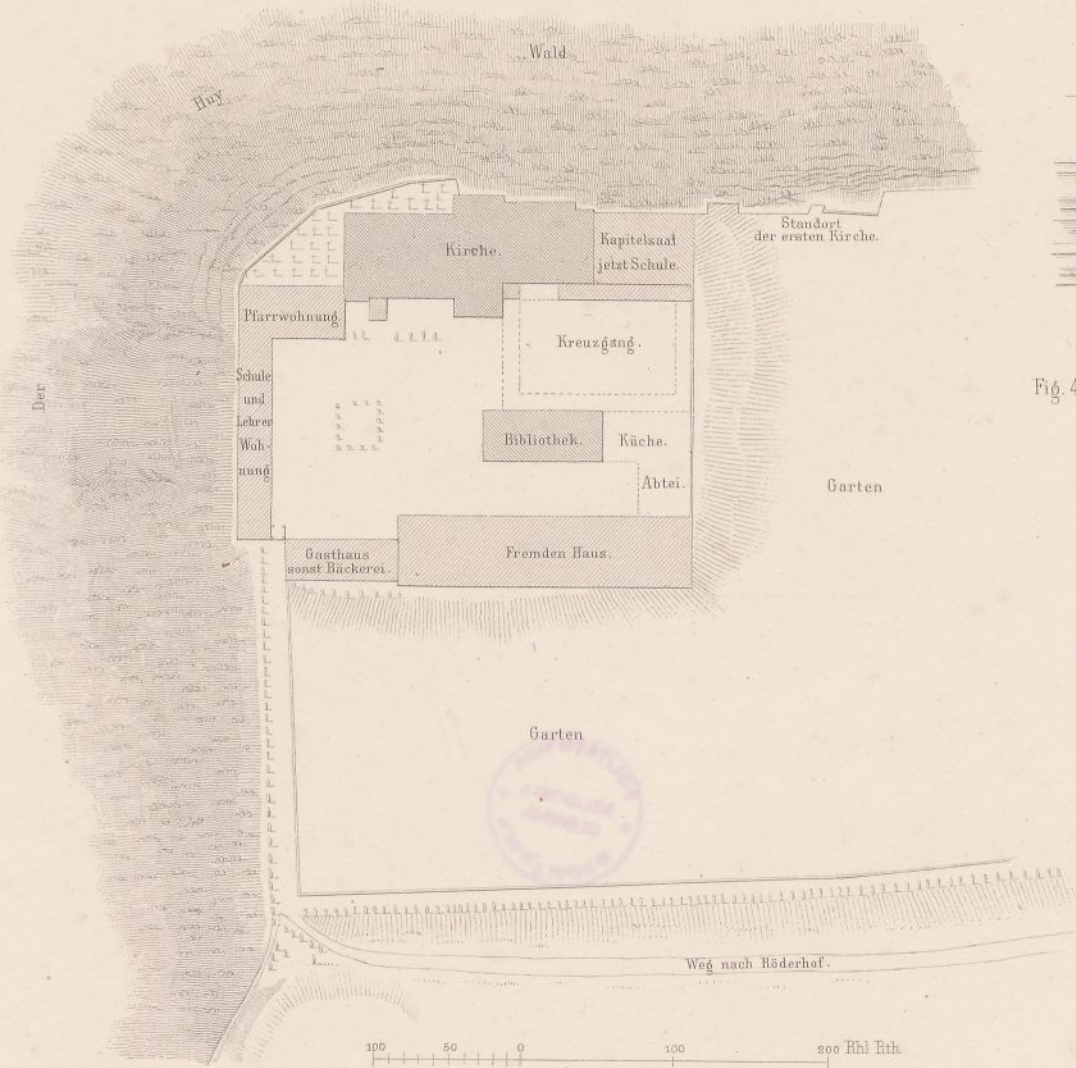

Fig. 2. Kämpfergesims.



Fig. 3. Kämpfergesims.

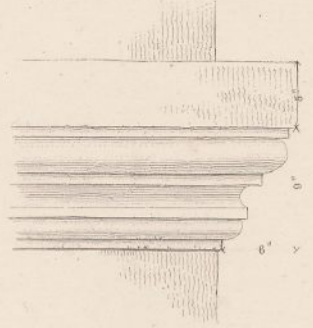

Fig. 4. Zahl am südl. Kreuzgiebel.



Fig. 5. Fenster des Mittelschiffs.

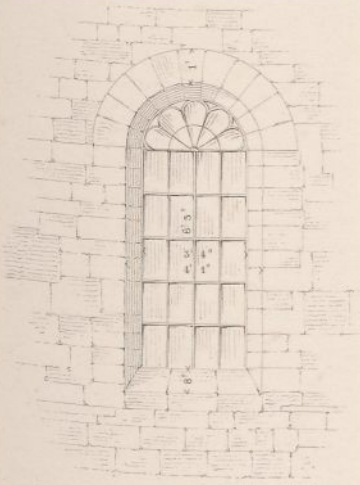

Fig. 6. Pfeilerbase.

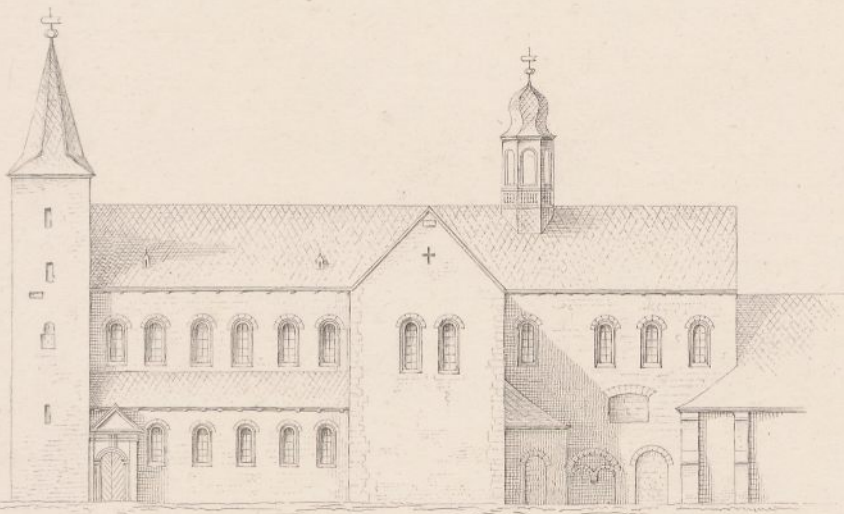
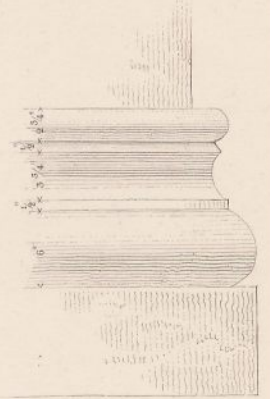

Fig. 7. Südliche Ansicht der Kirche.

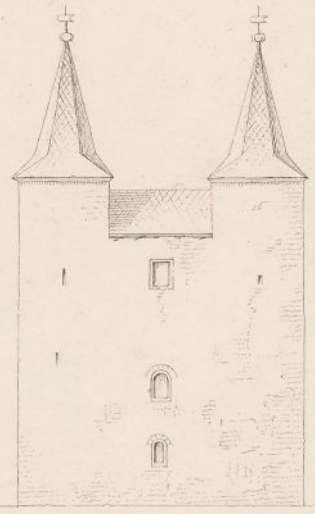

Fig. 8. Nördliche Ansicht der Kirche.

Fig. 9.

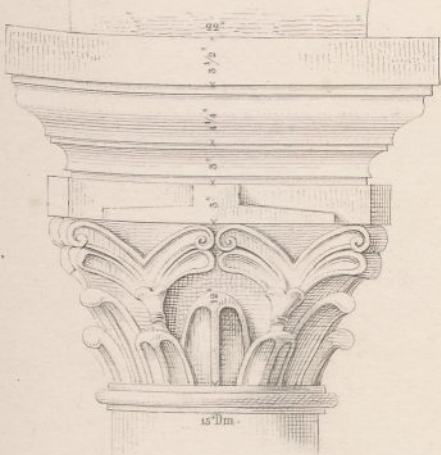

Fig. 10.

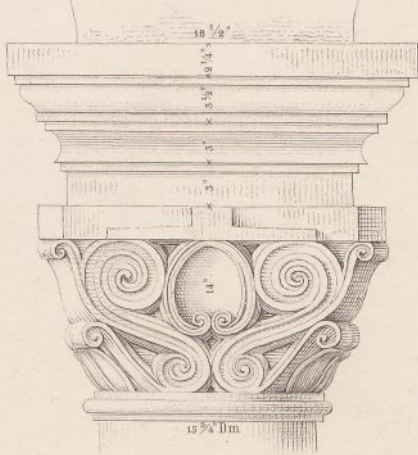
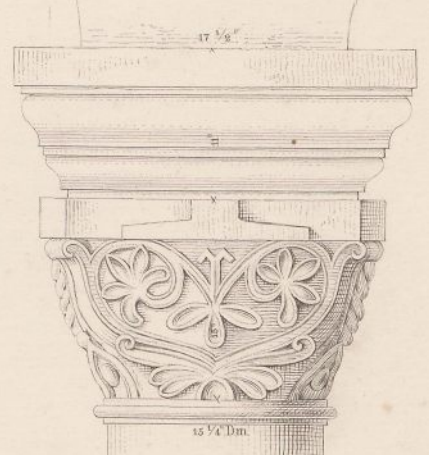
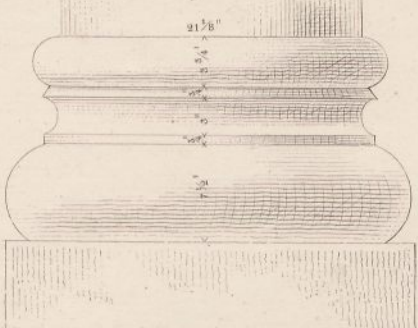

Fig. 11.



Details.

Fig. 13.



Säulen.

Fig. 14.

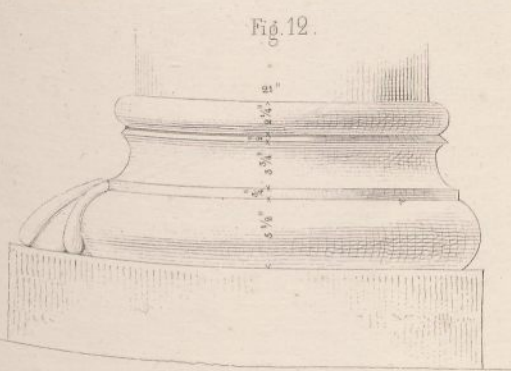
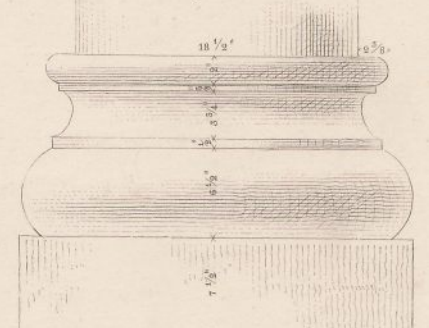
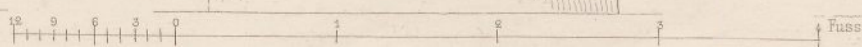
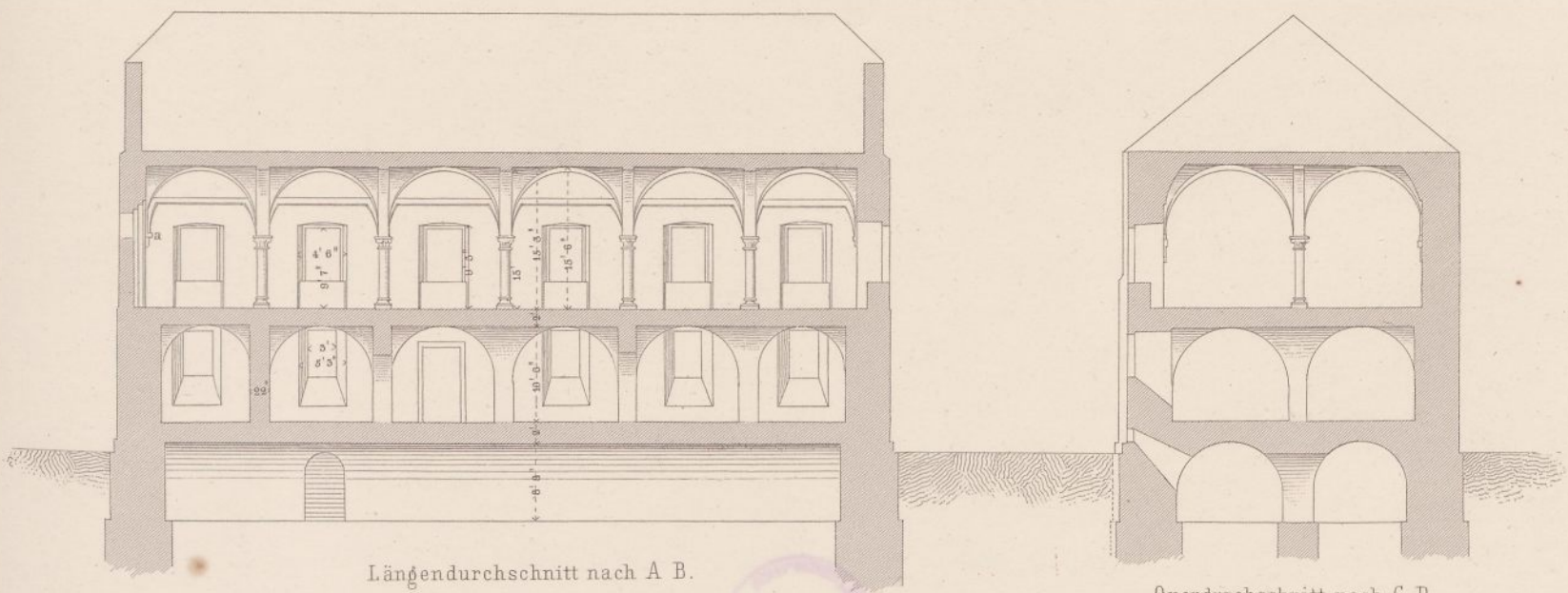

Fig. 12.



Bibliothek - Gebäude.



Längendurchschnitt nach A B.

Querdurchschnitt nach C D.

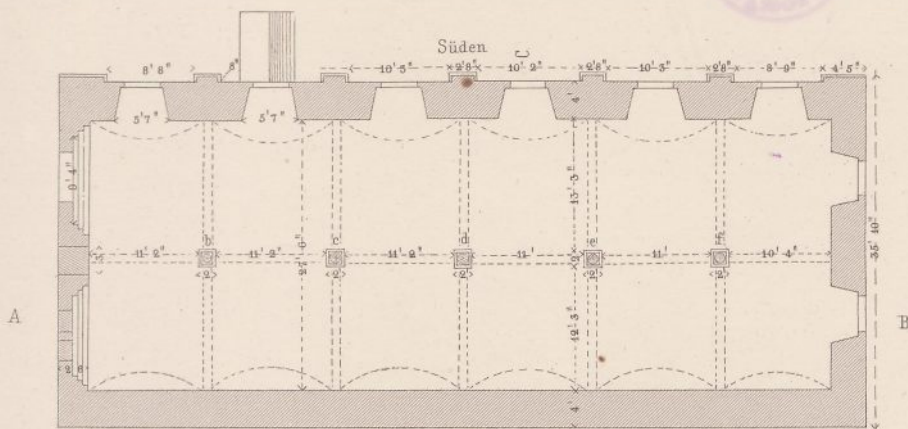

Grundriss des ersten Geschosses.

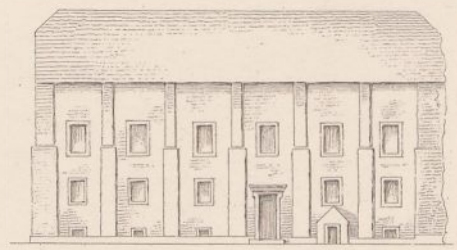

Vorder Ansicht.

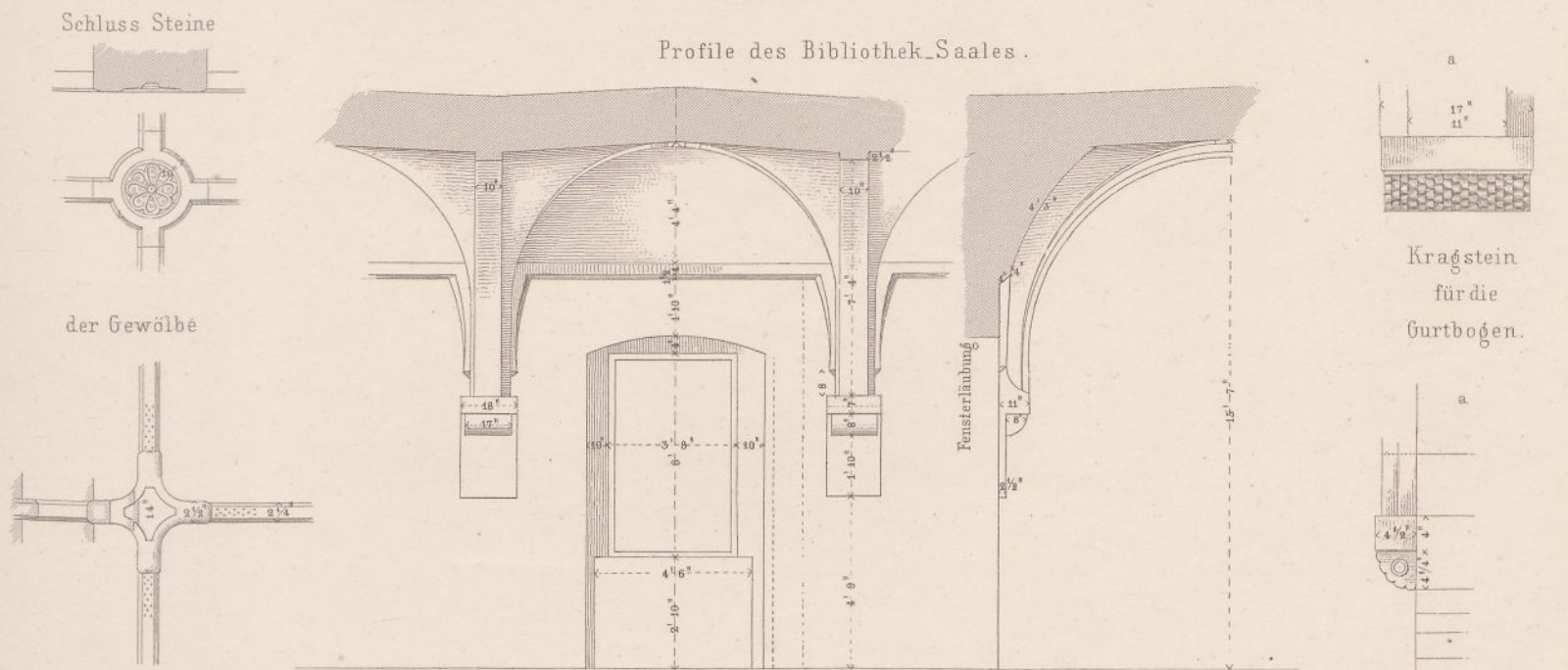

Profile des Bibliothek-Saales.

Details der Säulen

des Bibliothek-Saales.

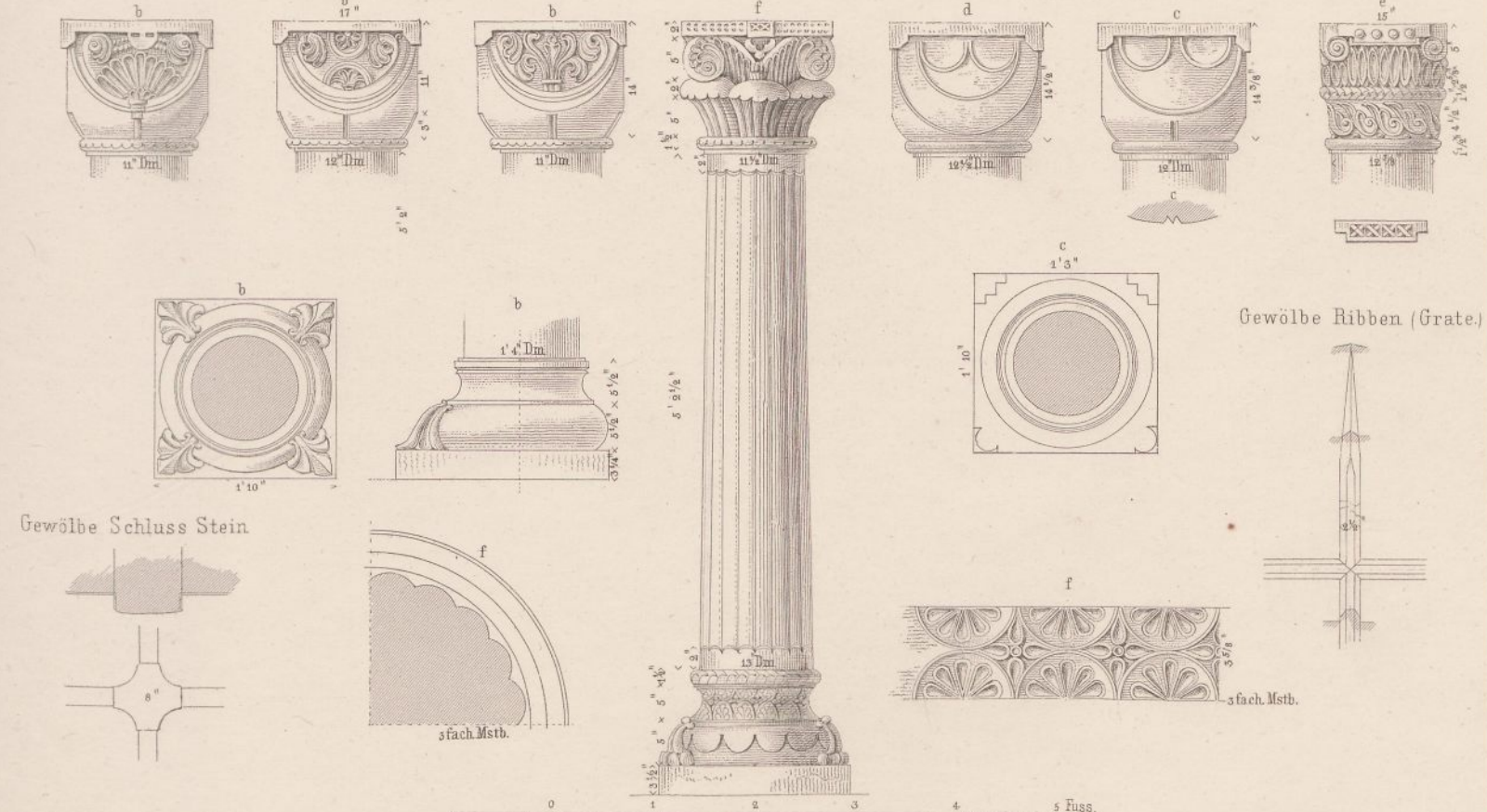

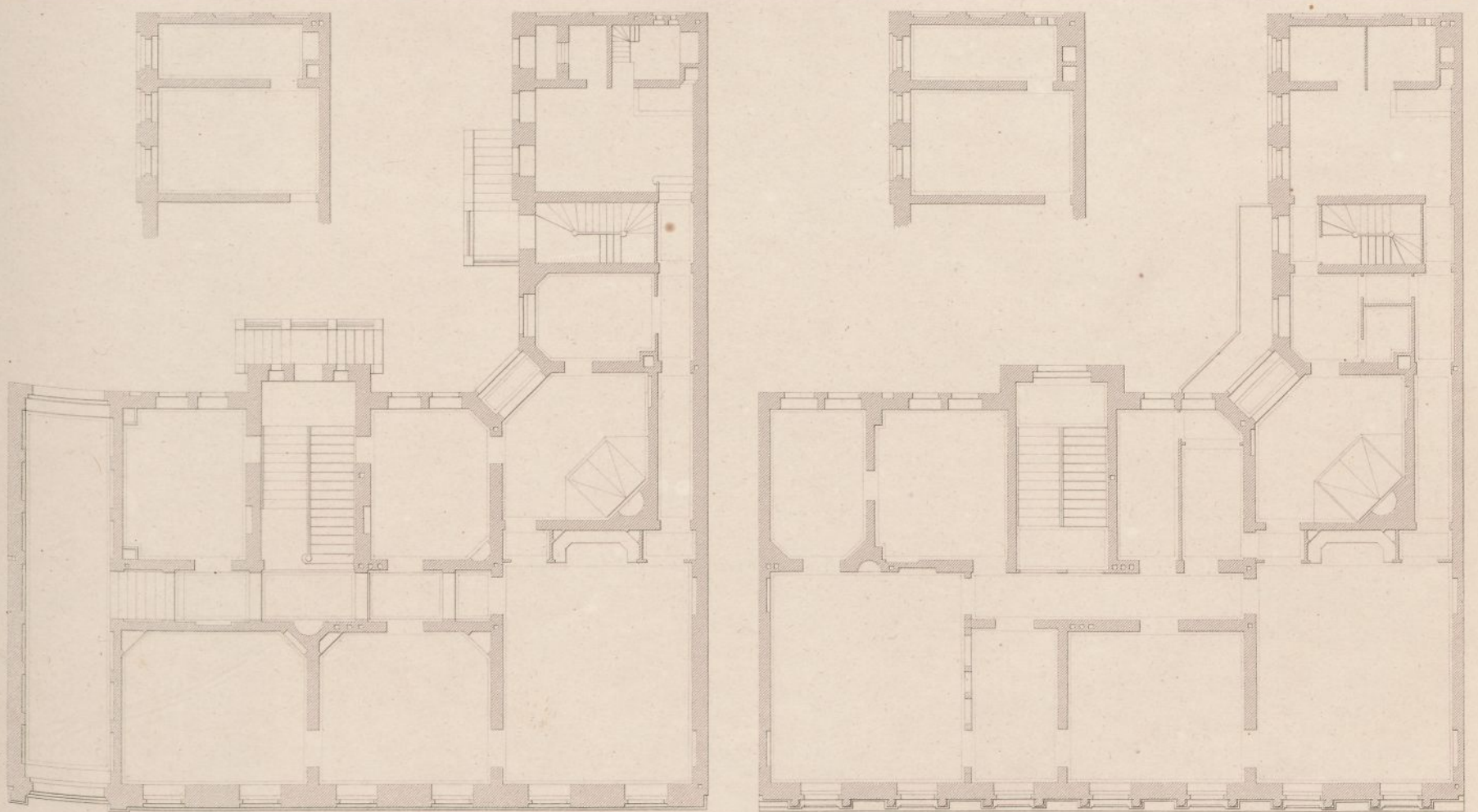



WOHNHAUS IN BERLIN.



Durchschnitt durch den Flur.

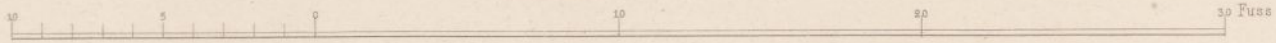

Hauptgesims.

Fenster des 1<sup>ten</sup> Stocks.

Theil der Hof-Façade.

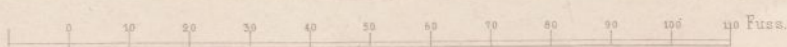
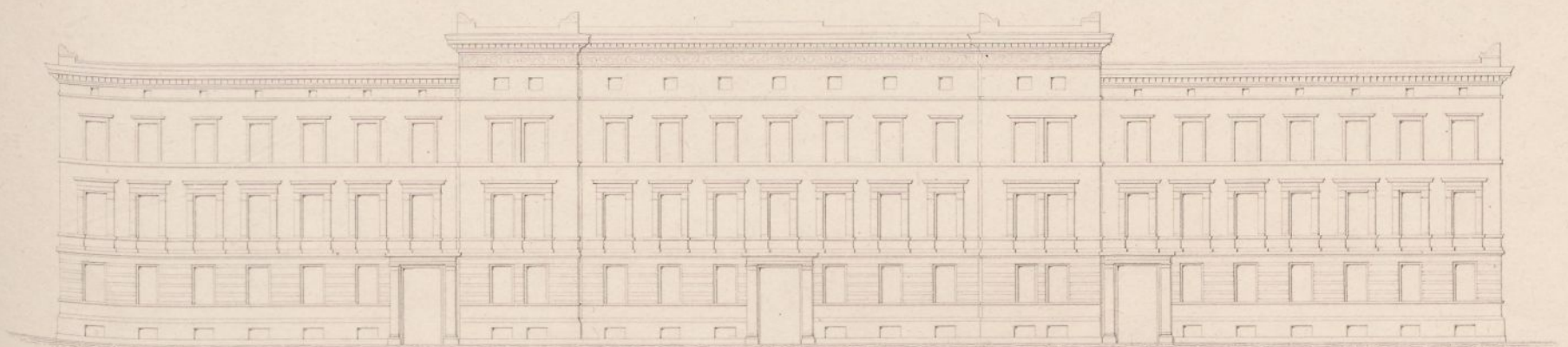
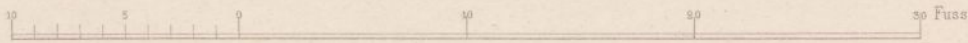

Elb-Brücke bei Wittenbergen  
Brücke über die Taube-Elbe.

Fig. 1

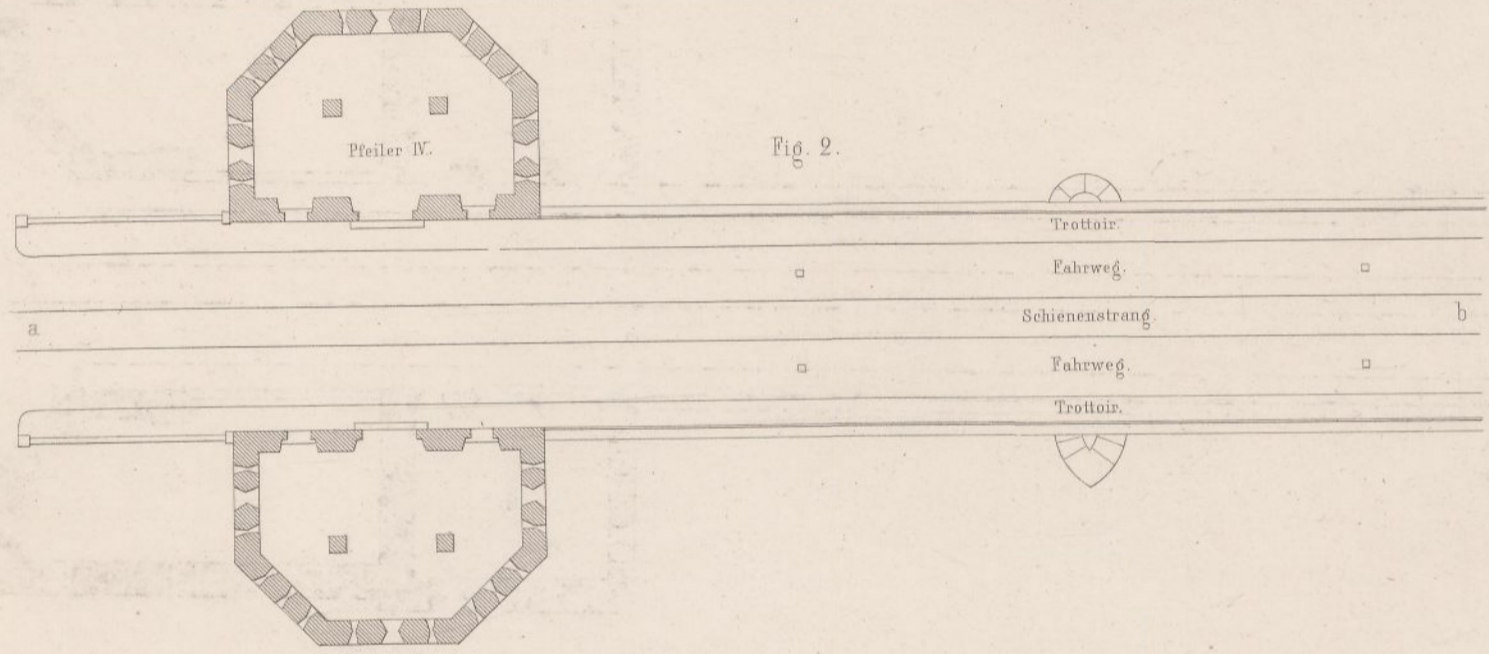
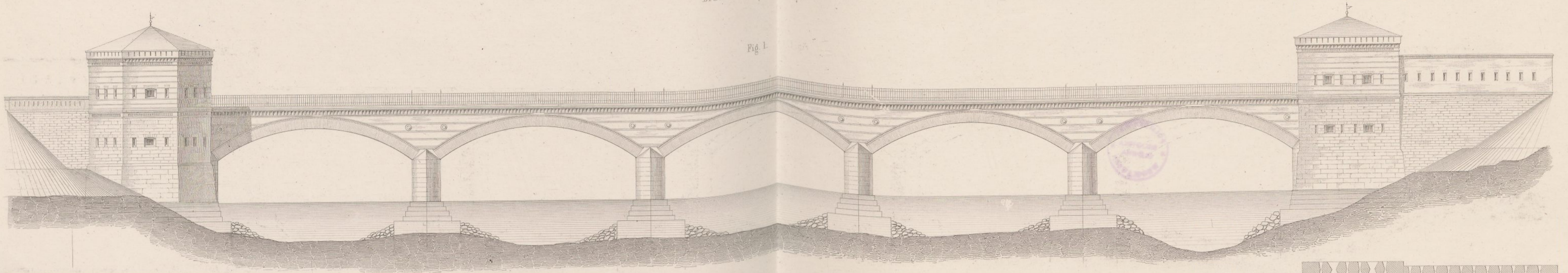
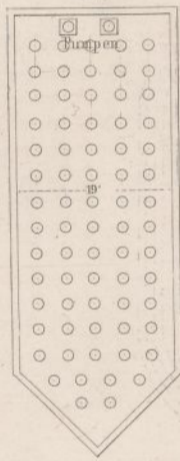

Fig. 2.

Trottoir  
Fahrweg  
Schienenstrang  
Fahrweg  
Trottoir

Fig. 3.



Grundriss

Fig. 4.

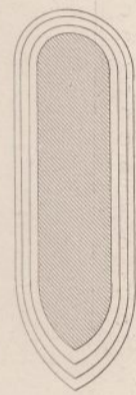

Querdurchschnitt

Fig. 5.

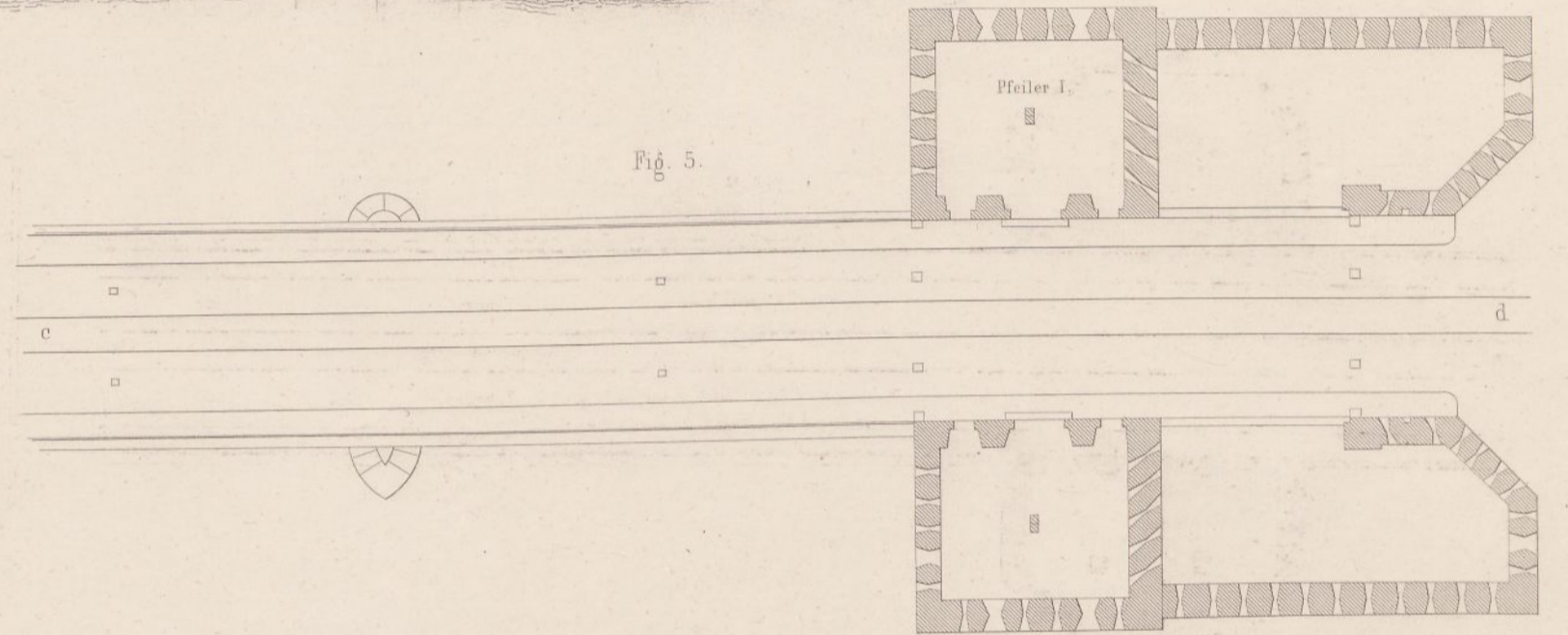

durch den Scheitel des Bogens.

Fig. 7.

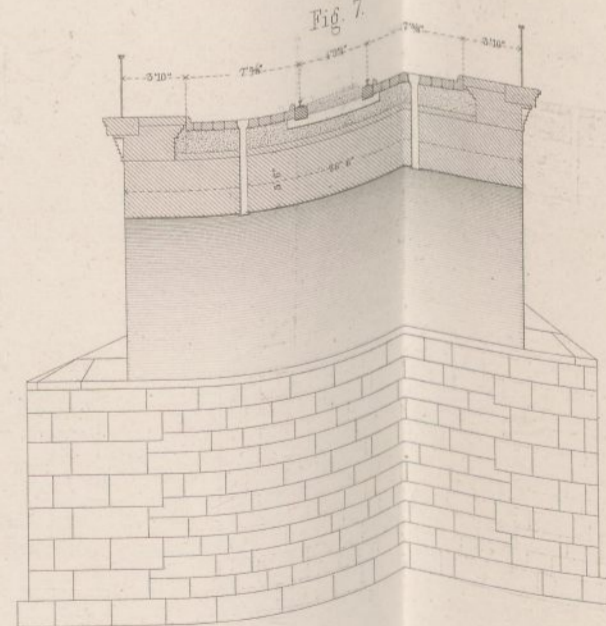

am Widerlager.

Fig. 8.

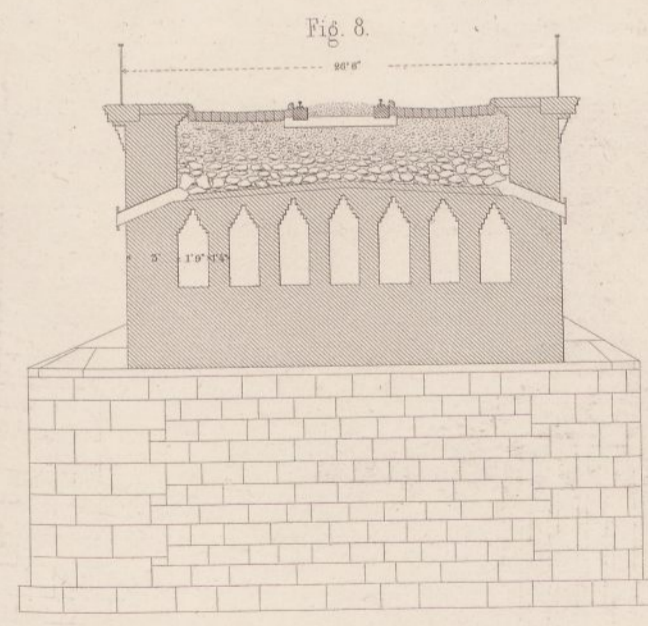

Längendurchschnitt

nach c d des Grundrisses.

Fig. 9.

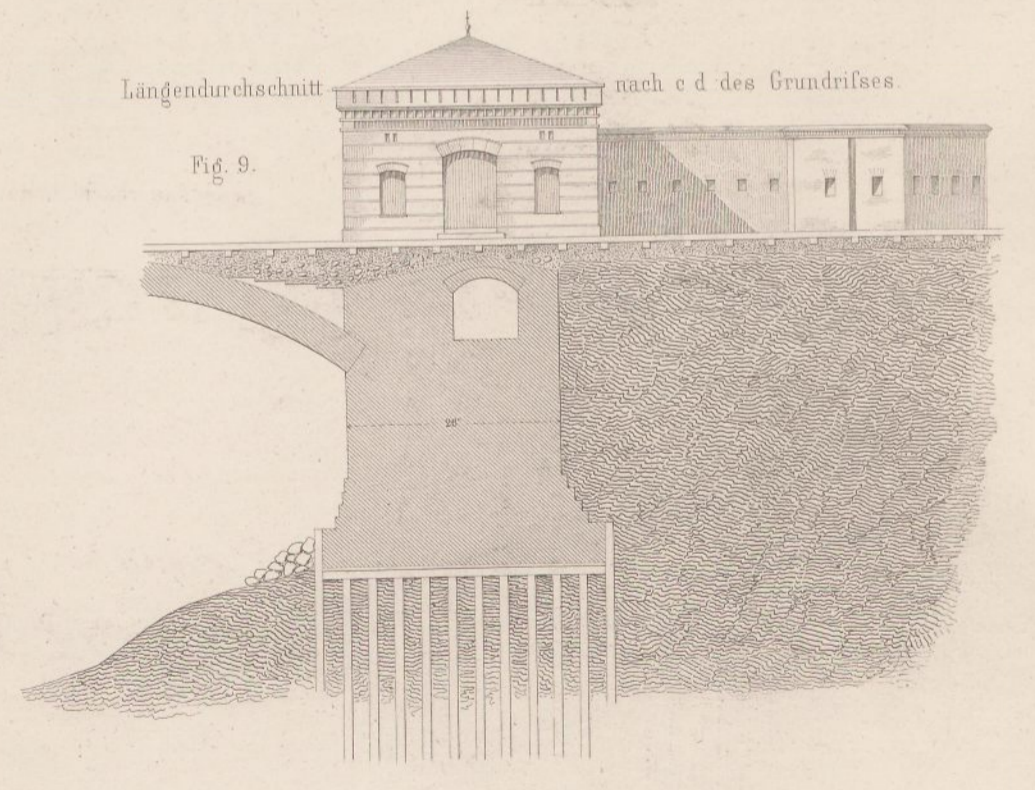

Längendurchschnitt nach a b des Grundrisses.

Fig. 6.

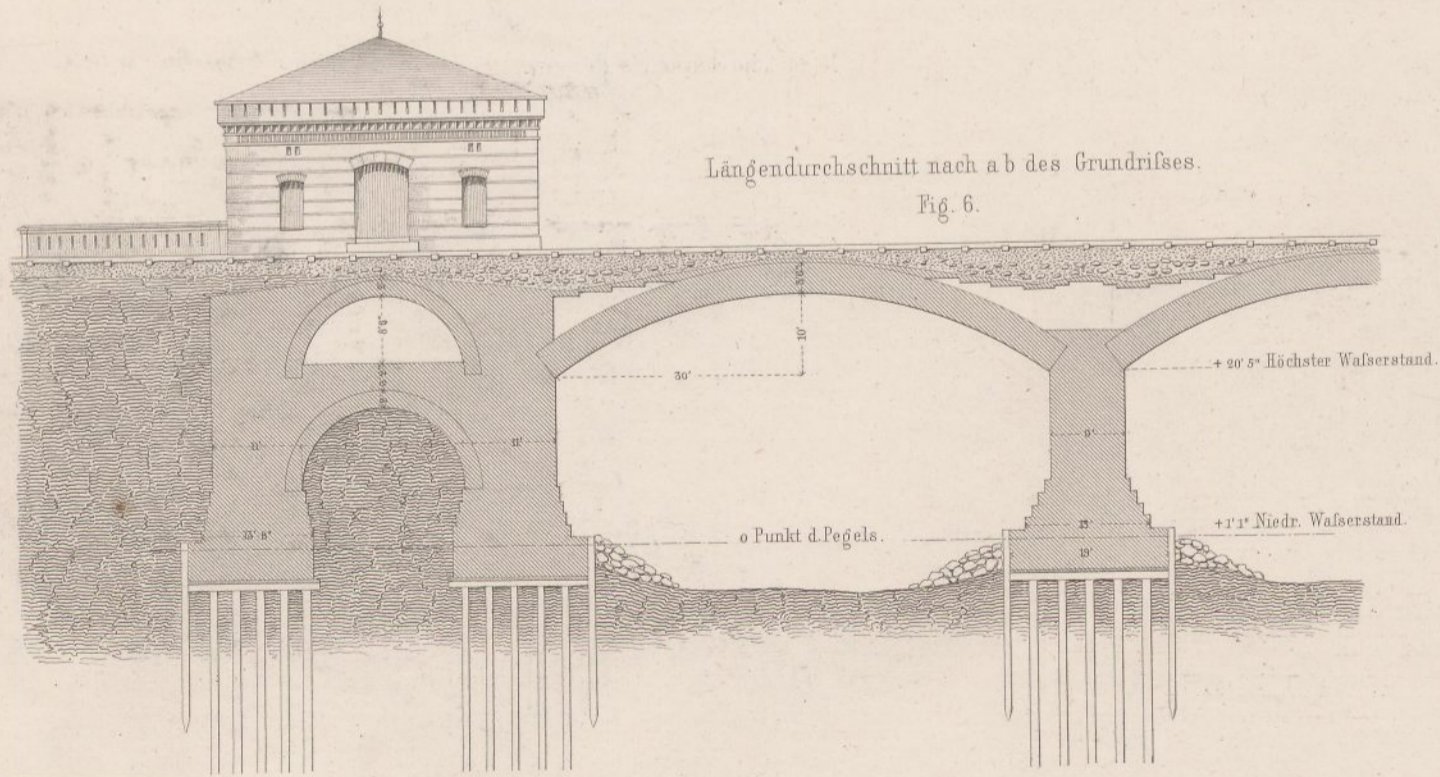

Maaßstab zu Fig. 1-6 u. Fig. 9.

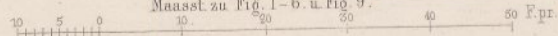

Maaßstab zu Fig. 7-8.

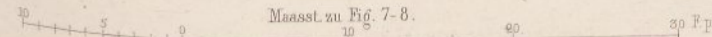

Elbbrücke bei Wittenberge.  
Gewölbe nebst Lehrbögen der Fluthbrücken.

Ansicht.

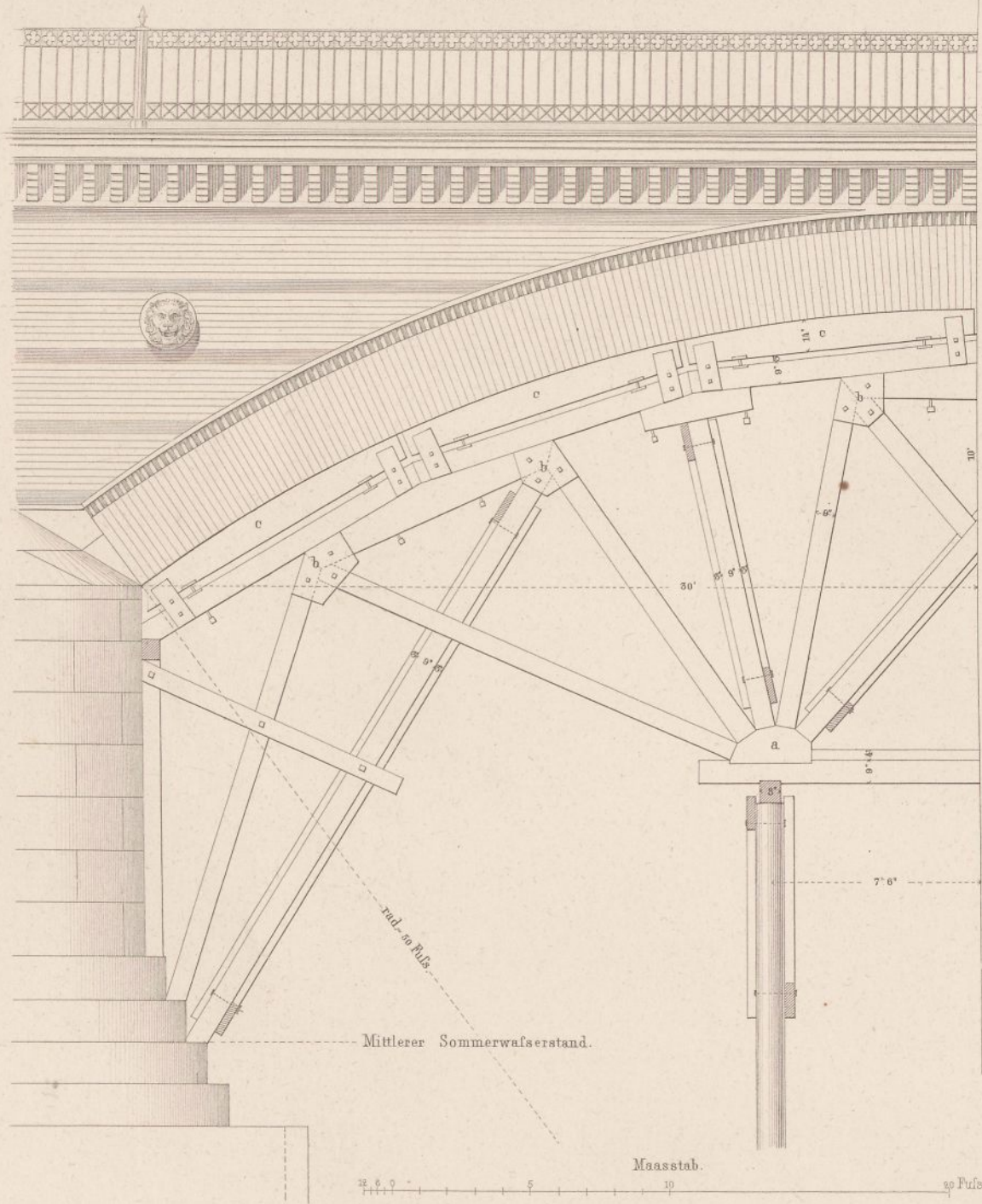

Querschnitt.

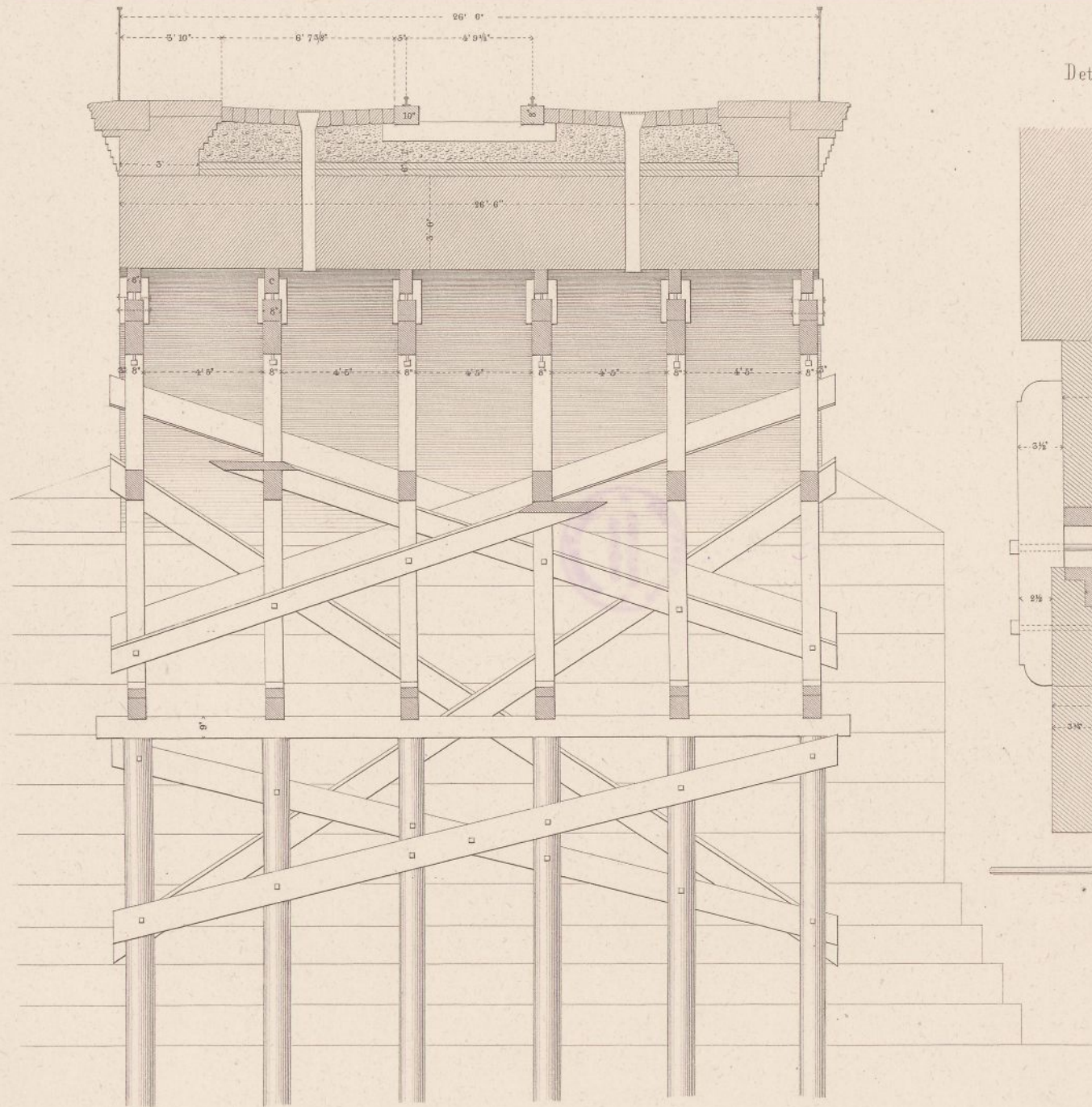

Detail der Schrauben.

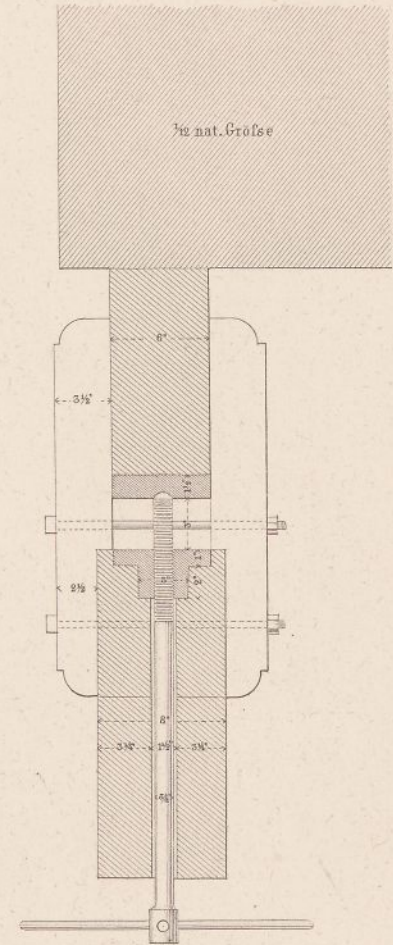



BRÜCKE ÜBER DIE NETLITZ  
bei Potsdam.

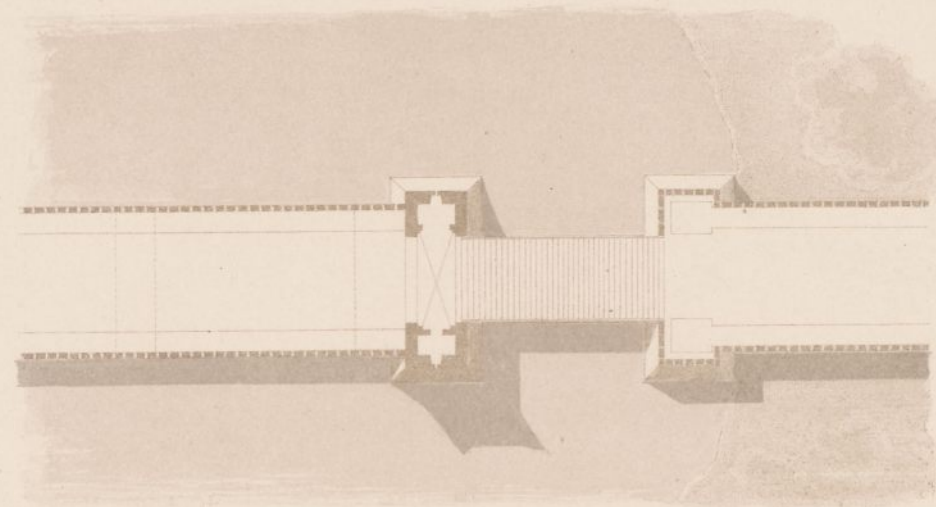

Fluss-Dampfbagger für die Melioration des Nieder-Oderbruchs.

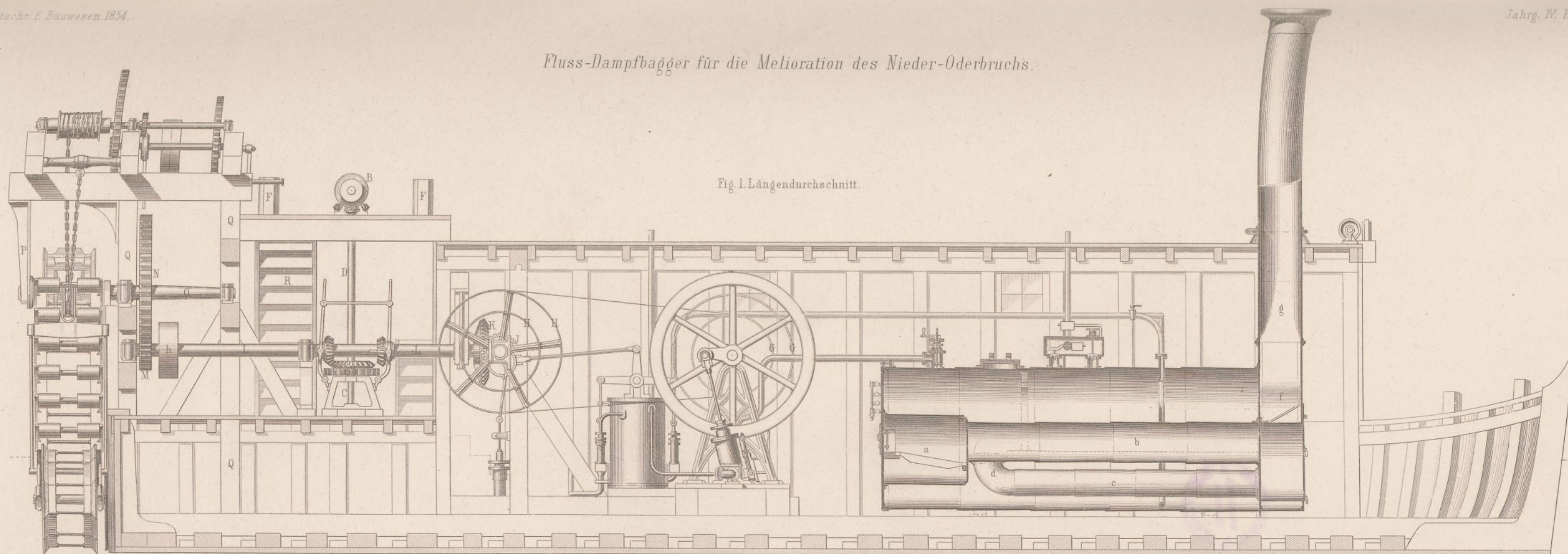

Fig. 1. Längendurchschnitt.

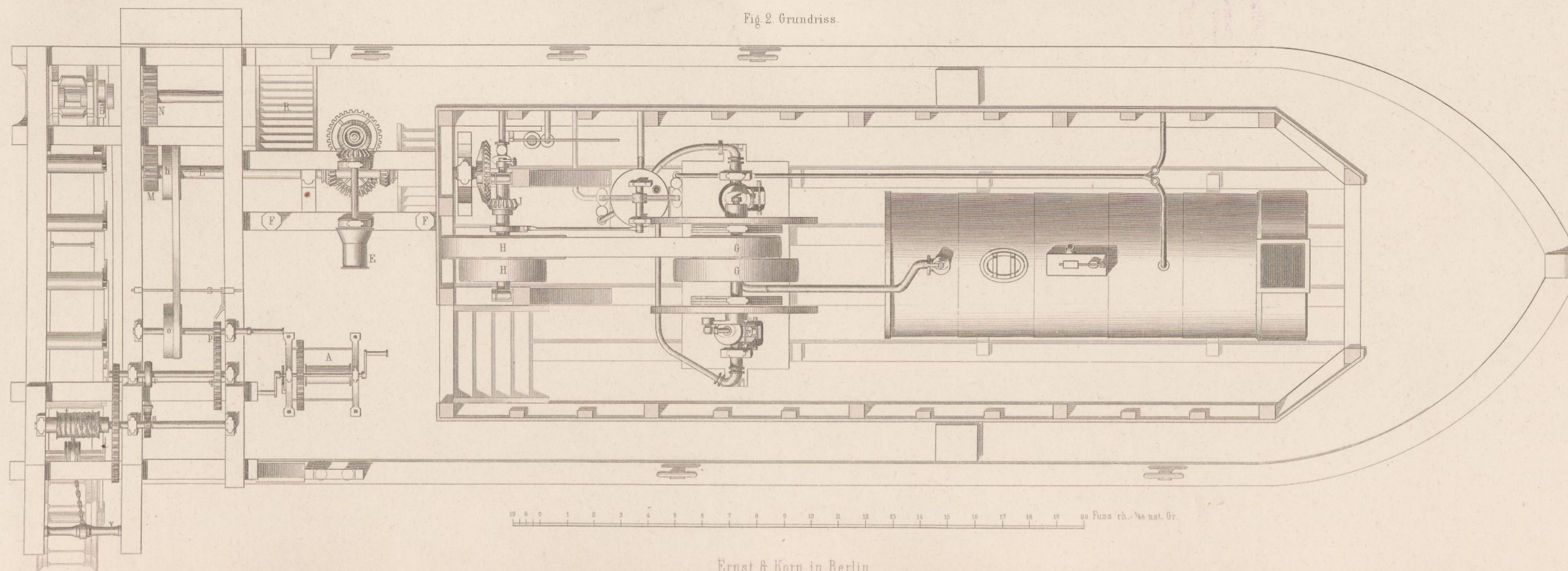

Fig. 2. Grundriss.

0 1 2 3 4 5 6 7 8 9 10 11 12 13 14 15 16 17 18 19 20 Fuss rh. - 1/4 nat. Gr.

Fig. 5.

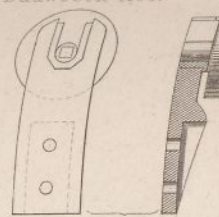

Fig. 6.

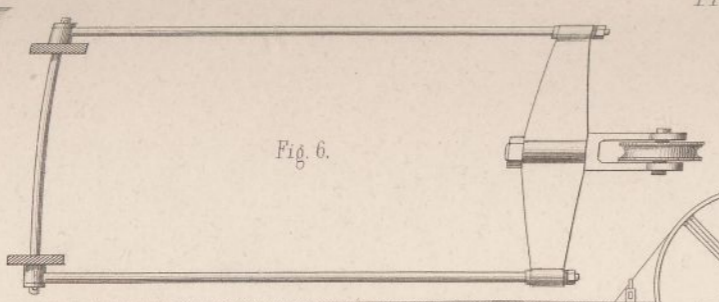

Fig. 7.



Fig. 8.

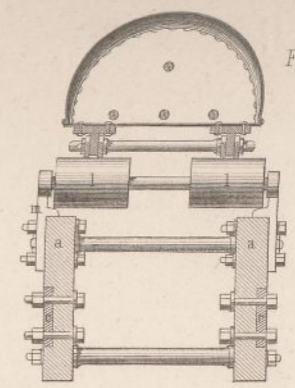

Fig. 9.

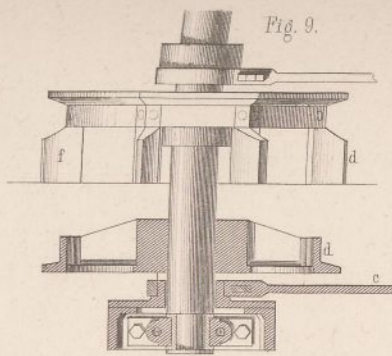

Fig. 10.

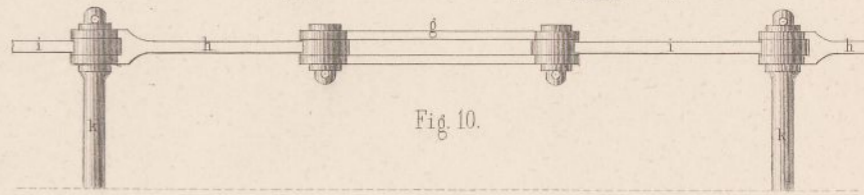

Fig. 3.

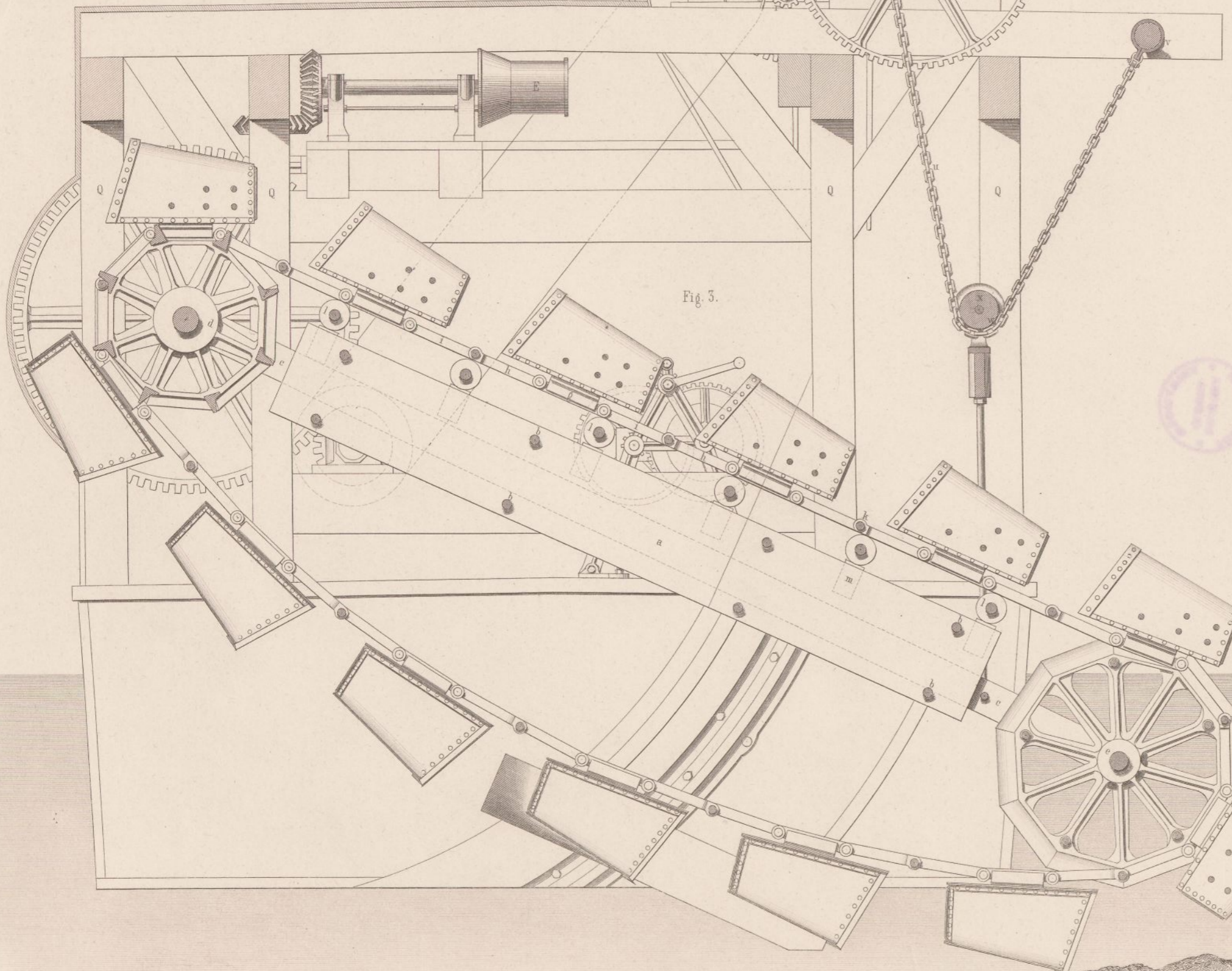

Fig. 4.

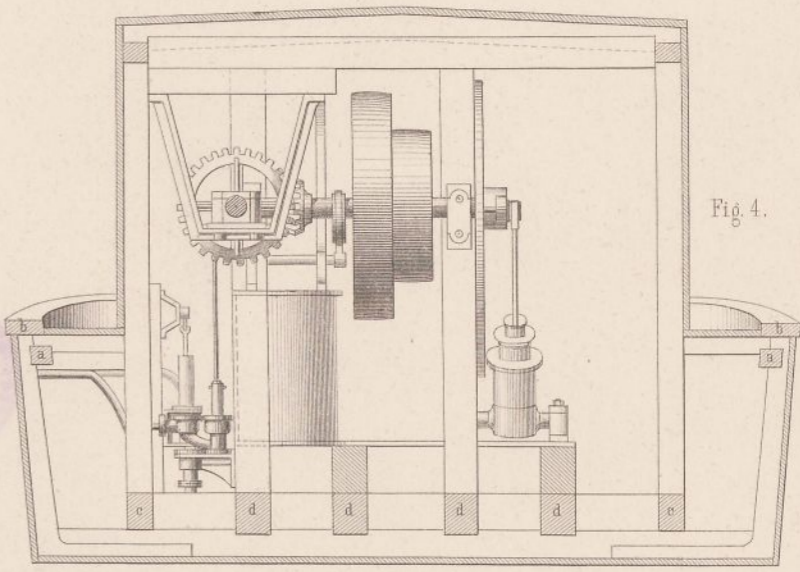

Fig. 11.

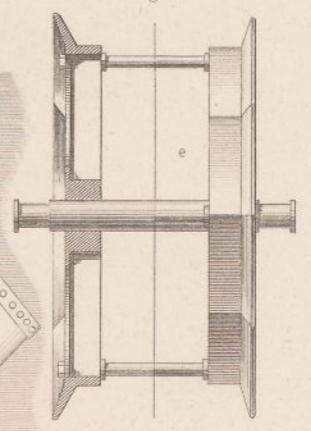
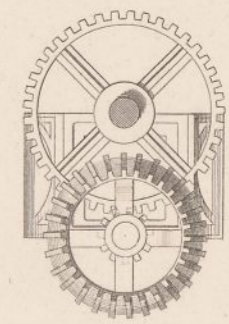
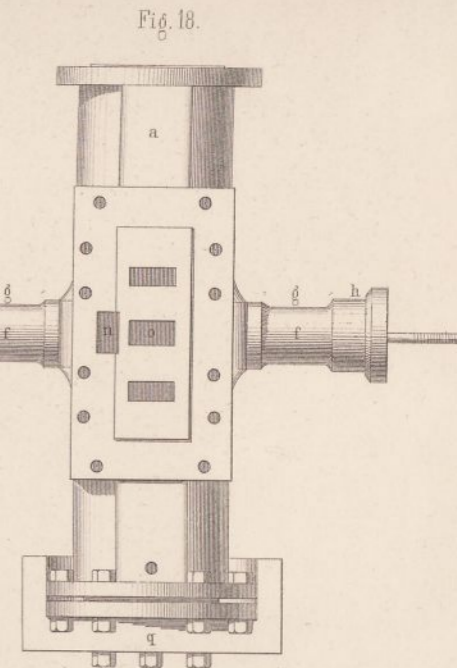
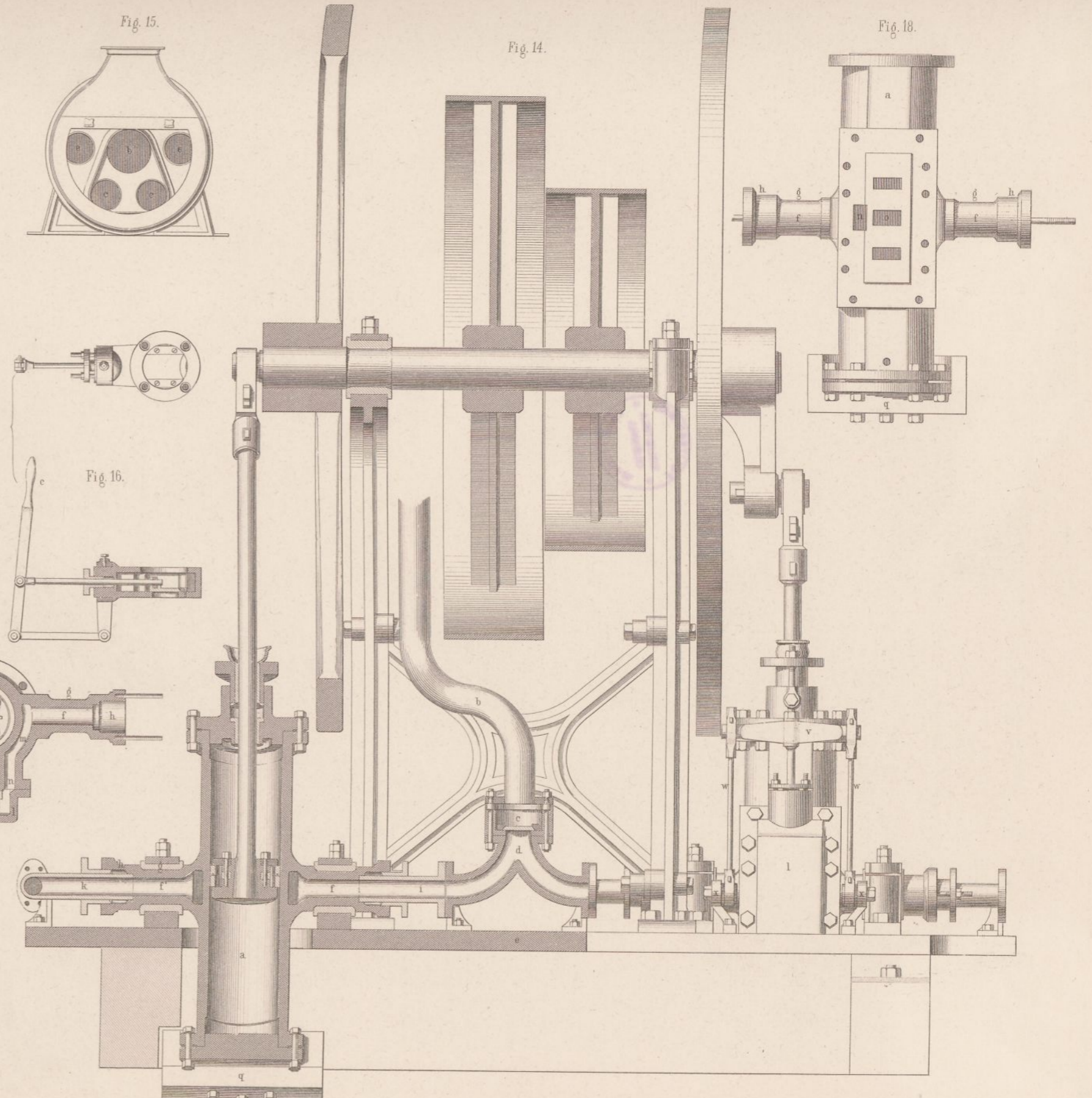
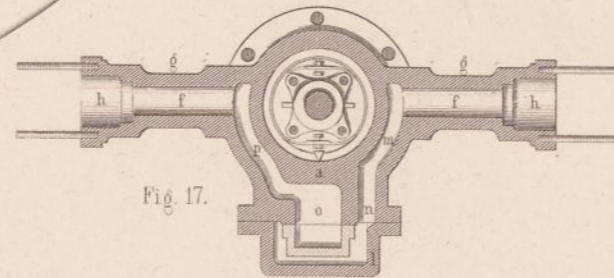
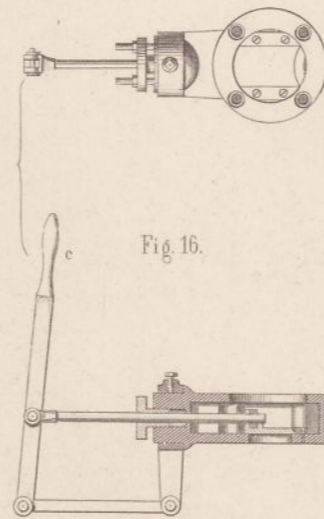
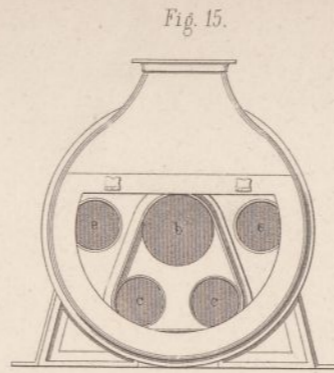
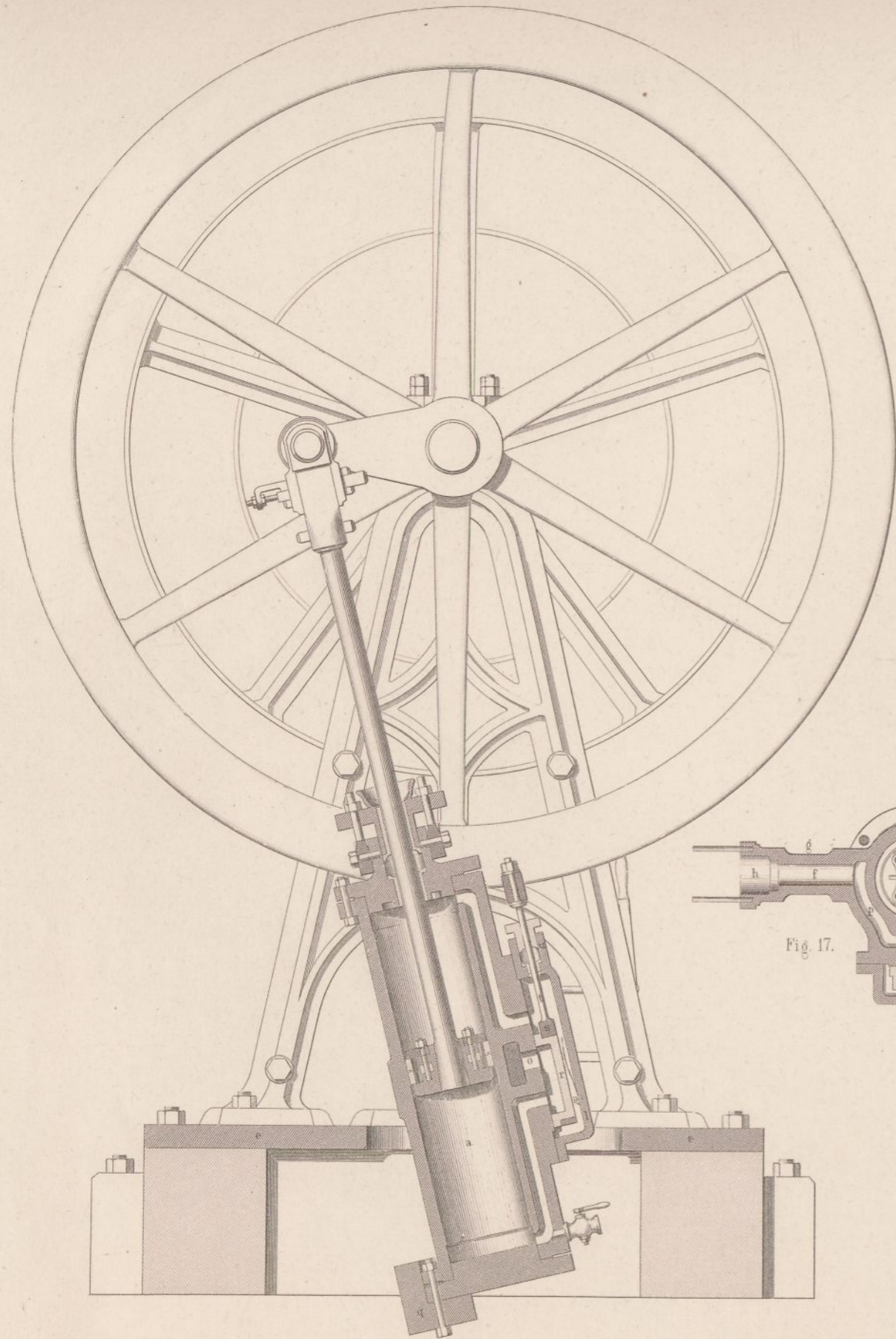
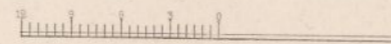

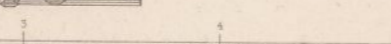

Fig. 12.







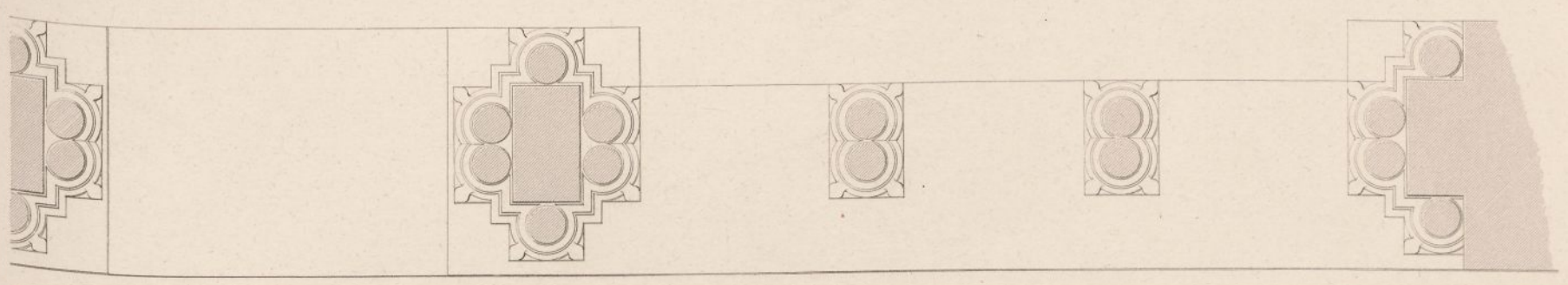
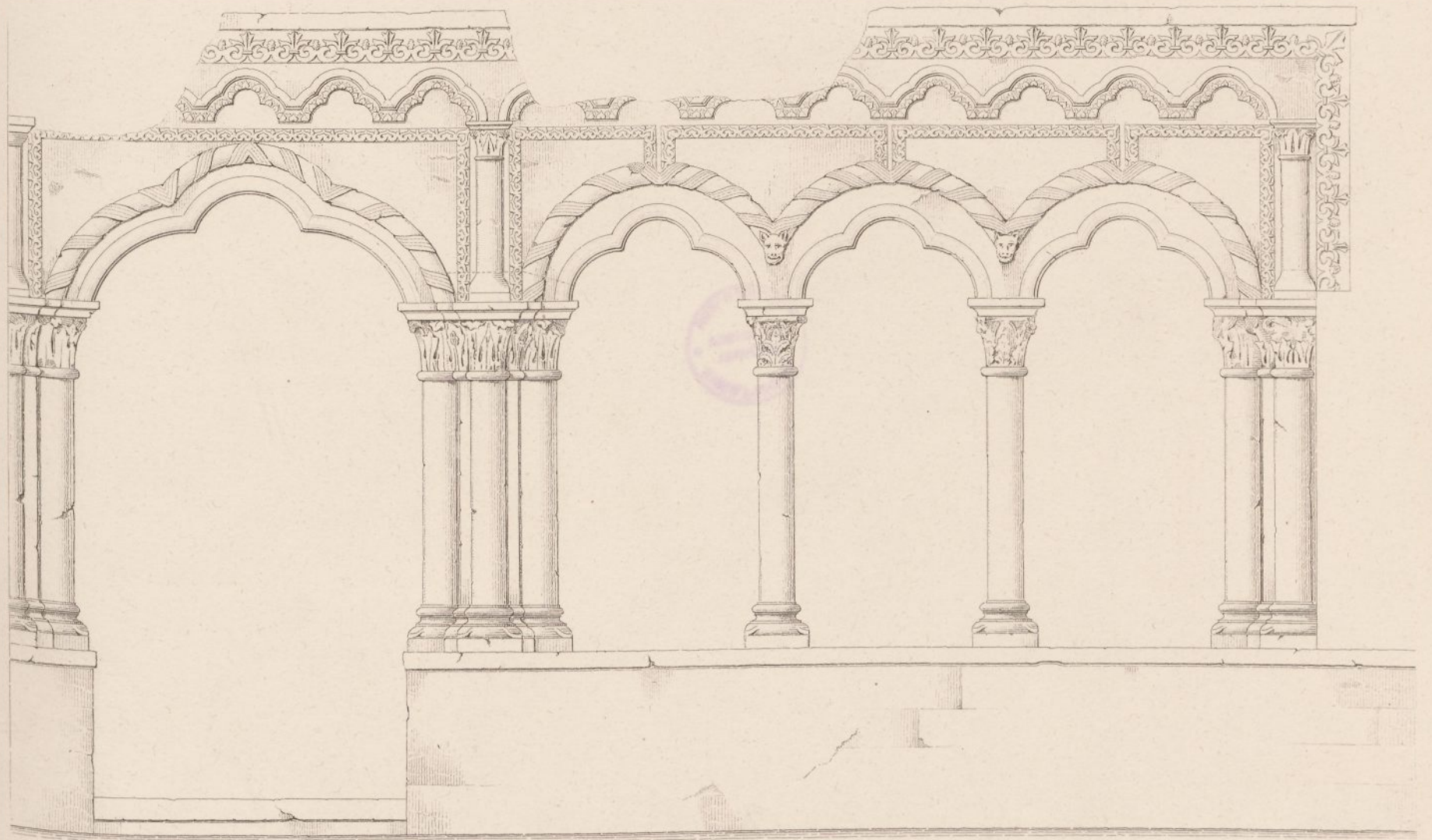

 5 Fuss rh-<sup>1</sup>/<sub>4</sub> nat. Gr.

Details aus dem Kreuzgang des Domes zu Aachen.

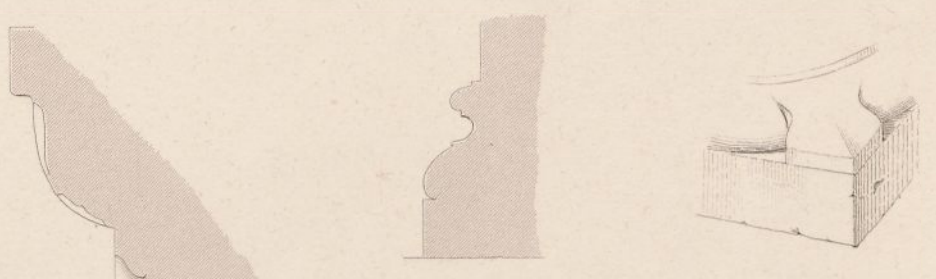

Profil u. Eckblätter der Basen.



Profil nach AB.

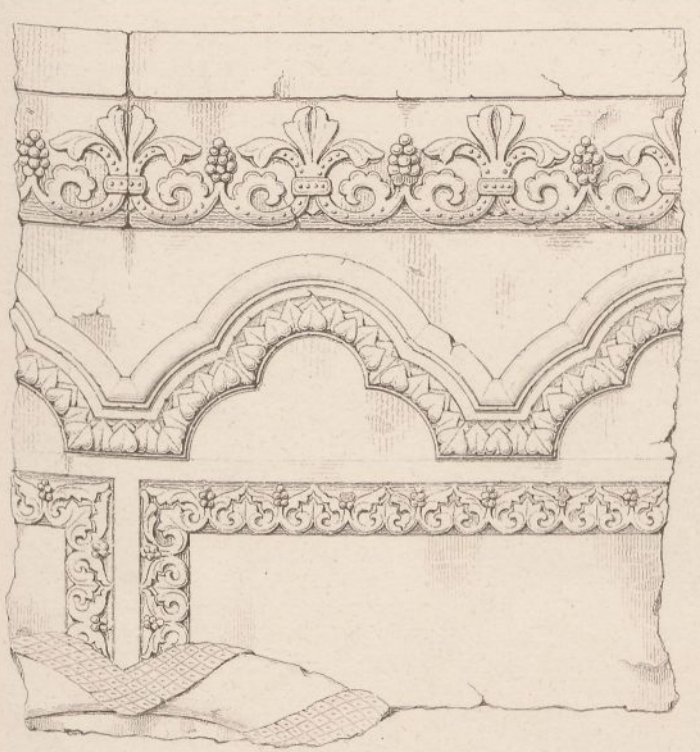
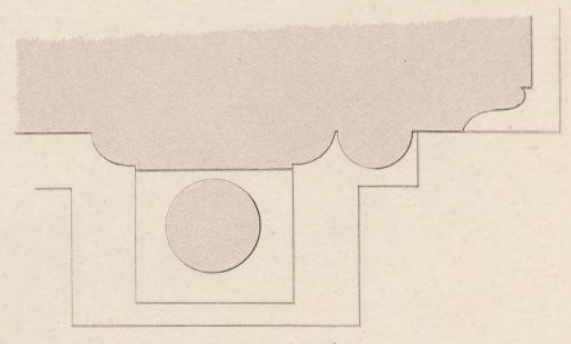



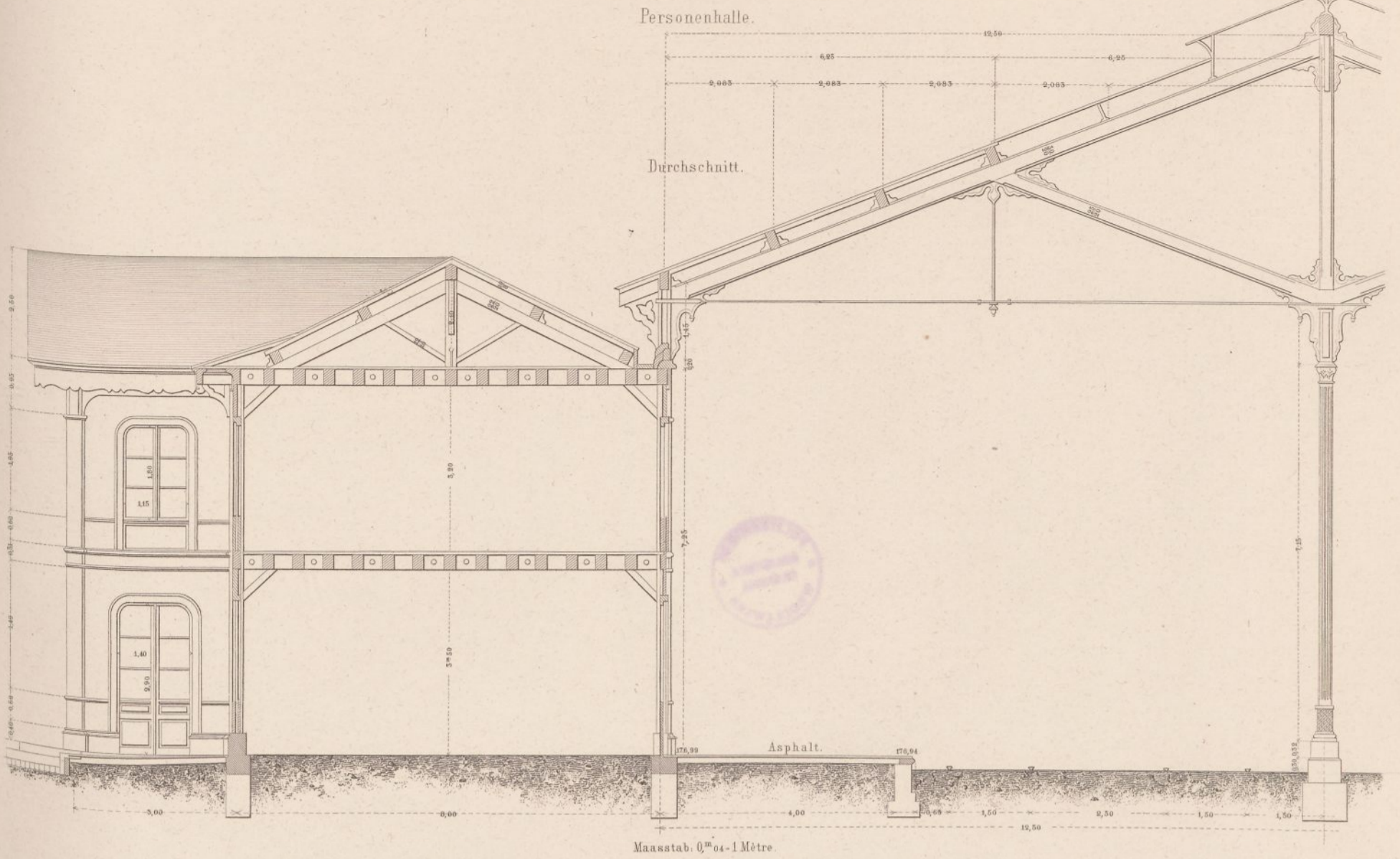

Grundriss des Empfangsgebäudes.

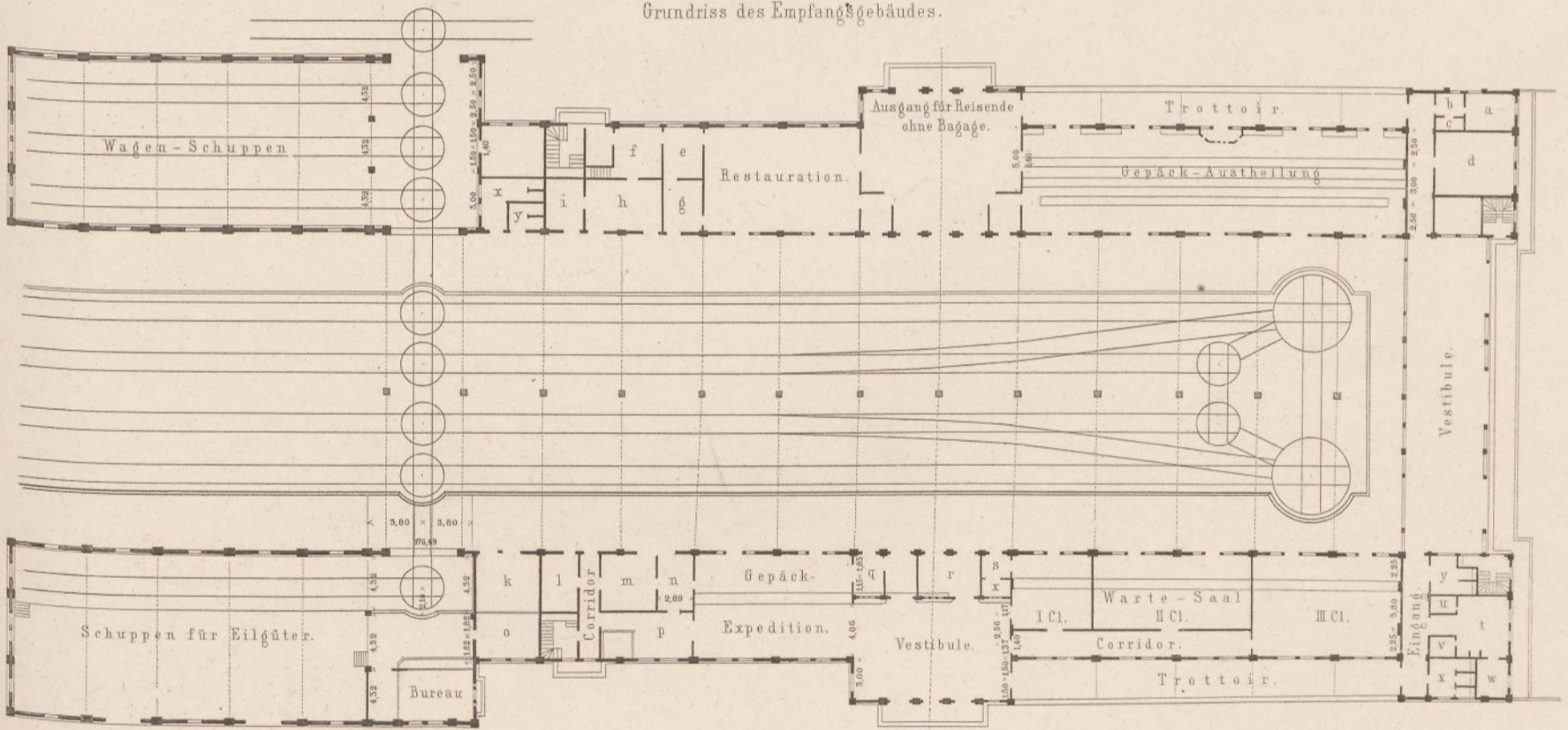

- a. Zimmer des Staats-Commissairs.
- b. Verzimmer.
- c. Cabinet.
- d. Bureau.
- e. Speisekammer.
- f. Küche.
- g. Kleiner Salon.
- h. Buffet.
- i. Zimmer des Restaurateurs.
- k. Zimmer für den Zugführer.
- l. Telegraph.
- m. Bahnhofs-Vorsteher.
- n. Bahnhofs-Assistent.
- o. Magazin f. aufgefundenen Sachen.
- p. Zimmer f. Bahnhofs-pp. Arbeiter.
- q. Gepäckraum.

- r. Billet-Ausgabe.
- s. Kleiner Salon.
- t. Portier.
- u. Alcoven.
- v. Kammer.
- w. Cabinet.
- x. Retirade für Männer.
- y. Retirade für Frauen.

Situation des Bahnhofes.

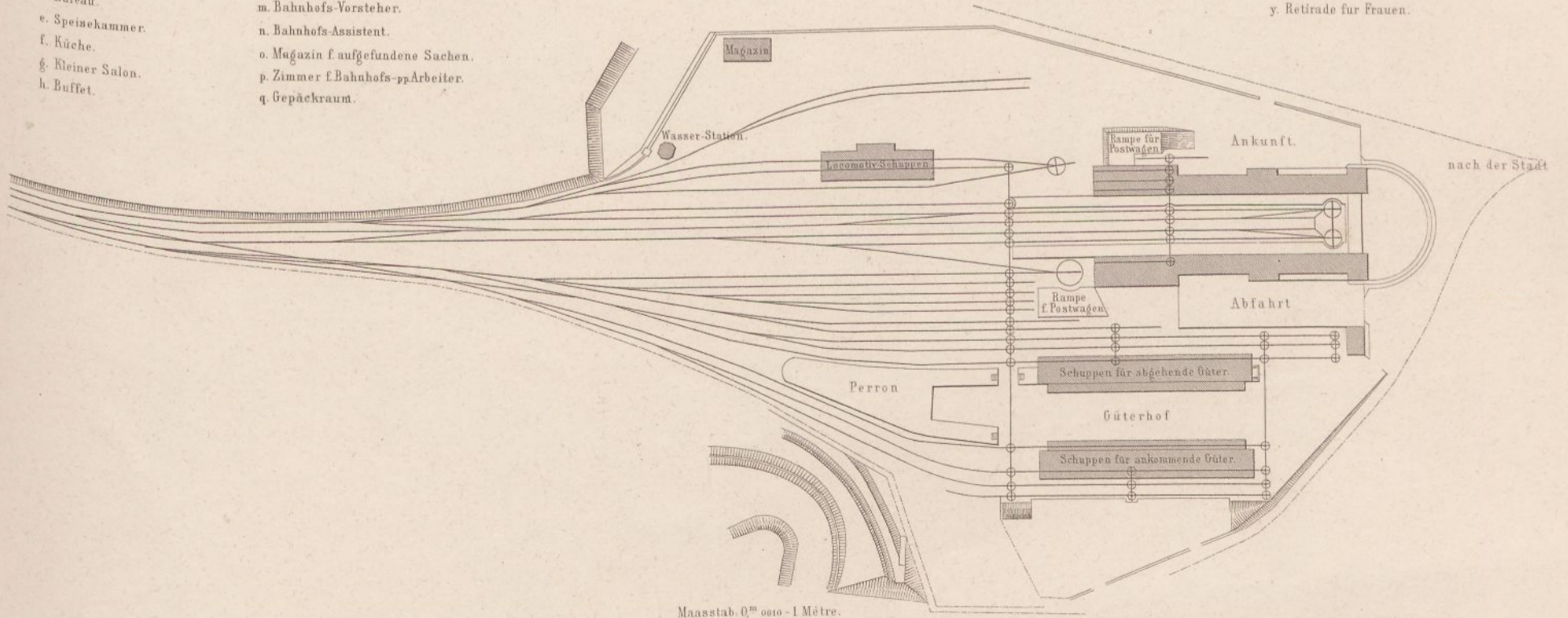

Gerüst-Hammer durch Riemscheibe bewegt  
von 1,8 Ctr. Gewicht mit Gummi-Federn.  
(190 Schläge in der Minute)

Querdurchschnitt nach A B.

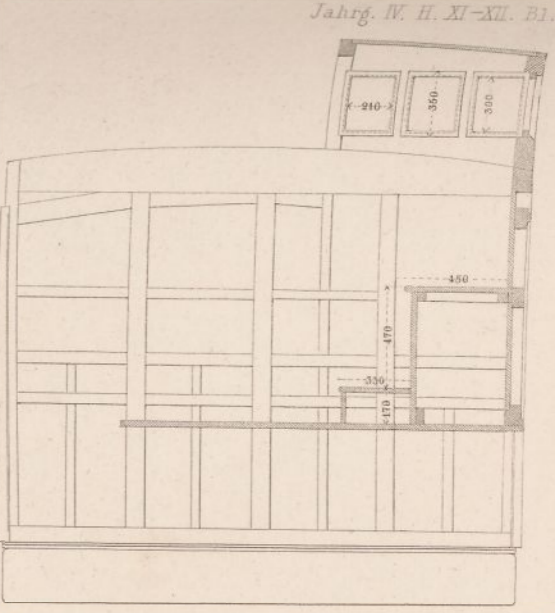
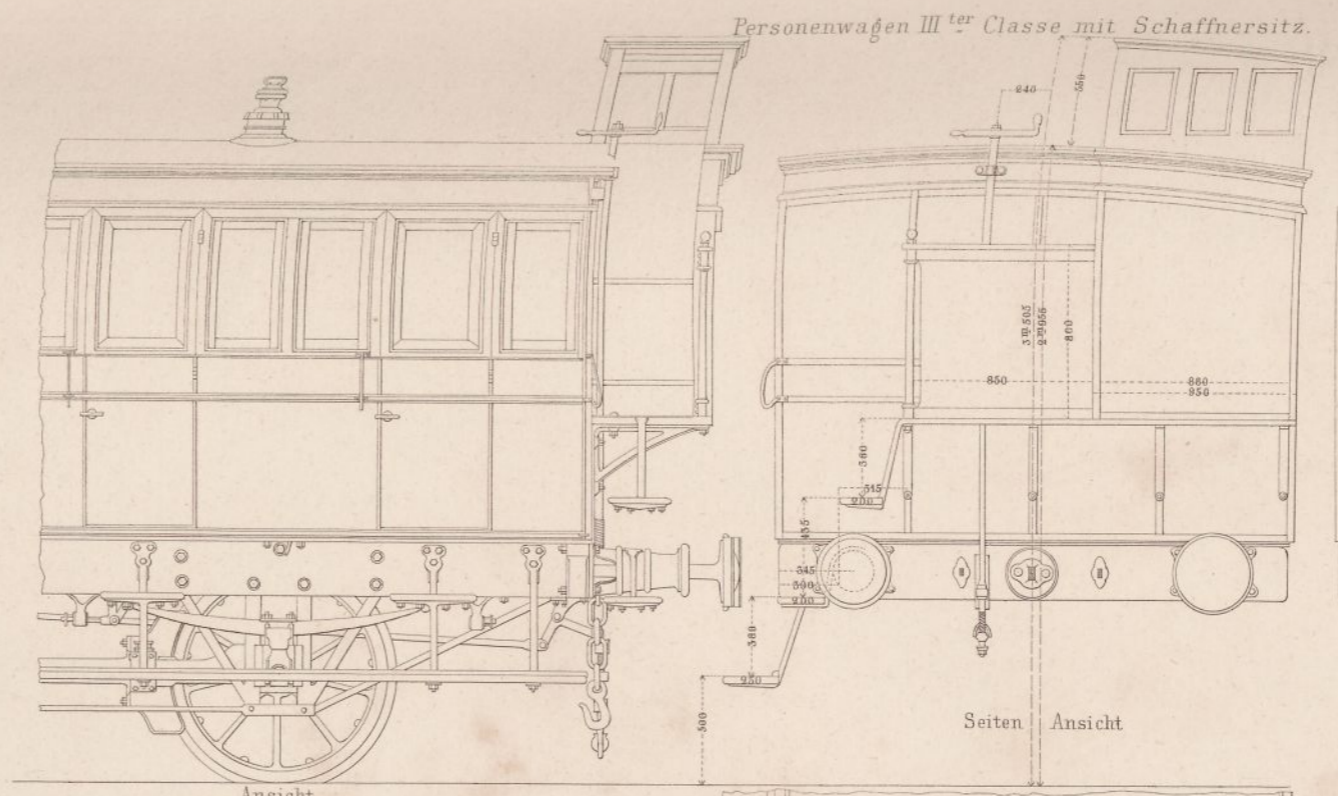
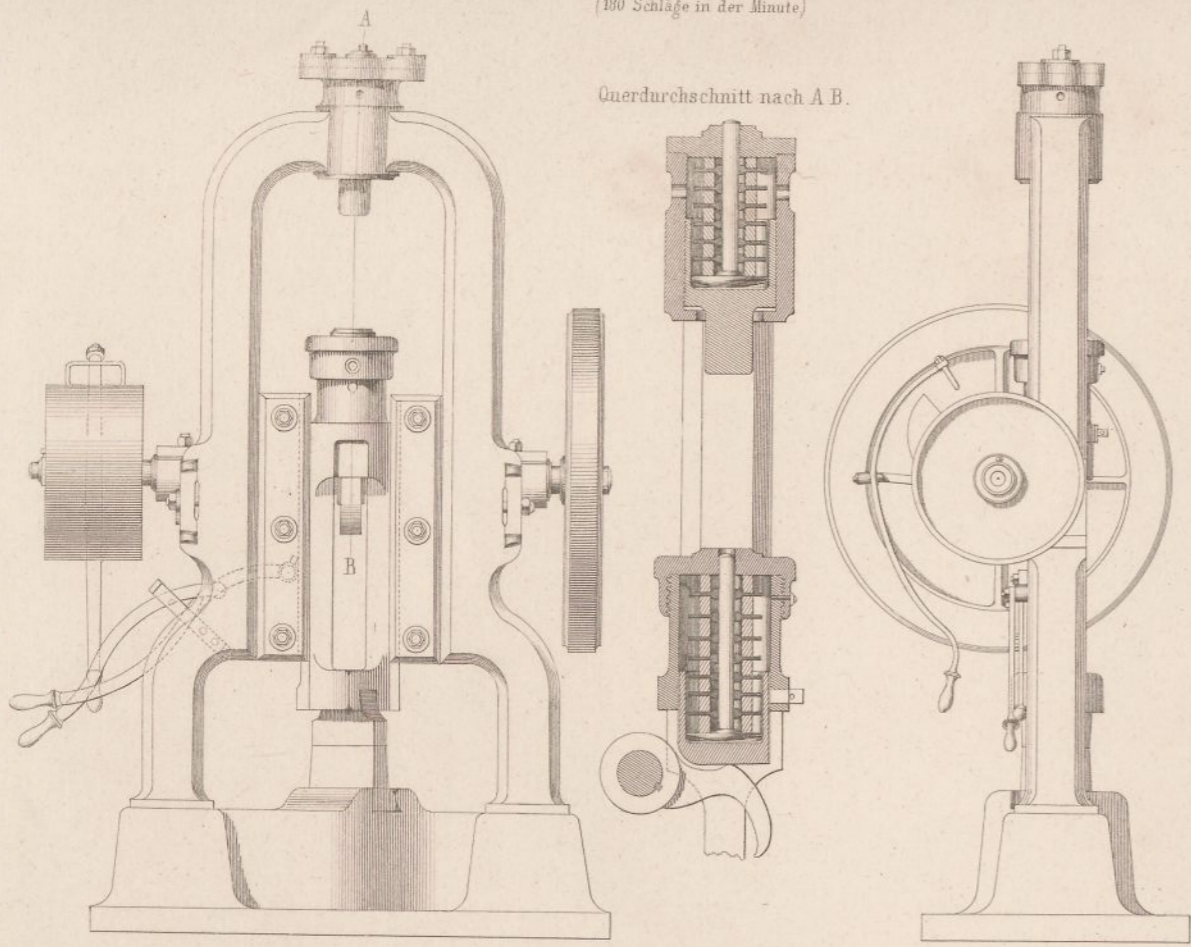

Seiten Ansicht

Holzconstruction

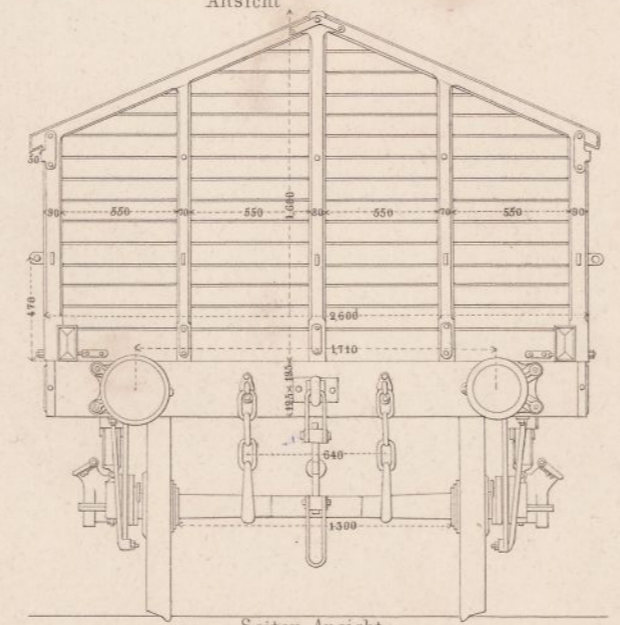

Ansicht

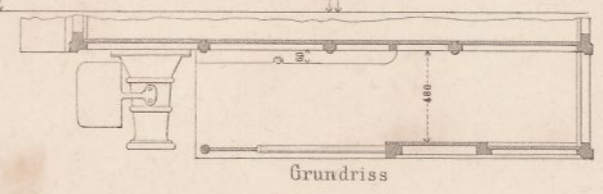

Grundriss

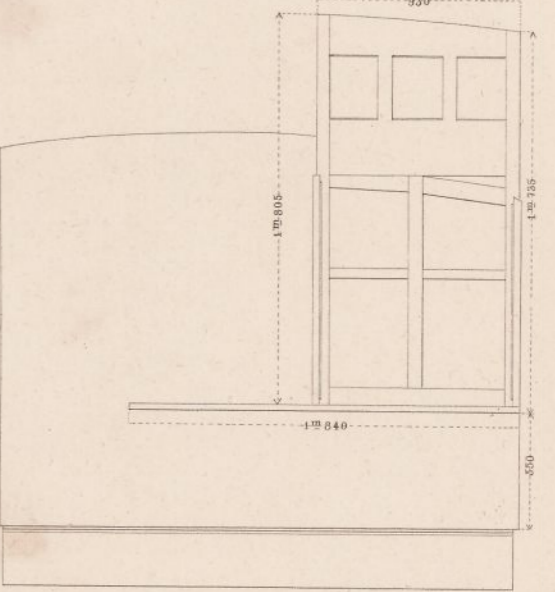

Bordwagen mit Klappen zum Kohlen und Güter Transport.

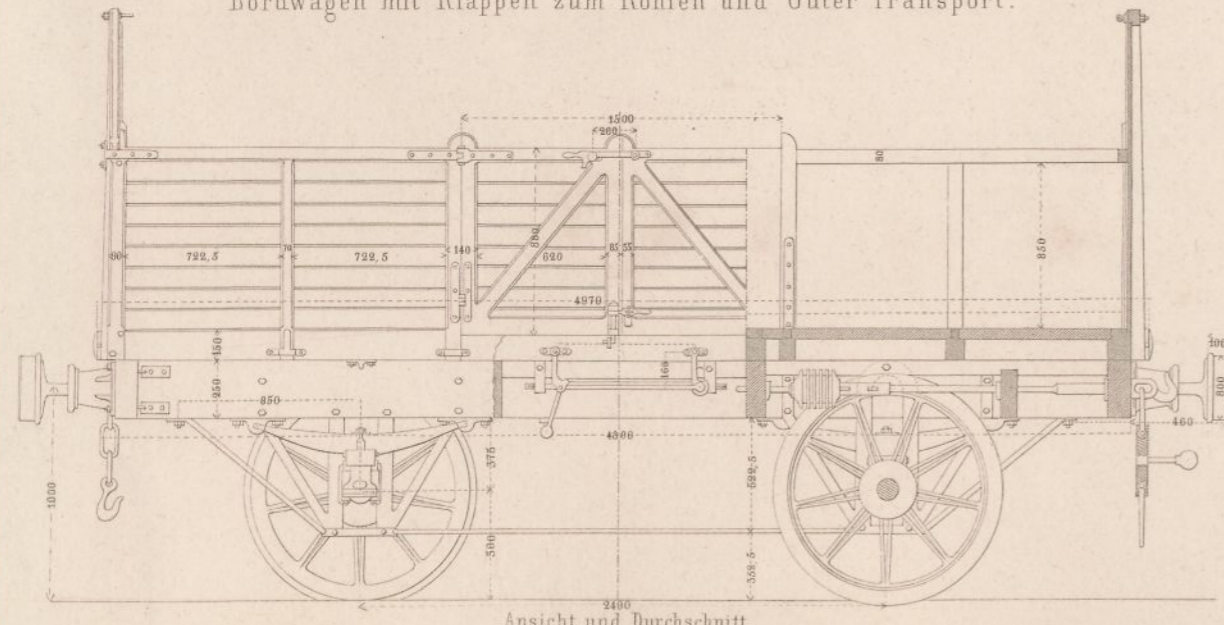

Ansicht und Durchschnitt.

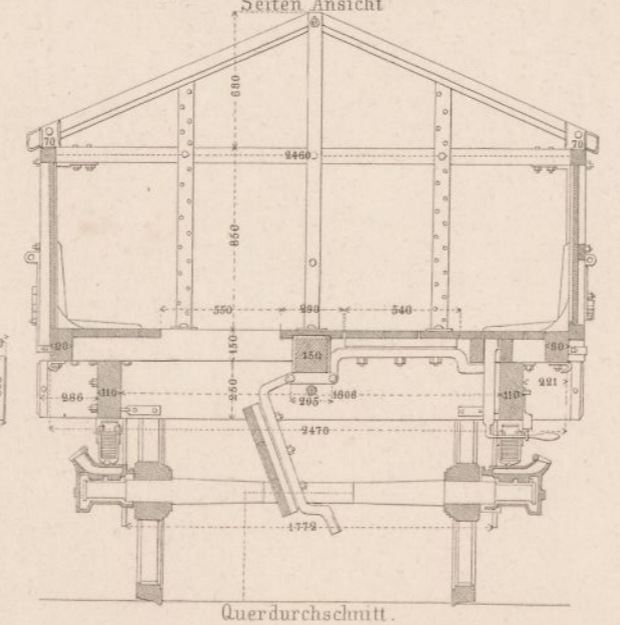

Querdurchschnitt.

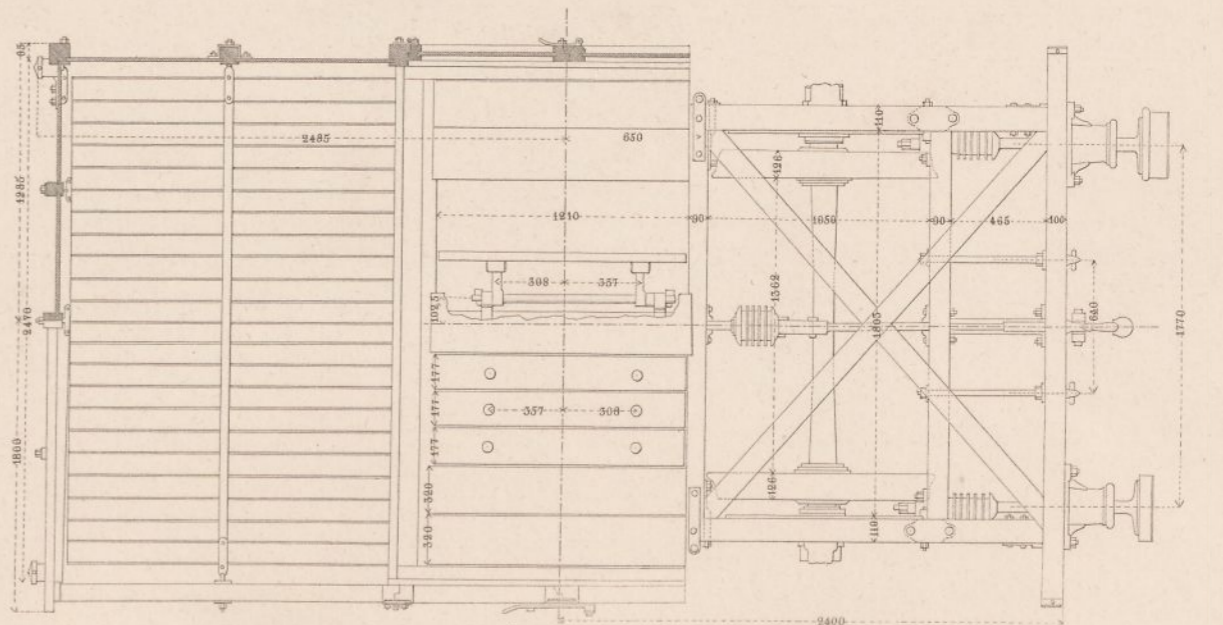

Grundriss.

Die Zahlen beziehen sich auf Millimetres.