

# **Transversely radio-frequency excited waveguide CO<sub>2</sub> laser\***

E. F. PLIŃSKI

Institute of Telecommunication and Acoustics, Technical University of Wrocław, Wybrzeże Wyspiańskiego 27, 50-370 Wrocław, Poland.

A RF waveguide CO<sub>2</sub> laser has been developed to produce 15.5 W of output. The results of experimental investigations and details for the design of the mechanical construction have been presented.

## **1. Introduction**

The radio-frequency longitudinal excitation was used very early in the first construction of a cw CO<sub>2</sub> laser [1], but later the method was passed over in favour of the dc excitation, more convenient in use from the point of view of matching the power supply to the laser channel [2]. The radio-frequency in transverse excitation of a waveguide CO<sub>2</sub> laser was applied again in 1978 [3], [4].

The application of the radio-frequency in the excitation of the discharge in waveguide lasers has many advantages such as:

- low voltage operation with voltage less than 300 V;
- high overall efficiency due to absence of a resistance ballast where usually about half of the delivered power is wasted (supplying a laser without a resistance ballast is possible thanks to positive voltage-current characteristics of the RF discharge);
- possibilities to produce a modulated output through the direct modulation of the radio-frequency input power;
- excitation of electrodeless discharges and thus avoiding the sputtering of a cathode;
- small and compact construction (production of compact long-life sealed-off lasers is possible because bulk plasma processes in the RF discharges should be softer [5]–[7]);
- lack of cathode fall region, thanks to that it is possible to obtain high small-signal gain [8], [9] (in the dc waveguide lasers a significant part of the

---

\* The work was made during the research-fellowship at the Twente University of Technology, Department of Applied Physics, Quantum Electronics Group, Enschede, The Netherland.

delivered power to the laser channel is wasted in the cathode fall region and therefore efficiency of the laser is lower in comparison to the RF lasers, in addition to that the delivered power heats the gas mixture limiting the gain in the active laser region of the channel);

– reduced cataphoretic effect in these gas lasers where gas mixture is used.

From the constructing point of view the discharge usually takes place in a full ceramic channel or a mixed, metal-ceramic one, where both act as a capacitive ballast for an RF transmitter [3], [10]–[14]. A mechanical construction of an RF laser should fulfil some principal requirements like:

- i) ensuring a good electrical shielding of a radio-frequency electro-magnetic field,
  - ii) ensuring a high quality vacuum-tight isolation and purity of the laser chamber,
  - iii) spectral purity gas components should be used (the last two requirements appear to be a very important factor in achieving of a long life device with high output),
  - iv) ensuring an effective cooling of the laser,
  - v) laboratory model should be easy in disassembling and assembling to exchange quickly, and as often as is needed, optional elements of both the laser and matching circuit without damage of the device,
  - vi) matching circuit should be placed as close as possible to the laser channel to avoid parasite resistance, inductance and capacitance.
  - vii) optical resonator should be equipped with good quality hard windows, stable to heat due to expected high density energy inside of the waveguide channel.
- We tried to satisfy the above requirements in the construction of the laser.

## 2. Construction

An aluminium box formed a mechanical resonator of the laser and simultaneously served as a reservoir of a gas mixture. The waveguide with dimensions of  $2.25 \times 2.25 \times 370$  mm composed of two bars of alumina ceramic and two aluminium electrodes was mounted inside of the box between rails to locate the position of the channel exactly along the box axis (see Fig. 1). Such a mechanical system enabled us to remove the waveguide from the box to exchange both the equalizing coils and a matching coil very easily and then to return with the waveguide to the previous position without any accident detuning of one of the laser mirrors. To exchange the equalizing coils in a simple way they were ended with special miniature plugs. Suitable miniature sockets were fixed in pairs along both the top and bottom electrodes of the laser at every fourth cm (together 8 pairs). The last pairs were fixed 5 mm from each end of the channel. The center of the top laser electrode was connected to a matching circuit by means of the same kind of miniature plug and socket. The matching coil was placed inside of the aluminium box and was wound around a 2 cm long glass tube of 1 cm in diameter. The matching coil was connected directly to the top laser electrode and, from another side, through the special

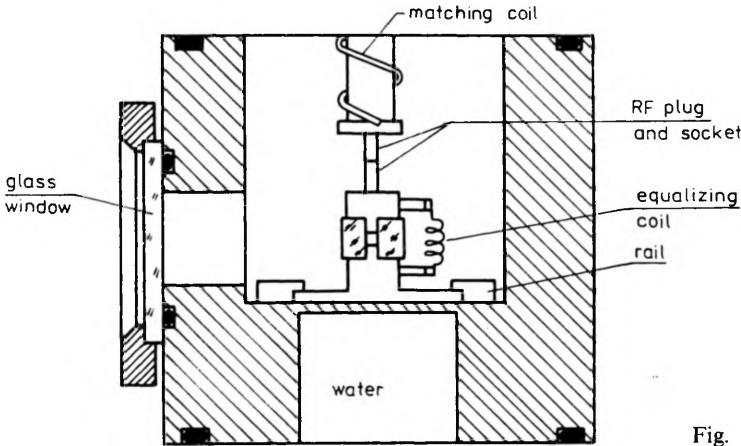

Fig. 1. Cross-section of the laser

home-made vacuum connection to a matching capacitor that was outside of the aluminium box (see Fig. 2). The matching air capacitor (with the maximum capacity of 120 pF) was put into a shielding house mounted on the removable top plate of the aluminium box. Other electrical devices as a reflectometer, an RF power preamplifier, an RF power amplifier and an RF generator, were connected to the matching circuit of the laser through a standard RF socket fixed on the shielding house.

The aluminium box was equipped with three panoramic holes (windows) cut out in one side wall giving full insight into the channel (see Fig. 1). Thanks to that, we could observe directly the channel side-light and control continuously the discharge behaviour. This constructing solution was very important because the vacuum-tight windows allowed visible estimating of the discharge homogeneity while the laser was running. The opposite side wall of the box was equipped with a connector pipe to pump and fill the laser with a gas mixture.

From the bottom side the aluminium box was hollow to permit water cooling of the waveguide, exactly its bottom electrode which was quiet enough to cool the laser.

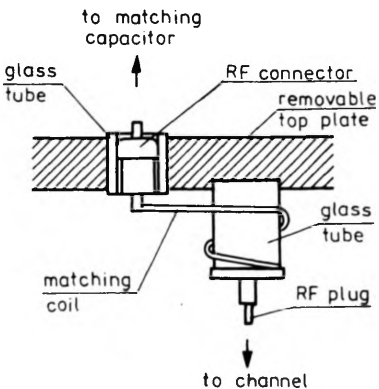

Fig. 2. Manner of the laser channel connection to the matching circuit

The reservoir was closed with a bottom plate of the box. Water was flowing through the reservoir while the laser was working.

Both ends of the box were ended with mirror heads (see Fig. 3). The mirror heads supported the laser mirrors in the actual position on the waveguide axis and on the actual distance from the channel outputs and simultaneously enabled us to detune the mirror precisely. To avoid diffraction losses we placed mirrors as closely as possible to the channel outputs, which means about 1.5 mm from each end of the

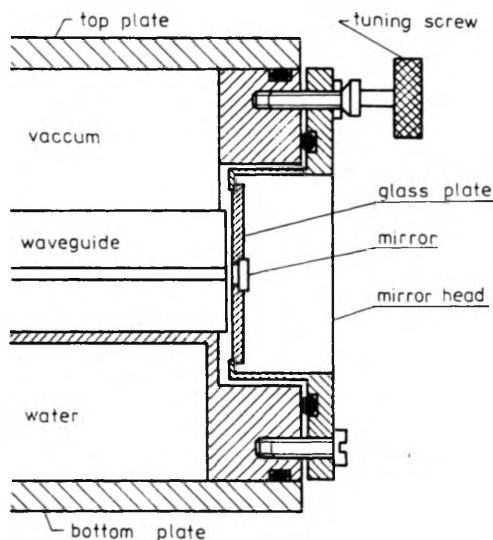

Fig. 3. Mirror head of the laser

waveguide. However, so small a distance could have caused a short circuit between the top and bottom electrode of the waveguide along the front surface of the mirror head. Therefore, we used a thin glass isolating plate, as a front surface of the head, and glued mirrors on it. This construction ensured a safe ignition of the discharge in the channel. We used a gold coated silicon mirror as a total reflecting one and a 92% reflectivity zinc-selenide mirror as an output one.

An alignment of the laser appeared very easy and we carried it out using a conventional He-Ne laser without any additional optical arrangement. Moreover, even with the working laser any additional alignment was not necessary.

The device was pumped and filled with a glass, good quality, vacuum apparatus by means of which it was possible to pump the laser to  $10^{-6}$  Torr of pressure. The laser was filled with spectral pure gases.

### 3. Experiment

We started with the experiment of investigating the voltage distribution along the laser channel, which seemed to be most important for the further part of the experiment, and most attention we devoted to it.

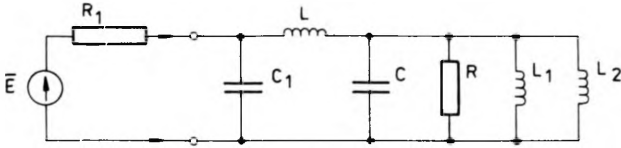

Fig. 4. Equivalent electrical set-up of the waveguide and a supply source  $\bar{E}$  with its resistivity  $R_1$ ,  $R$  – resistance of the plasma,  $C$  – capacitance of the waveguide,  $L$  – matching coil,  $L_1, L_2$  – equalizing coils

A voltage was delivered from a generator to the center of the laser channel through the capacitor  $C_1$  and inductor  $L$  (see the equivalent electrical set-up of the laser in Fig. 4). The measurements of the voltage in the center of the channel and in 8 regularly distributed points in the form of small holes placed on both sides of the channel were performed by means of special low capacity and high resistivity RF probe.

The curves representing the voltage distribution along the constructed waveguide laser channel, at a delivered frequency of 105 MHz without any equalizing coils connected to the ends of the channel, we can see in Fig. 5. The characteristics have been plotted at two load resistors  $2 \times 220 \Omega$  of low inductivity connected parallelly in the center of both the left and right arm of the channel simulating a plasma resistance. As it is seen in the picture, the voltage distribution at such a high frequency is very inhomogeneous, more than 40%.

According to the theoretical considerations in [15] and [16], to equalize the voltage distribution we used inductive coils in the experiment. The coils were made of a silver coated wire of 0.5 mm in diameter. In Fig. 6 we demonstrate the results obtained using four equalizing coils: two coils in each end of the channel, exactly 5 mm from both ends ( $8_R$  and  $8_L$  points on the channel) and with two additional coils in the center of each arm of the channel ( $4_R$  and  $4_L$  points). As it is seen in the picture, in the case of the application of two coils the homogeneity of the voltage was improved to 6%. For four coils we obtained even better than 2.5% of the homogeneity. The coils in  $8_R$  and  $8_L$  points were made of 8 turns of the silver wire of

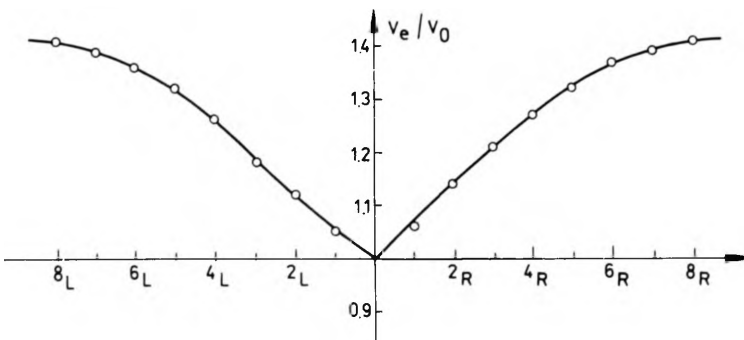

Fig. 5. Voltage distribution ( $f = 105$  MHz) along the cold laser channel without equalizing coils,  $V_0, V_e$  voltage in the center and in the measured points, respectively

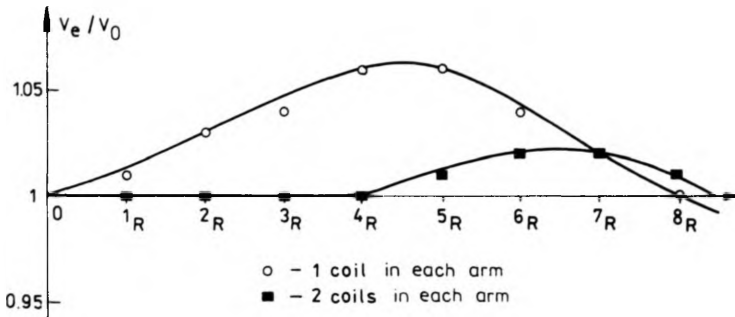

Fig. 6. Voltage distribution ( $f = 105$  MHz) along the right arm of the cold channel with one coil at the ends of the channel placed in  $8_R$  and  $8_L$  points (higher curve) and with two coils in each arm placed in  $8_R$ ,  $4_R$ ,  $4_L$  and  $8_L$  points (lower curve)

0.5 mm in diameter creating coils of 2 mm in diameter and 5 mm long. The coils in  $4_R$  and  $4_L$  points were made of 4 turns and were 3 mm long of the same diameter.

From the theoretical considerations in [16], it results that the voltage distribution in a cold channel should be almost the same as in the case of a hot one, this means while the laser is running. As it results from our experiment, it is true, but only to some extent. Let us look at Fig. 7. The characteristics were plotted for four equalizing coils as above and with (2) and without (1) load resistors. As it is shown in the picture, the characteristics taken with the load resistors lie lower than the characteristics taken without load resistors. It means that the laser plasma with its resistance can influence the discharge homogeneity in the waveguide channel.

Another result is shown in Fig. 8. Behaviour of the voltage distribution along the laser channel for different values of the supplying voltage has been examined. As it is seen, also the level of the input power can play a significant role in the field distribution along a waveguide. We confirmed the last result with the running laser.

Manipulations with one side of the channel do not remain without influence on the other side. Both arms of the channel are not independent. Let us look at Fig. 9 and take into account the characteristics on the right arm of the channel. The characteristics lie lower and lower for the decreasing value of the coil inductivity

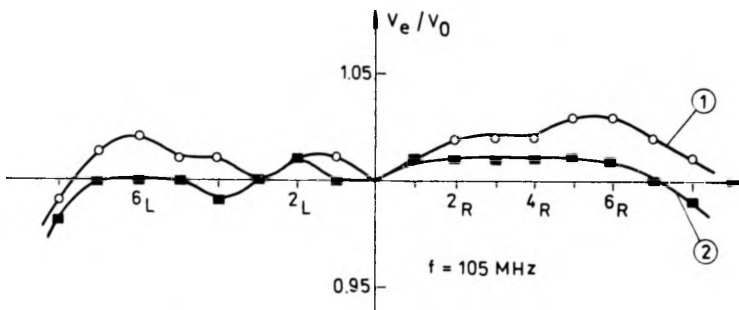

Fig. 7. Voltage distribution along the cold laser channel with four equalizing coils and: without the load resistors (1), with one load resistor of  $220 \Omega$  in the center of each arm of the channel (2)

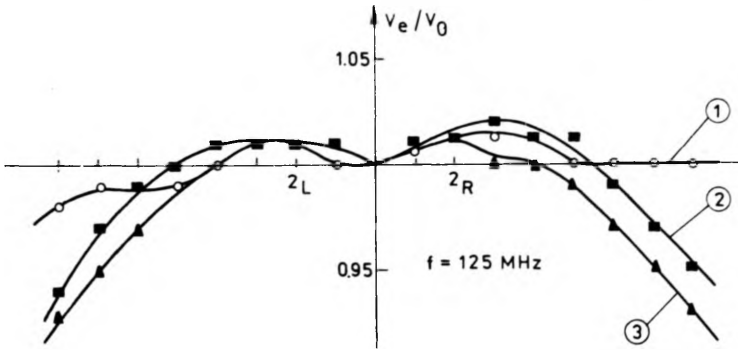

Fig. 8. Voltage distribution along the cold channel with four equalizing coils plotted for the supplying voltage of: 72.8 mV (1), 9.64 V (2), and 28.6 V (3)

which is obvious because of lower impedance of the coils. Simultaneously with the drop of the curves on the right side of the channel we can observe the rise of the curves on the opposite side. This information we should take into account while designing the laser. Finally, we established the inductivity of the coils experimentally.

We run the constructed laser at a frequency of 125 MHz and at a low pressure of 25 Torr at a composition of the gas mixture of CO<sub>2</sub>:N<sub>2</sub>:He = 1:1:3, 1:1.5:3 and 1:2:3 plus 5% of xenon. At the beginning we used one equalizing coil at each arm of the channel giving the voltage distribution as in Fig. 6. According to results shown in Fig. 8 we should expect a lower voltage at the ends of the channel than in the center when the laser is running. Indeed, dark regions visible through the ceramic plates in both ends of the channel were observed. It meant that the inductivity of the used coils (6 turns of the silver wire) was too low. Then, we added about half of a turn to each coil. The voltage distribution obtained after the modification was as in Fig. 10. In

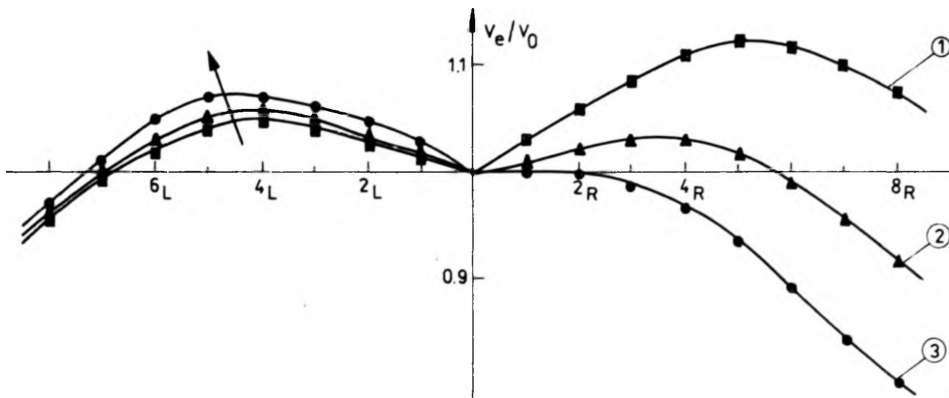

Fig. 9. Voltage distribution ( $f = 125 \text{ MHz}$ ) along the cold channel at 8 turns of the left coil and for different numbers of turns of the coil in the right end of the waveguide: 10 turns (1), 6 turns (2), and 4 turns (3)

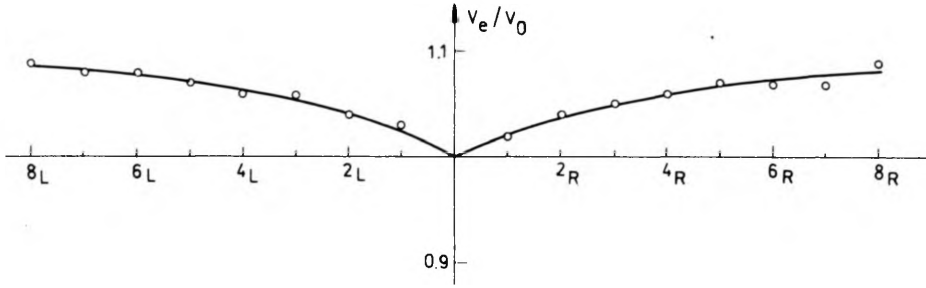

Fig. 10. Voltage distribution along the cold channel with two equalizing coils that we applied running the constructed laser at a frequency of 125 MHz

such a configuration the glow discharge was homogeneously distributed along the laser channel.

The characteristics of the output power and the efficiency of the laser versus the input power obtained are shown in Fig. 11, for different compositions of the gas mixture. As it results from the picture, the maximum of the laser efficiency translates into the higher value of the input power with the increase of the nitrogen amount in the gas mixture, but it remains constant in its value.

We have another situation at the pressure of 39 Torr (see Fig. 12) with the larger

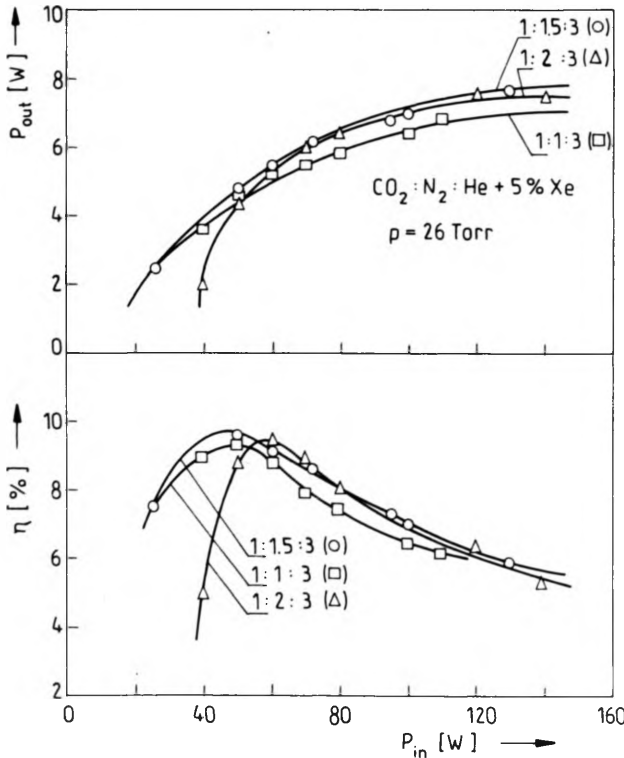

Fig. 11. Characteristics of the output power and the efficiency of the laser versus the input power for three different compositions of the gas mixture



amount of helium. The efficiency increases with the increase of the nitrogen amount but for the same level of the input power.

For the pressure of 26 Torr, we obtained the best efficiency of more than 9% at the input power of about 50–60 W. The best result in the output power, which means about 7.5 W, we achieved for all three gas compositions that we used but at a much lower efficiency of about 5–6%.

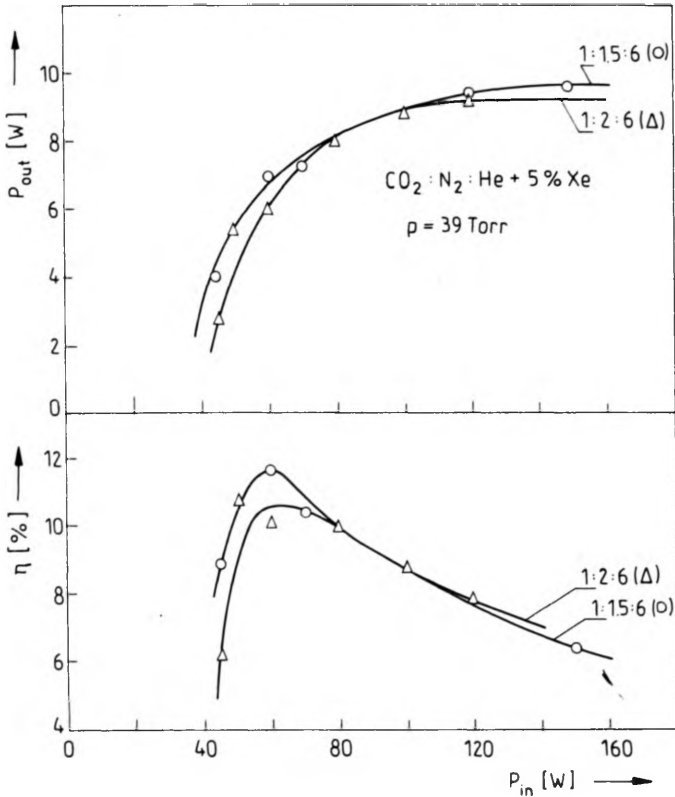

Fig. 12. Output power and the efficiency for two compositions of the gas mixture

We obtained better efficiency at the pressure of 39 Torr with the larger amount of helium, it is about 11% at the input power of about 60 W. The highest output that we achieved at that pressure, more than 9 W, was at the efficiency of about 7%.

The best results at the pressure of 47 Torr we obtained at the composition of the gas mixture of 1:1:3+5% Xe (see Fig. 13). The highest efficiency of about 12% we achieved at about 12 W of the output power. The highest output of 15.5 W we achieved at the efficiency of about 8%. To compare the results additionally, we placed in the picture the curves  $P_{out}(P_{in})$  and  $\eta(P_{in})$  that we obtained at the pressure of 26 Torr at the same composition.

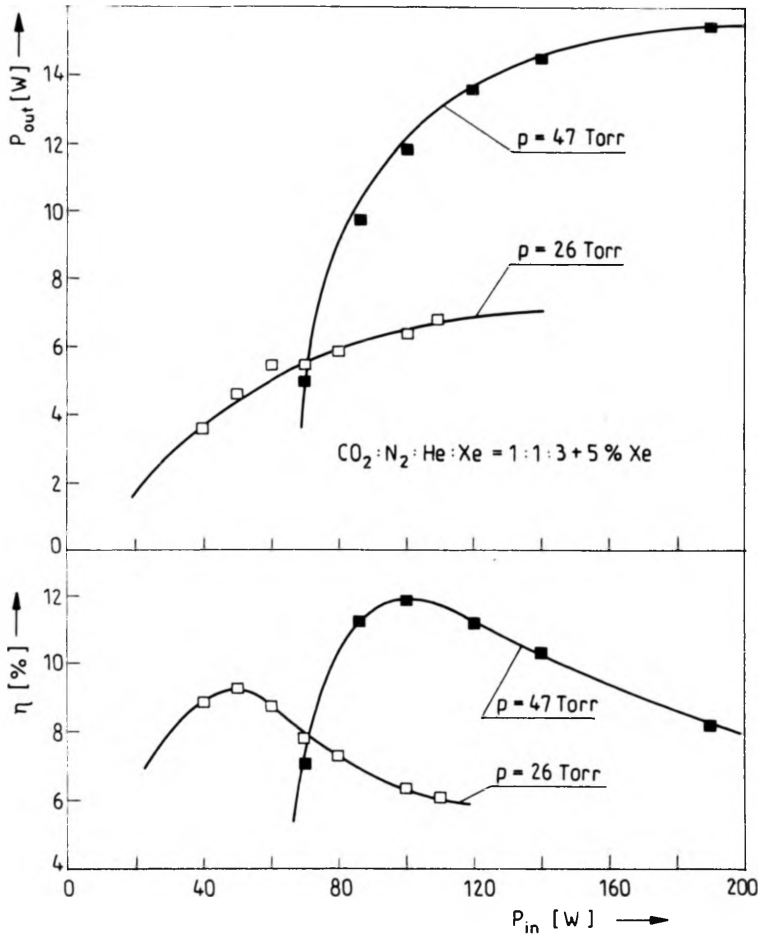

Fig. 13. Output power and the efficiency of the laser

#### 4. Conclusions

Considering the behaviour of both characteristics shown in the last picture, we can expect that the efficiency of the laser will rise with an increase of the total pressure and will translate into a higher value of an input power, which conclusion is very hopeful for further investigations on the constructed laser.

To sum up our experimental results, it is obvious that it is possible to get a higher efficiency and output from the laser by the conservation of the requirements mentioned in Sect. 1. However, it is necessary to apply a good power amplifier to avoid any limitations in the input power.

The subject touched in the work is the rapidly developing discipline of the laser technics in the last years. The interest in the radio-frequency excited  $CO_2$  waveguide lasers from the first one in 1978 [3], [4] is higher and higher and many studies are

devoted to them [17]–[38]. Recently, a new direction of the investigations on the subject has been opened: the lasers equipped with two or more waveguide channels placed parallelly along a common axis, the so-called laser arrays [39], [40].

*Acknowledgements* – The author owes a debt of gratitude to Professor W. J. Wittman who made it possible to carry out the experiment, and wishes to thank him for his encouragement. The author gratefully acknowledges the valuable assistance of A. B. M. Nieuwenhuis and H. Prins. The author's special thanks go to the secretary, Miss Simone Slot.

## References

- [1] PATEL C. K. N., *Phys. Rev. Lett.* **13** (1964), 617–619.
- [2] PATEL C. K. N., *Appl. Phys. Lett.* **7** (1965), 15–17.
- [3] LACHAMBRI J. L., MACFARIANE J., OTIS J., LAVIGNE G. P., *Appl. Phys. Lett.* **32** (1978), 652–653.
- [4] LAAKMAN K. D., *Proc. ICL*, Orlando 1978, p. 741–743.
- [5] LAAKMAN K. D., LAAKMAN P., *Proc. SPIE* **247** (1980), 74–78.
- [6] LAAKMAN K. D., *Proc. SPIE* **328** (1982), 2–6.
- [7] WILLIAMS G. C. R., SMITH A. L. S., *J. Phys. D: Appl. Phys.* **18** (1985), 335–346.
- [8] PAPAYOANOU A., *Appl. Phys. Lett.* **31** (1977), 736–737.
- [9] SMITH, P. W., MALONEY P. J., WOOD O. R., II, *Appl. Phys. Lett.* **31** (1977), 738–740.
- [10] SINCLAIR R. L., TULIP J., *J. Appl. Phys.* **56** (1984), 2497–2501.
- [11] SUTTER L. V., *Opt. Eng.* **20** (1981), 769–771.
- [12] ALLCOCK G., HALL D. R., *Opt. Commun.* **37** (1981), 49–52.
- [13] SINCLAIR R. L., TULIP J., *Rev. Sci. Instrum.* **55** (1984), 1539–1541.
- [14] CHIEN K. R., PARAZZOLI C. G., *J. Quant. Electron.* **QE-22** (1986), 479–488.
- [15] SKILLING H. H., *Electric Transmission Lines*, McGraw-Hill Book Co., New York 1951, p. 61.
- [16] HE D., HALL D. R., *J. Appl. Phys.* **54** (1983), 4367–4373.
- [17] GRIFFITH G. A., *Proc. SPIE* **227** (1980), 6–11.
- [18] GRIFFITH G. A., *Proc. SPIE* **335** (1983), 69–71.
- [19] CHENUSKY P. P., HART R. A., NEWMAN L. A., HOFFMAN N. N., *CLEO*, Phoenix 1982, paper THN2, p. 88–90.
- [20] LOVOLD S., WANG G., *Appl. Phys. Lett.* **40** (1982), 13–15.
- [21] BAKEREV A. E., VASILENKO L. S., SKHIMNIKOV O. M., *Sov. J. Quantum. Electron.* **12** (1982), 1115–1116.
- [22] HE D., BAKER C. J., HALL D. R., *ICL*, Guangzhou 1983, China, p. 217.
- [23] HE D., BAKER C. J., HALL D. R., *CLEO*, Baltimore 1983, paper WO1, p. 128–130.
- [24] HE D., HALL D. R., *Appl. Phys. Lett.* **43** (1983), 726–728.
- [25] GROSSMAN J. G., CASPERSON L. W., STAFSUDD O. M., *Appl. Opt.* **22** (1983), 1298–1305.
- [26] HE D., HALL D. R., *IEEE J. Quant. Electron.* **20** (1984), 509–514.
- [27] HE D., BAKER C. J., HALL D. R., *J. Appl. Phys.* **55** (1984), 4120–4122.
- [28] DENNIS R. B., *Proc. SPIE* **492** (1985), 23–24.
- [29] LOVOLD S., WANG G., *IEEE J. Quant. Electron.* **20** (1984), 182–185.
- [30] MIRZAEV A. T., SHARAKHIMOV M. Sh., *Sov. J. Quantum. Electron.* **14** (1984), 832–835.
- [31] BAKER C. J., HALL D. R., DAVIES A. R., *J. Phys. D: Appl. Phys.* **17** (1984), 1597–1606.
- [32] CHIEN K. R., PARAZZOLI C. G., *CLEO*, Malvern 1985, paper FN4, p. 296–297.
- [33] VIDAUD P., HE D., HALL D. R., *J. Appl. Lett.* **57** (1985), 1757–1758.
- [34] VIDAUD P., HE D., HALL D. R., *Opt. Commun.* **56** (1985), 185–190.
- [35] BOSCOLO L., BRUNETTI G., RAINO A., STAGNO V., *Opt. Commun.* **58** (1986), 35–38.
- [36] PARAZZOLI C. G., KUEI RU CHIEN, *IEEE J. Quant. Electron.* **22** (1986), 479–488.
- [37] XIN J. G., ALLCOCK G., HALL D. R., *J. Phys. D: Sci. Instrum.* **19** (1986), 210–212.

- [38] AKIHITO HONGO, MITSUNOBU MIYAGI, YOSHINIKO WAGATSUMA, SHIGEO NISHIDA, *CLEO*, San Francisco 1986, paper WF4, p. 164–165.
- [39] NEWMAN L. A., HART R. A., KENNEDY J. T., DEMARIA A. J., *CLEO*, San Francisco 1986, paper WF1, p. 162–164.
- [40] NEWMAN L. A., HART R. A., KENNEDY J. T., CANTOR A. J., DEMARIA A. J., BRIDGES W. B., *Appl. Phys. Lett.* **48** (1986), 1701–1703.

*Received June 20, 1988*  
*in revised form September 8, 1988*

### **Волноводный лазер CO<sub>2</sub> поперечно возбуждаемый радиочастотой**

Изложена конструкция лазера CO<sub>2</sub> выходной мощности 15,5 В, поперечно возбуждаемого радиочастотой. Описаны результаты экспериментальных исследований устройства и подробности его конструкции.