

JÓZEF DZIOPAK*

THE MATHEMATICAL MODELS FOR GRAVITATIONAL TWO-CHAMBER STORAGE RESERVOIR OF THE CONTRACT TYPE

The results of research presented in this paper have become the basis for hydraulic and mathematical models of designs proposed for multi-chamber reservoirs and for the theoretical principles of sizing them in a sewage system. In the results, variation over time and space in conditions of sewage inflow, storage and outflow from two-chamber storage reservoir type CONTRACT is taken into account.

DENOTATIONS

- AA – horizontal cross-sectional area of the storage chamber of a ZCC CONTRACT-type two-chamber reservoir, m^2 ;
 AK – horizontal cross-sectional area of a traditional reservoir operating in a gravitational system, m^2 ;
 AP – horizontal cross-sectional area of a flow chamber in a multi-chamber reservoir of ZCC type, m^2 ;
 b – length of overflow edge of multi-chamber reservoirs, m ;
 Ba – width of storage chamber AA of a ZCC two-chamber reservoir, m ;
 Bp – width of flow chamber in multi-chamber reservoirs, m ;
 Fzr – reduced urban drainage basin area, ha ;
 Fz – area of an aperture with flap valve, m^2 ;
 h – sewage fill height in a traditional reservoir or in the overflow chamber of a multi-chamber reservoir calculated from the outflow channel axis, m ;
 h_{max} – maximum fill height of a multi-chamber reservoir, m ;
 ha – overflow height from the bottom of the storage chamber in a ZCC two-chamber reservoir, m ;
 hc – sewage fill height in overflow chamber measured from overflow edge level during AA chamber filling in ZCC two-chamber reservoir, m ;
 hc_{max} – maximum sewage fill height above overflow during the filling of storage chamber and $hc_{max} = h_{max} - hp$, m ;
 hn – sewage fill height in storage chamber above ZCC reservoir overflow during submerged overflow operation, m ;

* Rzeszów University of Technology, 35-959 Rzeszów, ul. Powstańców Warszawy 6, Poland, Phone: 48 (17) 8651817; Fax: 48 (12) 6358952, 48 (17) 8651175; E-mail: jdziopak@prz.rzeszow.pl

- h_o – differences between sewage levels in chambers which ensure flap valve opening in ZCC two-chamber reservoir, corresponding to hydrostatic pressure differences, m;
- h_p – sewage fill height in overflow chamber measured from outflow channel axis to overflow edge position in ZCC two-chamber reservoir, m;
- h_{po} – instantaneous difference of sewage level between storage and overflow chambers or adjoining storage chambers and $h_{po} < h_o$, m;
- H, H_a – sewage height in ZCC reservoir storage chamber measured from outflow channel axis, m;
- H_o – difference in sewage levels in chambers taking account of the effect of partition on overflow discharge and $H_o > 0.005$ m, m;
- H_{rz} – difference in inflow and outflow bottom position ordinates in reservoir cross-section, m;
- H_u – average fill height storage chamber in ZCC two-chamber reservoir and $H_u = 0.5 h_i + h_{pr}$, m;
- dh – instantaneous change in sewage filling conventional reservoir or overflow chamber of a multi-chamber reservoir at time dt , m;
- dH – instantaneous change in sewage filling a storage chamber of a multi-chamber reservoir in question at time dt , m;
- l – length of discharge channel from reservoir, m;
- La – length of AA storage chamber in ZCC two-chamber reservoir, m;
- L_p – length of overflow chamber of multi-chamber reservoirs, m;
- QA – sewage inflow to reservoir, dm^3/s ;
- $QA(T_p)$ – maximum sewage inflow to reservoir from design storm for sizing the channels at $T_d = T_p$, dm^3/s ;
- $QA(TMW)$ – maximum sewage inflow to reservoir from design storm for sizing multi-chamber reservoirs at $T_d = TMW$, dm^3/s ;
- $QA(t)$ – instantaneous sewage flow in channel at time t , dm^3/s ;
- QA_i – discrete sequence of stormwater flow intensity of duration longer or equal to inflow time and $T_{di} \geq T_p$, dm^3/s ;
- QA_j – discrete sequence of stormwater flow intensity of duration shorter than inflow time and $T_{dj} < T_p$, dm^3/s ;
- QC – time-varying sewage flow from overflow chamber through overflow to storage chamber of ZCC two-chamber reservoir, dm^3/s ;
- QC_{\max} – maximum sewage flow through overflow of ZCC two-chamber reservoir, dm^3/s ;
- QC_n – sewage flow intensity through non-submerged overflow, dm^3/s ;
- QC_z – sewage flow intensity through submerged overflow, dm^3/s ;
- QK – sewage flow intensity through ZCC two-chamber reservoir flap valve opening, dm^3/s ;
- QKo – hydraulic efficiency of trunk sewer located behind outflow channel opening, dm^3/s ;
- QO – sewage runoff from reservoir, variable over time; dm^3/s ;
- QO_{\max} – maximum sewage outflow from reservoir, dm^3/s ;
- QP – sewage flow intensity via overflow from storage chamber to overflow chamber of ZCC two-chamber reservoir, dm^3/s ;
- tk – time of ground saturation for stormwater runoff, min;
- tr – stormwater runoff channel storage time, min;
- T_d – rainfall duration, taking into account the times of ground saturation and channel storage and $T_d = t_p + tk + tr$, min;
- T_{di} – discrete sequence of rainfalls with duration longer than or equal to inflow time and $T_{di} \geq T_p$, min;
- T_{dj} – discrete sequence of rainfalls with duration shorter than inflow time and $T_{dj} < T_p$, min;

- T_e – time after which reservoir is completely filled, corresponding to maximal sewage storage in reservoir, s;
- T_o – sewage storage time until the reservoir is completely emptied, s;
- T_p – rainfall duration equal to inflow from the furthest basin point used to size the system by the method of maximum intensity, min;
- TMC – design storm durations for sizing ZCC two-chamber reservoirs, min;
- VC – total capacity of ZCC two-chamber reservoir, m^3 ;
- c – frequency of design storm for the purpose of sizing the sewage system, years;
- c_z – frequency of design storm for the purpose of sizing the storage reservoir, years;
- $C_1, C_2, C_3, C_4, C_5, C_6, C_7, C_8$ and C_9 – constants of differential equations for sewage storage in multi-chamber reservoirs;
- Do – outflow channel diameter, m;
- g – acceleration of gravity, $m \cdot s^{-2}$;
- i_a – bottom slope of the storage chamber in ZCC two-chamber reservoir, %;
- Ko – parameter characterizing outflow channel hydraulic efficiency, called outflow parameter, $m^{2.5} s^{-1}$;
- n – exponent in formulae used to calculate design storm runoff to sewage system;
- n_o – roughness coefficient of outflow channel;
- n_r – coefficient of dilution by stormwater runoff at stormwater overflow;
- n_{r0} – coefficient of dilution by stormwater runoff at the last stormwater overflow;
- μ – sewage flow reduction factor in reservoir $\beta = QO \max \cdot QA(Tp)^{-1}$;
- μ – factor for groundwater runoff to sewage system;
- μ – factor for sewage runoff to outflow channel;
- μ_1 – factor for non-submerged overflow discharge;
- μ_2 – factor for submerged overflow discharge for non-submerged layer of sewage;
- μ_3 – factor for submerged overflow discharge for submerged layer of sewage.

1. INTRODUCTION

It has proved advantageous to divide a traditional reservoir into two main parts, each performing a different function, namely the control chamber and the space for storing excess sewage, which can be emptied during a drop in sewage inflow to the reservoir through a hole automatically regulated by a flap valve. This approach has also given rise to an interesting scientific problem.

In order to describe theoretically the sewage storage process in the physical reservoir models proposed, many partial mathematical models for each type of reservoir, i.e. ZCC, ZCX, ZCT and ZCW, at various stages of operation have to be formulated.

Determining the variation in flow balance in multi-chamber reservoirs and their efficiency in combination with the set of structural parameters under investigation, we ought to adopt an identical procedure for determining fluctuations in sewage flow over time. This was done on the basis of previous research [1]–[4] and the principles of the method of extreme intensities [2], [5], [6].

The models discussed here take into account the possibility of describing the storage phase for any given hydrograph and an arbitrary mathematical procedure of pre-

senting the outflow in the form of a function of flow fluctuation after transforming it into a sequence of elementary linear functions expressing the relationship between flow volume and time over a given time span.

2. DERIVING OF HYDROGRAPHS

Wastewater flow in a sewage system is a complex phenomenon which still defies a complete mathematical description.

In Poland, statistical models of stormwater runoff have been developed. One of them has been determined on the basis of many years' research into rainfall and runoff patterns in sewage systems. In this model, the ascending part of the hydrograph was assumed to be described by a linear function, and the descending part has the shape of an exponential curve [7]. The equations of the model make it possible to define the general and peak factors of runoff, the runoff inertia factor, the time from the beginning of a rainfall until the beginning of runoff, and the shape of the hydrograph. It is possible to adapt this model to basins of significantly different sizes and levels of development after verifying the factors which appear in the model equations. These factors allow calculation of the runoff volume, the maximum intensity of runoff flow, rainfall duration, and the period of maximum sewage flow intensity.

The validity of a method for determining a sufficient capacity of reservoirs is based mainly on the analysis of all available inflow hydrographs for a given level of operational reliability of the sewer system. This enables establishing a standard hydrograph by accurate simulation of the sewage storage in a reservoir for a given factor of flow reduction.

Design hydrographs are considered to be those obtained based on at least 25 years of collecting the field data. If a reservoir is designed for an existing sewage system, the actual operating conditions should be taken into account. In some cases, even careful long-term field research can be useless or can insufficiently reflect real operating conditions of an existing sewage system. It is difficult to compare hydrographs obtained for existing sewage systems if the characteristics of a basin are constantly changing.

Theoretically it is possible to distinguish simultaneously one, two or three different intervals of variation in precipitation intensity during the course of a rainfall. This possibility has been analyzed in graphic form by consideration of three standard patterns of change in rainfall intensity [8] expressed by an average precipitation intensity over the entire course of the rainfall.

Such hydrographs can represent stormwater runoff overflow (figure 1a), industrial wastewater, and mixtures of various types of wastewater (figure 1b). The system proposed makes it possible to maintain the shape of a hydrograph similar to the assumed one and permits a considerable simplification of the mathematical description. Thus, each hydrograph can be presented in the form of an ordered set of three kinds of overflow variation:

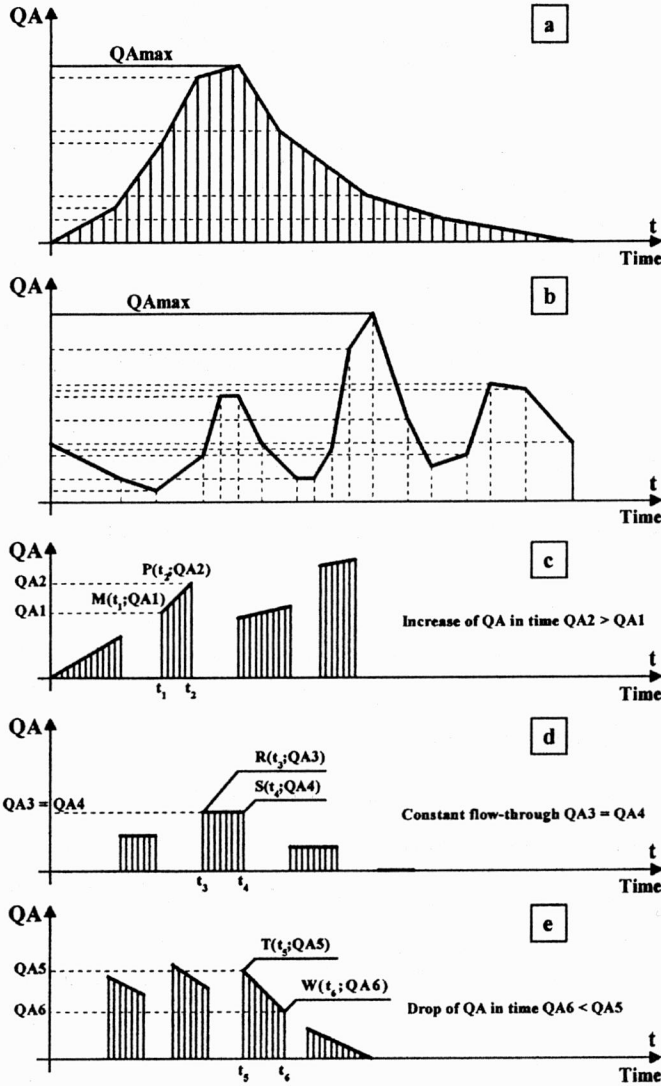

Fig. 1. Scheme of transformation of any inflow hydrograph type into a series of elementary linear functions

- intervals with a linear increase in overflow over time, in which for $t_2 > t_1$ we have $QA_2 > QA_1$ (figure 1c),
- intervals with constant overflow over time, in which for $t \in (t_3, t_4)$ we have $QA_3 = QA_4$ (figure 1d),
- intervals with a linear decrease in overflow over time, in which for $t_6 > t_5$ we have $QA_6 < QA_5$ (figure 1e).

3. MATHEMATICAL MODEL OF TWO-CHAMBER STORAGE RESERVOIR

Using the characteristic sewage inflow hydrographs and taking into account the specific character of the proposed hydraulic systems of multi-chamber reservoirs as well as different filling and evacuation phases, model differential balance equations have been derived in order to describe the flow balance in a non-conventional ZCC reservoir. Theoretical description of sewage accumulation in a ZCC reservoir consists in determining the sewage filling levels in the flow-through and storage chambers in the whole cycle of sewage accumulation, outflow variations in the outflow channel and finally in defining the time of design storm or a quantitative hydrograph and necessary volume of reservoir storage space.

Based on the hydraulic model described in [9], a model balance equation for sewage flow has been formulated for different phases of ZCC reservoir operation, taking into account the sewage levels in the flow-through and storage chambers, which affects the operation and discharge of the internal overflow with the following division of model parameters:

- Input dependent parameters *WZC*:

$$WZC [AA, AP, b, c, c_2, Do, H, Fzr, ha, hc, ho, hp, Kd, Ko, q, QKo, QA (Tp), QK, QAi, QAj, QC, QP, Tdi, Tdj, Tp, \beta, \mu, \mu_1, \mu_2] .$$

- Input independent parameters *WNC*:

$$WNC [Ba, Hu, HrZ, i_a, i_p, l, La, Lp, t_k, t_r, n, n_o, n_r, n_{ro}, \zeta, \chi] .$$

- Output resultant parameters *WWC*:

$$WWC [ACm, h_{\max}, hc_{\max}, QA (TMC), QC_{\max}, Te, To, TMC, VC] .$$

- Dependent variables *ZZC*[*h, H*] and independent variable *ZNC*[*t*].

Sewage accumulation in the flow-through chamber is described by a general equation:

$$dV = AK \cdot dh = QA(t)dt - QO(t)dt . \quad (1)$$

Using model diagrams of inflow variability, we arrived at differential balance equations for a multi-chamber reservoir in the filling range $h_{\max} \geq h \geq 0$ and different sewage inflow variations areas (figure 1c, 1d and 1e) :

$$\frac{dh}{dt} = C1 \cdot t - C2 \cdot h^{0.5} \quad \text{for} \quad QA2 > QA1, \quad (2)$$

$$\frac{dh}{dt} = C6 - C2 \cdot h^{0.5} \quad \text{for} \quad QA2 = QA1, \quad (3)$$

$$\frac{dh}{dt} = C_8 - C_1 \cdot t - C_2 \cdot h^{0.5} \quad \text{for } QA_2 < QA_1. \quad (4)$$

The model equation representing the sewage flow balance during the filling phase of the storage chamber ZCC ($h > h_p, h > H$) can be expressed in the following form (figure 2b):

$$AP \cdot dh = QA(t)dt - QO(t)dt - QC(t)dt. \quad (5)$$

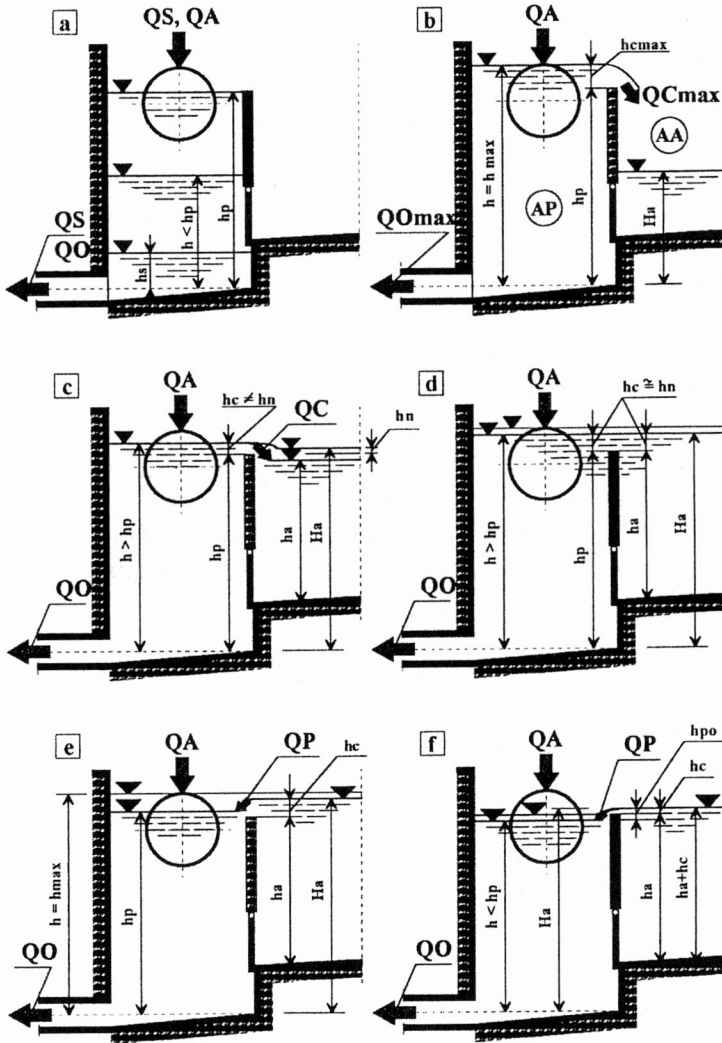

Fig. 2. Models of sewage storage in two-chamber ZCC reservoir at phases of filling and initial phases of emptying

Taking into account the effect of the overflow operation on overflow efficiency, separate groups of differential balance equations have been determined for model areas of sewage inflow variation in order to define sewage flow in the flow-through chamber.

The storage chamber filling under conditions of overflow operation in non-submerged system ($hp > H$, $QA > QO$) is defined by a general equation (figure 2b):

$$AP \cdot dh = QA \cdot dt - QO \cdot dt - QC_n \cdot dt \quad (6)$$

and in a hydraulic system under conditions of overflow flooding by equation (7) for $h > H$ and $H > hp$ (figure 2c):

$$AP \cdot dh = QA \cdot dt - QO \cdot dt - QC_z \cdot dt \quad (7)$$

In a final phase of the ZCC reservoir filling, after the sewage levels have become equal in AP and AA chambers (figure 2d), the increase in sewage volume is described by equation (1) assuming that $AP = AP + AA$. Similarly, after the maximum filling h_{max} in the reservoir has been reached, the sewage level will drop until the difference in sewage levels exceeds Ho .

When a ZCC reservoir is being emptied at $H - h > Ho$, the overflow will first operate in a submerged system at $h \geq hp$ (figure 2e), and the volume difference in AP and AA chambers is defined by a general equation:

$$AP \cdot dh = QA \cdot dt - QO \cdot dt + QP_z \cdot dt \quad (8)$$

When the sewage level continues to drop in the flow chamber at $h < hp$ (figure 2f), the overflow operates in non-submerged system until the sewage level in AA chamber reaches $H = hp$ (figure 3a):

$$AP \cdot dh = QA \cdot dt - QO \cdot dt + QP_n \cdot dt \quad (9)$$

During ZCC reservoir evacuation the difference in sewage levels ho in the AA and AP chambers has to arise which allows the flap valve to open. The difference in the filling heights can be achieved in a reservoir in three different phases of its evacuation and this is affected by many factors.

Such a situation requires separate model equations. When the difference in sewage levels ho appears in these chambers during the overflow operation in a submerged system (figure 3b), the following equation should be used:

$$AP \cdot dh = QA \cdot dt - QO \cdot dt + QP_z \cdot dt + QK \cdot dt \quad (10)$$

During overflow operation in non-submerged system (figure 3c) equation (10) has the following form:

$$AP \cdot dh = QA \cdot dt - QO \cdot dt + QP_n \cdot dt + QK \cdot dt \quad (11)$$

In a hydraulic system, the last step enabling the flap valve to open is lowering of the sewage level in the storage chamber and in the flow chamber (figure 3d) to $H = hp$ and $h = hp - ho$, respectively. This situation is expressed by the equation:

$$AP \cdot dh = QA \cdot dt - QO \cdot dt + QK \cdot dt \quad (12)$$

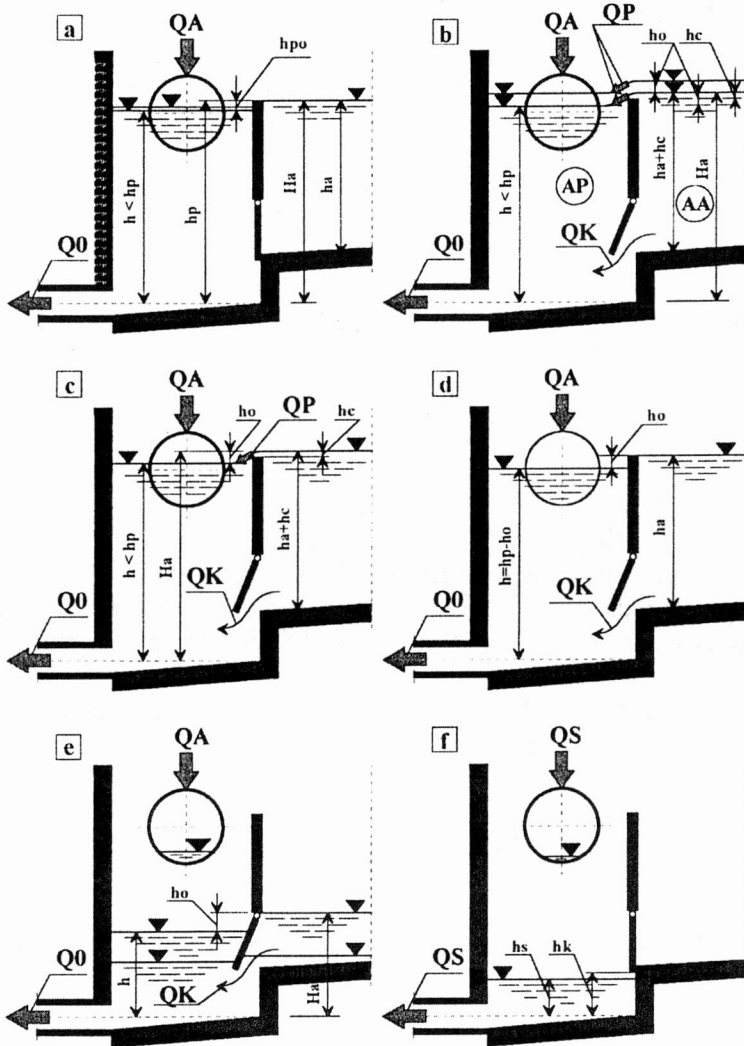

Fig. 3. Models of sewage storage in two-chamber ZCC reservoir at emptying phases

When there is no sewage inflow to the ZCC reservoir, while AA and AP chambers are partly filled (figure 3e), the balance equation in the flow chamber is:

$$AP \cdot dh = QK \cdot dt - QO \cdot dt. \quad (13)$$

The final phase is the evacuation of the flow chamber only when the storage chamber is empty and the inflow is QS or stops (figure 3f):

$$AP \cdot dh = - QO \cdot dt. \quad (14)$$

The last terms of equations (6), (7), (8) and (9) define the overflow discharge observed in different hydraulic systems, while the final term in equation (10) defines the discharge through the hole with flap valve. Formulae for calculating the overflow discharge and hole in the stationary partition are as follows:

$$QC_n = 0.943 \cdot g^{0.5} \cdot b \cdot \mu_1(h - hp)^{1.5}, \quad (15)$$

$$QC_z = 0.943 \cdot g^{0.5} \cdot b \cdot \mu_2(h - H)^{1.5} + 1.41 \cdot g^{0.5} \cdot b \cdot \mu_3(H - hp)(h - H)^{0.5}, \quad (16)$$

$$QP_n = 2.95 \cdot b \cdot \mu_1(H - hp)^{1.5}, \quad (17)$$

$$QP_z = 2.95 \cdot b \cdot \mu_2(H - h)^{1.5} + 4.43 \cdot b \cdot \mu_3(h - hp)(H - h)^{0.5}, \quad (18)$$

$$QK = 1.41 \cdot g^{0.5} \cdot \mu_k \cdot F_z(H - h)^{0.5}. \quad (19)$$

The model equations describe sewage accumulation in a flow chamber of the ZCC reservoir. For a detailed description of sewage accumulation in such a reservoir [10] a set of balance equations describing simultaneously the sewage volume and filling variation in both chambers are required. Using the model equations for the characteristic filling and evacuation phases in a ZCC reservoir and introducing notations for constants in formulae (15), (16), (17), (18) and (19) a separate differential balance equation in ZCC reservoir has been desired.

Filling phases in the chambers of a ZCC reservoir are the following:

1. The overflow operates in non-submerged system

a) when inflow is $QA2 > QA1$

$$\frac{dh}{dt} = C1 \cdot t - C2 \cdot h^{0.5} - C3(h - hp)^{1.5}, \quad (20)$$

b) when inflow is $QA2 = QA1$

$$\frac{dh}{dt} = C6 - C2 \cdot h^{0.5} - C3(h - hp)^{1.5}, \quad (21)$$

c) when inflow is $QA2 < QA1$

$$\frac{dh}{dt} = C8 - C1 \cdot t - C2 \cdot h^{0.5} - C3(h - hp)^{1.5}. \quad (22)$$

2. The overflow operates in submerged system

a) when inflow is $QA2 > QA1$

$$\frac{dh}{dt} = C1 \cdot t - C2 \cdot h^{0.5} - C4(h - H)^{1.5} - C5(H - hp)(h - H)^{0.5}, \quad (23)$$

b) when inflow is $QA2 = QA1$

$$\frac{dh}{dt} = C6 - C2 \cdot h^{0.5} - C4(h - H)^{1.5} - C5(H - hp)(h - H)^{0.5}, \quad (24)$$

c) when inflow is $QA2 < QA1$

$$\frac{dh}{dt} = C8 - C1 \cdot t - C2 \cdot h^{0.5} - C4(h - H)^{1.5} - C5(H - hp)(h - H)^{0.5}. \quad (25)$$

The constants $C3$, $C4$ and $C5$ can be calculated from equations (36), (37) and (38).

Complete accumulation phase in ZCC reservoir. When the sewage levels in the flow and storage chambers are different, i.e. $h - H \leq Ho$, the effect of overflow operation is neglected and a ZCC reservoir operates as a traditional reservoir of the surface $AP = AK = AP + AA$ until the maximum filling height $h = h_{max}$ is achieved. For the description of this filling phase model equation (1) and relation (4) should be used because of the nature of sewage inflow to the reservoir. The balance between the outflow and the maximum outflow $QA = QO_{max}$ means complete accumulation and makes it possible to define all design parameters if this accumulation was determined for a reliable hydrograph of sewage inflow.

Evacuation phases of ZCC reservoir chambers at the inflow $QA2 < QA1$. As in the phase of complete accumulation, the evacuation of a ZCC reservoir is represented by balance equation (4) for a traditional reservoir until the level difference $H - h \geq Ho$ is reached, which requires overflow operation.

1. Overflow operation in submerged system:

$$\frac{dh}{dt} = C8 - C1 \cdot t - C2 \cdot h^{0.5} + C4(H - h)^{1.5} + C5(h - hp)(H - h)^{0.5}. \quad (26)$$

2. Overflow operation in non-submerged system:

$$\frac{dh}{dt} = C8 - C1 \cdot t - C2 \cdot h^{0.5} + C3(H - hp)^{1.5}. \quad (27)$$

3. Overflow does not operate $H = hp$ at $H - h < ho$ (equation (4)).

4. The flap valve opens and operates:

a) in submerged system:

$$\frac{dh}{dt} = C8 - C1 \cdot t - C2 \cdot h^{0.5} + C4(H - h)^{1.5} + C5(h - hp)(H - h)^{0.5} + C9(H - h)^{0.5}, \quad (28)$$

b) in non-submerged system:

$$\frac{dh}{dt} = C8 - C1 \cdot t - C2 \cdot h^{0.5} + C3(H - hp)^{1.5} + C9(H - h)^{0.5}, \quad (29)$$

c) at constant sewage level in an AA chamber:

$$\frac{dh}{dt} = C9 - C1 \cdot t - C2 \cdot h^{0.5} + C9(H - h)^{0.5}, \quad (30)$$

d) no inflow to reservoir:

$$\frac{dh}{dt} = -C2 \cdot h^{0.5} + C9(H - h)^{0.5}, \quad (31)$$

e) emptying of an AP chamber in a combined sewage system (KO) and inflow (QS):

$$\frac{dh}{dt} = C6 - C2 \cdot h^{0.5}, \quad (32)$$

f) no inflow and an AP chamber is being emptied:

$$\frac{dh}{dt} = -C2 \cdot h^{0.5}. \quad (33)$$

The constants in general balance equations are given by the following equations:

$$C1 = QA \cdot AP^{-1} \cdot Tp^{-1}, \quad (34)$$

$$C2 = 1.41 \cdot g^{0.5} \cdot \mu \cdot Fo \cdot AP^{-1}, \quad (35)$$

$$C3 = 0.943 \cdot g^{0.5} \cdot \mu_1 \cdot b \cdot AP^{-1}, \quad (36)$$

$$C4 = 0.943 \cdot g^{0.5} \cdot \mu_2 \cdot b \cdot AP^{-1}, \quad (37)$$

$$C5 = 1.41 \cdot g^{0.5} \cdot \mu_3 \cdot b \cdot AP^{-1}, \quad (38)$$

$$C6 = QA \cdot AP^{-1}, \quad (39)$$

$$C7 = QA \cdot Td \cdot Tp^{-1} \cdot AP^{-1}, \quad (40)$$

$$C8 = C6 + C7 = QA \cdot AP^{-1} (1 + Td \cdot Tp^{-1}), \quad (41)$$

$$C9 = 1.41 \cdot g^{0.5} \cdot \mu_k \cdot Fz \cdot AP^{-1}. \quad (42)$$

4. CONCLUSIONS

This is a study devoted to a prospective importance of a new generation of multi-chamber reservoirs of high storage capacity to an efficient management of sewage runoff.

Scientific principles have been developed for designing such reservoirs in various sewage systems for an arbitrary function describing fluctuations in sewage inflow. Both general and partial mathematical models are proposed for hydraulic models of the ZCC two-chamber reservoirs to characterize its filling and emptying phases, taking into account variation in the flow rate and operation of different control systems that regulate sewage flow in reservoirs.

REFERENCES

- [1] DZIOPAK J., *Model matematyczny zbiornika retencyjnego kanalizacji deszczowej*, Politechnika Krakowska, Monografia nr 31, Kraków, 1984.
- [2] DZIOPAK J., *Równanie bilansu akumulacji ścieków deszczowych w zbiorniku retencyjnym*, GWiTS, nr 10, Warszawa, 1987.
- [3] DZIOPAK J., *Model matematyczny zbiornika odciążającego hydraulicznie kanalizację deszczową*, GWiTS, nr 6, Warszawa, 1988.
- [4] DZIOPAK J., JASIK H., *Możliwości symulacji retencjonowania ścieków deszczowych w kanalizacyjnym zbiorniku retencyjnym*, GWiTS, nr 8, Warszawa, 1988.
- [5] BŁASZCZYK P., *Ulepszone metody wymiarowania kanalizacji deszczowej i ogólnospławnej*, praca zbiorowa, Postęp techniczny w kanalizacji, PZITS, Wrocław, 1977.
- [6] BŁASZCZYK P., *Metody obliczania natężeń przepływów ścieków opadowych miarodajnych do wymiarowania kanałów*, Ochrona Środowiska, 1988, nr 3–4 (36–37), Wrocław.
- [7] FIDAŁA-SZOPE M., PAWLUŚKIEWICZ M., *Wyznaczanie hydrogramu ścieków opadowych odprowadzanych kanalizacją deszczową ze zlewni miejskiej*, Program HYD, Praca IOŚ, Warszawa, 1986.
- [8] DZIOPAK J., *Analiza teoretyczna i modelowanie wielokomorowych zbiorników kanalizacyjnych*, Monografia nr 125, Politechnika Krakowska, Kraków, 1992.
- [9] DZIOPAK J., *Proposed physical models for gravitational dual-chamber storage reservoir type Contract*, EPE, 2002, Vol. 28, No. 3.
- [10] DZIOPAK J., *Oszczędnościowy zbiornik retencyjny typu CONTRACT*, GWiTS, nr 1, Warszawa, 1990.

MODELE MATEMATYCZNE DZIAŁANIA GRAWITACYJNEGO ZBIORNIKA RETENCYJNEGO DWUKOMOROWEGO TYPU CONTRACT

Różne fazy procesu akumulacji ścieków, opisane na podstawie modeli hydraulicznych, odzwierciedlają rzeczywiste sposoby praktycznego wykorzystania możliwości retencyjnych wszystkich elementów zbiorników retencyjnych nowej generacji, których przykładem jest dwukomorowy zbiornik typu CONTRACT. Charakterystyczne hydrogramy dopływu ścieków deszczowych umożliwiły wyznaczenie modelowych równań różniczkowych bilansu dla innowacyjnego zbiornika. Teoretyczny opis akumulacji ścieków w dwukomorowym zbiorniku sprowadza się do określenia poziomów napelnienia ściekami komory przepływowej i komory retencyjnej w całym cyklu akumulowania ścieków, przy czym uwzględnia się zmienność odpływu w kanale odpływowym i geometrię zbiornika retencyjnego. Równania odzwierciedlają odmienne funkcjonowanie przelewu wewnętrznego, oddzielającego komory zbiornika, który w wielu fazach opróżniania zbiornika działa jako zatopiony lub niezatopiony oraz razem z otwartym zaworem kłapowym. Wszystkie charakterystyczne fazy działania zbiornika przedstawiono w formie graficznej.

