

Stability of the phase reconstruction from the intensity distribution at the input and output of an optical differentiating operator*

PIOTR KIEDROŃ

Institute of Physics, Technical University of Wrocław, Wybrzeże Wyspiańskiego 27, 50-370 Wrocław, Poland.

In the paper the stability problem in phase reconstruction by the method of intensity measurement both in output and input of the differentiation operator are examined. Such operator may be optically realized by locating a linear amplitude filter at the exit pupil of a coherent optical system. The reconstruction process simulation was carried out by using the Gerchberg-Saxton algorithm.

1. Introduction

It is well known that there exists no method of direct phase measurement of the complex amplitude describing the coherent optical field. This shortcoming became a reason for development of indirect measuring techniques such as interferometry or holography. All these methods are based on the possibility of visualizing the phase in the form of interference fringes. However, in the practical usage of the methods an important property of the optical signal, i.e., its analyticity is, usually, not exploited. It turns out that the analyticity, and more precisely, the band-limitedness of the complex amplitude $f(x)$ is an information which essentially reduces the selection of the admissible set of phases $\varphi(x)$ such that the complex amplitude $|f(x)|\exp[i\varphi(x)]$ be band-limited, too [1-3]. So far, the form of the additional a priori information which would assure the uniqueness of the reconstruction from one distribution of intensity is unknown, especially, if it should be simultaneously physically realizable or verifiable. In the papers [4, 5] such an a priori information was sought, however, the conditions formulated in these works not always assure the uniqueness. The practical usefulness of the methods suggested in these papers may raise some doubts, even, if the disadvantageous cases of nonuniqueness are assumed to be little probable. Because the method of unique phase reconstruction from one measurement, even if it ever exists, seems to be off small stability.

In the case when several "independent" measurements are made the formulation of the conditions of uniqueness and stability as well as elaboration of the suitable algorithm are much easier. For instance, if the intensity in the image plane of the optical system is measured before and after defocusing, the uniqueness [4, 6] and stability [7] are assured. Also, the simple algorithms for phase determination in this case have been already given [8, 9].

* This work was carried on under the Research Project. M.R. I.5.

Another known method of phase determination consists in the measurement of intensity in both the exist pupil and the image plane [10, 11]. Although the examination of uniqueness is still troublesome [12–15] usually it should not be considered to be a waist of time, since in the case of positive answer a very effective algorithm of Gerchberg-Saxton (GS-algorithm) may be employed which, in addition, offers high stability of the procedure [11, 17, 18].

The subject of this paper is the applicability of the GS-algorithm to the method of phase reconstruction from the intensity distribution at the input and output of an optical differentiating operator as formulated in papers [19–21]. For the sake of convenience, we recall here the basic ideas of the method. In this method the intensity $i_1(x)$ generated by the complex amplitude

$$f_1(x) = \int_{-\omega_0}^{\omega_0} F(\omega) e^{2\pi i x \omega} dx \omega \quad (1)$$

and the intensity $i_2(x)$ generated by the complex amplitude

$$f_2(x) = \alpha \frac{df_1(x)}{dx} + \beta f_1(x), \quad (2)$$

are measured, where ω_0 is the cut-off frequency and

$$\alpha = -iA/2\pi\omega_0, \quad \beta = B. \quad (3)$$

The complex amplitude $f_2(x)$ may be realized optically after inserting into the frequency plane Ω a transparency of transmittance

$$T(\omega) = A \frac{\omega}{\omega_0} + B \quad (4)$$

where A, B are the real constants, which must fulfil the uniqueness condition [20]

$$|B \setminus A| \geq 1 \quad (5)$$

so that the intensities

$$i_k(x) = |f_k(x)|^2, \quad k = 1, 2 \quad (6)$$

determine uniquely (with the accuracy of an additive constant) the phase of the complex amplitudes $f_k(x)$ [19–21].

In the two-dimensional case the transparence $T(\omega)$ should be rotated by an angle $\pi/2$ and an additional third measurement of intensity $i_3(x)$ in the image plane X must be carried out [21]. Due to the character of eqs. (2) and (3) the method of the phase recovery described above will be called a differential filtration method (DFM).

In the paper [20] the DFM has been tested by using the finite sums algorithm developed in [8]. The further examinations showed an extreme instability of this algorithm caused by the cumulation of the rounding errors. This disadvantage has been noticed also in papers [22], where this algorithm was applied to the method described in paper [6].

These facts speak in favour of the hypothesis that the instability is due rather to the algorithm than to the DFM itself. Therefore, the examination of stability of the DFM as well as the verification of the applicability of the GS-algorithm in its version in paper [9] is the aim of this work.

The proof of stability of the DFM as well as the testing of the GS-algorithm have been carried out for the one-dimensional case. The possibility of generalization of this consideration on the two-dimensional case is discussed at the end of this paper.

2. Stability

Below, it will be shown that the error of phase reconstruction is a continuous function of the measurement errors, which tends to zero together with decreasing measurement errors.

Let $A_1(x)$, $\varphi_1(x)$ denote the real amplitude and phase of the complex amplitude $f_1(x)$. After substituting this complex amplitude $f_1(x)$ to the formula (2) and using the definition of intensity (6) the following equation for the phase derivative is obtained

$$[\varphi_1'(x)]^2 + \gamma\varphi_1'(x) + \left| \frac{\beta}{\alpha} \right|^2 + \frac{1}{4} \left| \frac{i_1'(x)}{i_1(x)} \right|^2 - \frac{1}{|\alpha|^2} \frac{i_2(x)}{i_1(x)} = 0. \quad (7)$$

To derive this equation the following identities and notations were used:

$$A_1'(x) = \frac{1}{2} \frac{i_1'(x)}{\sqrt{i_1(x)}}, \quad (8)$$

$$\operatorname{Re}(\alpha^* \beta) = 0, \quad \frac{2\operatorname{Im}(\alpha^* \beta)}{|\alpha|^2} = \gamma. \quad (9)$$

The equation (8) is valid for such x for which $A_1(x) \neq 0$. For the remaining x the problem of stability does not appear at all, since the phase $\varphi_1(x)$ is indefinite whenever $A_1(x) = 0$.

Suppose that instead of the intensities $i_1(x)$, $i_2(x)$ the intensities $i_1(x) + \Delta i_1(x)$, $i_2(x) + \Delta i_2(x)$ are given, where $\Delta i_1(x)$ and $\Delta i_2(x)$ are responsible for the errors of measurement and reconstruction of intensity from the discrete measurement representation. Then instead of the phase $\varphi_1(x)$ we may obtain the phase $\varphi_1(x) + \Delta\varphi_1(x)$, which is connected with the measured quantities in the following way

$$[\varphi_1'(x) + \Delta\varphi_1'(x)]^2 + \gamma[\varphi_1'(x) + \Delta\varphi_1'(x)] + \left| \frac{\beta}{\alpha} \right|^2 + \frac{1}{4} \left| \frac{i_1'(x) + \Delta i_1'(x)}{i_1(x) + \Delta i_1(x)} \right|^2 - \frac{1}{|\alpha|^2} \frac{i_2(x) + \Delta i_2(x)}{i_2(x) + \Delta i_2(x)} = 0. \quad (10)$$

As it is seen from equation (10), it is assumed that the reconstruction error of the intensity derivative is equal to $\Delta i_1'(x)$, which means that in the course of numerical differentiation no error is committed. By subtracting (7) from (10) the equation for the reconstruction error of the phase derivative is obtained.

$$[(\Delta\varphi_1'(x)]^2 + a(x)\Delta\varphi_1'(x) + [\varepsilon_1'(x) - \varepsilon_1(x)]b(x) + [\varepsilon_1(x) - \varepsilon_2(x)]c(x) = 0, \quad (11)$$

where

$$\varepsilon_1(x) = \frac{\Delta i_1(x)}{i_1(x)}, \quad \varepsilon_2(x) = \frac{\Delta i_2(x)}{i_2(x)}, \quad \varepsilon'_1(x) = \frac{\Delta i'_1(x)}{i'_1(x)}, \quad a(x) = 2\varphi'(x) + \gamma,$$

$$b(x) = \frac{1}{4} \frac{i'_1(x)}{i_1(x)} \frac{2 + \varepsilon_1(x) + \varepsilon_2(x)}{[1 + \varepsilon_1(x)]^2}, \quad c(x) = \frac{i_2(x)}{i_1(x)} \frac{1}{1 + \varepsilon_1(x)}.$$

The solution of the equation (11) is received in the form

$$\Delta\varphi'_1(x) = \frac{1}{2} \left\{ -a(x) + s(x) [a^2(x) - 4(\varepsilon'_1(x) - \varepsilon_1(x))b(x) - 4(\varepsilon_1(x) - \varepsilon_2(x))c(x)]^{1/2} \right\}, \quad (13)$$

where

$$s(x) = \begin{cases} 1 & a(x) > 0 \\ 1 \text{ or } -1 & a(x) = 0 \\ -1 & a(x) < 0. \end{cases}$$

Such a choice of the function $s(x)$ assures, in accordance with the results obtained in [20], the unique solution $\Delta\varphi'_1(x) \equiv 0$ in the case when $\varepsilon_1(x) \equiv \varepsilon_2(x) \equiv 0$. If $\Delta i_1(x)$ is an arbitrary function, then the condition $\varepsilon_1(x) \rightarrow 0$ does not imply the condition $\varepsilon'_1(x) \rightarrow 0$. In accordance with the equation (1), $f_1(x)$ and hence $i_1(x)$ are the band-limited functions. Therefore the reconstruction of intensity $i_1(x)$ from the discrete measurement representation should be carried out in such a way that $i_1(x) + \Delta i_1(x)$ be the band-limited function. For this purpose it is sufficient to give the reconstructed intensity in the form of a finite Shannon series. Then

$$\Delta i_1(x) = \int_{-2\omega_0}^{2\omega_0} \Delta I(\omega) e^{2\pi i x \omega} d\omega, \quad (14)$$

$$\Delta i'_1(x) = \int_{-2\omega_0}^{2\omega_0} 2\pi i \omega \Delta I(\omega) e^{2\pi i x \omega} d\omega. \quad (15)$$

By applying the Schwartz inequality to the last equation and taking advantage of Parseval theorem the following estimation of the derivative of the intensity reconstruction error is obtained

$$|\Delta i'_1(x)| \leq 2\pi \sqrt{\frac{16}{3}} \omega_0^{3/2} \left[\int_{-\infty}^{\infty} |\Delta i_1(x)|^2 dx \right]^{1/2}. \quad (16)$$

The right hand side of inequality (16) is proportional to the truncation error of the Shannon series. It may be assumed that $|\Delta i'_1(x)|$ may be made arbitrarily small by performing the sufficiently accurate reconstruction of intensity $i_1(x)$.

In order to show the stability two cases are discussed: $a(x) = 0$ and $a(x) \neq 0$. In the second case the square root in the formula (13) is developed into Taylor series taking only

first two terms to the further considerations. In this way the following estimation of the reconstruction error for both the cases may be made

$$|\Delta\varphi'_1(x)| = [(\varepsilon_1(x) - \varepsilon'_1(x))b(x) + (\varepsilon_2(x) - \varepsilon_1(x))c(x)]^{1/2} \quad (17a)$$

$$|\Delta\varphi'_1(x)| \leq |\varepsilon_1(x) - \varepsilon_1(x)| \left| \frac{b(x)}{a(x)} \right| + |\varepsilon_2(x) - \varepsilon_1(x)| \left| \frac{c(x)}{a(x)} \right| + \left| o \left(\left[(\varepsilon_1(x) - \varepsilon'_1(x)) \frac{b(x)}{a(x)} + (\varepsilon_2(x) - \varepsilon_1(x)) \frac{c(x)}{a(x)} \right]^2 \right) \right|. \quad (17b)$$

Finally, it may be stated that for each $\delta > 0$ there exist positive numbers ε , ε_1 , ε_2 such that the inequalities*

$$|\Delta i_1(x)| < \varepsilon_1, \quad |\Delta i_2(x)| < \varepsilon_2, \quad (18a)$$

$$\|\Delta i_1(x)\| < \varepsilon \quad (18b)$$

imply the following inequality

$$|\Delta\varphi'_1(x)| < \delta. \quad (19)$$

By the same means, the phase reconstruction stability is proved since from the inequality (19) it is easy to show that also $|\Delta\varphi_1(x)|$ will be arbitrarily small.

The stability of reconstruction depends upon the algorithm applied. Practically, from eq. (7) the phase cannot be determined. For each x this equation yields, in general, two algebraic roots. Unfortunately, there exists no criterion which would enable to reject one of these roots. First, all the solutions should be known to choose that one which determines the phase of the band-limited function of cut-off frequency not exceeding ω_0 . Therefore, such algorithm should be rather applied which, at its each step remembers that the input signal is a band-limited function of cut-off frequency not greater than ω_0 . This property is characteristic of methods based on integral equations. There, instead of looking directly the phase $\varphi(x)$, the spatial spectrum $F(\omega)$ is determined from the system of integral equations (22).

The intensities obtained from the first ($k = 1$) and second ($k = 2$) measurements are, in accordance with (1), (2) and (4) of the form

$$i_k(x) + \Delta i_k(x) = \left| \int_{-\omega_0}^{\omega_0} G(\omega) T_k(\omega) e^{2\pi i x \omega} d\omega \right|^2, \quad (20)$$

where

$$T_1(\omega) = 1, \quad (21a)$$

$$T_2(\omega) = A \frac{\omega}{\omega_0} + B, \quad (21b)$$

* The inequality (18b) means that the rms $\|\Delta i_1(x)\|$ is sufficiently small.

under assumption that

$$i_k(x) = \left| \int_{-\omega_0}^{\omega_0} F(\omega) T_k(\omega) e^{2\pi i x \omega} d\omega \right|^2. \quad (22)$$

By applying the formulae (20) and (22) the discussion, identical with that presented in paper [7], may be carried to prove the stability of the solution of two nonlinear integral equations (22). The formulation of the reconstruction problems as a problem of solving eq. (22) offers two basic advantages. Firstly, the eq. (22) preserves the a priori information about the signal $f_1(x)$, i.e., about its band-limitedness and the value of the cut-off frequency. Secondly, the functions $T_1(\omega)$, $T_2(\omega)$ may differ in form from (21a) and (21b) which does not change the nature of the problem to be solved, provided that the differences introduce no nonuniqueness to the sought solution.

3. GS-Algorithm

As already mentioned in the *Introduction*, in order to determine the phase from the intensity distribution in both the image plane and the exit pupil the papers [10, 11] propose an algorithm based on fast Fourier transform (FFT). This algorithm has been modified to reconstruct the phase from the intensities obtained from the measurement in the image plane of the optical system before and after defocussing the system [9]. In this version the GS-algorithm may be applied to the method of phase reconstruction suggested in this paper. For the sake of convenience, the ideas of the algorithm have been presented in the block diagram (fig. 1). It will be briefly discussed below.

At first, the complex amplitude $f_1^1 = \sqrt{i_1} \exp(i\varphi)$, where φ is an arbitrary phase distribution, for instance, that obtained from a generator of random numbers, and f_1^1 is the first approximation of the complex amplitude $f_1(x)$. Next, the complex amplitude \bar{f}_2^1 is determined which is the first approximation of the signal $f_2(x)$. This is obtained by applying direct and reverse Fourier transform operation, successively*

$$\bar{f}_2^1 = \mathcal{F}^{-1} \left\{ \mathcal{F} \{ f_1^1 \} \frac{T_2}{T_1} \right\}. \quad (23)$$

Next, the information obtained in the second measurement, i.e., that concerning the amplitude of the function \bar{f}_2^1 is replaced by the accurate amplitude $\sqrt{i_2}$ by making substitution

$$f_2^1 \leftarrow \frac{\bar{f}_2^1}{|\bar{f}_2^1|} \sqrt{i_2}. \quad (24)$$

Further, from the formula

$$\bar{f}_1^2 = \mathcal{F}^{-1} \left\{ \mathcal{F} \{ f_2^1 \} \frac{T_1}{T_2} \right\}, \quad (25)$$

* The functions being in braces in the formulae (23) and (25) are subject to the condition of being zero outside the interval $[-\omega_0, \omega_0]$. Thus, the information a priori about the value of cut-off frequency is exploited.

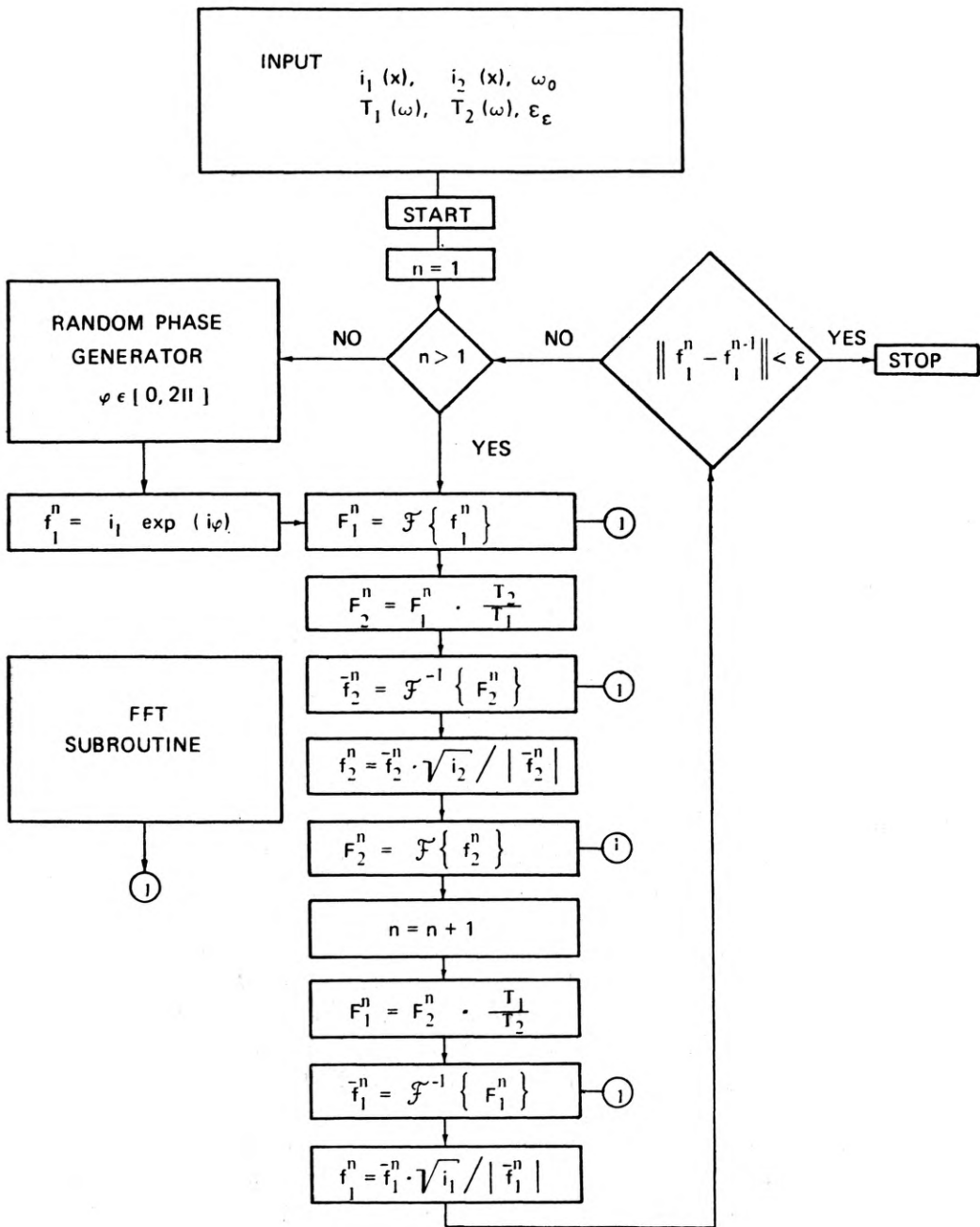

Fig. 1

the second approximation of the complex amplitude $f_1(x)$ is obtained. Next, the measurement information obtained in the first measurement is exploited by making substitution

$$f_1^2 \leftarrow \frac{\bar{f}_1^2}{|\bar{f}_1^2|} \sqrt{i_1}. \quad (26)$$

This cycle is repeated, i.e., the functions f_2^3, f_1^3 and so on are determined consecutively from the formulae (23)–(26) by replacing each time the calculated amplitude $|\bar{f}_k^n|$ by amplitude known from the measurement $\sqrt{i_k}$. Due to the assured uniqueness of the reconstruction the rms error

$$\|f_k^n - f_k\| = \left[\sum_{i=1}^M |f_k^n(x_i) - f_k(x_i)|^2 \right]^{1/2}, \quad (27)$$

where $\{x_1, \dots, x_M\}$ is a set of points*, at which the intensities $i_1(x), i_2(x)$ are known, should tend to zero when n increases to infinity.

4. Simulation of the reconstruction process

The algorithms were tested for the following complex amplitude distributions in the exit pupil plane

$$\begin{aligned} F_I(\omega) &= 1, \\ F_{II}(\omega) &= \sin \omega^3 + i \cos [\omega \sin \omega], \\ F_{III}(\omega) &= \exp i \omega^2, \\ F_{IV}(\omega) &= 1 + 2 \sin 2\pi \omega. \end{aligned} \quad (28)$$

It has been assumed that the cut-off frequency ω_0 is equal to 1. The parameters of the filter $T_2(u)$ were accepted as follows: $A = 0.015, B = 0.8$. Such a choice assures the fulfillment of the uniqueness condition ($|B/A| \geq 1$) and the condition of transmittance normalization ($|T_2(u)| \leq 1$).

The complex amplitudes (28) are given in $M = 128$ points. In 65 points the functions are given inside the interval $[-\omega_0, \omega_0]$, while in 63 points the value $F_1(\omega) = \dots = F_{IV}(\omega) = 0$ was set outside this interval. Next, by applying the FFT algorithm the functions $f_1(x), f_2(x)$ has been calculated**. In order to obtain the first approximation no random number generator was used, but the phase of the function for which FFT is equal to 1 in 128 points was assumed as the initial function.

The errors of reconstruction were computed for the complex amplitudes $F(u)$. In order to become independent of the unknown factor $\exp(ic)$ such real constant c was sought which would minimize rms of $\|F - \exp(ic)F^n\|$, where $F^n(\omega)$ is the complex amplitude in the exit pupil obtained as a results of the n -th iteration of the algorithm. The following errors of reconstruction were calculated:

* It is requested that these points x_i fulfilled the Nyquist condition, i.e., the inequality $|x_{i+1} - x_i| < 1/4\omega_0$.

** The subroutine FFT given in [23] was used. All the calculations were made on Odra 1305 computer.

— Error of amplitude reconstruction

$$e_A(n) = \frac{\| |F| - |F^n| \|}{\|F\|} 100\%, \quad (29)$$

— Error of phase reconstruction

$$e_p(n) = \frac{\|\varphi - (\varphi^n + c)\|}{\|\varphi\|} 100\%, \quad (30)$$

where $\varphi(\omega)$, $\varphi^n(\omega)$ are the phases of complex amplitudes $F(\omega)$, $F^n(\omega)$.

— Error of phase reconstruction in the point ω_j

$$e_p(n, j) = \frac{|\varphi(\omega_j) - (\varphi^n(\omega_j) + c)|}{|\varphi(\omega_j)|} 100\%. \quad (31)$$

— Error of reconstruction of imaginary part in the point ω_j

$$e_I(n, j) = \frac{|Im F(\omega_j) - Im(F^n(\omega_j)e^{ic})|}{|Im F(\omega_j)|} 100\%. \quad (32)$$

The error reconstruction of real part $e_R(n, j)$ may be analogically calculated.

The formulae discussed above are useful only for testing the algorithm. They may not be applied in practice when the amplitude $F(\omega)$ is unknown. Therefore, a criterion determining the quality of solution must be additionally given. Similarly, as it was the case considered in the works [10, 11], the algorithm was stopped when the error

$$\Delta(n) = \|f_1^n - f_1^{n-1}\| \quad (33)$$

remained practically constant with further increase of n . In some cases it has been stated that the condition $\Delta(n) \approx 0$ does not indicate the good approximation. Therefore, there appears an additional problem of rejecting a wrong solution. The reconstruction error defined below may rationalize the decision-making procedure concerning the acceptance or rejection of the solution

$$\varepsilon(n) = \frac{\|\bar{f}_1^n - \sqrt{i_1}\|}{\|\sqrt{i_1}\|} 100\%. \quad (34)$$

It has been noticed that $\varepsilon(n)$ decreases with the errors defined by the formulae (29)–(32) and remains great whenever those errors are great. In fig. 2 the run of dependence $\varepsilon(n)$ obtained for the intensity reconstruction $F_I(\omega)$ has been shown. The proportionality of the errors $e_A(n)$ and $e_p(n)$ to $\varepsilon(n)$ has been stated. Similar proportionality have been observed for the functions $F_{III}(\omega)$ and $F_{IV}(\omega)$, the reconstruction of which may be considered to be unsuccessful in accordance with the table of results. The error $\varepsilon(n)$ was greater by one order of magnitude than that in the cases when the reconstruction was correct (tab.). Hence, it may be concluded that the magnitude of error $\varepsilon(n)$ may be used as a criterion of correctness when no additional information about the reconstructed phase is available.

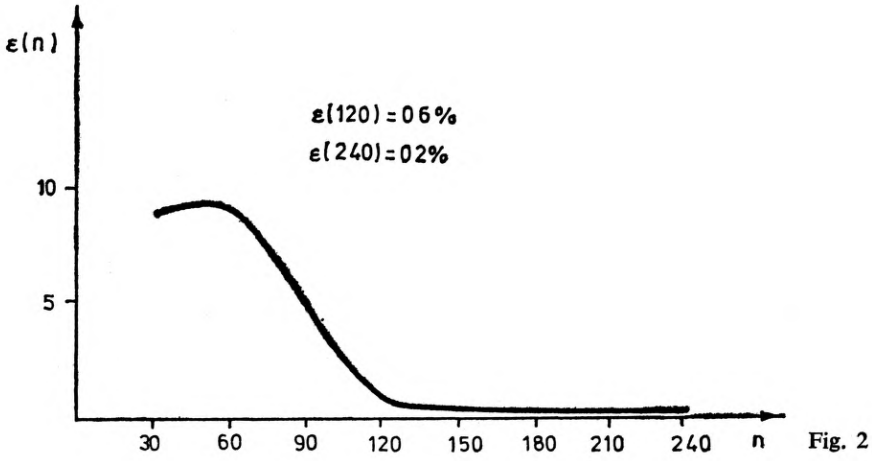

Fig. 2

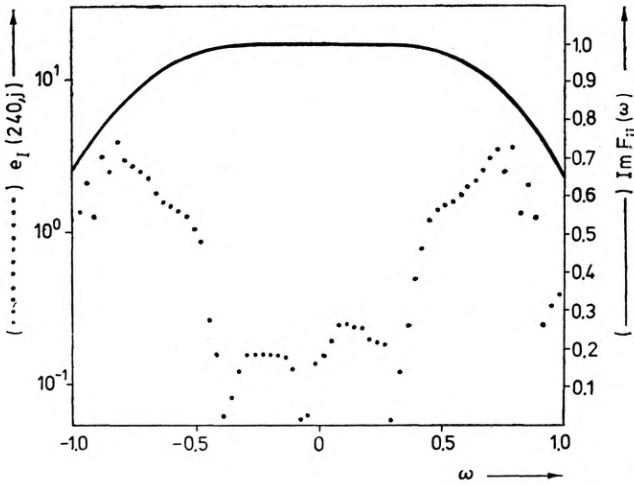

Fig. 3

Table

	n	$\epsilon(n)$	t [min]	$e_p(n)$	$e_A(n)$
F_I	240	0.2	22	0.1	1.7
F_{II}	240	0.16	22	0.7	2.1
F_{III}	60	2.78	5.5	71.9	32.4
	360	2.77	33	72.1	32.3
F_{IV}	60	1.04	5.5	196.5	59.1
	360	1.01	33	164.8	58.0

In figures 3 and 4 the relations $e_1(j, n)$, $e_p(j, n)$ are presented for the function $F_{II}(\omega)$. As already mentioned small reconstruction errors were obtained also for the function $F_I(\omega)$. Unfortunately, the reconstruction of the complex amplitudes F_{III} and F_{IV} was unsuccessful. This is especially well visible in fig. 5, where the shown reconstructed imaginary part $I_m[F_{III}^{60}(\omega)e^{j\tau}]$ may not be accepted as a solution.

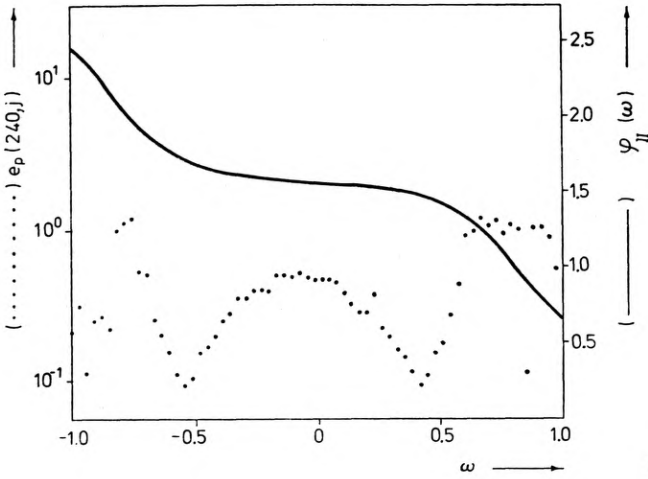

Fig. 4

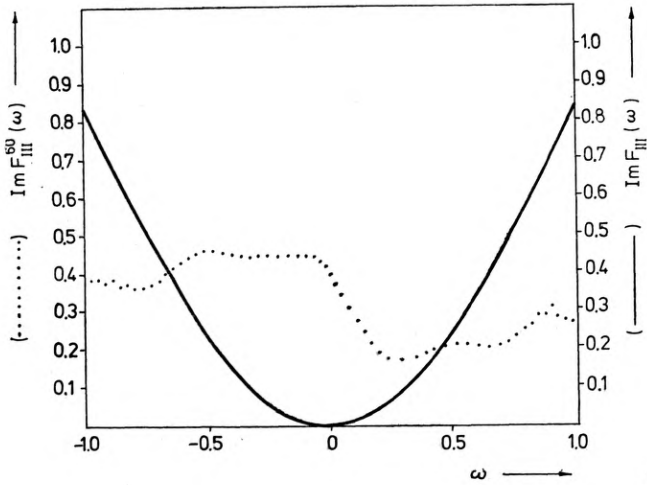

Fig. 5

5. Concluding remarks

The applicability of the GS-algorithm to the DFM may not be judged on the base of the results of simulation obtained above. The long time of calculations (table) restricted the number of the performed simulations and consequently the following questions remain still without a unique answer.

Does the algorithm assure the convergence to the right solution? Will the algorithm be applicable to the two-dimensional case? Is the reconstruction made with this algorithm stable?

Below some premises of the positive answer to all the three questions will be given.

The reasons for the failure of reconstruction in the case of the third and fourth function (28) should be perceived in too rare sampling of these functions. In such a case the reconstruction errors may depend essentially upon the initial approximation, which has been stated in paper [16]. This fact may be exploited by using several different initial approximations of f_1^1 and choosing such solution for which the error $\varepsilon(n)$ will be the least.

The GS-algorithm may be also adapted to the two-dimensional case. The loops in fig. 1 should be completed by adding several further instructions in order to coordinate the n -th approximations with the results of the third measurement. The further widening of the algorithm may be easily imagined when more than three measurements of intensity are made at different rotations of the transparency $T_2(\omega)_0$ by the angles less than 90° . The calculation time of one loop (one iteration) will be longer but the number of iterations needed to obtain the respective accuracy will decrease.

In accordance with the results of the works [11, 17, 18] the stability of the GS-algorithm is very high. In these papers the noise-to-signal level ranging from few to several percent has been accepted as admissible. Therefore, it may be supposed that also in this method the GS-algorithm will be stable. Additionally, the stability may be arbitrarily increased taking the suitably great number of "independent" measurements of intensity performed at different positions of the transparency in the exit pupil.

The proposed way of assuring the convergence and enhancing the stability involves some elongation of the time of calculation and some increase of the occupied memory of the used computers. Hence, it follows that the discussed method (DFM) of phase reconstruction with the help of the GS-algorithm may be useful only for fast and large computers.

References

- [1] WALTHER A., *Opt. Acta* **10** (1963), 41.
- [2] PEŘINA J., *Coherence of Light*, Van Nostrand Reinhold Co., London 1971, p. 55.
- [3] BURGE R. E., et al., *Proc. R. Soc. (London)*, Sec. A350 (1976), 191.
- [4] HOENDERS B. J., *J. Math. Phys.* **16** (1975), 1719.
- [5] GREENAWAY A. H., *Opt. Lett.* **1** (1977), 10.
- [6] DRENTH A. J. J., HUISER A. M. J., FERWERDA H. A., *Opt. Acta* **22** (1975), 615.
- [7] HUISER A. H. J., FERWERDA H. A., *Opt. Acta* **23** (1976), 445.
- [8] VAN TOORN P., FERWERDA H. A., *Opt. Acta* **23** (1976), 457.
- [9] MISELL D. L., *J. Phys. D: Appl. Phys.* **6** (1973), L6.
- [10] GERCHBERG R. W., SAXTON W. O., *Optik* **35** (1972), 237.

- [11] GERCHBERG R. W., SAXTON W. O., *Image Processing and Computer-aided Design in Electron Optics*, Ed. by P. W. Hawkes, Academic Press, London 1972, pp. 66-81.
- [12] SCHISKE P., *Optik* **40** (1974), 261.
- [13] DALLAS W. J., *Optik* **44** (1975), 45.
- [14] HUISER A. M. J., DRENTH A. J. J., FERWERDA H. A., *Optik* **45** (1976), 303.
- [15] HUISER A. M. J., FERWERDA H. A., *Optik* **46** (1976), 407.
- [16] VAN TOORN P., FERWERDA H. A., *Optik* **47** (1977), 123.
- [17] FIENUP J. R., *Opt. Lett.* **3** (1978), 27.
- [18] FIENUP J. R., *Opt. Eng.*, **18** (1979), 529.
- [19] KIEDROŃ P., *Optica Applicata* **X** (1980), 149.
- [20] KIEDROŃ P., *Optica Applicata* **X** (1980), 254.
- [21] KIEDROŃ P., *Optica Applicata* **X** (1980), 483.
- [22] VAN TOORN P., *Doctor's Thesis*, State University in Groningen, 1979.
- [23] AHMED N., RAO K. R., *Orthogonal Transforms for Digital Signal Processing*, Springer-Verlag, Berlin, New York, Heidelberg 1978.

Received January 14, 1981

Стабильность реконструкции фазы из распределений интенсивностей на входе и выходе оптического дифференциального оператора

Исследован вопрос стабильности реконструкции фазы методом, заключающимся в измерении интенсивностей на входе и выходе дифференциального оператора. Такой оператор можно осуществлять посредством помещения линейного амплитудного фильтра в выходный зрачок оптической когерентной системы. Приведена имитация процесса реконструкции при применении алгоритма Герберга-Секстона.