

HENRYK MELOCH*, PIOTR KABSCH*

FILM STRUCTURE IN NOT FULLY DEVELOPED VERTICAL ANNULAR-DISPERSED FLOW

Incompleteness of the knowledge of film structure in not fully developed annular-dispersed flow is pointed out. Methodology and results of research carried out on film velocity in the development zone of the flow are presented. An equation allowing us to calculate the velocity of the film surface displacement is put forward. Our results are compared to the results reported by Taylor and Hewitt. With reference to Moalem-Maron's and Dukler's considerations, a method of calculating mean velocity and film flow rate in not fully developed vertical annular-dispersed flow is set out.

NOMENCLATURE

A_F		- film flow area (m^2),
D_A		- scrubber throat diameter (m),
g		- acceleration due to gravity (m/s^2),
l		- length of the apparatus throat (m),
$Nz = \dot{V}_l / \dot{V}_g$		- liquid to gas flow rate ratio (m^3/m^3),
p		- pressure (Pa),
t		- time (s),
\dot{V}		- flow rate (m^3/s),
w, \bar{w}		- velocity, mean velocity (m/s),
y		- coordinate of film thickness (m),
x		- distance from the liquid injection section (m).

GREEK SYMBOLS

δ_F		- film thickness (m),
η		- viscosity ($kg/(ms)$),
ρ		- density (kg/m^3),
τ_i		- interfacial shear stresses (N/m^2),
ϕ		- parameter defined by eq. (3).

* Insitute of Environment Protection Engineering, Technical University of Wrocław, pl. Grunwaldzki 9, 50-377 Wrocław, Poland.

SUBSCRIPTS

- A* - apparatus,
- c* - liquid phase,
- F* - film,
- g* - gas phase,
- i* - interface,
- min - minimal values,
- max - maximal values,
- w* - relative quantity.

1. INTRODUCTION

Annular-dispersed flow is a liquid-gas flow characterized by three phases much different from one another (figure 3), i.e. a continuous gas phase moving at high velocities (20–80 m/s), a continuous liquid phase, called film, slowly flowing at the apparatus walls (at a velocity of a few meters per second) and a dispersed liquid phase, that is droplets moving far quicker than the film, but slower than the gas phase.

The flow occurs in many apparatuses that operate on the basis of multiphase flow. Some of these apparatuses are significant for environment protection. In the field of industrial waste gases cleaning, there is an interest to be observed in making use of annular-dispersed flows for simultaneous cooling, dust collection and removal of gas pollutants.

Structure of the film flow in vertical cocurrent annular-dispersed flows directed upwards was the subject of many papers [1]–[14] and the research published by many scientific groups. Among the well-known scientists are G.F. Hewitt with his co-workers, from the Harwell National Engineering Laboratory, F. Mayinger with his co-workers, from the Institut für Verfahrenstechnik – Universität Hannover, G.A. Hughmark from the Ethyl Corporation – Louisiana, G. Zabaras and A.E. Dukler from the University of Houston and cooperating with them D. Moalem-Maron from the Tel-Aviv University.

The very last of the enumerated research groups in 1986 published a paper [16] summarizing and generalizing present state of the knowledge about the subject specified above. This publication, however, as the other papers in this domain, deals with fully developed flows. It should be stressed that no comprehensive publications about film structure in the development zone of the annular-dispersed flow have hitherto appeared.

2. FILM VELOCITY AT INTERFACE

As far as the most interesting applications of annular-dispersed flows are concerned, i.e. mass and heat transfer processes, only the following parameters characterizing film are crucial: its interfacial area with gas and its velocity at the interface w_{Fi} . The latter could be estimated only on the basis of a proper experiment [15].

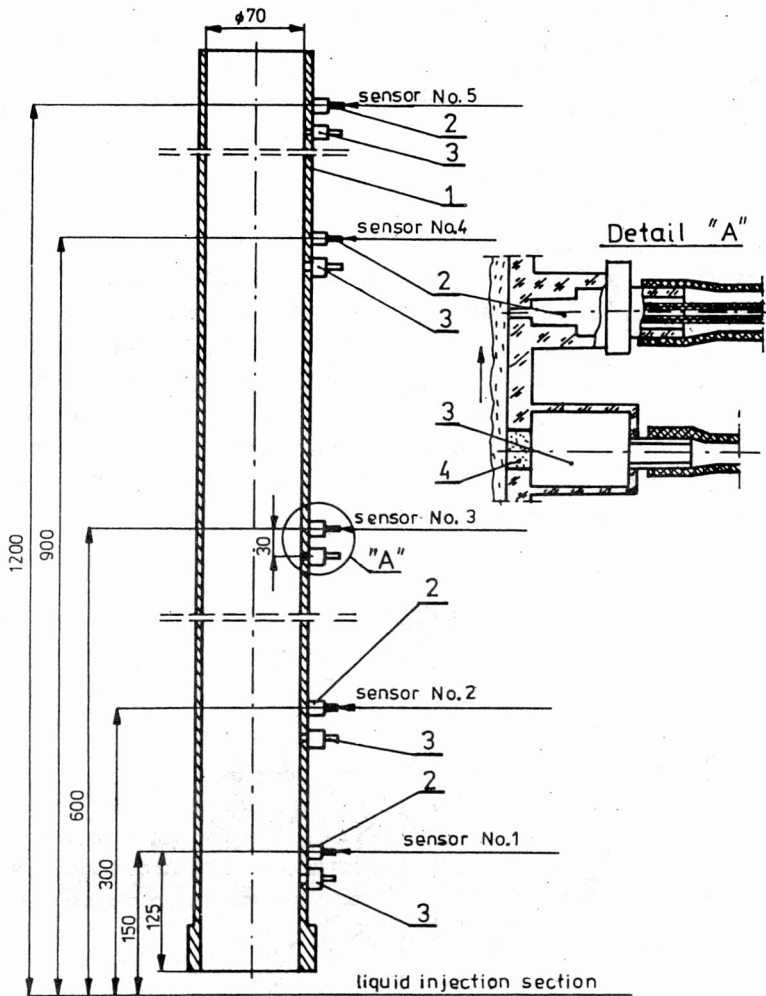

Fig. 1. Arrangement of conductometric sensors and stubs for proportioning the tracer in the scrubber throat of 70 mm in diameter

Film velocity values were estimated by measuring the length of the periods of time during which liquid elements were shifted at some distance between the apparatus sections. The idea of the measurement technique applied consisted in film marking with a tracer (in the form of electrolyte) and registering periods of time of the increase in film conductance in the selected measurement sections. Such a technique, along with simultaneous availability of adequate equipment, allowed one to achieve very high measurement accuracy, as the time was the quantity measured directly. Interimpulse times were measured with accuracy of 10^{-1} ms.

Placements of both conductometric sensors and stubs for tracer proportioning were shown by example of a pipe of 70 mm in diameter (figure 1). In the lower part of the figure, there is presented a section where liquid injection to gas stream took place. The dispersed liquid, partly in the form of droplets and partly in the form of film flowing at the walls of the pipe, was moving along with gas from the bottom upwards. On the outer surface of the wall, five sets consisting of a proportioning stub 3 and a conductance sensor 2 were installed. It gave an opportunity to measure the time in which there occurs the displacement of liquid film between arbitrary measurement sections of the throat 1. For instance, proportioning of the tracer from the bottom by means of the first stub enables time measurement of film displacement between sensors 1 and 2. Detail "A" (figure 1) illustrates the way the proportioning stubs and the conductometric sensor have been fixed. The tracer is supplied to the flowing film through a porous wall 5 made of methyl polymethacrylate sinter. The purpose is to introduce the sufficient tracer volumes preserving minimal velocities of its outflow in order not to disturb the film flow itself and preserve tracer droplets from penetration into gas stream.

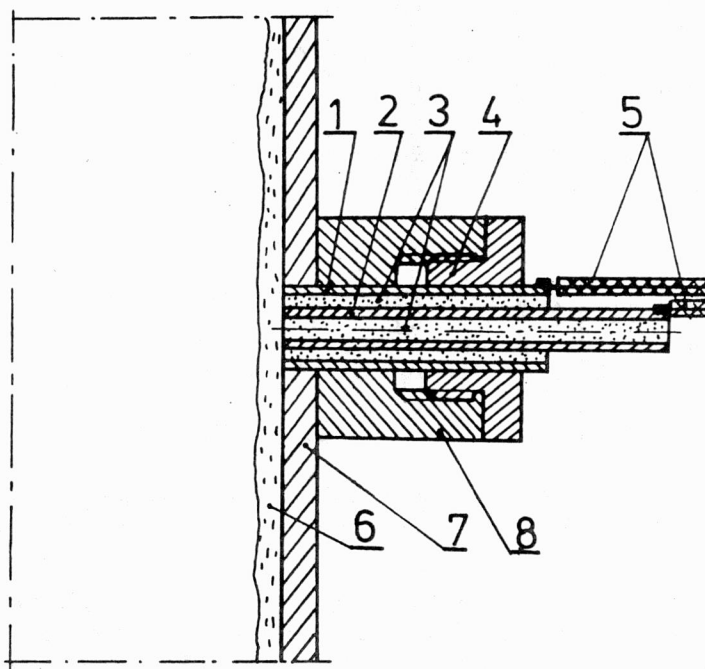

Fig. 2. The structure of a conductometric sensor for testing the film movement velocity
 1 - outer electrode, 2 - inner electrode, 3 - epoxy resin insulation, 4 - sensor fitting,
 5 - electric wiring, 6 - liquid film, 7 - throat wall, 8 - sensor seat

In figure 2, the structure of the conductometric sensor and the way it is fixed in the throat wall are presented in detail.

As the objective of the research was to estimate the liquid film velocity at the interface, it was indispensable to plan an experiment in a manner allowing us to reach the aim. So let us have a look at a profile of film and gas phase velocity in vertical cocurrent annular-dispersed flow directed upwards (figure 3). From the figure it is evident that in order to measure the time of displacement of elements on the liquid surface (they move fastest), one should register moments when the increase of conductance begins.

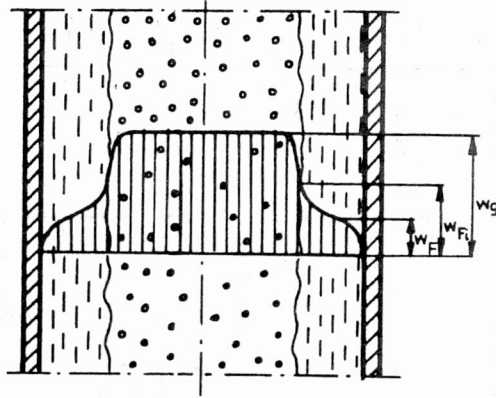

Fig. 3. Cross-wise profile of film and gaseous phase velocities in upwards-directed cocurrent annular-dispersed flow

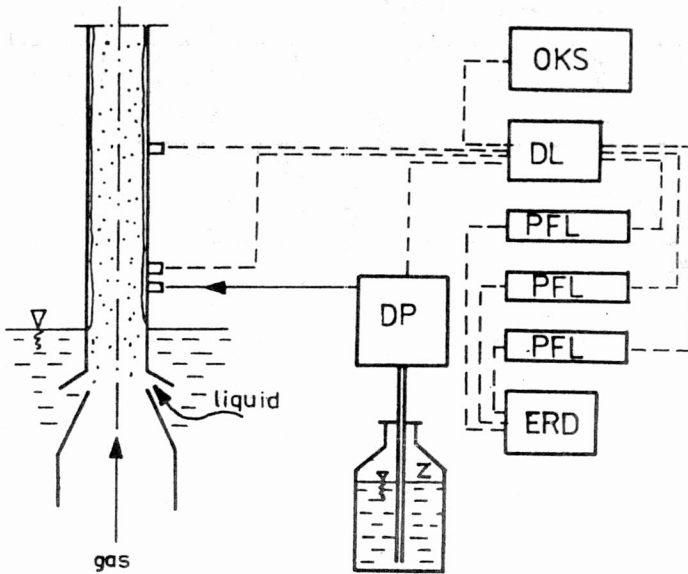

Fig. 4. A diagram of the system for testing the film surface movement velocity

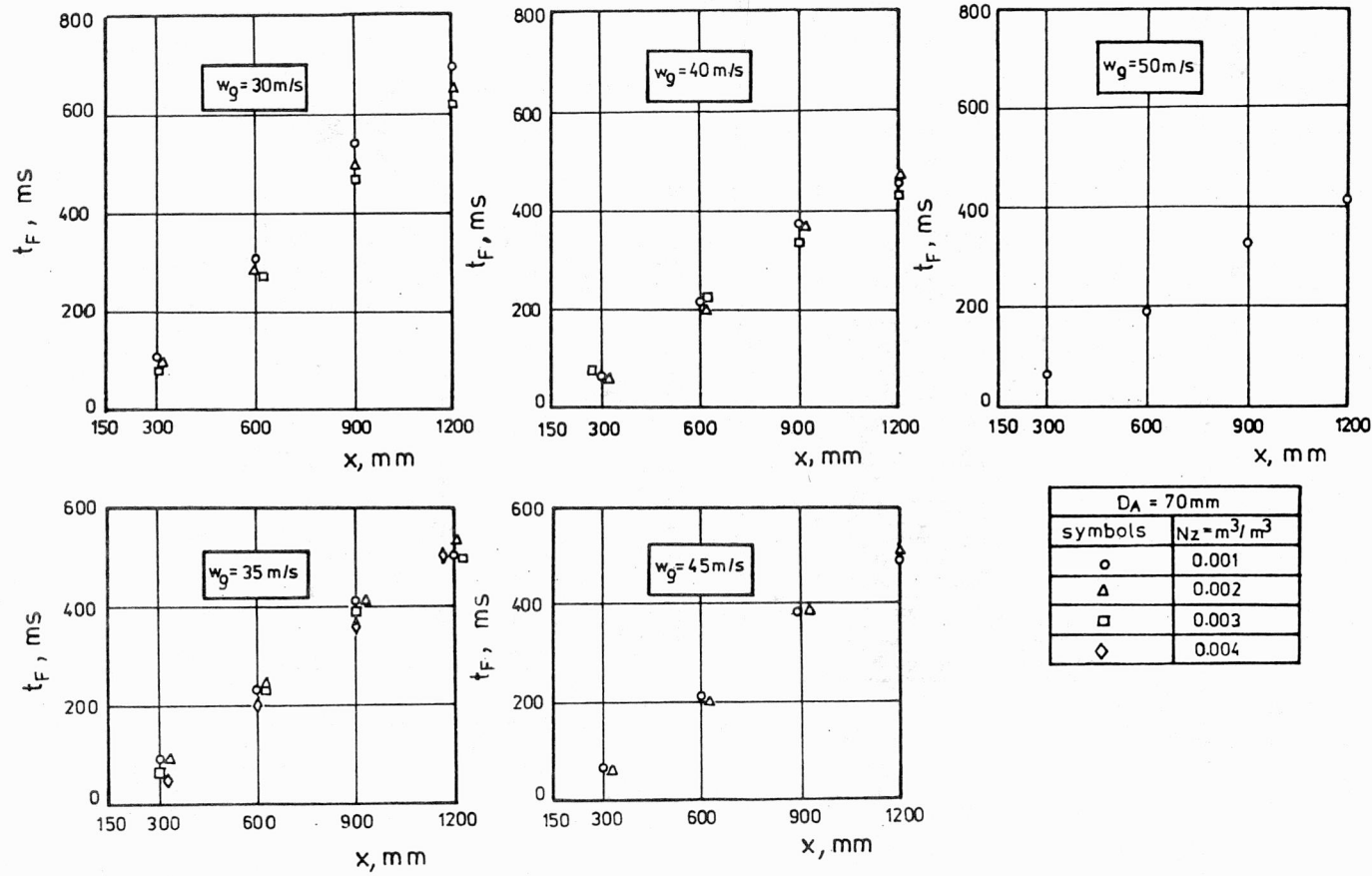

Fig. 5. Exemplary measurements of the time of liquid film displacement at the interface

In figure 4, there is presented a diagram of a measurement system consisting of a programmable tracer dispenser DP, a detection-logical block DL (specially designed and made), frequency and time meters PFL, digital recorder ERD and oscilloscope OKS. A detailed description of the applied investigation techniques, structure and operation rudiments of the measuring equipment were presented by MELOCH and his co-workers in the papers [15] and [17]–[20].

Investigations were carried out in an injection scrubber with three exchangeable throats (pipes), 26, 50 and 70 mm in diameter and respectively 448, 856 and 1200 mm in length.

Exemplary time measurement results of displacement of liquid film elements at the interface in the injection scrubber throat, depending on hydrodynamic operation conditions of the apparatus, are presented in figure 5. An analysis of the dependence $t_F = f(x)$ presented in figure 5 confirms the conviction that film velocities do not depend on the distance x between the examined section of the apparatus and the liquid injection section. They are not dependent either on the liquid to gas flow rate ratio Nz , but they are practically the function of gas phase flow velocity w_g and throat diameter D_A . Thus, the measurement results presented in figure 5 were approximated by means of linear equations. The regression ratios of the equation $t_F = bx$ were the inverse of film velocity at the interface $w_{Fi} = x/t_F = b^{-1}$. Further analysis of the experiment results gave the following dependence:

$$w_{Fi} = (-2.953 \cdot 10^3 D_A^3 + 3.52) \sqrt{\ln(0.05 w_g)}. \quad (1)$$

The results of the experiment lead to conclusion that there exist considerable differences in the movement of film and liquid droplets. The latter move along the throat with accelerated motion, whereas in the case of film, the equilibrium between liquid friction against the wall and aerodynamic forces is achieved almost immediately behind the liquid injection section. These observations make it possible to assume that the film phase during development of annular-dispersed flow is similar to the film in the zone of fully developed flow, obviously except for fluctuation of its thickness δ_F (and thus of its mean velocity \bar{w}_F). In order to confirm this assumption, at least partially, we should refer to the results of extensive experimental works published by TAYLOR and HEWITT in 1963 [21]. They examined very carefully the dependence of velocity of film waves (i.e. film velocity at interface \bar{w}_{Fi}) on the gas velocity w_g and the liquid to gas flow rate ratio Nz in the pipe of 31 mm in diameter and longer than 6 m, which resulted in the relation $l_{\max}/D_A \approx 200$. The measurements were carried out in the zone of fully developed flow, i.e. above a section whose distance from the liquid injection section was 2.44 m, which resulted in the relation $l_{\max}/D_A \approx 80$. The velocity was measured photographically and conductometrically. From the analysis of the investigation results it was evident that the film velocity at the interface did not depend on liquid to gas flow ratio either, and that, in fact, it was constant within the whole

length of the apparatus. Velocities of film waves measured by Hewitt approximated to those obtained herein, though they referred to the zone of fully developed annular-dispersed flow (figure 6).

Acceleration of droplets formed from film as well as heat and mass transfer in the injection scrubber depend on the relative velocities of the film surface w_{wFi} and the gas phase core. In figure 7, there is presented a comparison of relative velocities calculated by means of equation (1) and calculated on the basis of Taylor and Hewitt's experiment. To sum up: there is a considerable analogy between the film in the zone of annular-dispersed flow development and the film in the zone of fully developed flow.

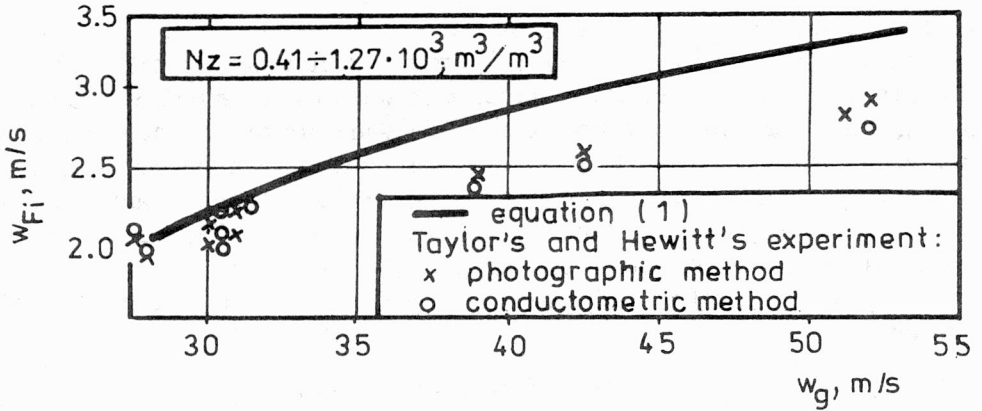

Fig. 6. A comparison of the film surface velocity calculated according to equation (1) and measured by TAYLOR and HEWITT [21]

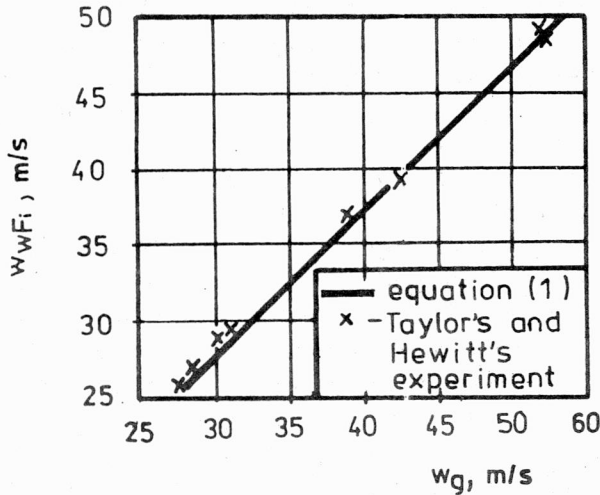

Fig. 7. A comparison of the film surface velocity in relation to the gas calculated according to equation (1) and measured by TAYLOR and HEWITT [21]

3. MEAN FILM VELOCITY

Taking into account the measurement results of film velocity at the interface w_{Fi} , it can be presumed that almost immediately behind the liquid injection section, the flow development takes place and a definite transverse profile of liquid velocity in film becomes fixed. In 1984, MOALEM-MARON and DUKLER [22] presented equation of the film velocity profile in the following form

$$w_F(y) = \frac{\rho_c \phi g}{\eta_c} \left[\left(\delta_F - \frac{\tau_i}{\rho_c g \phi} \right) y - \frac{y^2}{2} \right] \quad (2)$$

where:

$$\phi = \frac{g - \frac{1}{\rho_c} \frac{dp}{dx}}{g} \quad (3)$$

on the basis of which the formula of the mean velocity \bar{w}_F can be derived

$$\bar{w}_F = \frac{1}{\delta_F} \int_0^{\delta_F} w_F(y) dy. \quad (4)$$

After substitution and integration one gets

$$\bar{w}_F = \frac{\delta_F}{\eta_c} \left(\frac{\rho_c \phi g}{3} \delta_F - \frac{\tau_i}{2} \right). \quad (5)$$

Moreover, on the basis of (2) we can arrive at the equation

$$w_{Fi} = w_F(\delta_F) = \frac{\rho_c \phi g \delta_F}{\eta_c} \left(-\frac{\tau_i}{\rho_c \phi g} + \frac{\delta_F}{2} \right) \quad (6)$$

where w_{Fi} is the already known film velocity at interface. It is also known that the film flow rate can be described by the following equation

$$\dot{V}_F = \bar{w}_F A_F = \bar{w}_F \left[\frac{\pi D_A^2}{4} - \frac{\pi}{4} (D_A - 2\delta_F)^2 \right]. \quad (7)$$

Thus dependences (5), (6) and (7) form a solvable system of equations with three unknown quantities \bar{w}_F , δ_F and dp/dx . It allows one to calculate the mean film velocity and then to determine the time of film shift and values of its hold-up.

4. SUMMARY

An analysis of theoretical and experimental works leads to the conclusion that the knowledge of the film structure in not fully developed annular-dispersed flow is relatively poor. Investigations carried out by us allow the conclusion that in the zone

of the flow development, the film shift only slightly differs from that occurring in the fully developed flow. The film surface velocity approximates to the analogical velocity in the developed flow and, similarly, it does not depend on the liquid to gas flow rate ratio Nz and the distance x from the injection section. Both compared velocities, however, depend on the gas phase velocity and the apparatus diameter. Analogies between the film in developed and in undeveloped flows, which have been confirmed by comparison of our experiment results with these reported by TAYLOR and HEWITT [21], allow us to apply the Moalem-Maron and Dukler's equation (2) with certain approximation [22] to calculation of mean film velocity in the zone of the annular-dispersed flow development. It is of great importance for estimation of the liquid hold-up value and interfacial area in many apparatuses used in environment protection.

LITERATURE

- [1] BUTTERWORTH D., HEWITT G.F., *Two-Phase Flow and Heat Transfer*, United Kingdom Atomic Energy Authority Research Group, Oxford University Press, 1977.
- [2] MAYINGER F., *Strömung und Wärmeübergang in Gas-Flüssigkeits Gemischen*, Springer-Verlag, Wien 1982.
- [3] BRAUER H., *Grundlagen der Einphasen und Mehrphasenströmungen*, Verlag Sauerländer, Frankfurt am Main 1971.
- [4] WALLIS G.B., *One-Dimensional Two-Phase Flow*, McGraw-Hill Book Company, 1969.
- [5] TAKAHAMA H., OKADA O., FUJITA H., MIZUNO A., *Study on Annular Mist Flow in Pipe*, Bull. JSME, 26, 222, pp. 2091–2099, 1983.
- [6] UEDA T., TANAKA T., *Studies of Liquid Film Flow in Two-Phase Annular and Annular-Mist Flow Regions*, Bull. JSME, 17, 107, pp. 603–613, 1974.
- [7] SZE-FOO CHIEN, IBELE W., *Pressure Drop and Liquid Film Thickness of Two-Phase Annular and Annular-Mist Flows*, Trans. ASME J. Heat Transfer, 2, pp. 89–96, 1964.
- [8] HENSTOCK W.H., HANRATTY T.J., *The Interfacial Drag and the Height of the Wall Layer in Annular Flows*, AIChE J., 22, 6, pp. 990–1000, 1976.
- [9] ANDREUSSI P., ASALI J.C., HANRATTY T.J., *Initiation of Roll Waves in Gas-Liquid Flows*, AIChE J., 31, 1, pp. 119–126, 1985.
- [10] GILL L.E., HEWITT G.F., LACEY P.M.C., *Studies of the Effect of Phase Flow Rates on Phase and Velocity Distribution*, Chem. Eng. Sci., 19, pp. 665–682, 1964.
- [11] ASALI J.C., HANRATTY T.J., ANDREUSSI P., *Interfacial Drag and Film Height for Vertical Annular Flow*, AIChE J., 31, 6, pp. 895–902, 1985.
- [12] SPINDLER B., SOLESIO J.N., DELHAYE J.M., *On the Equations Describing the Instabilities of Liquid Films with Interfacial Phase Change*, International Seminar "Momentum, Heat and Mass Transfer in Two-Phase Energy and Chemical Systems", Dubrownik 1978.
- [13] HEWITT G.F., *Disturbance Waves in Annular Two-Phase Flow*, Proc. Instn. Mech. Engrs., 184, pp. 142–150, 1970.
- [14] JAGOTA A.K., RHODES E., SCOTT D.S., *Measurement of Residence Times and Film and Drop Velocities in Two-Phase Annular Flow*, Can. J. Chem. Eng., 51, pp. 393–400, 1973.
- [15] MELOCH H., CYBULSKA H., KNOP F., RYDOSZ K., *Investigation of Liquid Film Movement Parameters in the Injection Contactor in the Range of High Gaseous Phase Velocities* (in Polish), Reports of the Institute of Environment Protection Engineering, Technical University of Wrocław, series SPR No. 67/87, Wrocław 1987.
- [16] ZABARAS G., DUKLER A.E., MAOLEM-MARON D., *Vertical Upward Cocurrent Gas-Liquid Annular Flow*, AIChE J., 32, 5, pp. 829–843, 1986.

- [17] MELOCH H., KNOP F., OSTROPOLSKI W., *Elaboration of New Method of Liquid Hold-Up Measurement in High-Velocity Absorber on Example of the Injection Contactor* (in Polish), Reports of the Institute of Environment Protection Engineering, Technical University of Wrocław, series SPR No. 31/83, Wrocław 1983.
- [18] MELOCH H., *Investigation of Liquid Phase Elements Movement and Liquid Hold-Up in the Injection Contactor* (in Polish), Reports of the Institute of Environment Protection Engineering, Technical University of Wrocław, series SPR No. 64/84, Wrocław 1984.
- [19] MELOCH H., KNOP F., *Investigation of Liquid Phase Elements Movement and Liquid Hold-Up in the Injection Contactor* (in Polish), Reports of the Institute of Environment Protection Engineering, Technical University of Wrocław, series SPR No. 5/86, Wrocław 1986.
- [20] MELOCH H., KABSCH P., KNOP F., KACZMARSKI K., *Measurement Method of the Selected Parameters of Annular-Dispersed Flows* (in Polish), The Third National Seminar – Fluid Mechanics Application in Environment Protection, Wisła 1988 (Poland).
- [21] TAYLOR N.H., HEWITT G.F., LACEY P.M.C., *The Motion and Frequency of Large Disturbance Waves in Annular Two-Phase Flow of Air-Water Mixtures*, Chem. Eng. Sci., 18, pp. 537, 1963.
- [22] MOALEM-MARON D., DUKLER A.E., *Flooding and Upward Film Flow in Vertical Tubes*, Int. J. Multiphase Flow, 10, pp. 599–608, 1984.

STRUKTURA FILMU W NIEROZWINIĘTYM PIONOWYM PRZEPLYWIE PIERŚCIENIOWO-DYSPERSYJNYM

Wskazano na niekompletność danych na temat struktury filmu w nierozwiniętym przepływie pierścieniowo-dyspersyjnym. Przedstawiono metodykę oraz wyniki badań prędkości filmu w strefie rozwijania się takiego przepływu. Zaproponowano równanie umożliwiające obliczanie prędkości przemieszczania się powierzchni filmu. Rezultaty własnych badań porównano z wynikami eksperymentów przeprowadzonych przez Taylora i Hewitta. Nawiązując do rozważań Moalem-Marona i Duklera, zaproponowano metodę obliczania średniej prędkości oraz strumienia objętości filmu w nierozwiniętym pionowym przepływie pierścieniowo-dyspersyjnym.

СТРУКТУРА ФИЛЬМА В НЕРАЗВИТОМ ВЕРТИКАЛЬНОМ ЦИКЛИЧНО-ДИСПЕРСИОННОМ ТЕЧЕНИИ

Обнаружен недостаток данных на тему структуры фильма в неразвитом циклично-дисперсионном течении. Представлены методика, а также результаты исследований скорости фильма в зоне развития такого течения. Предложено уравнение, дающее возможность рассчитать скорость продвижения поверхности фильма. Результаты собственных исследований сравнены с результатами экспериментов, проведенных Тейлором и Гевиттом. Ссылаясь на рассуждения Моалем-Марона и Дуклера, предложили метод расчета средней скорости, а также потока объема фильма в неразвитом вертикальном циклично-дисперсионном течении.

