

# **Interference measurements of prism optics for laser interferometer**

JIŘI KŘSEK

Institute of Scientific Instruments of the Czechoslovak Academy of Sciences, Brno, Czechoslovakia.

Perfect testing of optical prism elements for a laser interferometer is based on interference measuring methods complying with strict requirements concerning the choice of optical elements for systems of coherence optics. Interference testing methods for measurements of the absolute angular deviation of optical surfaces forming the right angle and measurements of corner-cube prisms with the unambiguous determination of the angular deviation of the functional part of individual sectors of the measured prism are described.

## **Introduction**

The development of light quantum generators and their applications in several scientific and industrial branches has created new, more exacting requirements in relation to the existing, traditional, production of optical elements. The required, more precise production of optical elements with a tolerance field of the order of units of angular seconds brings with it also the increased requirements concerning their testing. Geometry measurements of functional surfaces of optical unit elements for a laser interferometer cannot well do without interference testing methods, which usually are at the boundary of the required accuracy. For this reason, new methods of the interference testing of optical elements allowing higher resolution and accuracy in reading off the deviations are sought for.

## **Interference measurements of rectangular prisms and cubes**

The optical arrangement of an interferometer for the measurements of the absolute angular deviations, forming the right angle, can be seen in fig. 1. In principle, this is a combination of the Michelson interferometer with the Fabry-Pérot interferometer [1, 2]. The measuring method is based on the double reflection of a beam of rays from the object to be measured 3, and on the interference of two partial measuring beams of rays with a single reference beam. For the angular deviation  $\varepsilon$  of a rectangular cube, according to fig. 1, the following relations is valid :

$$\varepsilon = \frac{\beta}{4} \pm \frac{\xi}{2}, \quad (1)$$

where:  $\beta$  — the angle between the interfering beams of rays,

$\xi$  — the angle between the functional surfaces of the plane mirrors 4 and 5.

It is clear from the eq. (1), that the accuracy of the adjustment mirrors 4 and 5 has a substantial influence on the determination of the absolute deviation  $\varepsilon$ . The

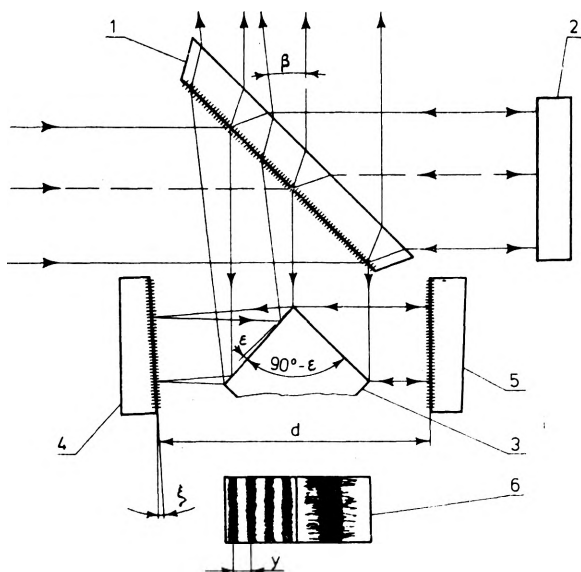

Fig. 1. Optical diagram of an interferometer for the measurements of the absolute angular deviation of polished surfaces forming the right angles :

1 — se.mi-transparent dividing plate, 2 — reference planar mirror, 3 — rectangular cube to be measured, 4, 5 — planar mirrors of the Fabry-Pérot interferometer, 6 — interferogram of measured surfaces

angular deviation  $\beta$  of the interfering beams of rays is determined from the spacing  $y$  of the interference fringes by the expression :

$$\beta = \frac{\lambda}{y}, \quad (2)$$

where  $\lambda$  — wavelength of the light.

The absolute reading of this angular deviation is given by the fact, that the right-hand side and also the left-hand side of the interference field 6 originate from a single plane surface of the reference mirror 2.

After adjusting the parallelity of the functional surfaces of the plane mirrors 4 and 5 of the Fabry-Pérot interferometer, the object to be measured is placed between these mirrors so that one functional reflection surface shows a zero number of interference fringes with the plane surface of the reference mirror 2. The second functional surface of the object to be measured is so adjusted, that the direction of the interference fringes is parallel to the line of intersection of the measured surfaces. In this case the number of interference fringes is minimum and the angular deviation is made apparent by the interference of measuring and reference beams of rays, forming the angle  $\beta$ . The sense of the angular deviation is determined from the shift of the interference fringes at the relative change of the optical paths of the interfering wavefronts. When the fringes, whilst shortening the difference of the optical path, are shifting towards the line of intersection of the surface to be measured,

then this is a positive deviation  $\varepsilon$ , and if they are shifting from the line of intersection, then it is a negative deviation  $\varepsilon$ .

The increase of accuracy and resolving power in the measurements of the absolute angular deviation of surfaces forming the right angle is achieved by tilting the surfaces to be measured about their line of intersection, when two systems of interference fringes are formed on the optical wedge, having the spacings  $y_1$  and  $y_2$ . The angular deviation is then given by the expression

$$\varepsilon = \frac{\lambda(y_1 - y_2)}{4 \cdot y_1 \cdot y_2} \pm \frac{\xi}{2}, \quad (3)$$

which enables us to evaluate even very small angular deviations up to the limiting resolution given by the area of reference fields. This limiting resolution can have the value of  $\pm 0.02$  angular seconds, for instance, for the basic 10 mm spacing of interference fringes measured by an Abbe comparator with an accuracy of  $\pm 0.01$  mm.

## Interference measurements of cube-corner reflectors

The interference measurements of the total deformation of the plane wavefront and of the angular deviation  $\delta$  of rays passing through a corner-cube prism are carried out with the help of a collimated laser beam, the acquired interferograms are then the determining factors of the retroreflector applicability.

The interference measurements of corner-cube prisms can be made in principle by two methods:

a) observation or recording of the so-called "dead fringes", resulting from the interference of rays, reflected from the front surface of the prism [3].

b) observation or recording and evaluation of the so-called "live fringes", arising as a consequence of the interference of beams reflected from the two-sides of the auxiliary plano-parallel mirror and from the reference plane gage [4].

The principle of the measuring method according to a) is shown in fig. 2, where the plane front surface of a corner-cube prism measured in advance serves as a reference plane. If one half of the prism is screened off during the measurement, the interference of the wavefronts results due to the reflection from the front the plane surface of the prism, enclosed between the rays directly reflected and those passed through the prism. In this case of a double passage of rays through the prism, the spacing  $\Delta y$  of the interference fringes corresponds to the double angle of the rays drift and the required functional angular deviation of the corner-cube prism is determined according to the equation:

$$\delta = \frac{\lambda}{2 \cdot \Delta y}. \quad (4)$$

This measuring method provides only some qualitative information, as it does not allow to determine angular deviations. However, it is advantageous since the quality of the whole prism — that is of all the three sectors — is recorded on a single

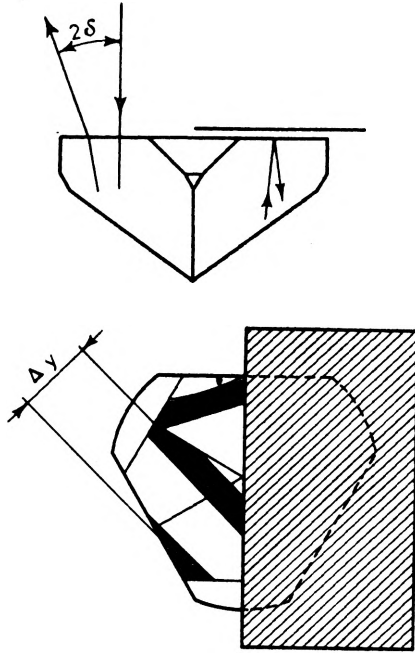

Fig. 2. The principle of the interference measurements of angular deviations of a corner-cube prism by the method of "dead fringes"

interferogram. Typical interferograms of several corner-cube prisms of different qualities are shown in fig. 3a, b, c.

The principle of the measuring method according to b) is shown in fig. 4. In this measuring method the measuring and reference beams of rays are reflected by several independent optical elements and thus the so-called "live fringes" are formed, when the optical paths difference changes, enabling in this way to determine both the amount and the direction of the angular deviation. The measuring method is based on the fact that between the corner-cube prism 3 and the reference plane gauge 2 an auxiliary plano-parallel mirror 4 is inserted into one half of the prism field of view. The lower surface of this mirror returns the rays through the prism in the primary direction and the upper surface determines the value and the direction of the angular deviation. In this case, the interference field within the prism sector 5.1 will be dark or light, according to the set difference between optical paths of the measuring and reference beams. On the upper surface of the mirror interference fringes 5.2 will be formed indicating the value and the direction of the angular deviation. The value of the angular deviation of one of the three sectors of a corner-cube prism is determined according to the eq. (4), and the direction of the deviation is determined from the shift direction of interference fringes with the relative change of optical paths difference of the interfering rays. The resolving power of this measuring methods is limited by the area of the auxiliary plano-parallel mirror and by the accuracy of the reverse shift setting of rays through the prism. The last value of angular deviation  $\delta$  obtainable by the measuring device with a plano-parallel mirror of 50 mm diameter used in the Institute of Scientific Instruments is 1-2 an-

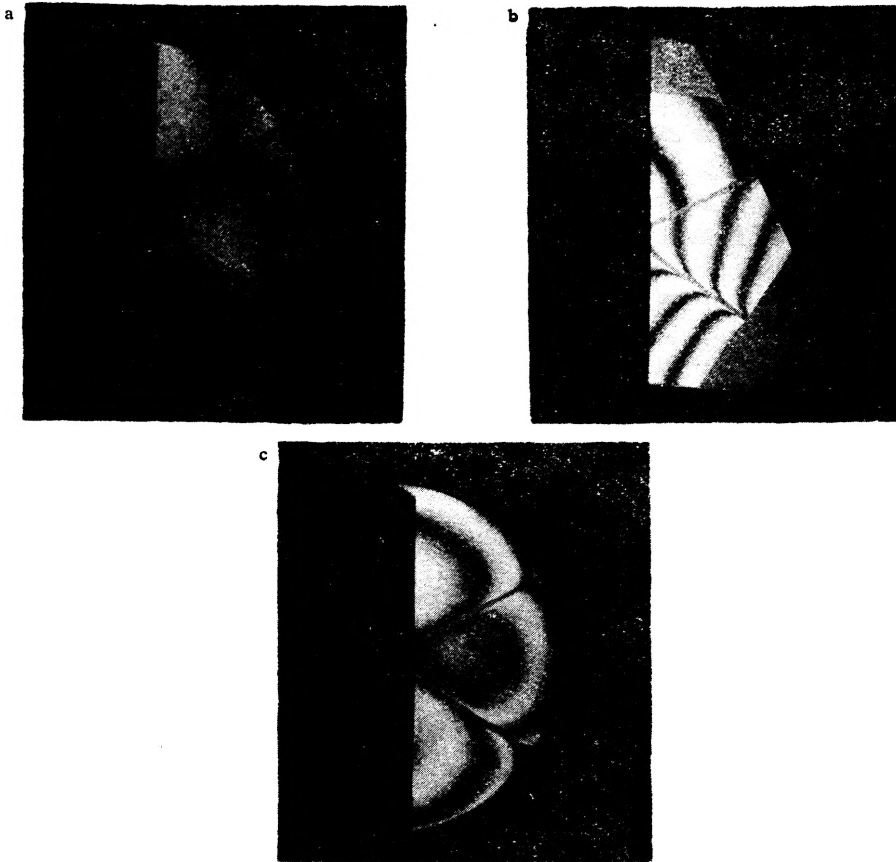

Fig. 3. Interferograms of corner-cube prisms showing the angular deviations of all three prism sector

angular second. The accuracy of the setting of the zero number of the interference fringes for the back travel of beams via the measured sector of a corner-cube prism is affected by the total resulting deformation of the plane wavefront. For an aperture of 12 mm diameter of the measured set of prisms it ranged from  $\lambda/10$  to  $\lambda/25$ . This error of the basic setting appeared as a resulting error of the angular deviation of the measured sector of a corner-cube prism and for extreme setting its maximum value was  $\pm 0.3$  angular seconds. The interferograms of all three sectors of a corner-cube prism shown in fig. 3a are indicated in fig. 5 (a, b, c) with the values of angular deviations of individual sectors as follows:

$$\delta_a = (4.2 \pm 0.3) \text{ angular second,}$$

$$\delta_b = (3.5 \pm 0.3) \text{ angular second,}$$

$$\delta_c = (4.0 \pm 0.3) \text{ angular second.}$$

The increase of the resolving power and accuracy of the reading of even very small angular deviations can be achieved by the formation of an additive optical wedge; this allows to determine the value and direction of an angular deviation

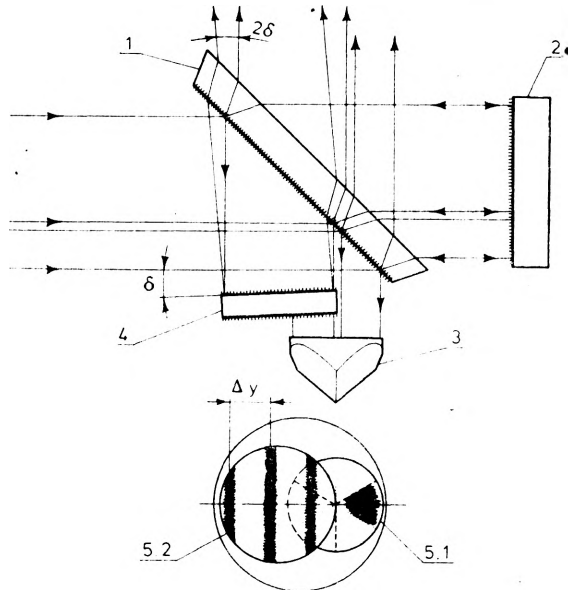

Fig. 4. The principle of interference measurements of the angular deviation of a single sector of a corner-cube prism by the method of "live fringes":

1 — semi-transparent dividing plate, 2 — reference planar mirror, 3 — corner-cube prism, 4 — auxiliary plano-parallel mirror, 5.1 — interference field within the prism sector, 5.2 — interference field on the auxiliary plano-parallel mirror

of a corner-cube prism by using additional mathematical evaluations. According to this method two interference fields of different spacing and orientation of interference fringes are formed for each sector of a corner-cube prism. For an easy orientation a rectangular coordinates introduced in such a way that the  $x$ -axis halves the prism sector, the  $y$  axis is identical with the projection of intersection lines of reflecting surfaces of a corner-cube prism and the  $z$  axis is identical with the optical axis of the observation system. The direction of the interference fringes within the prism sector is set parallel to the  $y$  axis. The interference fields formed in this way is schematically shown in fig. 6.

The resulting interference fields are given by three wavefronts that determine two planes  $\sigma$  and  $\tau$  in the coordinate system to evaluate the angular deviation of a corner-cube prism. The plane  $\sigma$  of the interference field within the prism sector is parallel to the  $y$  axis, the plane  $\tau$  of the interference field on the auxiliary mirror has a general position. The interference in fig. 7 allow to determine the angles  $\gamma_\sigma$  and  $\gamma_\tau$  between the normal lines both planes and the  $z$  axis and to read out the angle of the orientation  $\alpha$  of the normal line projection of the plane  $\tau$ .

The direction angles  $\gamma_\sigma$  and  $\gamma_\tau$  of the normal lines are calculated from the relations:

$$\gamma_\sigma = \frac{\lambda}{y_\sigma}, \quad (5)$$



Fig. 5. Interferograms of a corner-cube prism shown in fig. 3a with the angular deviations of individual sectors

$$\gamma_{\tau} = \frac{\lambda}{y_{\tau}}, \quad (6)$$

where:  $y_{\sigma}$  — the spacing of interference fringes of the plane  $\sigma$ ,  
 $y_{\tau}$  — the spacing of interference fringes of the plane  $\tau$ .

In order to determine the actual value of the angular deviation  $\delta$  and the actual orientation  $\alpha'$  of a corner-cube prism, the whole system must be turned by the angle  $\gamma_{\sigma}$  so that the normal line of the plane  $\sigma$  coincide with the positive  $z$  axis. The principle of the solution is apparent from fig. 8, where the normal lines of wavefronts  $\sigma$  and  $\tau$  with the direction angles  $\gamma_{\sigma}$  and  $\gamma_{\tau}$  and the orientation  $\alpha$  are indicated on unit

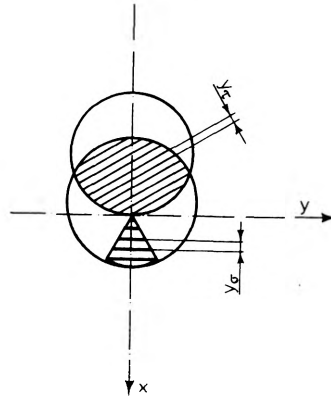

Fig. 6. Diagram of the interference field of a sector of corner-cube prism with the optical wedge added for numerical evaluation of angular deviation

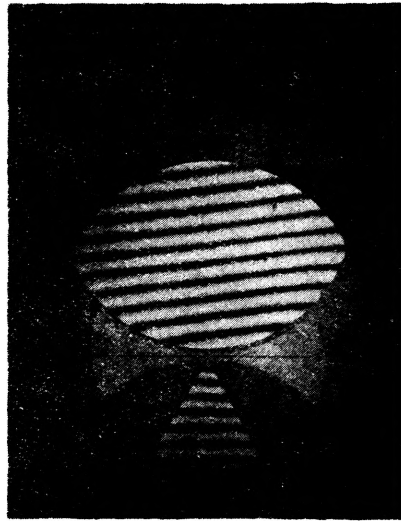

Fig. 7. Interferogram of the interference field on the auxiliary mirror and within the sector of corner-cube prism with the optical wedge

circle. When turning the system about the  $y$  axis by the angle  $\gamma_\sigma$ , the projection of the terminal point  $S_{xy}$  of the normal line of the plane  $\sigma$  coincides with the origin of coordinates and the projection of the terminal point  $T_{xy}$  of the normal line of the plane  $\tau$  is shifted to the point  $T'_{xy}$ . By tilting the unit vector of the plane  $\tau$  to the plane  $xy$ , it is possible to read out the actual value of angles  $\gamma'_\tau$  and  $\gamma$ , whilst the angular deviation of the corner-cube prism  $\delta = \gamma'_\tau/2$ .

The mathematical expression of actual direction angles of the functional deviation of a corner-cube prism is obtained by the space transformation of rectangular coordinates by the angle  $\gamma_\sigma$  [5]. The resulting forms of these functions are as follows:



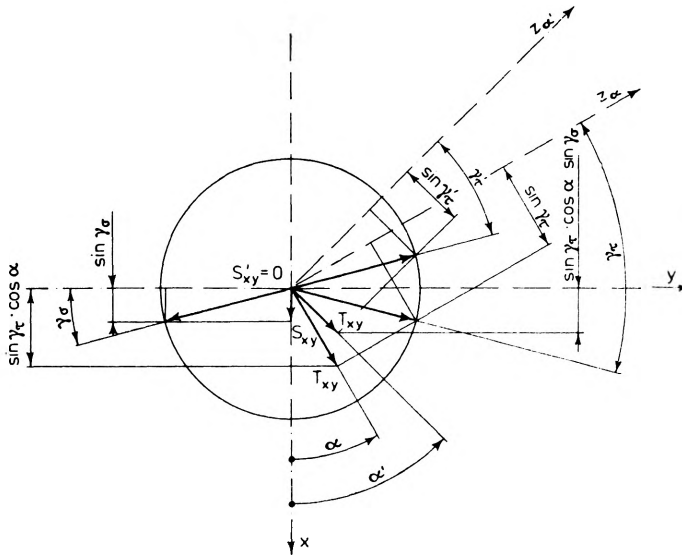

Fig. 8. A plot of angular deviations

$$\tan \alpha' = \frac{\sin \alpha \cdot \sin \gamma_\tau}{\sin \gamma_\tau \cos \alpha \cos \gamma_\sigma - \sin \gamma_\sigma \cos \gamma_\tau}, \tag{7}$$

$$\sin \gamma'_\tau = \frac{\sin \alpha \cdot \sin \gamma_\tau}{\sin \alpha'}. \tag{8}$$

As the interfering wavefronts subtend only small angles in eq. (7), it is then possible to write  $\cos \gamma_\sigma \cong \cos \gamma_\tau \cong 1$  and to determine the orientation of the functional deviation of a corner-cube prism by the angle

$$\alpha' = \tan^{-1} = \frac{\sin \alpha \cdot \sin \gamma_\tau}{\sin \gamma_\tau \cdot \cos \alpha - \sin \gamma_\sigma} \tag{9}$$

and the value of the functional deviation by the angle

$$\gamma'_\tau = \sin^{-1} = \frac{\sin \alpha \cdot \sin \gamma_\tau}{\sin \alpha'}. \tag{10}$$

The advantage of this measuring method lies in the fact that it allows to determine even the zero deviation of a corner-cube prism at which the spacing and the orientation of the interference fringes in both fields are exactly the same. The spacing of interference fringes in photographic recordings of both interference fields can be measured by mean of an Abbe comparator with an accuracy of  $\pm 0.01$  mm. This corresponds to angular resolution of  $\pm 0.04$  angular seconds of direction angles of normals  $\gamma_\sigma$  and  $\gamma_\tau$  for the wavelength  $\lambda = 632.8$  nm, the chosen spacing of interference fringes being 6 mm.

While determining the direction of an angular deviation of a corner-cube prism, it is necessary to set always the same direction of the optical wedge, this direction being determined from the shift of the interference fringes for the selected change of the optical paths difference of the interfering rays.

## Conclusion

The above described interference measuring methods were motivated by problems encountered in the course of testing of a particular laser interferometer, but the solution may prove to be general enough to allow wider application.

## References

- [1] BORN M., WOLF E., *Principles of Optics*, Pergamon Press, London 1959, pp. 299-302.
- [2] НЕЧТ Е., ЗАЈАС А., *Optics*, Addison-Wesley Publishing Co., Reading, Massachusetts 1974, p. 307-309.
- [3] KRŠEK J., *Acta Polytechnica CVUT Praha*, **11** (1976) 51-60 (in Czech).
- [4] KRŠEK J., JÁKL M., RADOŠ F., *Interference Measurements of Corner-Cube Prisms*, Research Report UPT CSAV Brno 1977 (in Czech).
- [5] РЕКТОРЫС К. et al., *Review of Applied Mathematics*, SNTL, Praha 1963, pp. 197-198 (in Czech).

Received, November 27, 1978

## Интерференционные измерения оптических призматических элементов для лазерного интерферометра

Совершенное тестирование оптических призматических элементов для лазерного интерферометра основано на интерференционных методах измерения, которые удовлетворяют строгие требования, обязательные во время подбора оптических элементов для когерентных систем. Приведены интерференционные методы тестирования, применяемые во время измерения абсолютного углового отклонения оптической поверхности, образующей прямой угол, а также измерений призм типа „усечённых углов” с однозначным определением угловых отклонений активной части отдельных секторов исследуемой призмы.