

Angle characteristic of curved holographic optical element

E. JAGOSZEWSKI

Institute of Physics, Technical University of Wrocław, Wybrzeże Wyspiańskiego 27, 50–370 Wrocław, Poland

A method of calculating the angle eikonal for curved holographic optical element is presented. As an example, a Fourier transform holographic lens is described, where wave fronts of the diffracted waves are constructed from the elementary holographic optical elements. The approach to the design of holographic lenses can be compared with that of the thin glass lens as its index of refraction tends to infinity. From this angle characteristic one can find the Seidel coefficients of the third order aberrations.

1. Introduction

The application of holograms as optical elements has been proposed by several authors, since their imaging properties are analogous to the lens imaging properties in conventional systems. Therefore, the holograms of a point source that may be considered as diffractive optical elements are known as holographic lenses. The latter are usually compared with thin glass lenses, their index of refraction being infinite. In recent years, there have appeared a number of papers [1]–[10] related to holographic optical elements (HOEs) imaging properties which proved to be useful for different applications. FIENUP and LEONARD [1] discuss the requirements and the performance of holographic lenses for matched filter optical processor, and have shown that the aberrations can be corrected in terms of the arbitrary desired aspheric wave fronts. The aberrations were analysed by using a holographic ray-tracing programme. Further, a method for analytical determination of the holographic element phase function is developed [2]–[4], and applied to the design of a Fourier transform holographic lens. Usually, the holographic optical element was recorded with the aid of a computer generated hologram (CGH) and was based on an analytic solution involving optimization by minimizing the output wave front deviations. In this paper, we present a simple design technique of a Fourier transform holographic lens having spherical wave fronts, recorded on a spherical substrate. As we know, a Fresnel zone plate can be considered as a special case of the holographic optical element. But zone plates are usually prepared on flat surfaces and have recently been investigated by many researchers [11]–[14]. In geometrical optics, the eikonal theory is a powerful method for the analysis of optical systems [15], therefore in this paper the angle characteristic of curved holographic optical element is given. In the determination

of holographic element, the grating equation is used instead of the law of refraction in the conventional glass lenses systems.

2. Spherical holographic lens for Fourier transform

A Fourier transform holographic lens is an optical element which converts each input plane wave having spatial frequencies ξ , η into an unaberrated image point at the coordinates

$$x_f = \lambda f \xi, \quad y_f = \lambda f \eta$$

that are determined in the back focal plane of the holographic lens (Fig. 1). λ is the wavelength of the illuminating light wave, and f is the focal length of the lens. We see that the coordinates x_f , y_f are proportional to the spatial frequencies ξ , η , respectively. In such a lens, any plane wave entering the lens from the left hand side should form a corresponding image point in the back focal plane, and likewise plane waves emerging from the right hand side of the lens should form the respective image points in the front focal plane. As it is well known, amplitude distribution in the back focal plane of an aberrationless holographic lens is the Fourier transform of the amplitude distribution $t(x_0, y_0)$ in the front focal plane. For example, the Fourier transform of a spatially varying object amplitude transmittance gives the spatial frequency content in the object. In other words, if the 1-D object transparency

$$t(x_0) = A \cos\left(2\pi \frac{x_0}{d}\right), \quad (1)$$

which is said to possess a spatial frequency $\omega/2\pi = 1/d$ is inserted in the front focal plane of this lens, then it produces two bright spots at $\omega/2\pi = \pm 1/d$ in the back focal plane of the lens. Obviously, the Fourier transform of a cosine function (1) is a sum of two delta functions, therefore two spots are produced in the Fourier plane at the points $x_f = \pm \lambda f/d$. This fact reminds that a lens recorded by a single spherical converging wave and a single collimated wave will form only diffraction limited image point (called further unaberrated image point) in the Fourier plane for the single spatial frequency corresponding to that of the collimated recording wave. For the other spatial frequencies the points are aberrated and improperly located.

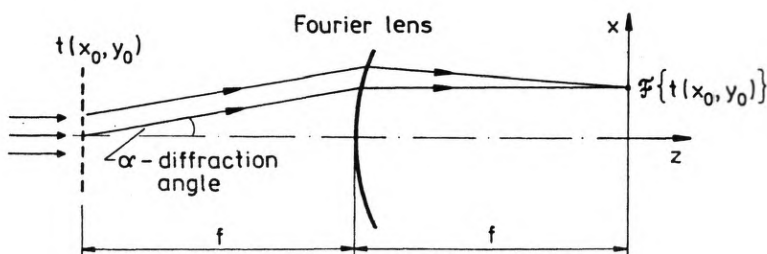

Fig. 1. Ray tracing in the curved Fourier transform holographic lens: f – focal length of the lens, $t(x_0, y_0)$ – object amplitude transmittance

As we see, a simple holographic optical element of a point source does not satisfy the requirements for Fourier transform lens which has to cover a rather extended band of spatial frequencies. Therefore, for some finite set of spatial frequencies, a more complex holographic element should be considered, since in holographic optics the aberrations are not reduced by the use of well designed multiple-element lenses as it happens in conventional optics. Usually, the solutions for holographic lens design are restricted to single holographic element on a flat substrate. Here, we take into considerations a simple holographic element recorded on a spherical substrate, as shown in Fig. 2.

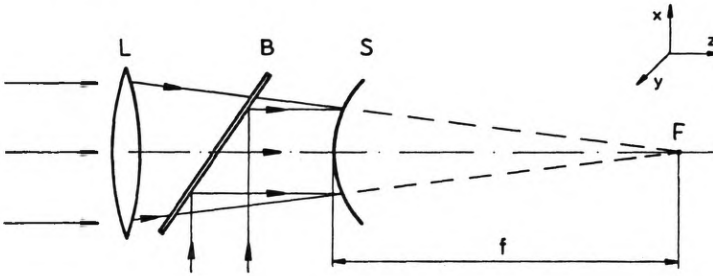

Fig. 2. Set-up for recording of an axial spherical HOE: L – lens free from spherical aberration, B – beam splitter, S – spherical substrate of holographic lens

A holographic lens is a diffractive optical element defined by its phase transfer function

$$\Phi_H(x, y) = \Phi_O(x, y) - \Phi_R(x, y) \tag{2}$$

where $\Phi_O(x, y)$ and $\Phi_R(x, y)$ are the respective phase functions of the object point source and the reference wave fronts used to construct it. If such a holographic optical element is illuminated by a wave front with the phase $\Phi_{in}(x, y) \equiv \Phi_R(x, y)$, then the phase of the output wave front is $\Phi_{out}(x, y) = \Phi_O(x, y)$. The set of input wave fronts which illuminate a holographic lens is usually described by the phase $\Phi_{in}(x, y; \alpha)$. Each value of α denotes here the diffraction angle characterizing the input plane wave front spatial frequency. If $\Phi_{out}(x, y; \alpha)$ is the phase for the perfect imaging set of output wave fronts [4], then the desired holographic element phase transfer function is

$$\Phi_H(x, y; \alpha) = \Phi_{out}(x, y; \alpha) - \Phi_{in}(x, y; \alpha). \tag{3}$$

Such a lens transforms perfectly the phase function $\Phi_{in}(x, y; \alpha)$ into $\Phi_{out}(x, y; \alpha)$ for all values of the diffraction angle α . In general, $\Phi_H(x, y; \alpha)$ varies with α , therefore the holographic optical element defined by phase function of Eq. (2) performs ideally only for one value of α . For other values of α , there exists a difference between the two phase functions

$$\Phi_H(x, y; \alpha) - \Phi_H(x, y) = \frac{2\pi}{\lambda} W(x, y) \tag{4}$$

defining the wave front deviation from the Gaussian sphere. The problem is to make this difference as small as possible for all values of the diffraction angle α .

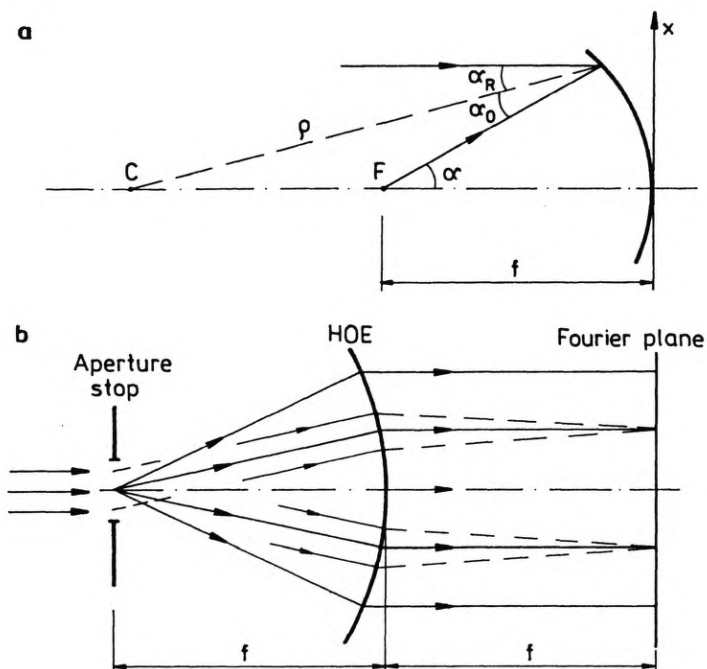

Fig. 3. Recording geometry for spherical holographic lens (a). Ray tracing of principle rays of the diffracted plane wave fronts at the aperture stop (b)

Let us consider the geometry of ray tracing through a holographic lens recorded as shown in Fig. 3a. According to this recording configuration, two unaberrated wave fronts in the image space are possible: the first spherical wave front is transformed from plane wave front, and the second plane wave front that is converted from the spherical one. If the centre of entrance pupil coincides with the point source used for recording this lens, the principle rays of all the diffracted plane wave fronts at the input axial symmetrical transparency are aberrationless after passing through the holographic lens (Fig. 3b). Such a readout geometry can be very useful in measurements of spatial frequencies of an angular spectrum of plane waves, since the images should be located in correct position of the output focal plane of the lens.

In the case of spherical substrate on which the holographic optical element is recorded, the phase transfer of such a lens depends in addition upon the surface function

$$F(x, y, z) = z - (x^2 + y^2)/2R - (x^2 + y^2)^2/8R^3 \quad (5)$$

and is given by

$$\Phi_H(x, y) = 2\pi/\lambda [(x^2 + y^2)/2(f-z) - (x^2 + y^2)^2/8(f-z)^3] \quad (6)$$

where R is the curvature radius of the spherical substrate, and f is the distance between the surface vertex and the point source emitting a spherical recording wave front (*i.e.*, focal length of the lens).

3. Angle eikonal

According to the definition of angle eikonal [15], each optical length $[P_C P_I]$ of the ray between the feet P_C and P_I drawn perpendicularly from the points O_C and O_I (Fig. 4) to the incident and diffracted rays, respectively, is

$$T = [P_C P] + [P P_I].$$

If the coordinates of intersection point P of the incident ray with the holographic element surface are (x, y, z) , then the angle eikonal is given by

$$T = [xp_C + yq_C + (z - z_C)m_C] - [xp_I + yq_I + (z - z_I)m_I], \quad (7)$$

where (p_C, q_C, m_C) and (p_I, q_I, m_I) are direction cosines of the incident and diffracted rays, respectively. In general, the interference fringes of the holographic element are curved and variably spaced. The grating equation [16] for the first diffraction order ray tracing is described by

$$\vec{n} \times (\vec{r}_I - \vec{r}_C) = \frac{\lambda}{\lambda_0} \vec{n} \times (\vec{r}_O - \vec{r}_R) \quad (8)$$

where \vec{n} is the unit vector normal at point P of the HOE, and $\vec{r}_R, \vec{r}_O, \vec{r}_C, \vec{r}_I$ are the unit vectors along the reference, object, reconstruction and image rays at the intersection point P of the hologram surface. The construction and readout wavelengths are denoted by λ_0 and λ , respectively. Using the above equation, the coordinates of the intersection point P in expression (7) may be eliminated, and the direction cosines of the diffracted ray are represented by equations:

$$p_I = p_C + \frac{\lambda}{\lambda_0} (p_O - p_R),$$

$$q_I = q_C + \frac{\lambda}{\lambda_0} (q_O - q_R), \quad (9)$$

$$m_I = 1 - (p_I^2 + q_I^2)/2 - (p_I^2 + q_I^2)^2/8,$$

whereas the direction cosines of the incident ray are connected by the equation

$$m_C = \sqrt{1 - (p_C^2 + q_C^2)} \simeq 1 - (p_C^2 + q_C^2)/2 - (p_C^2 + q_C^2)^2/8 \dots$$

To find the normal at the point $P(x, y, z)$ of the hologram surface, the partial derivatives of the surface normal are given by

$$\frac{\partial F}{\partial x} = -\left[\frac{x}{R} + \frac{x(x^2 + y^2)}{2R^3} + \dots \right],$$

$$\frac{\partial F}{\partial y} = -\left[\frac{y}{R} + \frac{y(x^2 + y^2)}{2R^3} + \dots \right],$$

$$\frac{\partial F}{\partial z} = 1.$$

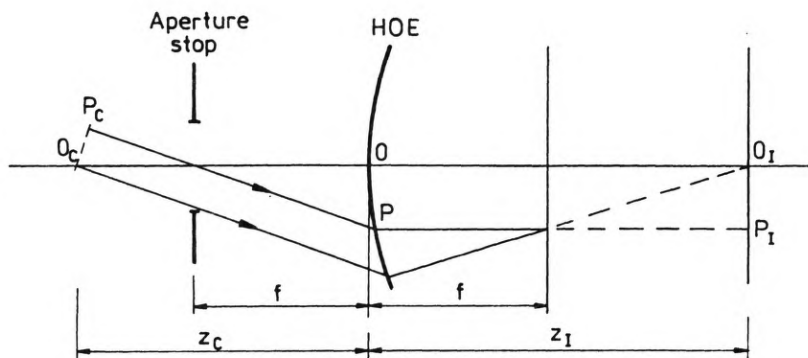

Fig. 4. Illustration of angle eikonal $T = [P_C P_I]$ for a curved holographic optical element

According to the general diffraction grating approach by GOTO, KATO and TOGAWA [17], we assume that the grating is composed of many local elementary gratings and we introduce unit vectors: \vec{A} , \vec{G} and \vec{n} to each point of the grating in such a way that \vec{A} is perpendicular to the interference fringes, \vec{G} — parallel to the fringes and \vec{n} — normal to the grating surface, respectively. These vectors are connected by the equations:

$$\vec{G} = \frac{\vec{n} \times \nabla \Phi_H(y, y, z)}{|\vec{n} \times \nabla \Phi_H(x, y, z)|}, \quad \vec{A} = \vec{G} \times \vec{n}. \quad (10)$$

Here, the spatial frequency of an elementary grating is given by

$$\omega = |\vec{n} \times \nabla \Phi_H(x, y, z)|$$

where gradient of the phase transfer function recorded on the curved surface is represented by $\nabla \Phi_H(x, y, z)$. Denote by r_A , r_G and r_n the components of the unit ray vector \vec{r}_C with respect to \vec{A} , \vec{G} , and \vec{n} . Then

$$\vec{r}_C = r_A \vec{A} + r_G \vec{G} + r_n \vec{n},$$

and the unit vector \vec{r}_I of diffracted wave front by applying the grating equation to elementary grating is as follows:

$$\vec{r}_I = r'_A \vec{A} + r'_G \vec{G} + r'_n \vec{n}, \quad (11)$$

where

$$r'_A - r_A = \omega/k, \quad r'_G - r_G = 0, \quad r'_n = \sqrt{1 - r_A'^2 - r_G'^2},$$

$k = 2\pi/\lambda$ is the wave number of light used. By solving the grating equations:

$$(\vec{r}_I - \vec{r}_C)\vec{A} = \omega/k, \quad (\vec{r}_I - \vec{r}_C)\vec{G} = 0,$$

we obtain

$$x = (p_I - p_C) \frac{\omega^2}{k^2} \frac{f}{(p_I - p_C)^2 + (q_I - q_C)^2} + \Delta x,$$

$$y = (q_I - q_C) \frac{\omega^2}{k^2} \frac{f}{(p_I - p_C)^2 + (q_I - q_C)^2} + \Delta y$$

where Δx and Δy being quantities of the third and higher orders in $p, q, x/R, y/R$ may be neglected. To find the expansion of the angle eikonal up to the fourth order terms it is not necessary to evaluate Δx and Δy . Using the notation:

$$u^2 = p_C^2 + q_C^2, \quad v^2 = p_I^2 + q_I^2, \quad w^2 = p_C p_I + q_C q_I,$$

we obtain the expression of the angle eikonal in the form

$$T = z_I - z_C + z_C u^2/2 - z_I v^2/2 + z_C u^4/8 - z_I v^4/8 - \omega^2 f/k^2 \\ + \frac{\omega^4}{k^4} \frac{f^2(v^2 - u^2)}{4R(v^2 + u^2 - 2w^2)} \left(1 + \frac{v^2 + u^2}{4}\right) \left[1 + \frac{\omega^4}{k^4} \frac{f^2}{2R^2(v^2 + u^2 - 2w^2)}\right].$$

4. Conclusion

The angle eikonal for curved holographic optical element has been derived. The consideration is based on the theory of elementary grating developed by Goto, Kato and Togawa. From these results, the Seidel coefficients of the third order aberrations can be determined.

References

- [1] FIENUP J. R., LEONARD C. D., *Appl. Opt.* **18** (1979), 631.
- [2] FAIRCHILD R. C., FIENUP J. R., *Opt. Eng.* **21** (1982), 133.
- [3] WINICK K. A., FIENUP J. R., *J. Opt. Soc. Am.* **73** (1982), 208.
- [4] CEDERQUIST J. N., FIENUP J. R., *J. Opt. Soc. Am. A* **4** (1987), 699.
- [5] KEDMI J., FRIESEM A. A., *Appl. Opt.* **23** (1984), 4015.
- [6] KEDMI J., FRIESEM A. A., *J. Opt. Soc. Am. A* **3** (1986), 2011.
- [7] AMITAI Y., FRIESEM A. A., *J. Opt. Soc. Am. A* **5** (1988), 702.
- [8] ASSENHEIMER M., AMITAI Y., FRIESEM A. A., *Appl. Opt.* **27** (1988), 4747.
- [9] AMITAI Y., FRIESEM A. A., *Opt. Lett.* **13** (1988), 883.
- [10] HASMAN E., FRIESEM A. A., *J. Opt. Soc. Am. A* **6** (1989), 62.
- [11] MYERS O. E., Jr., *Am. J. Phys.* **19** (1951), 359.
- [12] WALDMAN G. S., *J. Opt. Soc. Am.* **56** (1966), 215.
- [13] LOHMANN A. W., PARIS D. P., *Appl. Opt.* **6** (1967), 1567.
- [14] YOUNG M., *J. Opt. Soc. Am.* **62** (1972), 972.

- [15] BORN M., WOLF E., *Principles of Optics*, The Macmillan Co., New York 1964.
- [16] WELFORD W. T., *Opt. Commun.* 14 (1975), 322.
- [17] GOTO K., KATO Y., TOGAWA K., *Opt. Acta* 26 (1979), 841.

Received February 20, 1995