

N. N. PISANKO*

SEWAGE TREATMENT IN MINING, METALLURGICAL AND OIL-CHEMICAL INDUSTRIES

The complex of problems concerning environment protection, being the subject of investigations conducted in the Institute of "Ukrvodkanalproekt", has been presented. It includes, among others, mechanical processing of industrial wastewater, utilization of sludges, and the recovery of water and its reuse in industry. Some examples of solutions obtained at the Institute are given, i.e.: vertical thickener of polyacrylamide solutions, utilization of secondary horizontal sedimentation tanks equipped with chambers for magnetic flocculation and separation of slags from ashes. A diagram of flows at the pulp thickening is also given.

The paper is devoted to the fundamental trends of the work of the "Ukrvodokanalproekt" Institute, concerning the efficient use of water resources and environment protection.

Mechanical sewage treatment of water, its reuse during production processes, as well as the utilization of the sludge of metallurgical enterprises, are considered.

Flow diagram of pulp thickening, the designs of the vertical thickener for preparation of polyacrylamide solution, as well as the use of secondary horizontal settling tanks with the chamber of magnetic flocculation for the cinder extraction from sewage, are given as examples.

The "Ukrvodokanalproekt" Institute is engaged in designs of water supply, sewer systems and hydrotechnical structures of industrial enterprises, a great attention being given to the most acute problem, i.e. the efficient use of water resources and environment protection.

The largest part of the work has been carried out for mining, metallurgical and chemical enterprises.

These objects are characterized by a high water flow, the use of the recycle water supply systems and the reuse of treated sewage.

* State Project Institute "Ukrvodokanalproekt", Kiev, USSR.

The fundamental trends of research works conducted at the Institute on the development of modern water supply systems and sewage are the following:

- a) introduction of waterless technological processes,
- b) reduction of water consumption,
- c) design of closed water supply cycles with treated sewage reuse,
- d) introduction of local systems of sewage treatment during which the valuable components are extracted,
- e) thorough sewage treatment by means of desalination, ozonation and adsorption,
- f) applications of new chemicals in treatment of sewage and natural waters and the reuse of waters as chemicals.
- g) treatment of sewage sludge, its utilization and disposal.

A major portion of the work is connected with the experimental design and realization of new structures and flow diagrams of water and sewage treatment.

This work is being carried out in close contact with the research institutes, the plans of which for the nearest years and perspective are made without our participation.

The standard projects of sewage and water supply facilities and plants for the serial use in various branches of industry are developed.

Particular attention is focussed on the development of computer programmes and their application in choice of technologically and economically optimal variants of individual structures and technological processes.

All the designs accepted by the Institute are subject to technical and economical estimation.

The experience in operation of structures and systems, realized in the latest years according to new technical concepts, confirms that their efficiency and economy are higher if compared to the traditional ones. As examples, we may show some technical measures, developed at our Institute and realized.

In the mining industry, ferriferous concentrate is obtained from the natural ore by using the wet-separation method according to which a large amount of sewage is in the form of a pulp-rock, strongly diluted with water.

In the pulp, solid phase to water weight ratio ranges from 1:15 to 1:25.

The pulp is supplied for settling to the tailing storage, whereupon the clarified water goes back to the works.

Such a flow diagram of the pulp supply to the tailing storage, which, as a rule, is located at a considerable distance from the ore concentration enterprises, requires a high electric energy consumption, the construction of large pulp-pumping stations with heavy equipment, as well as long pipelines and water mains.

According to the flow diagram developed at our Institute for sewage clarification after ore concentration, the pulp, before being fed to the tailing storage, is thickened until the solid phase to water ratio increases from 1:3 to 1:1.

The clarified water goes right away to the works, and the thickened pulp is transported to the tailing storage.

In this case, with the reduction of the energy consumption, the diameters of pipelines,

the pumping and energetic equipment, as well as the expenses for the whole system operation are reduced.

The flow diagram of pulp thickening is presented in fig. 1.

The hydromixture from the ore concentration plant is supplied by a trough to the distribution chamber 2. The flocculant solution (polyacrylamide) promoting coagulation and settling of the fine-dispersed suspension flows from the building for chemicals 3 through the pipeline 10 and arrives to the same chamber 2. From the distribution chamber 2 the hydromixture goes to the thickeners 4, and in the case of emergency regime it passes by the pipe 5 to the special tank.

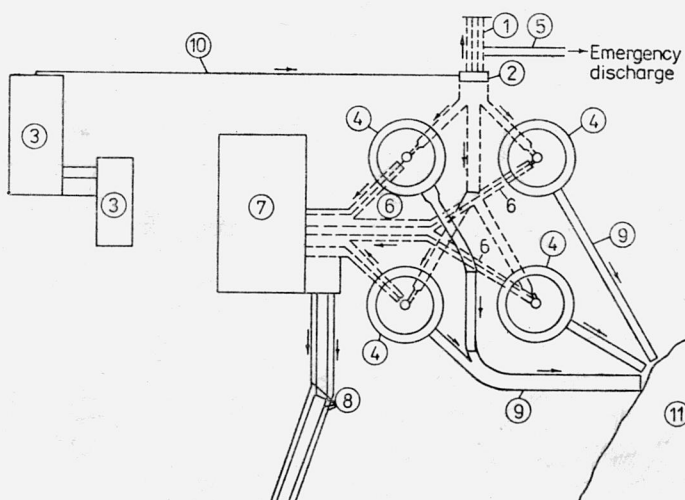

Fig. 1. Flow diagram of pulp thickening

1 — trough supplying hydromixture, 2 — distribution chamber, 3 — building for chemicals, 4 — thickener, 5 — trough of emergency discharge, 6 — piping of thickened pulp, 7 — pulp pumping station, 8 — pressure pulp pipings, 9 — troughs of clarified water, 10 — chemicals pipings, 11 — pond of recycled water supply

Rys. 1. Schemat blokowy zagęszczania pulpy

1 — rynna dostarczająca uwodnioną mieszaninę, 2 — komora rozdzielna, 3 — budynek na chemikalia, 4 — zagęszczacz, 5 — rynna przepływu awaryjnego, 6 — rurociąg zagęszczonej pulpy, 7 — pompownia pulpy, 8 — ciśnieniowe rurociągi pulpy, 9 — rynny sklarowanej wody, 10 — rurociągi chemikaliów, 11 — staw dostarczający wodę obiegową

The thickened hydromixture (sludge) enters the receiving chamber of the pulp-pump-ing station 7 through the pipelines 6, laid in tunnels, and then is pumped to the tailing storage.

The clarified water from thickeners 4 flows along the pipe 9 to the pond of recycle water supply 11, from where it is delivered to the ore concentration plant. In order that residual polyacrylamide be disintegrated, the clarified water must remain in the pond for less than 24 h.

A research work was conducted at one of the ore concentration enterprises where the pulp consumption was not higher than $20 \text{ m}^3/\text{s}$; the new type of a vertical thickener with the shelf-type medium was tested under the industrial conditions (fig. 2).

If the operation of the radial thickener is based on gravitational settling of the suspension over the whole depth of the settling tank, the clarification of pulp in the vertical thickener with the medium of shelf type takes place in a thin water layer.

Basic design of the vertical thickener lies in the special device which supplies the initial pulp and distributes it uniformly over the whole thickener's area in the water clarification process, uniform water collection from the whole area of the thickener, and the removal of thickened pulp.

The initial pulp is delivered by the pipeline 1 to the central part 2 of the thickener (fig. 2).

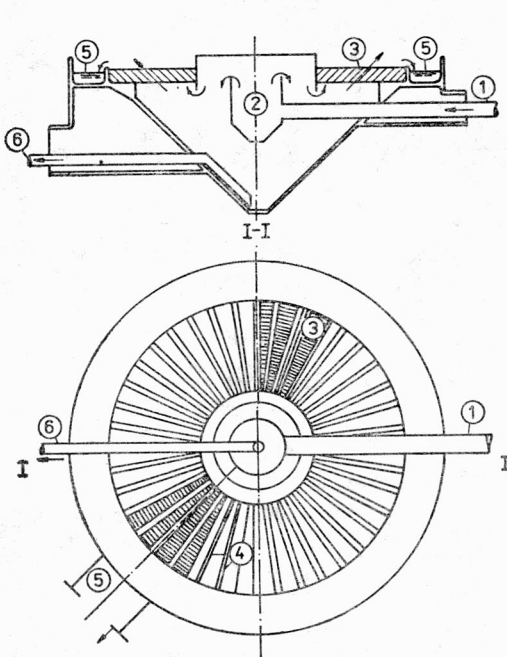

Fig. 2. Vertical thickener

1 — supplying piping, 2 — central part, 3 — thin-layer shelf-type medium, 4 — radial collecting troughs, 5 — trough diverting clarified water, 6 — piping of thickened pulp

Rvs. 2. Zagęszczacz pionowy

1 — rurociąg doprowadzający, 2 — część środkowa, 3 — cienkowarstwowe (środowisko półkowe), 4 — radialne rynny zbierające, 5 — rynna zmieniająca kierunek sklarowanej wody, 6 — rurociąg zagęszczonej pulpy

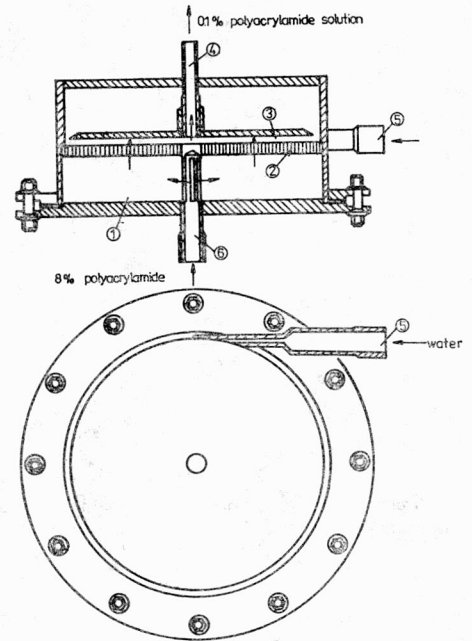

Fig. 3. Vortex disperser

1 — supplying chamber, 2 — perforated partition, 3 — dispersing chamber, 4 — piece of pipe diverting polyacrylamide solution, 5 — tangential piece of pipe of water delivery, 6 — piece of pipe supplying 8% polyacrylamide solution

Rys. 3. Wirowe urządzenie dyspersyjne

1 — komora zasilająca, 2 — perforowana przegroda, 3 — komora dyspersji, 4 — część rury zmieniającej kierunek roztworu poliakrylamidu, 5 — sztywna część rury dostarczającej wodę, 6 — część rury dostarczającej 8% roztwór poliakrylamidu

In order to intensify the pulp clarification process, the thickener is equipped with a thin-layer divider and shelf-type medium in the cells of which the laminar regime of the flow stream is maintained.

The thin-layer divider makes the solid particles to settle in laminar stream of small depth, thus increasing the thickener capacity and improving the clarified water quality. The hydraulic load of pulp on the thickener mares up to 40–45 m³/m²/h; the content of suspended solids in this load at the outlet does not exceed 500 mg/dm³, the initial concentration is 30,000 mg/dm³. In this case, the poliacrylamide dose enlarged by 100% equals 1 mg/dm³.

The collection of clarified water is realized by a system of radial troughs 4, designed so that it assures a uniform flow distribution and the thickener operation at the same specific load over the whole area.

The clarified water is carried away by trough 5, and the thickened pulp is under the hydrostatic pressure removed by the pipeline 6.

Together with the highly efficient thickeners, installed in the building for chemicals, the vortex disperser for preparing the polyacrylamide solution and high-capacity exchange packages are used.

The vortex disperser, being the central chain in the unit of polyacrylamide solution, comprises two technological operations:

- 1) dispersion of polyacrylamide by a turbulent fluid flow and the formation of the polydispersed suspension of a polymere in the solvent,
- 2) obtaining the homogenous solution (without solvent water heating) of 0.05–0.1% concentration.

The vortex disperser operates in a continuous technological cycle, it is easily adjustable and its exploitation is reliable. The design of apparatus is presented in fig. 3.

The high-viscous matter, passing through the piece of pipe 2 to the feeding chamber 1, goes through the perforated partition 2 to the dispersing chamber 3, where it is pulverized by the vortex flow, then supplied under the pressure to the chamber 3 through the tangential piece of pipe 5. In chamber 3, the polymer dispersion in the liquid takes place. Thereupon there occurs the flocculant dissolution in the vortex flow. The ready polyacrylamide solution is carried away through the piece of pipe 4. The proposed disperser design ensures a uniform supply of polyacrylamide over the whole area of the partition, which practically cannot be obtained in the known constructions with vertical arrangement of perforated surfaces.

The new flow diagram of processing the large quantities of polyacrylamide in vortex disperser reduces considerably the capital investments for the construction of the building for chemicals and the manual labour, makes the operation simple, and excludes the use of hot water for a flocculant dissolution.

An automatic control of the pulp thickening process and supply of chemicals are carried out by the control of polyacrylamide solution concentration according to the turbidity of the clarified water. Such a control system makes it possible to save up to 10% of polyacrylamide and to improve the process of pulp clarification and thickening.

One of the new trends in pulp thickening is electromagnetic flocculation of the pulp prior to its clarification in thickeners. Preliminary data demonstrate the high efficiency of this method, which permits a sharp reduction or even exclusion of polyacrylamide from the technology.

Introduction of new decisions concerning pulp thickening at one of the objects made it possible to reduce capital investments by \$ 4,760,000 and operation expenditures by \$ 2,560,000.

According to our project, facilities for cinder extraction from sewage of the rolling mill with the use of magnetic flocculation are being realized in one metallurgical plant (fig. 4).

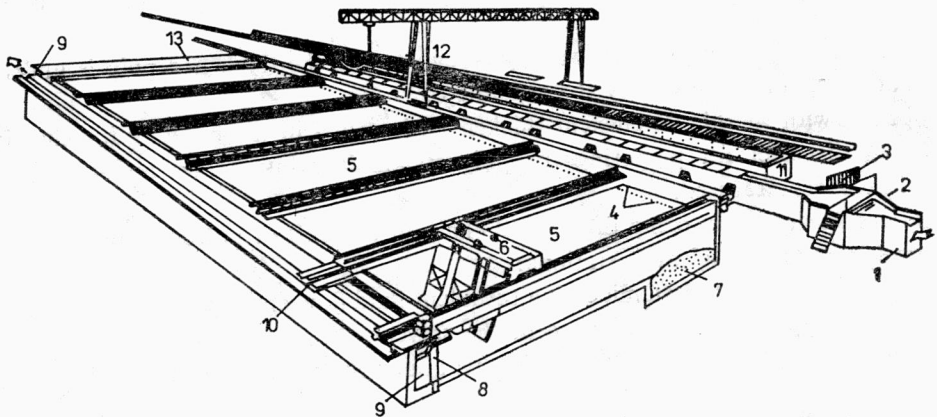

Fig. 4. Secondary horizontal settlers with magnetic flocculation

1 - delivering trough, 2 - screen, 3 - magnetic flocculator, 4 - water distribution pipes, 5 - secondary horizontal settlers, 6 - scraper truck, 7 - cinder sump, 8 - oil diverting trough, 9 - clarified water trough, 10 - truck, 11 - sludge dewatering bunker, 12 - gantry crane, 13 - oil pumping station

Rys. 4. Horyzontalne osadniki wtórne z magnetyczną flokulacją

1 - rynna zasilająca, 2 - sito, 3 - magnetyczny flokulator, 4 - rury rozprowadzające wodę, 5 - horyzontalne osadnik wtórne, 6 - zgarniacz, 7 - studzienka popiołu, 8 - rynna zmieniająca kierunek oleju, 9 - rynna sklarowanej wody, 10 - wózek, 11 - zbiornik odwadniania osadu, 12 - suwnica bramowa, 13 - stacja pompowania oleju

Magnetic flocculator consists of cassetts with the magnetized ferritobarium washers.

In the flow diagram, the magnetic flocculator 3 is installed prior to the secondary settling tanks 5 in supplying trough 1.

When passing through the flocculator, sewage is magnetized and its cinder floccules are enlarged, then delivered from the supplying trough to the secondary settling tanks 5 through distribution system 4.

Secondary horizontal settling tanks are equipped with the scraper mechanism 6 for rabling the cinder to the sump 7 and collecting the oil floating to the surface into the trough 8.

The clarified sewer liquid from the secondary settling tanks is returned by trough 9 for the reuse.

Cinder from the secondary settling tanks arrives at the sump 7, from where it is delivered by the gantry crane, supplied with the grab, to the bunker 11 for dewatering. Dewatered cinder is sent by the railway transport to the mill and after clodding and briquetting it is utilized.

Oil, collected from the water surface of the secondary settling tanks, is returned to the oil pumping station 13 by trough 8, and after the preclarification it goes back to the rolling shop.

Secondary horizontal settling tanks are composed of 11×33 m sections. The load per section of the settling tank is $650 \text{ m}^3/\text{h}$.

Application of the large-sized secondary settling tanks with the dispersed water inlet and preliminary magnetic flocculation allowed us to shorten the duration of the settling and to increase the load for settling tanks to 30%, keeping the clarification effect to $50\text{--}100 \text{ mg}/\text{dm}^3$ of suspended solids, with the initial cinder content of $400\text{--}500 \text{ mg}/\text{dm}^3$.

The diagram developed (fig. 5) for sewage treatment from one of the enterprises of

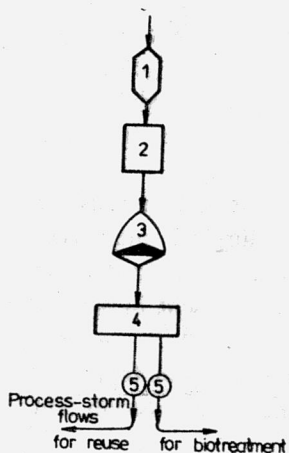

Fig. 5. Diagram of processing of oil-containing sewage

1 - grit chamber, 2 - oil separator, 3 - ponds, 4 - tank and pumping station of filtered water, 5 - filters

Rys. 5. Schemat obróbki ścieków zawierających olej

1 - piaskownik, 2 - separator oleju, 3 - stawy, 4 - filtry, 5 - zbiornik i pompownia filtrowanej wody

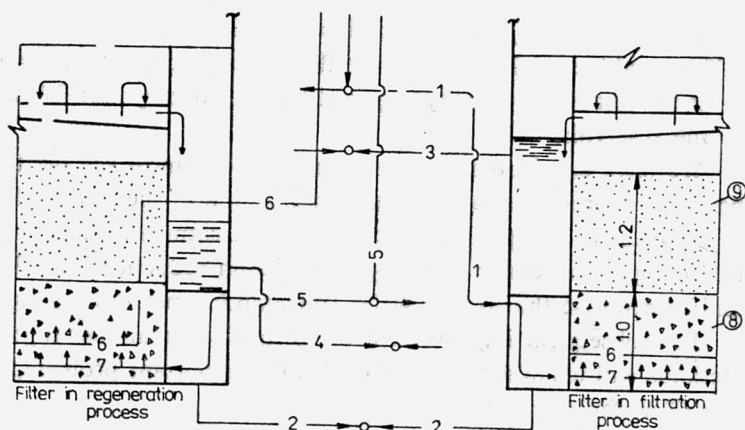

Fig. 6. Filters for post-treatment of oil-containing sewage

1 - sewage supply to filters, 2 - emptying of filters, 3 - filtrate disposal, 4 - wash water disposal, 5 - wash water supply, 6 - air piping, 7 - drainage, 8 - gravel, 9 - sand

Rys. 6. Filtry do końcowej obróbki ścieków olejowych

1 - doprowadzenie ścieków do filtrów, 2 - opróżnianie filtrów, 3 - odprowadzenie filtratu, 4 - odprowadzenie wody do płukania, 5 - doprowadzenie wody do płukania, 6 - rurociąg powietrza, 7 - drenaż, 8 - żwir, 9 - piasek

oil-chemical industry provides the pre-separation of oil products and oil mud with the initial concentration of $2-5 \text{ g/dm}^3$ and settling on oil separators and settling ponds, followed by more thorough treatment on quartz filters. Filters are shown in fig. 6.

Filter media consists of a sand layer of $2-0.75 \text{ mm}$ coarseness, 1.2 m height and some layers of gravel of $2-32 \text{ mm}$ coarseness and 1.0 m total height.

Filtration proceeds upward from the bottom at the rate of 5.0 m/h . Due to the large capacity of the filter, the filter-cycle duration takes 2 days. The oil products contents in sewage after filtration decrease from $70-80$ to $25-30 \text{ mg/dm}^3$. Exploitation demonstrated the efficiency of filter operation.

Regeneration of filters is realized by treated sewage in two stages, applying cold and hot water with air blowing.

Due to the complicated conditions of regeneration, we are carrying out attempts at introducing the more capacious and easily regenerated media.

In order to improve the treatment efficiency and to have the possibilities for the following use, the sewage coming from the works is subdivided into separate flows:

1. Process and storm flows (the main bulk of sewage), polluted by oil products only, which after the treatment go back to be applied in the system of the process water line.
2. Salt-containing and other flows, polluted with oil products and salts (chlorides, sulfates, sulfides and others). These flows, being subject to the additional biological treatment to achieve the quality required by the sanitary and fish industry standards, return to the reservoir.

We have considered the questions of mechanical sewage treatment and its reuse in production processes, as well as the utilization of the sludge of metallurgical enterprises.

At present, along with works on water treatment, our attempts are made to develop technological processes allowing a maximum reduction of pollutants present in sewage and to decrease the specific water consumption per unit of production.

The subsequent improvement of mechanical treatment together with other treatment methods will make it possible to solve the important problem, namely the most efficient use of water resources.

OCZYSZCZANIE ŚCIEKÓW W PRZEMYSŁE WYDOBYWCZYM, METALURGICZNYM I CHEMICZNYM

Przedstawiono zakres problematyki badawczej z dziedziny ochrony środowiska podejmowanej w Instytucie „Ukrvodokanalproekt” w Kijowie. Obejmuje on, między innymi, mechaniczną obróbkę ścieków przemysłowych i utylizację osadów oraz odnowę wody i jej ponowne wykorzystanie w przemyśle. Podano przykłady rozwiązań opracowanych w Instytucie: pionowy zagęszczacz roztworów poliakryloamidu, wykorzystanie wtórnych poziomych zbiorników osadowych wyposażonych w komorę magnetycznej flokulacji i oddzielanie żużli i popiołów. Przedstawiono również diagram przepływów przy zagęszczaniu pulp.

DIE ABWASSERREINIGUNG IN DER FÖRDER-, IN DER METALLURGISCHEN UND IN DER CHEMISCHEN INDUSTRIE

Vorgestellt wird die Untersuchungsproblematik auf dem Gebiet des Umweltschutzes, die im Institut „Ukrvodokanalprojekt“ in Kiev bearbeitet wird. Sie umfasst u.a. die mechanische Reinigung von diversen Industrie-Abwässern, die Schlammbehandlung und -verwertung, die Wasserrückgewinnung und den erneuten Einsatz dieses Wassers in Industrieanlagen. Beschrieben werden betriebseigene, technologische und technische Lösungen des Instituts: ein vertikaler Eindicker für Polyacrylamidlösungen, die Anwendung von horizontalen Nachklärbecken, die mit einer magnetischen Rührkammer zur Absonderung von Schlacke und Asche ausgerüstet sind. Wiedergegeben wird auch ein Fließdiagramm zur Eindickung von Dickstofflösungen.

ОЧИСТКА СТОЧНЫХ ВОД В ДОБЫВАЮЩЕЙ, МЕТАЛЛУРГИЧЕСКОЙ И ХИМИЧЕСКОЙ ПРОМЫШЛЕННОСТИ

Обсуждён объём исследовательской проблематики из области охраны среды, предпринимаемой в институте Укрводоканалпроект в Киеве. Он охватывает, наряду с другими, механическую обработку промышленных сточных вод и утилизацию хвостов, а также регенерацию воды и повторное её использование в промышленности. Приведены примеры решений, разработанных в Институте: вертикальный сгуститель растворов полиакрилоамида, использование вторичных горизонтальных отстойников, снабжённых магнитной камерой флокуляции и отделения. Приведена также диаграмма течений при сгущении пульпы.