

# Testing of mechanical properties of materials by means of an optical method based on light diffraction

ANDRZEJ WASILEWSKI, TOMASZ WIĘCEK

Department of Physics, Technical University of Rzeszów, ul. W. Pola 2, 35–959 Rzeszów, Poland.

ANDRZEJ K. JONSCHER, 33 Lynwood Rd, London W5 1JP, UK.

A diffractographic method was used for testing of the mechanical vibrations. Damping in a material is evaluated by observation of the vibration amplitude in time. Theoretical and experimental data for several materials are compared.

## 1. Introduction

The perfect elastic solid state exhibits a one-to-one relation between stress and deformation. Thus the vibrating energy is constant. In practice, we usually have divergence from this relation, which is due to the internal friction. When the sample is under periodic stress one can obtain deformation vs. stress relation. In plane deformation the stress dependence is visualised as a closed loop. The area inside the loop for the whole period is a measure of the dissipated energy. There are many causes of internal friction, the basic one being due to thermoelasticity. If any elastic anisotropic polycrystal is vibrating some of crystal grains are more deformed than others. The deformation indicated above is related to changes of temperature. The heat is being transferred from one crystal cell to another. This is a reason of the observed dumping. The thermoelastic damping is also in bended bar. Longitudinal fibres are pressed and they give warm while stretched fibres get cool. In a bar there is a temperature gradient which depends on the period of bending vibrations. According to the temperature gradient the heat transfer is from the one side to the other and energy dissipation takes place. The thermoelastic dumping is an example of linear dumping because transfer of heat and rate of the growth of deformation  $d\varepsilon/dt$  are proportional to the temperature gradient, consequently to stress. When plotting the curve obtained from measurements of dumping we use optical method because it is of non-contact and uninertia type.

## 2. Experimental and results

The measurement of the surface translation due to dynamic vibration is very difficult, because translation is usually very small ( $< 20 \mu\text{m}$ ). The optical measurement method is based on a diffraction of light on a slit. The slit is made by the

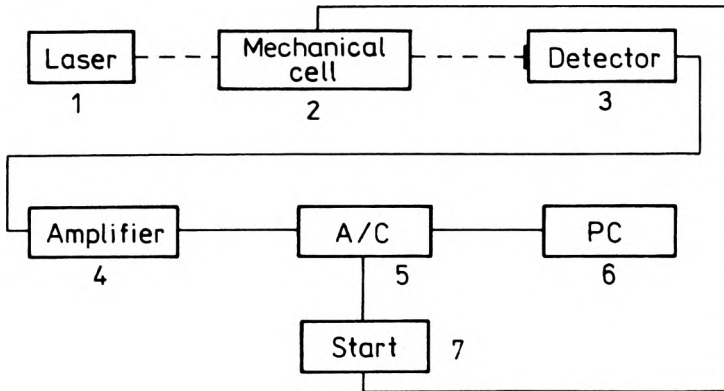

Fig. 1. Block representation of measuring system: 1 – He-Ne laser, 2 – cell for mechanical measurement, 3 – detector, 4 – amplifier, 5 – 12 bit A/C converter, 6 – computer, 7 – “start” button and delay line.

vibrating surface and reference edge. In the case of motion surface and reference edge, the diffraction pattern will change. The variation of the diffraction pattern is detected by optoelectronic sensor [1]–[3].

In this paper, we describe the measurements of small linear dimensions by an analysis of diffraction patterns (Fig. 1). One can measure separation of two objects by observation of the far-field diffraction light on a slit aperture formed between the edge and vibrating surface.

The detector consists of BPW 34 photodiode. A delay line is used for adjustment of the mechanical pulse time and to start the recording system of an optical signal. The cell used for mechanical measurements is shown in Fig. 2.

As shown in Fig. 2, metal ball (5) strike bar (1) thus existing bar oscillations. Oscillating bar changes slit (3). The width of the slit (3) recorded by means of optical system (Fig. 3). When width  $d$  of the slit is changed, the space distribution of

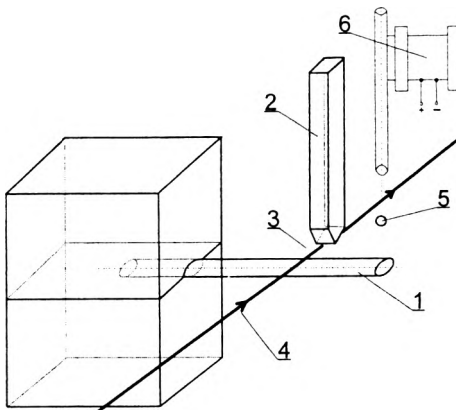

Fig. 2. Schematic view of the setup used for transformation of mechanical values into optical signal. 1 – bar-shaped material subjected to mechanical oscillations, 2 – edge for adjustment the slit, 3 – slit, 4 – laser beam, 5 – metal ball, 6 – metal ball injector.

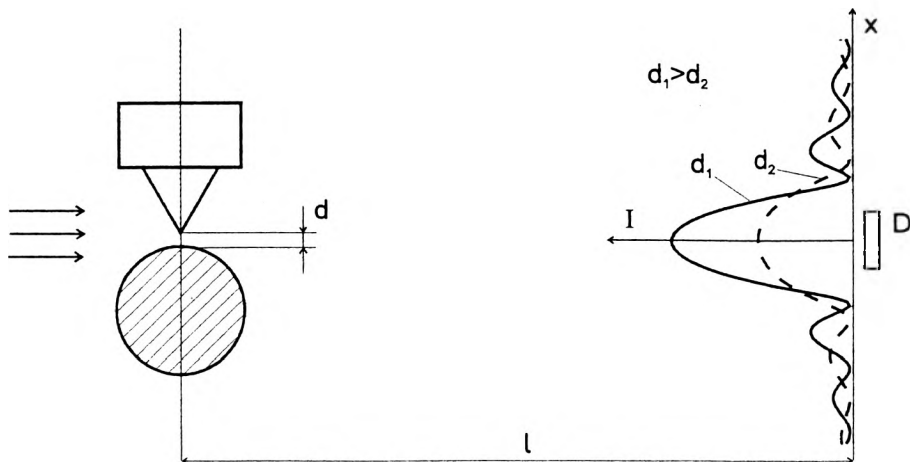

Fig. 3. Diffraction pattern of the slit.  $I$  – light intensity,  $D$  – detector,  $d$  – width of the slit.

diffraction fringes changes according to the formula

$$I(x, d) = A^2 d^2 \frac{\sin^2\left(\frac{\pi dx}{\lambda l}\right)}{\left(\frac{\pi dx}{\lambda l}\right)^2}$$

where:  $A$  – light amplitude,  $I(x, d)$  – light intensity.

Optical signal is transformed by the photodiode to electrical one, thus amplified and digitalised. In our experiment, it is possible to record up to 8000 measurement points. The records are stored in computer memory. Then damped waveform  $g(t)$  is fitted to experimental data  $Y(t)$  by means of the least squares method. An example of such fit is shown in Fig. 4.

In numerous materials (Al, glass, plastic materials – hostaform, bakelite) there is stable frequency of oscillations and the decay of amplitude is exponential. From

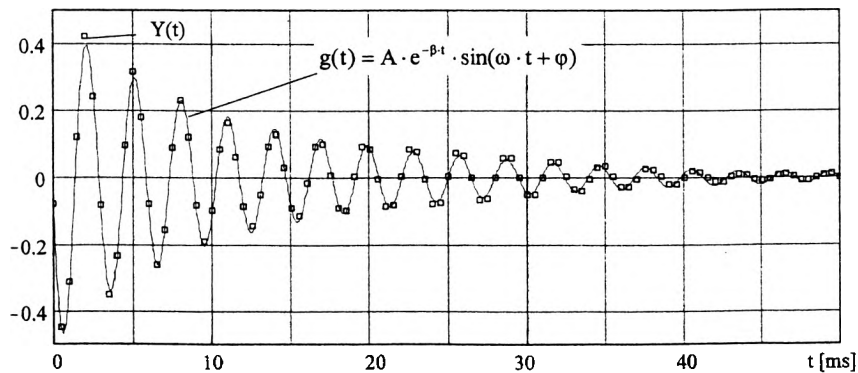

Fig. 4. Amplitude as a function of time:  $g(t)$  – theoretical values,  $Y(t)$  – experimental values.

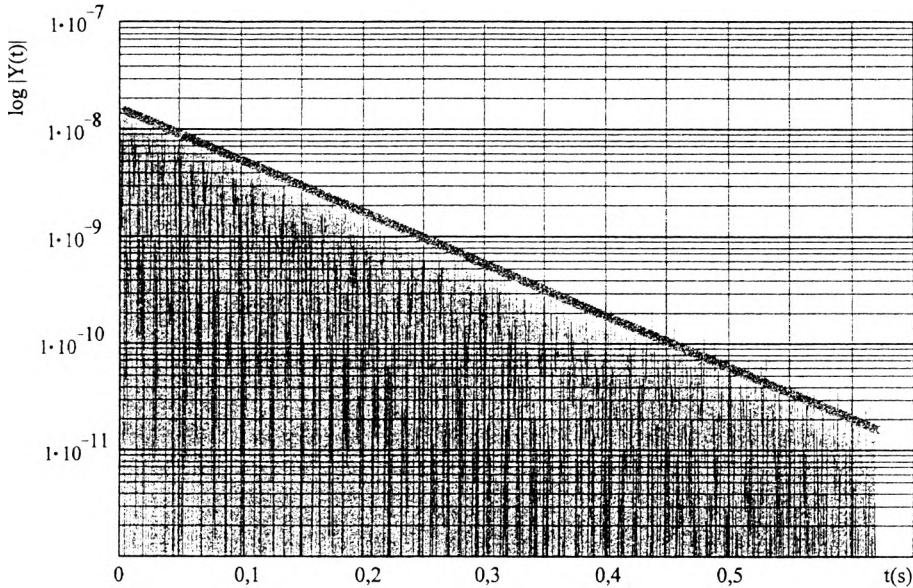

Fig. 5. Logarithmic amplitude as a function of time.

From Figure 5 it can be seen that damping of material follows an exponential function. It is attempted to use the method to investigate mechanical properties of fibers.

### 3. Conclusions

When the surface of testing materials changes position, we obtain variation of the optical signal, which shows damping of the amplitude. Several materials such as duraluminium, glass, plastic material (hostaform, bakelite) exhibit time dependence of amplitude according to exponential function.

*Acknowledgments* – The authors wish to thank Prof. A. Szymański for his helpful and stimulating remarks.

### References

- [1] WIĘCEK T., Proc. SPIE 2340 (1994), 449.
- [2] GOODMAN J., *Introduction to Fourier Optics* (in Russian), [Ed.] Mir, Moscow 1970.
- [3] PRYOR R., HAGENIERS O. L., NORTH W. P. T., Appl. Opt. 11 (1972), 308.

Received June 25, 1999