

399.

XXV Tafeln

zur

allgemeinen

Baukunde des Ingenieurs

von

Mar Becker,

Ingenieur und Professor des Wasser- und Straßenbaues an der Großherzoglichen polytechnischen Schule zu Karlsruhe.



Stuttgart,

Carl Neuen, Verlagsbuchhandlung.

1853.

XXV Tafeln

399.

zur

allgemeinen

Baukunde des Ingenieurs

von

Max Becker,

Ingenieur und Professor des Wasser- und Straßenbaues an der Großherzoglichen polytechnischen Schule
zu Karlsruhe.



Leihgabe an die
Bibliothek der
Techn. Hochschule
Breslau

Stuttgart,

Carl Wäcken, Verlagsbuchhandlung.

1853.

Nr. 21284

Ausgeführt in der Buchdruckerei und Anstalt für Lithographie, Farbendruck und Holzgravirung von J. G. Mäcken Sohn in Reutlingen.

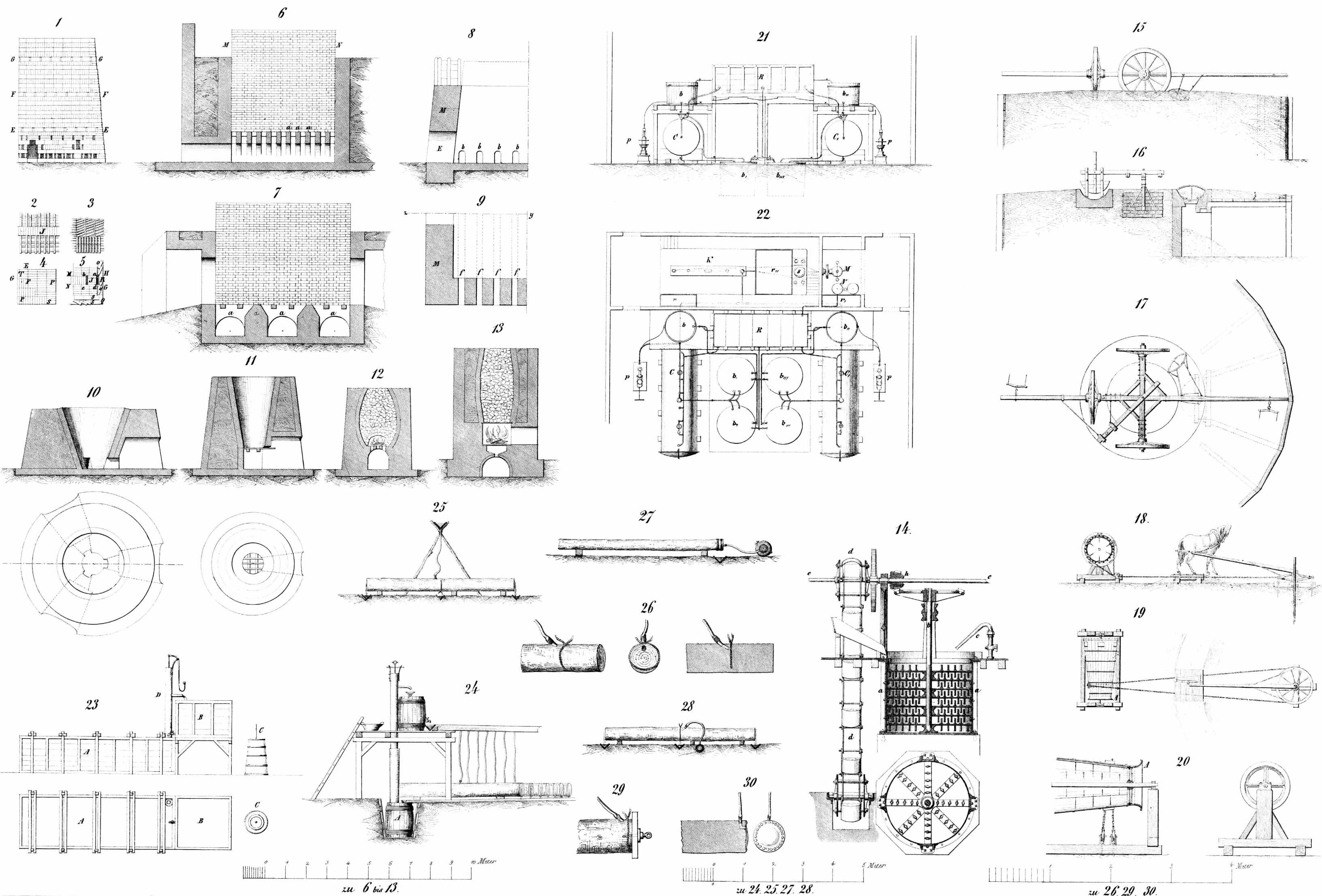

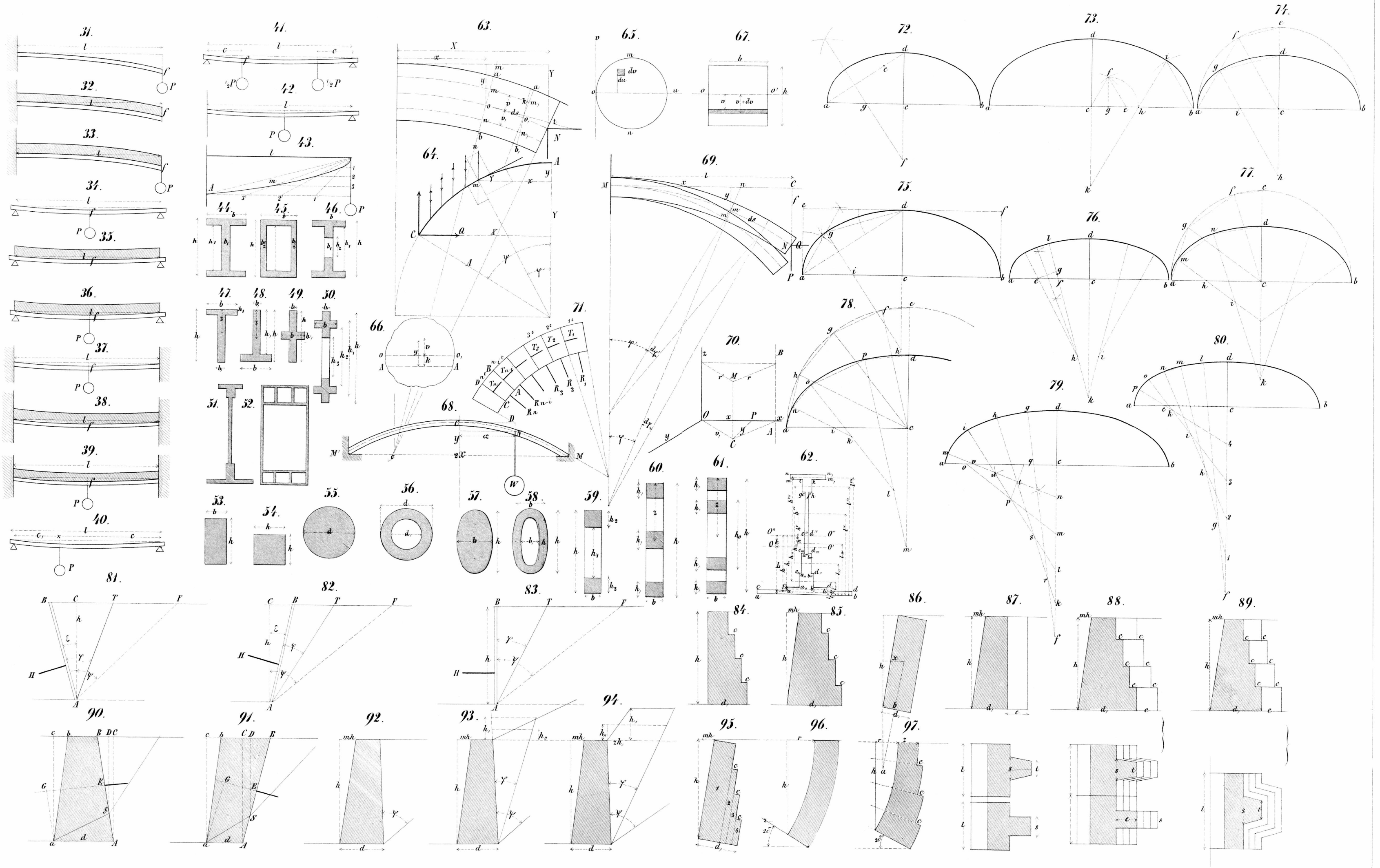

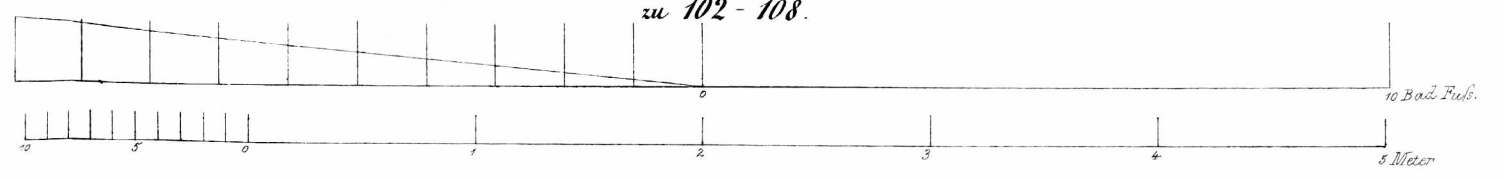
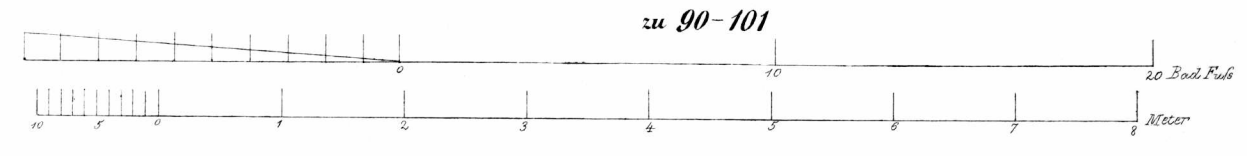
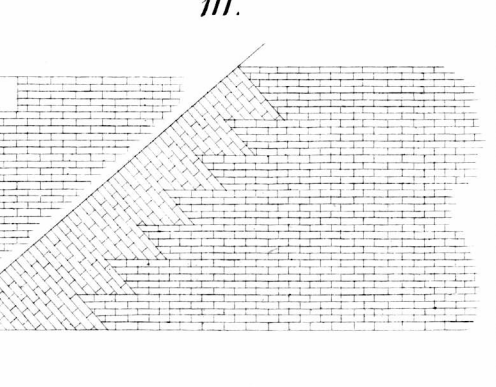
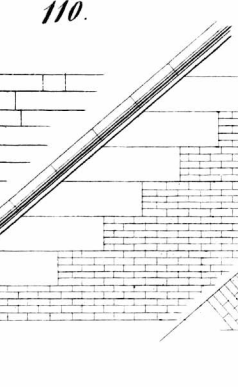
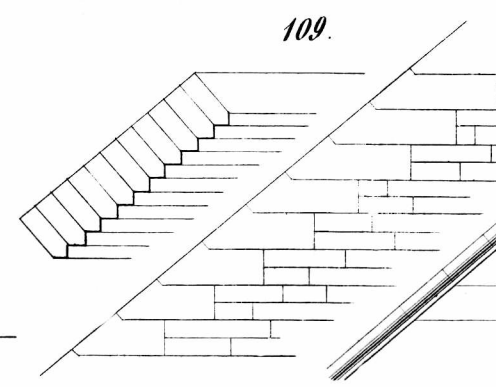
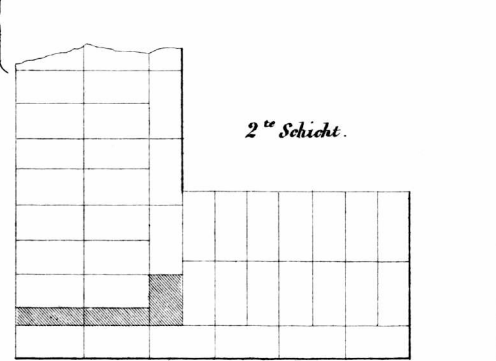
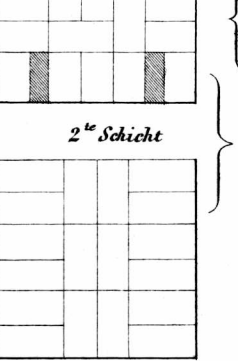
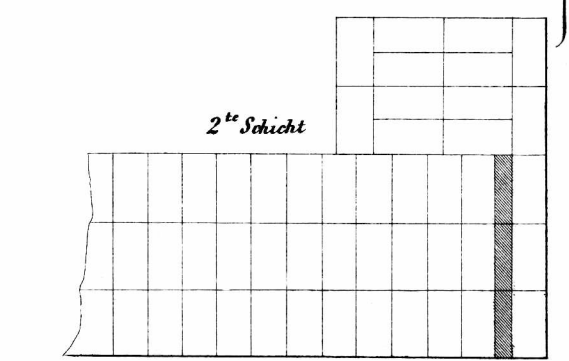
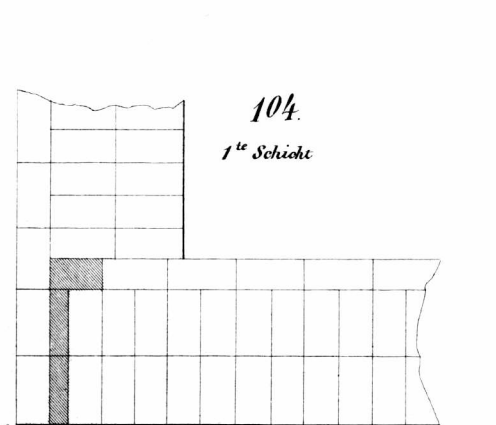
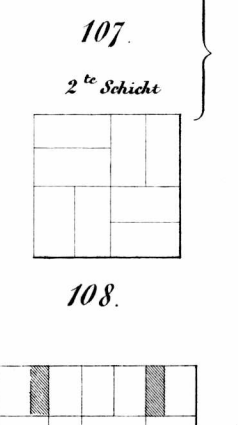
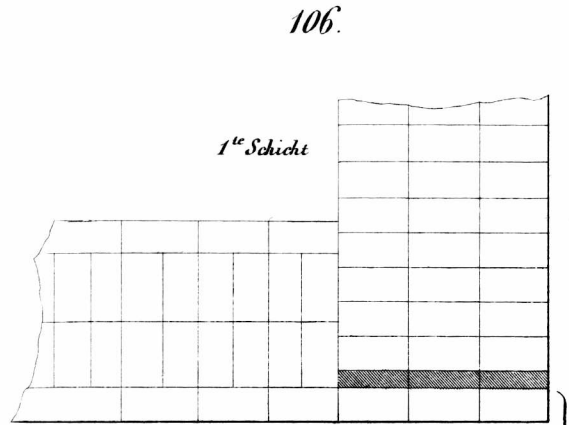
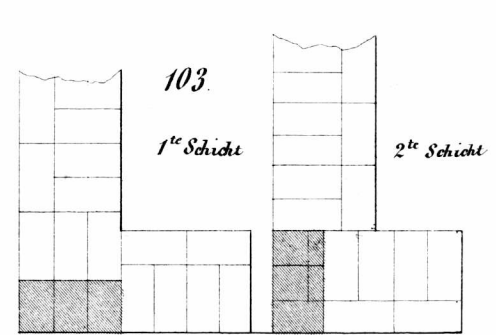
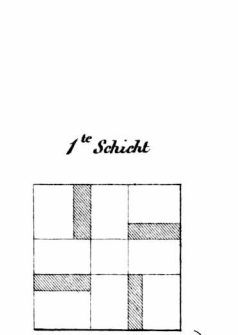
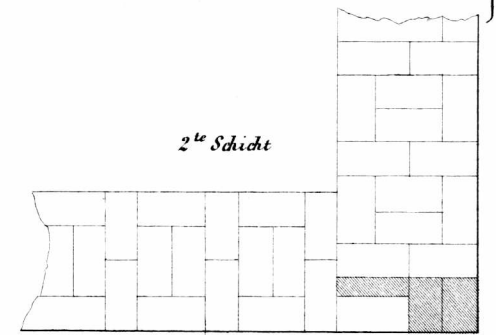
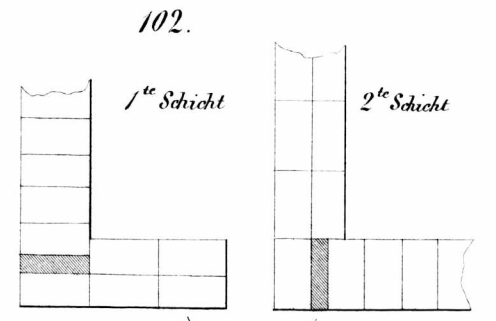
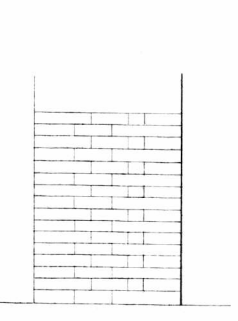
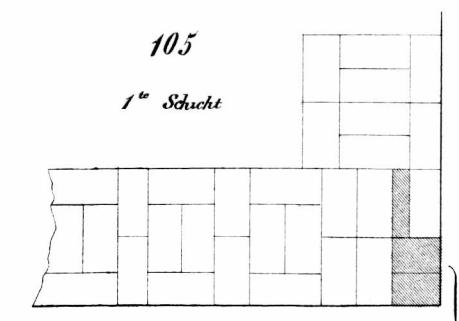
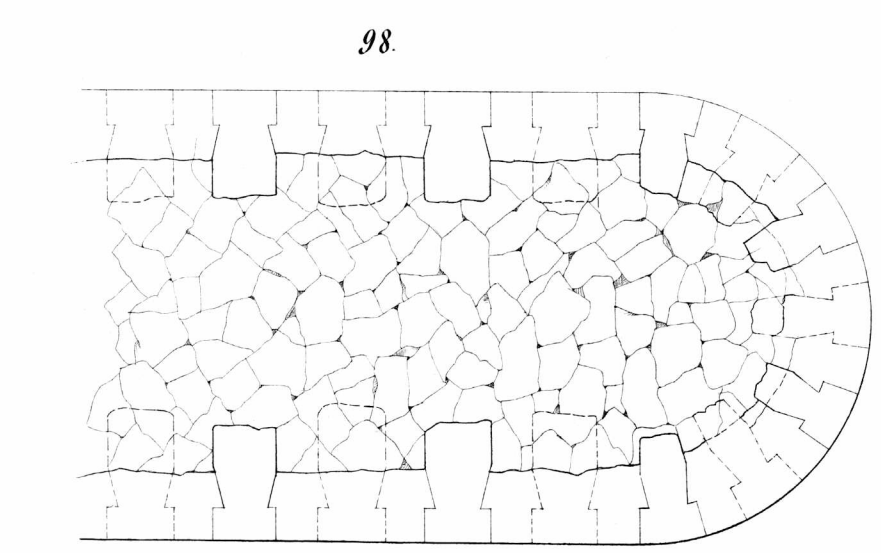
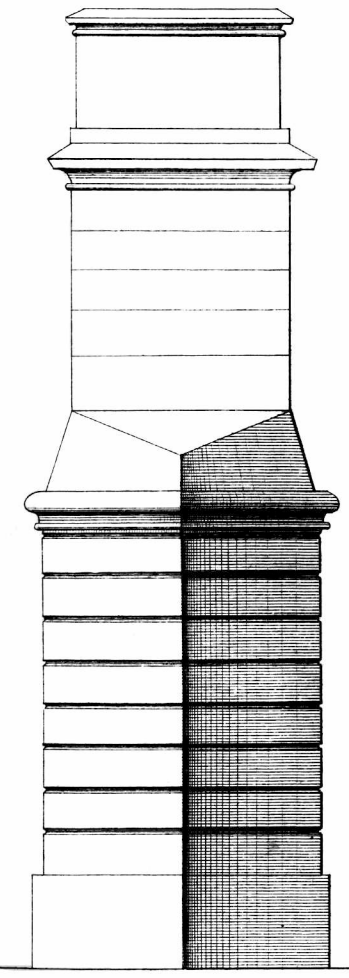
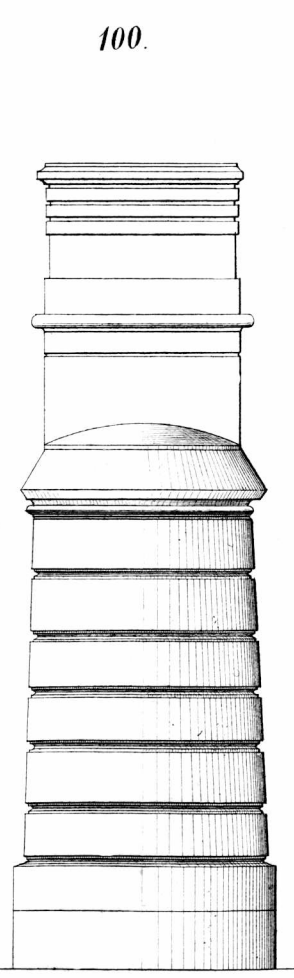
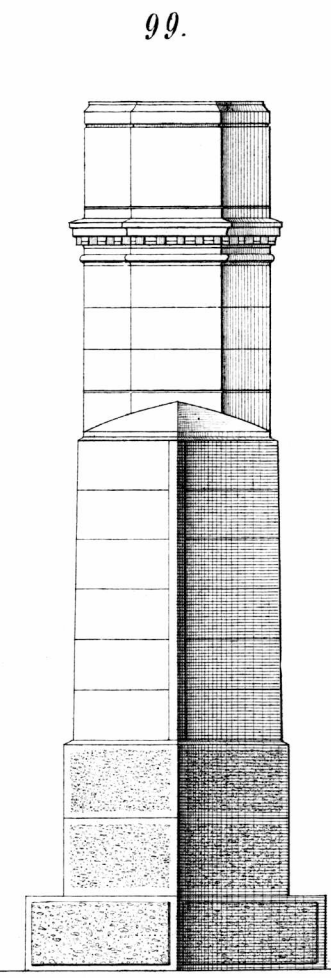
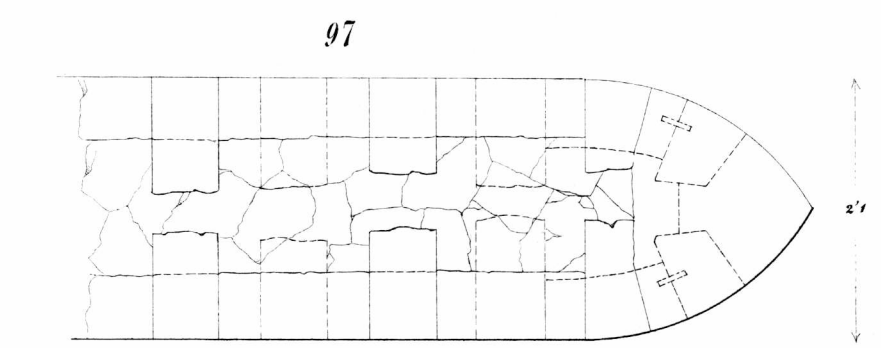
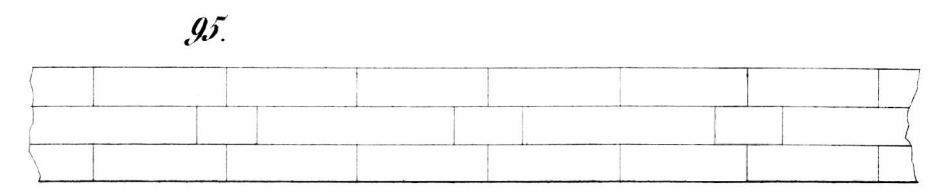
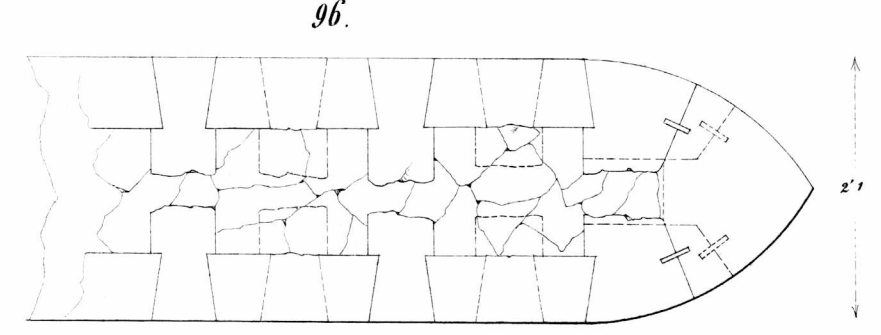
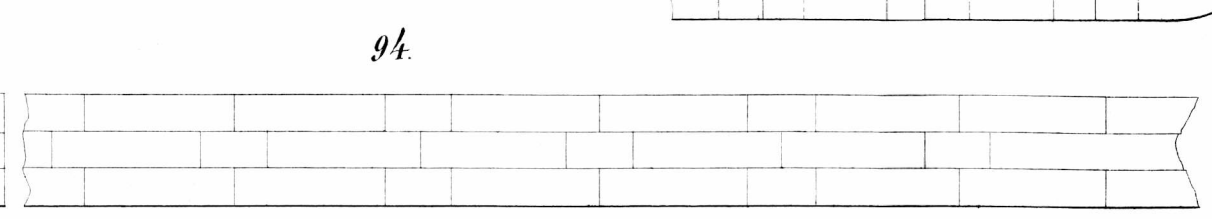
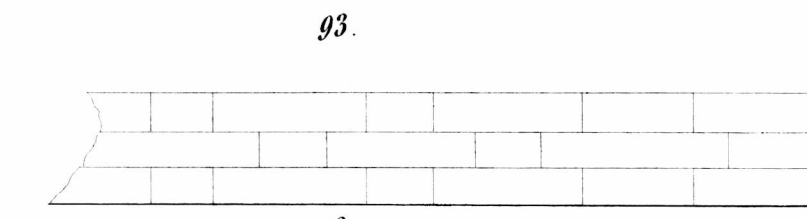
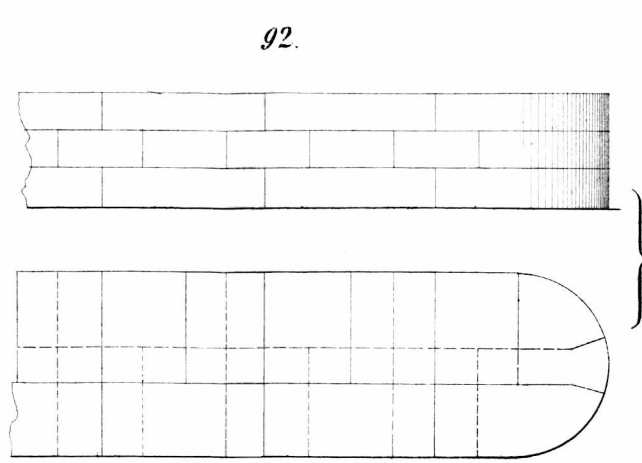
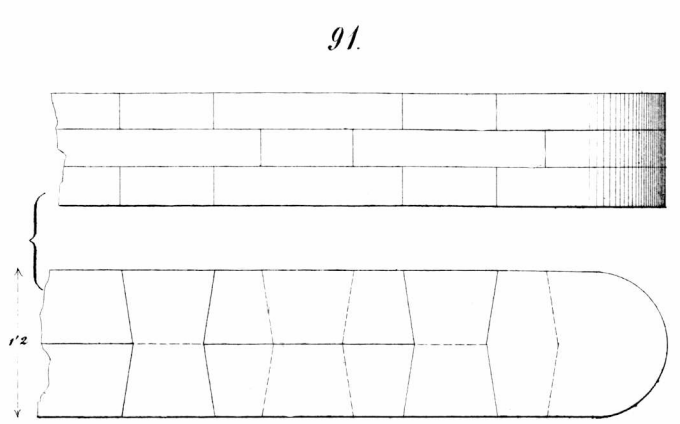
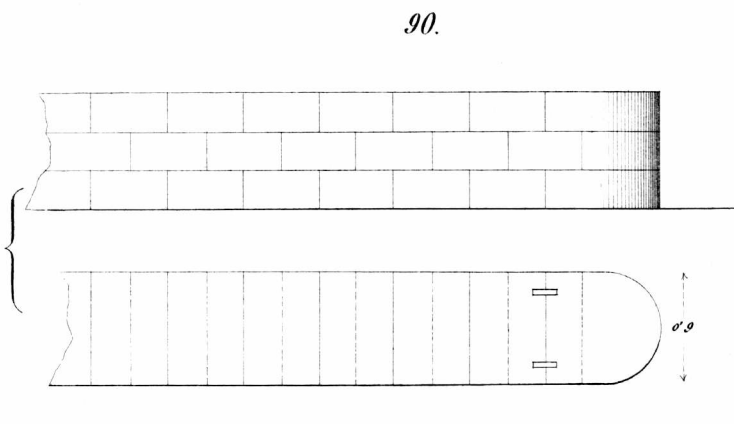

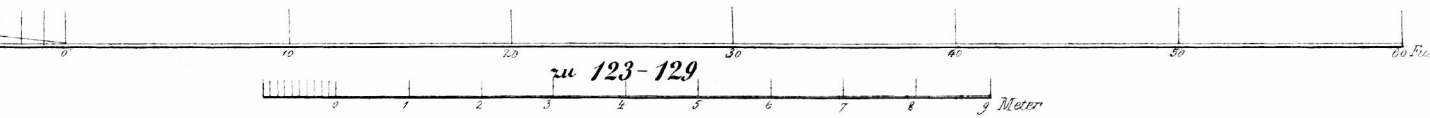
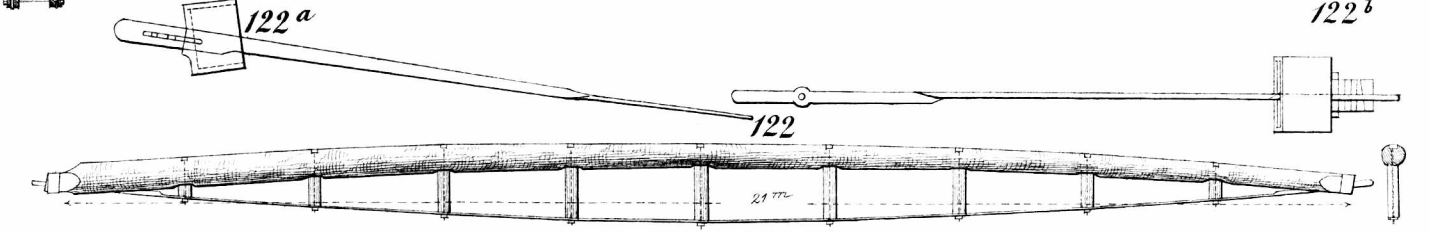
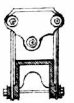
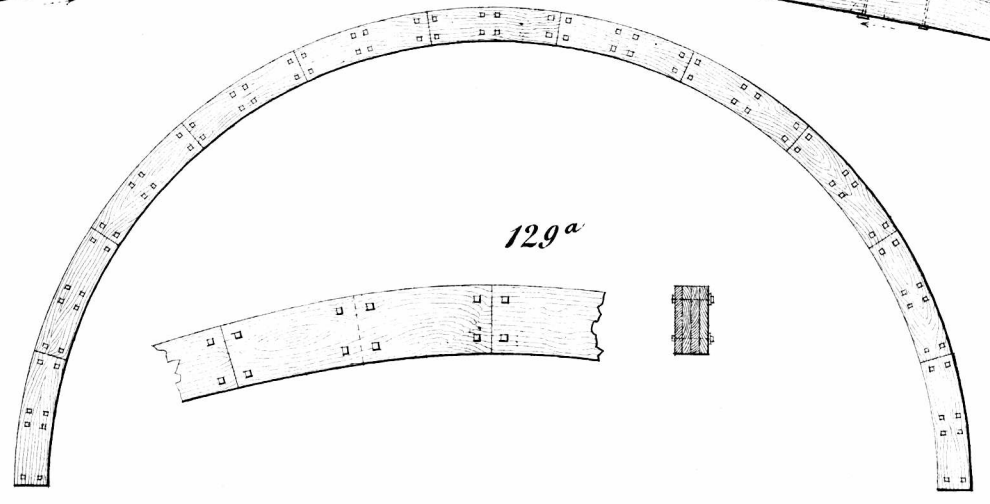
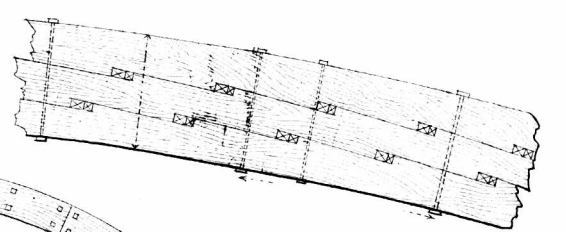
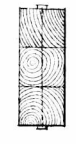
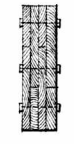
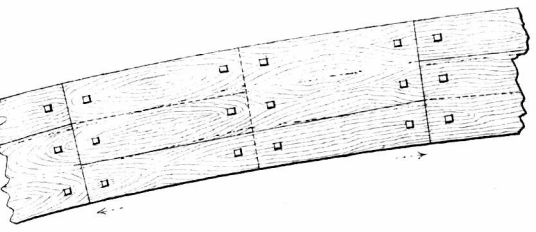
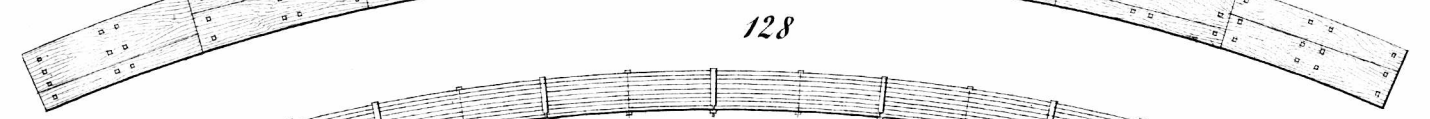
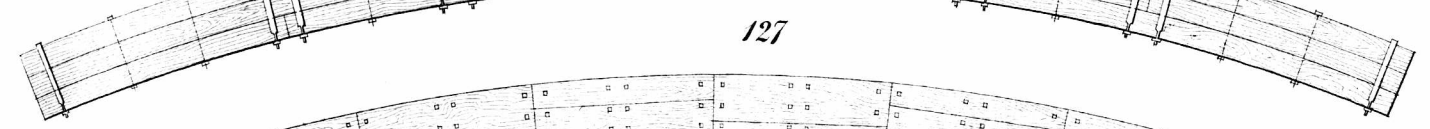
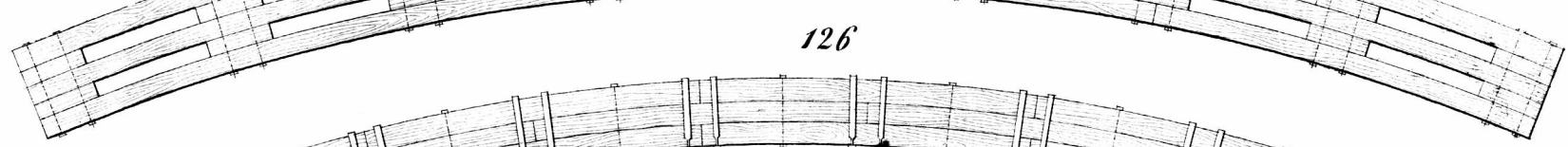
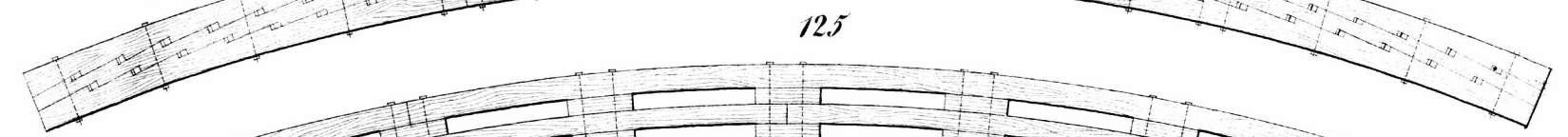
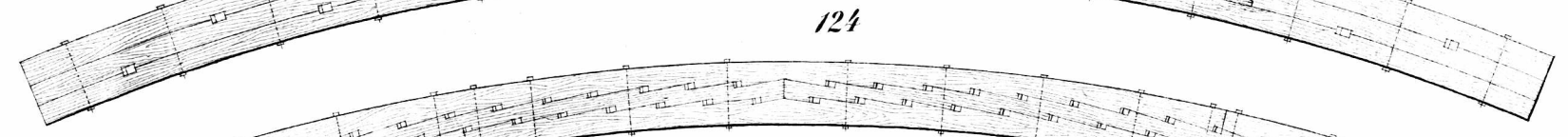
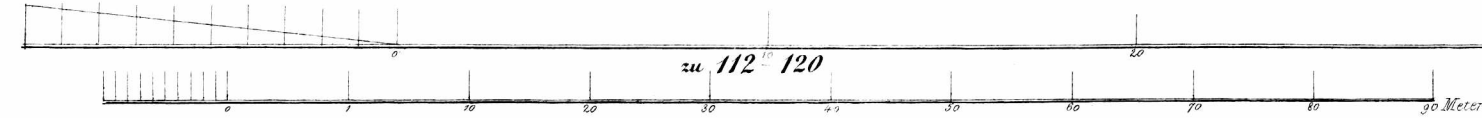
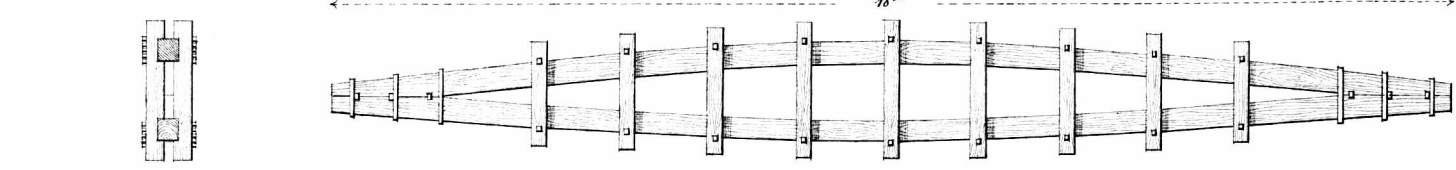
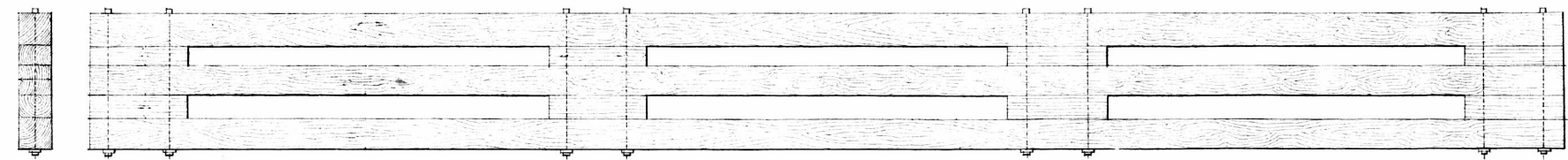
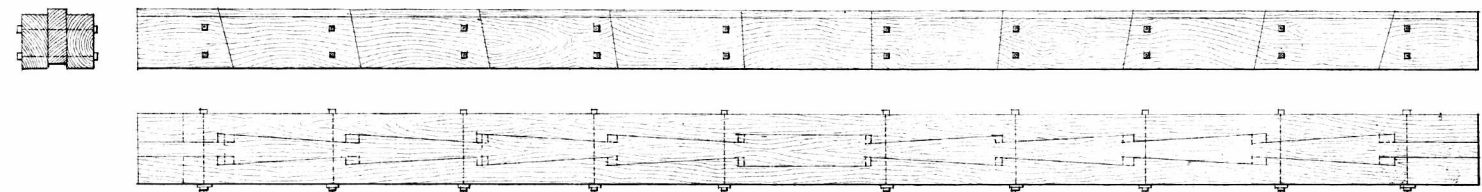
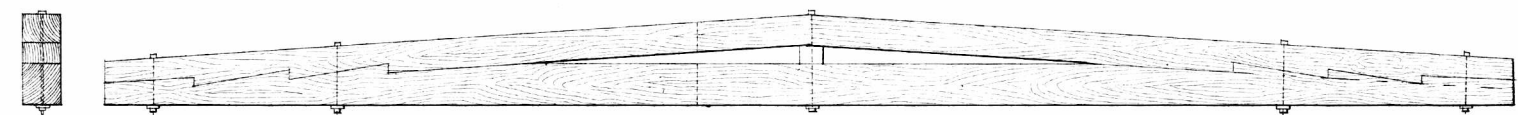
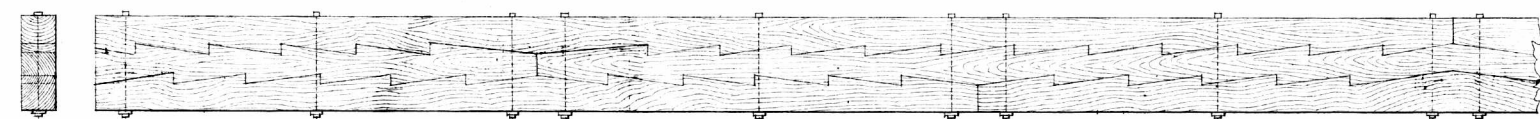
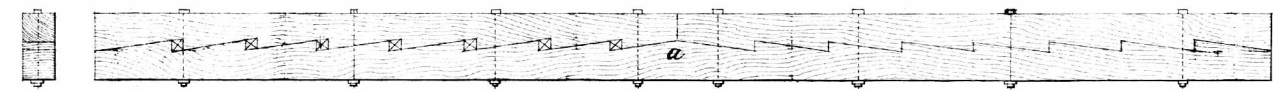
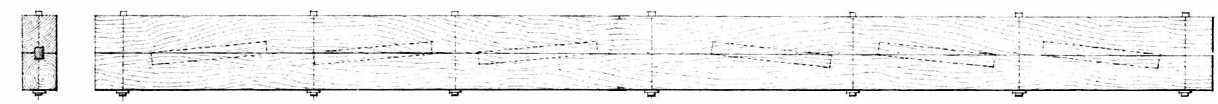
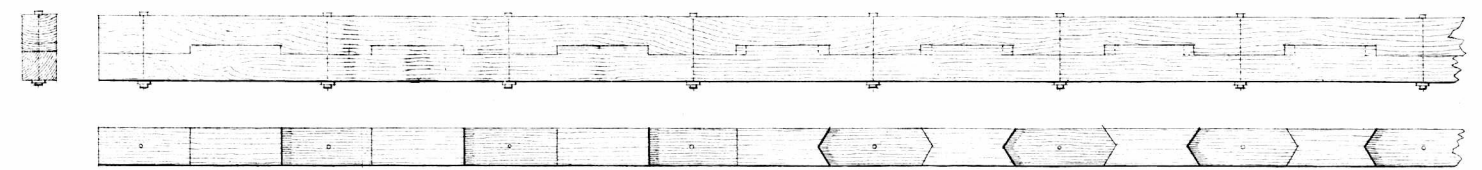
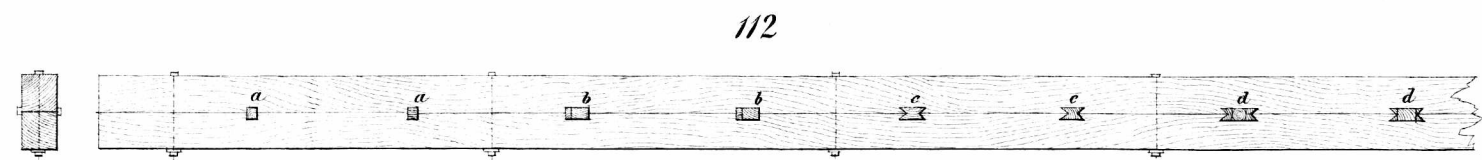

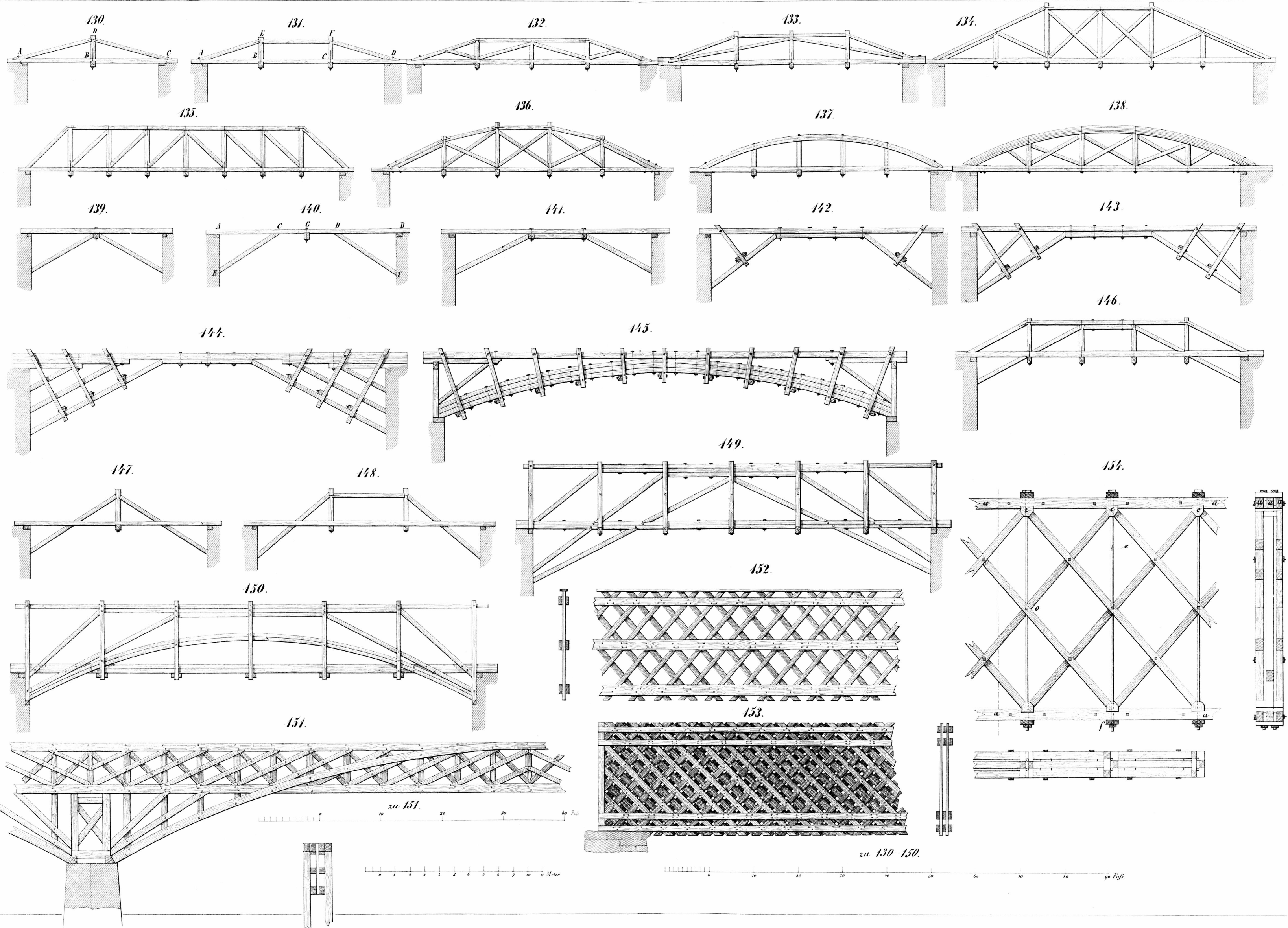

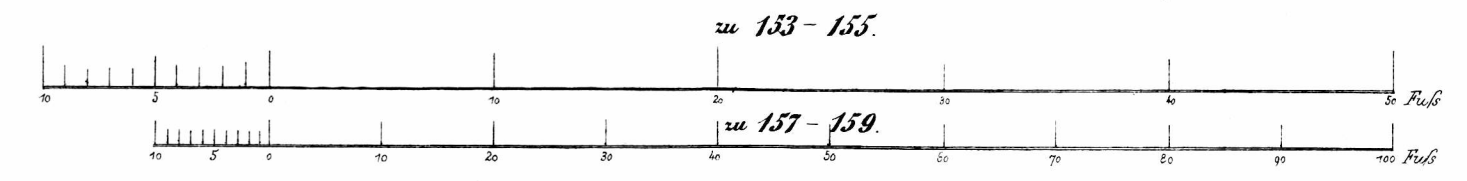
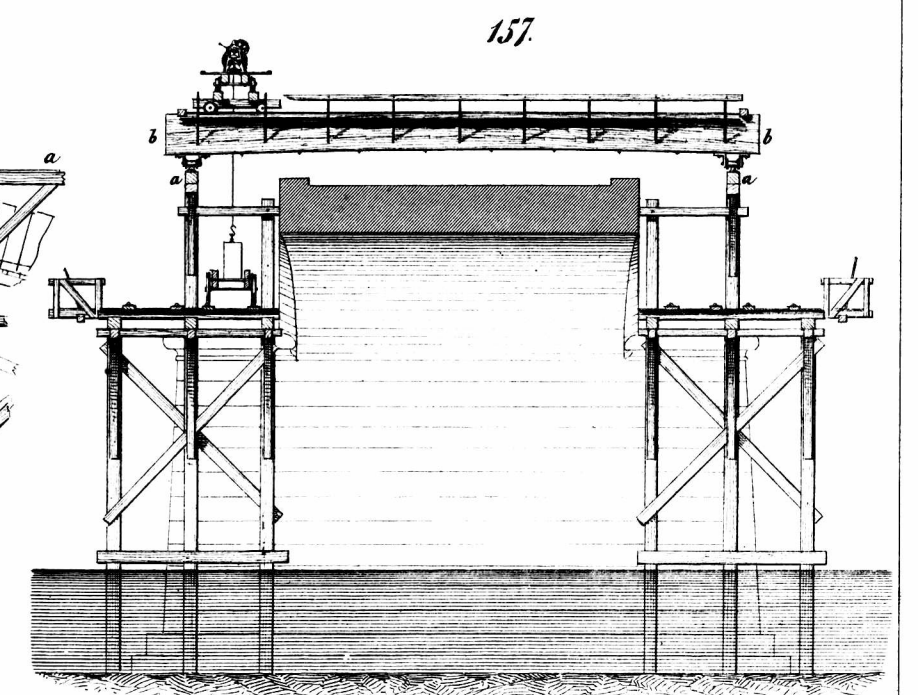
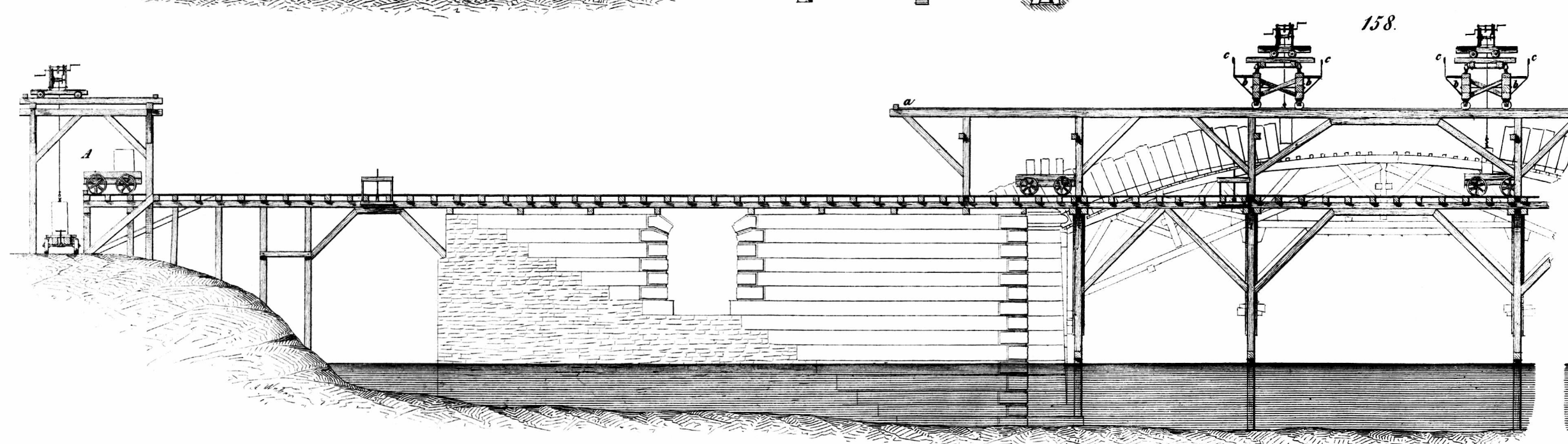
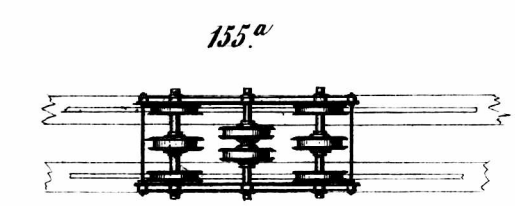
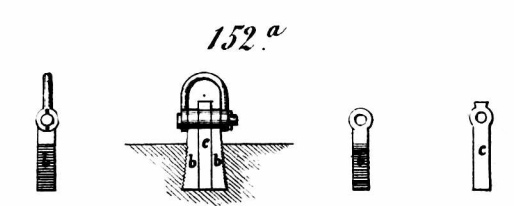
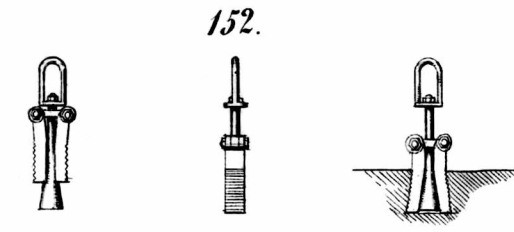
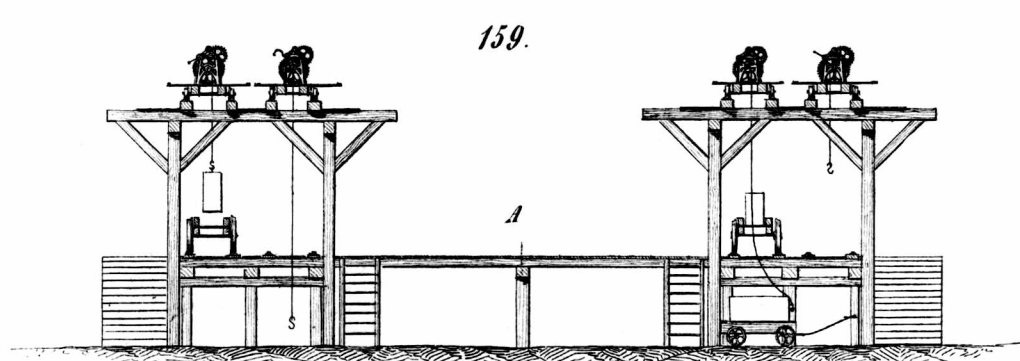
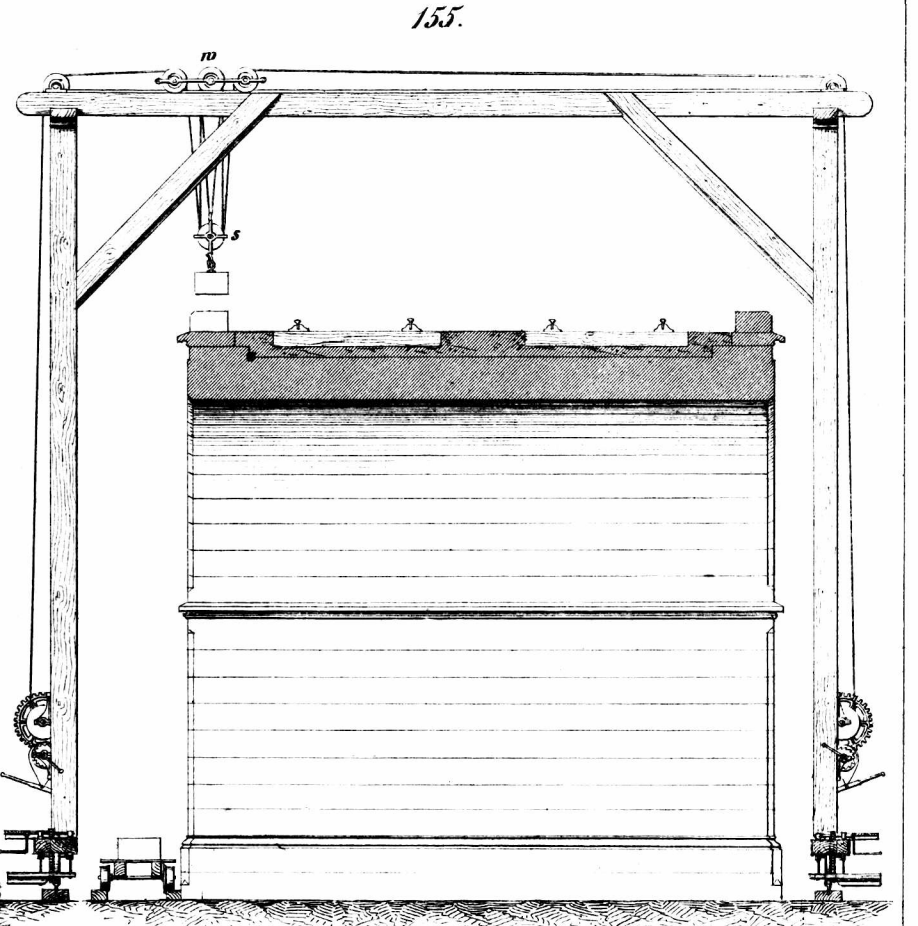
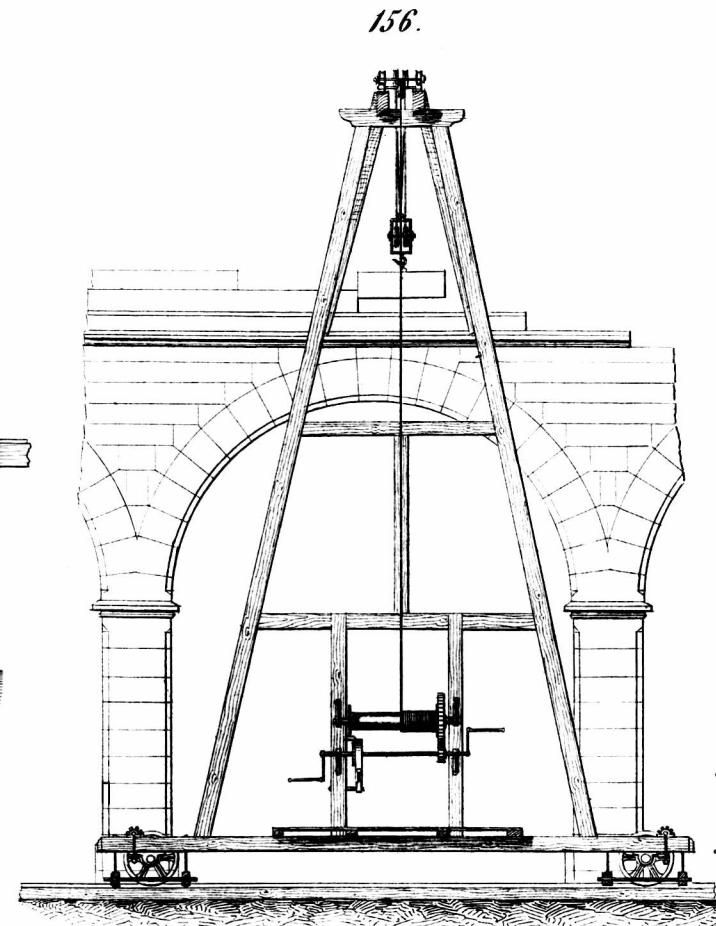
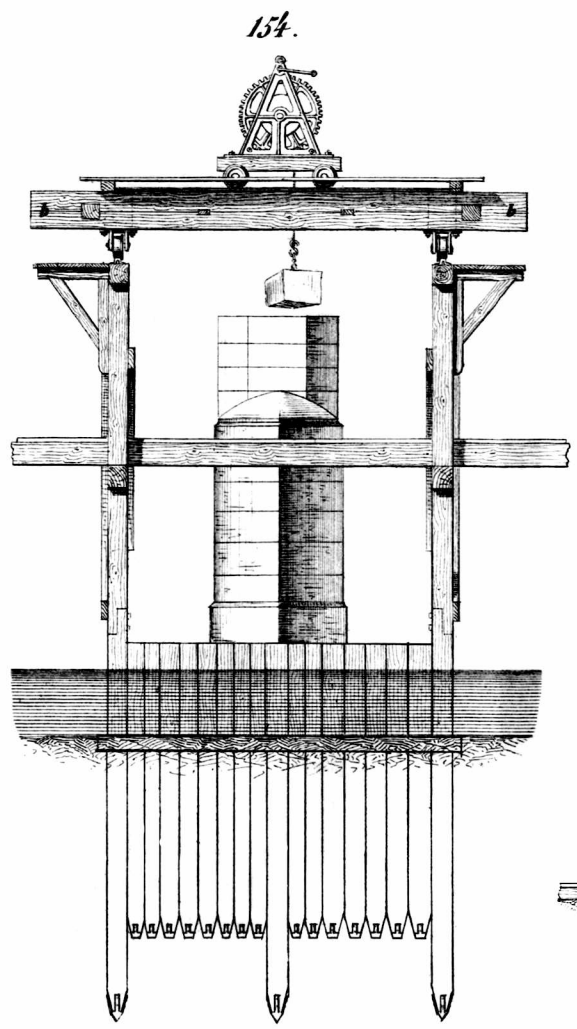
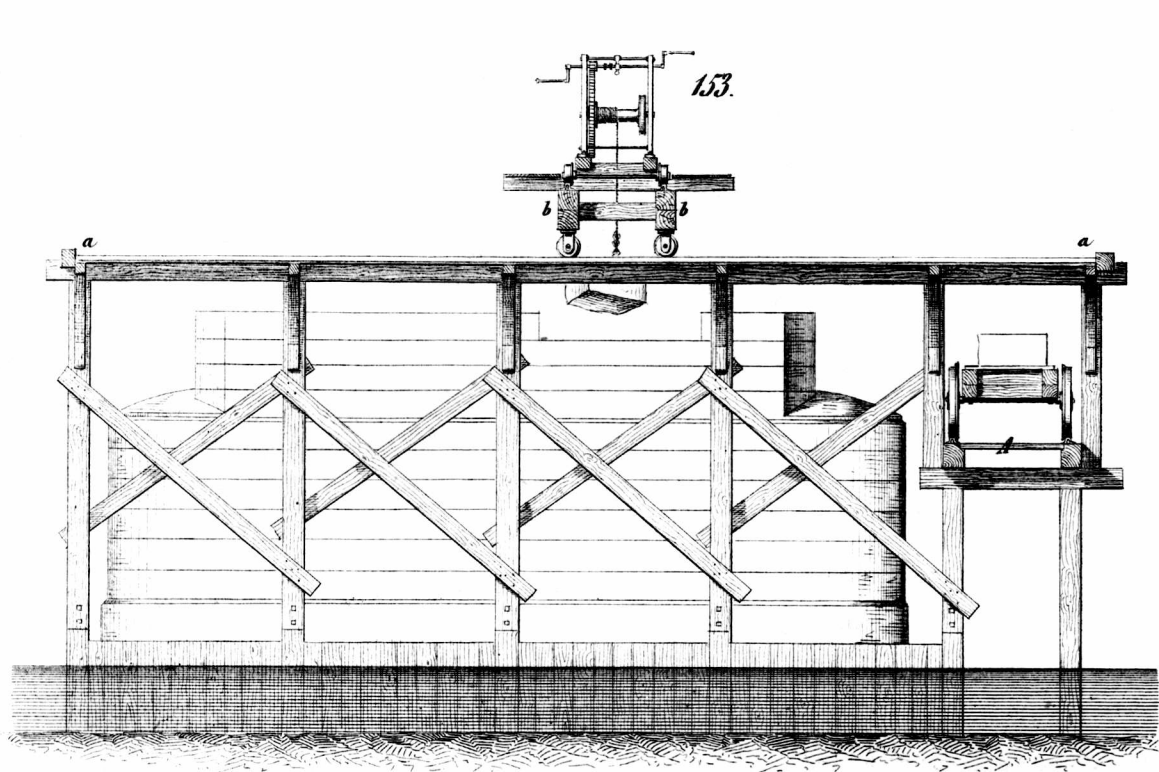

160.

161.

162.

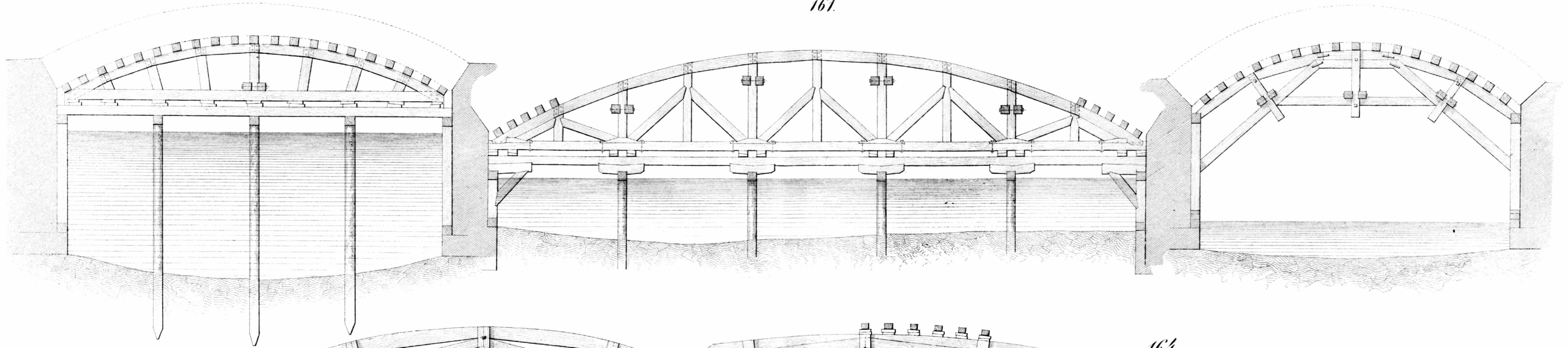

163.

164.

165.

166.

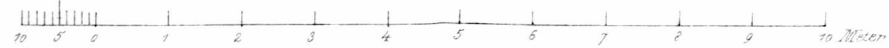
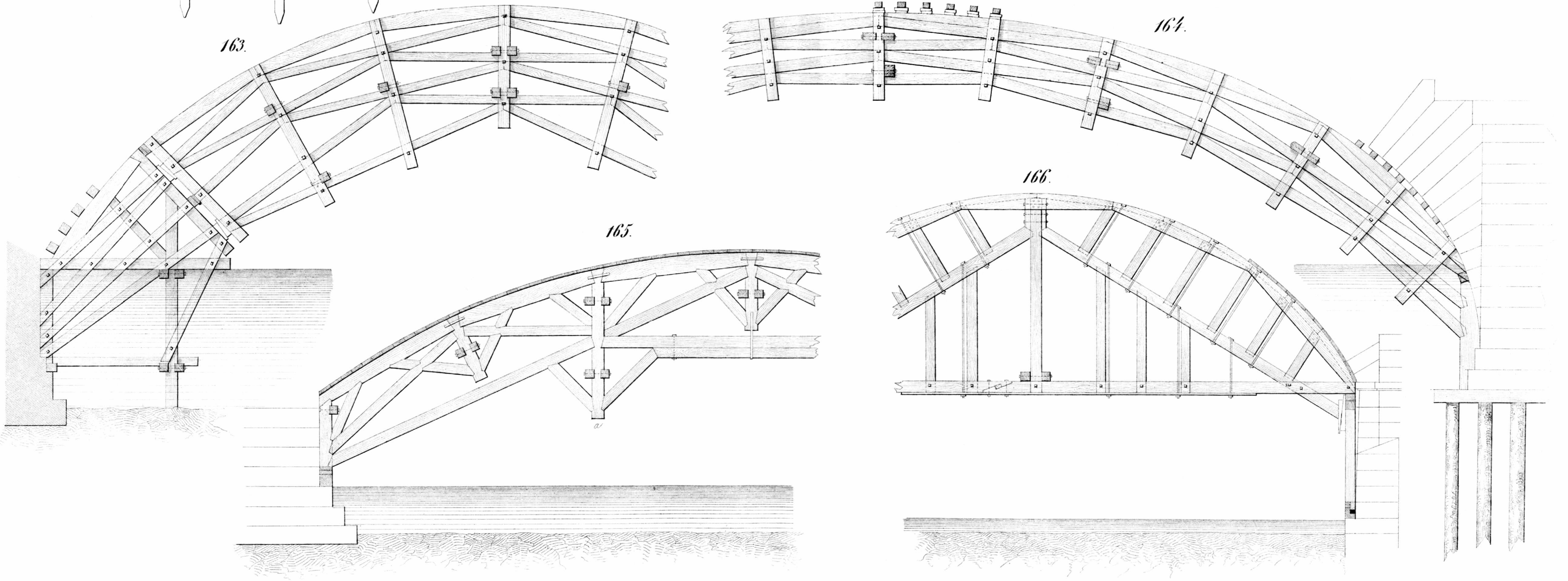

167.

168.

169.

170.

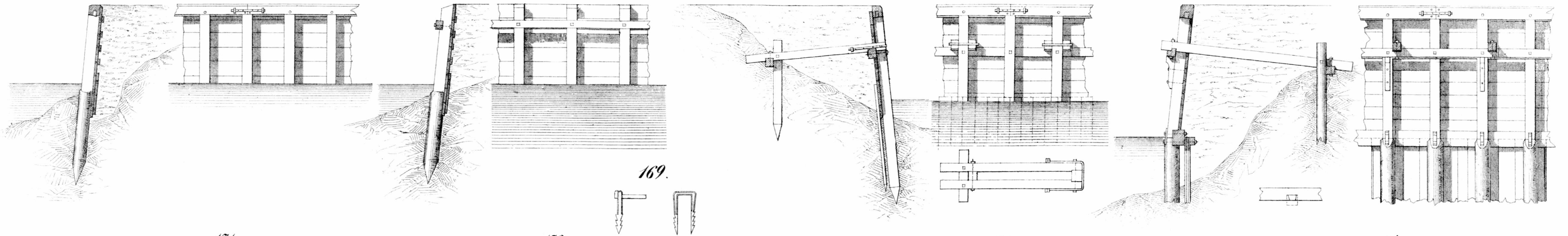

169.

171.

172.

173.

174.

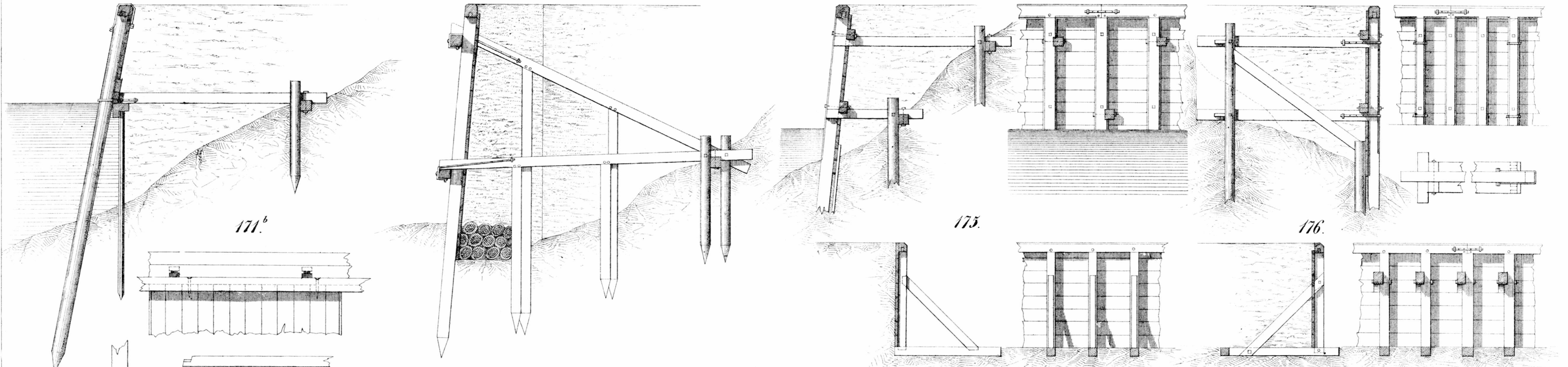

171.^b

175.

176.

172.^a

177.

178.

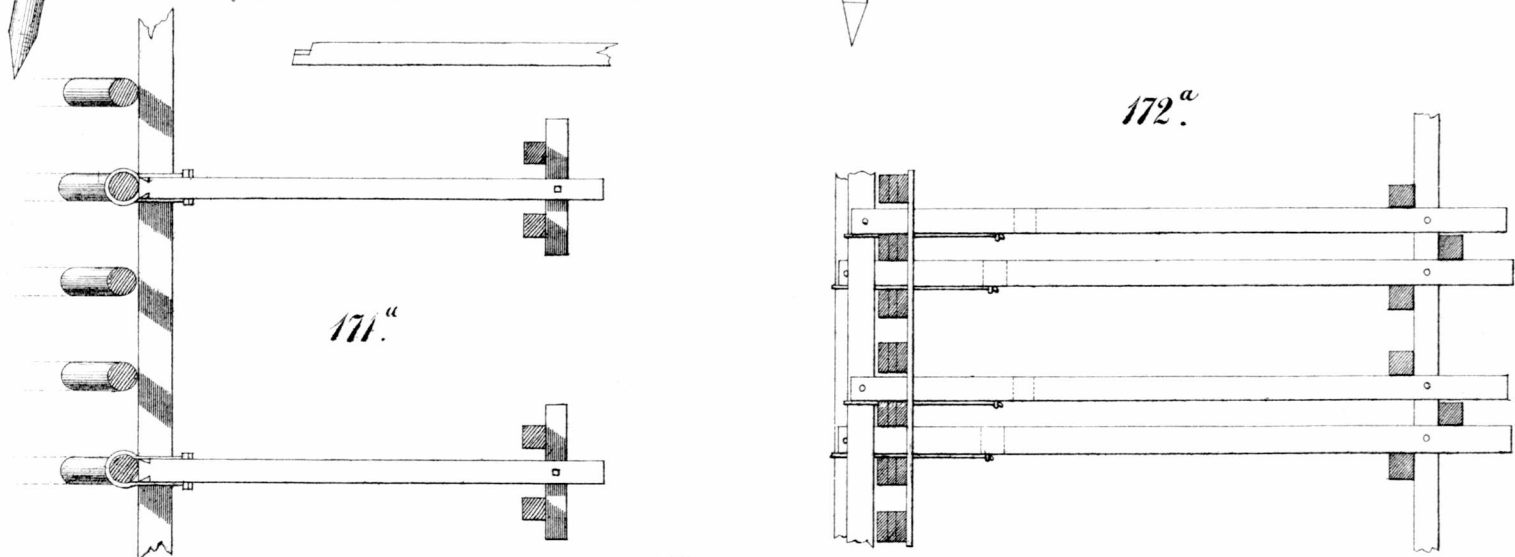

zu 167-178.

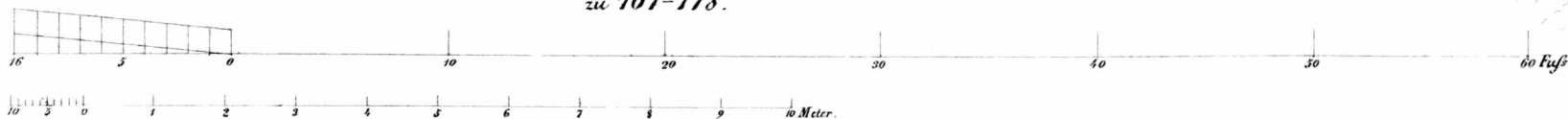

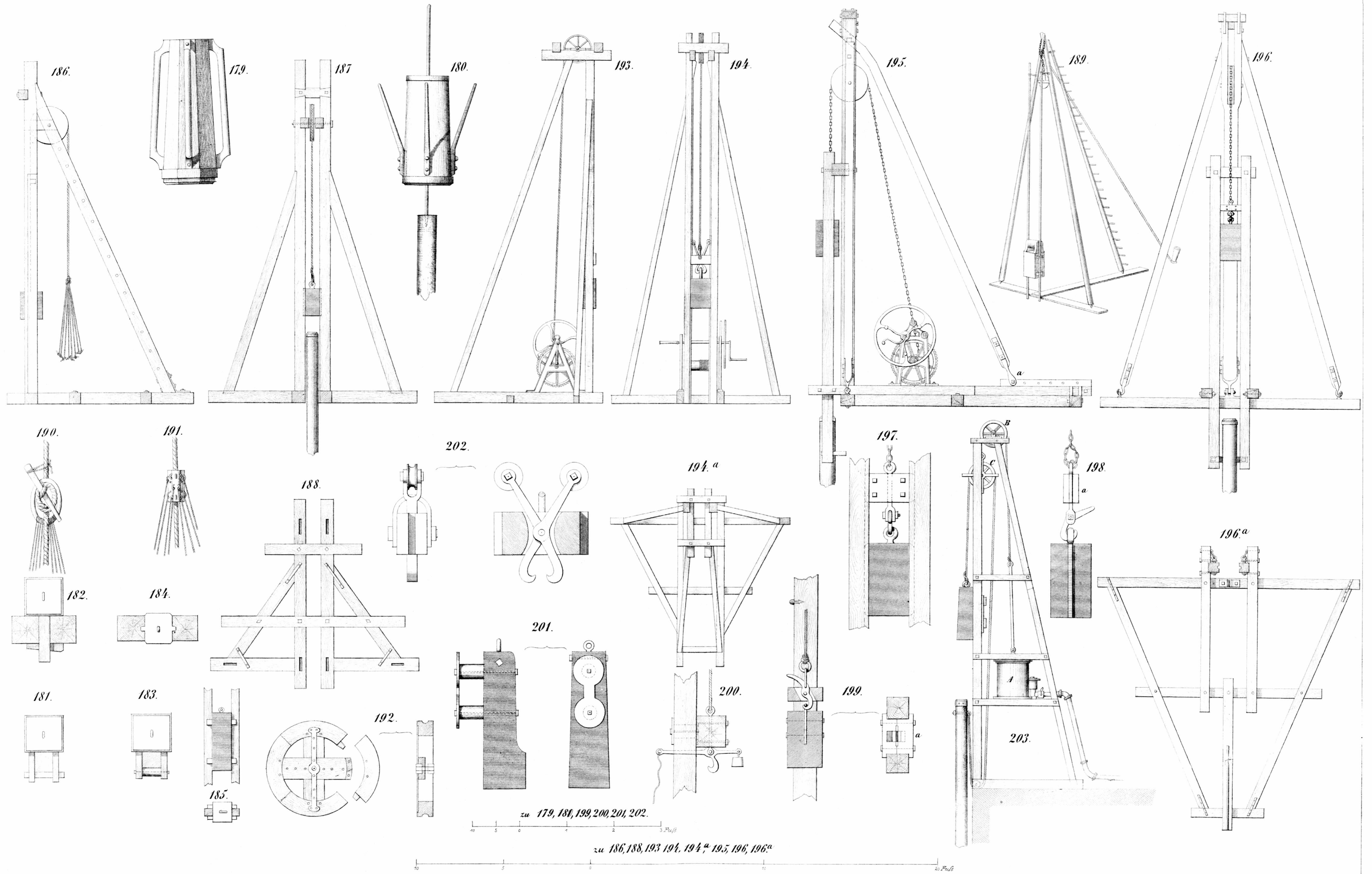

204.

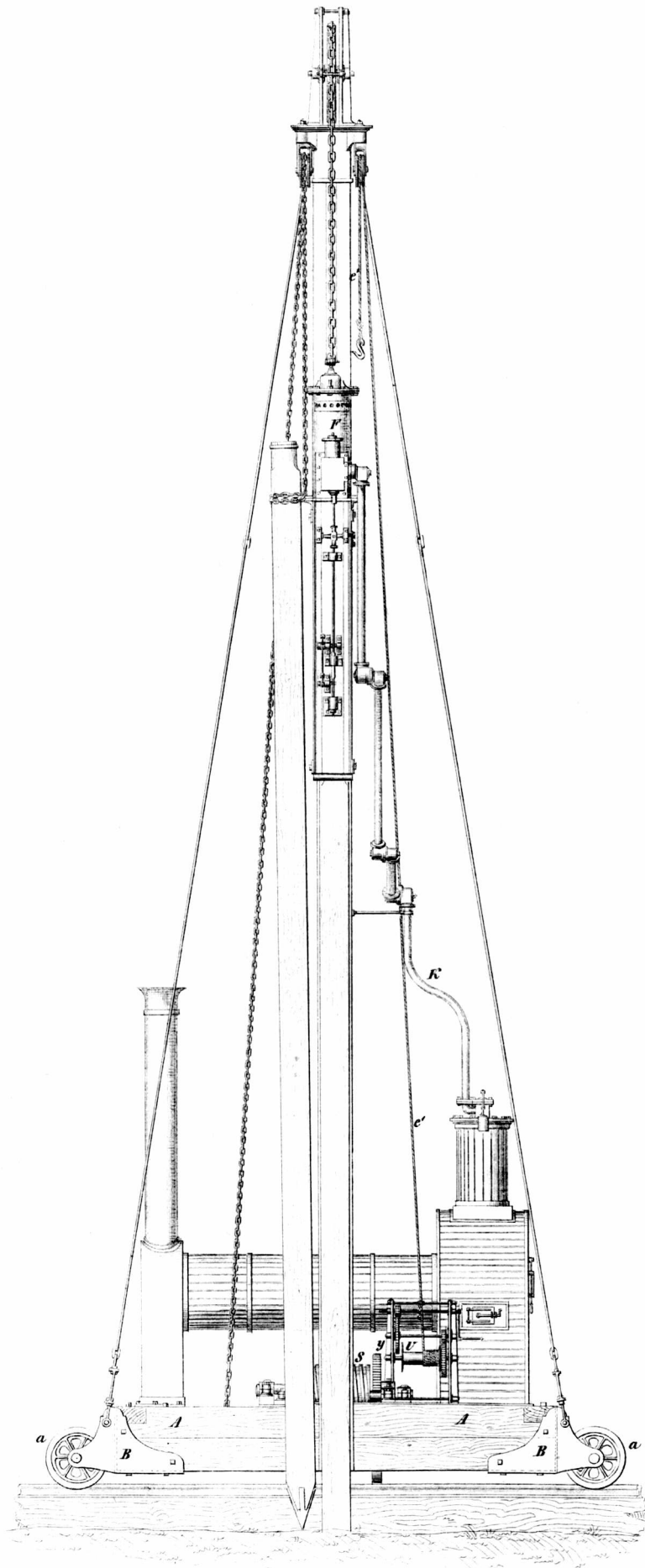

205.

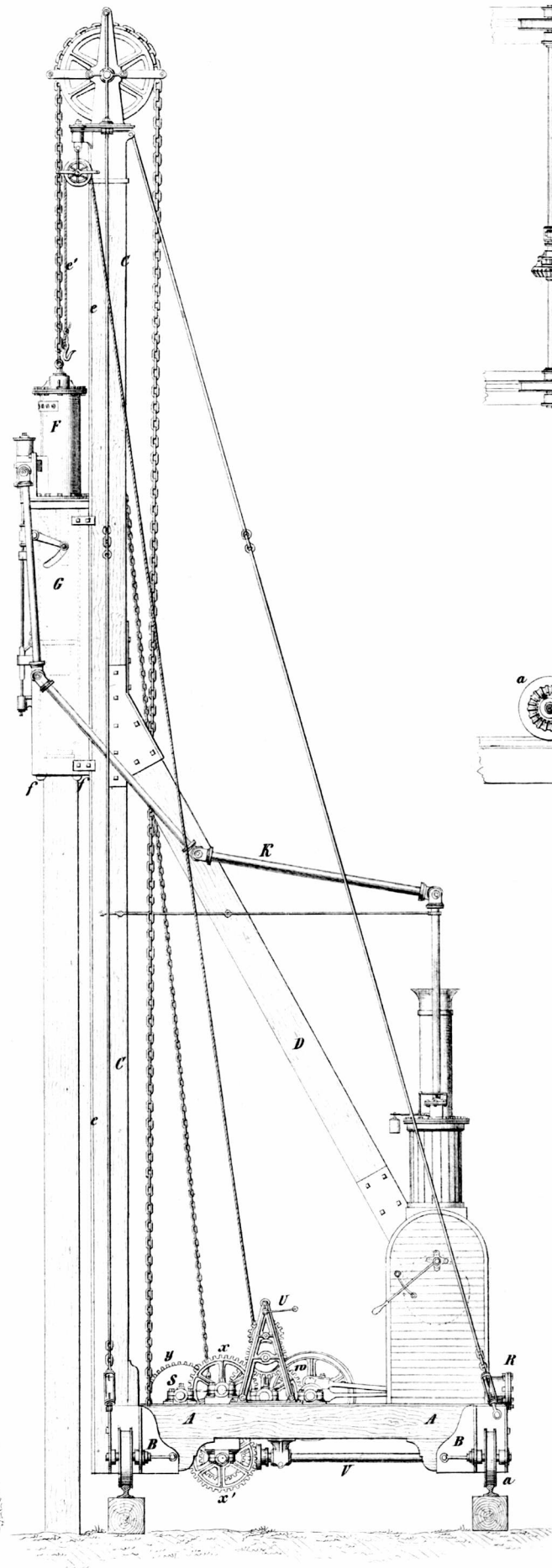

206.

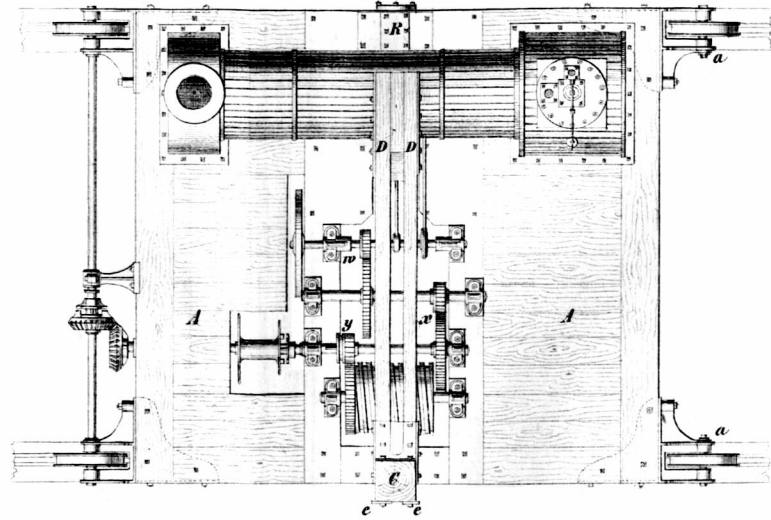

207.

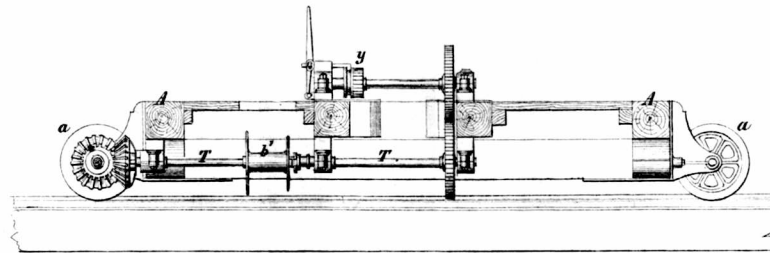

217.

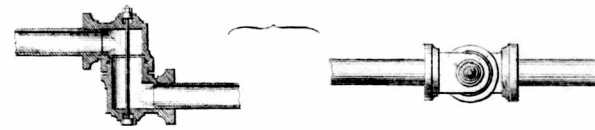

216.

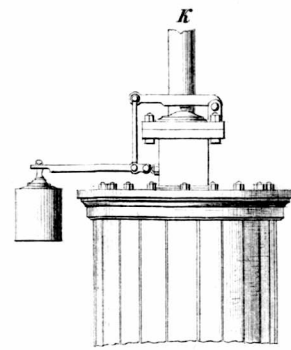

215.

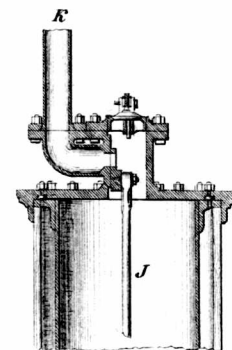

208.

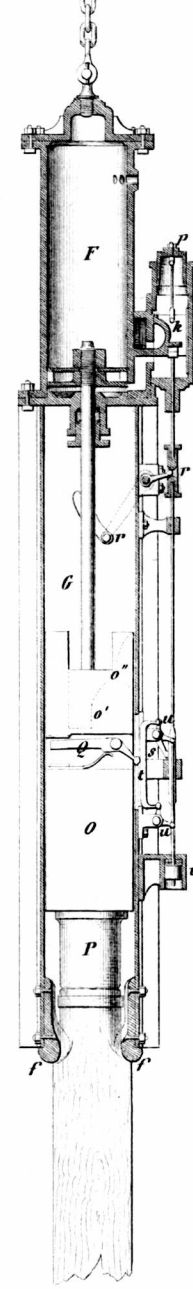

209.

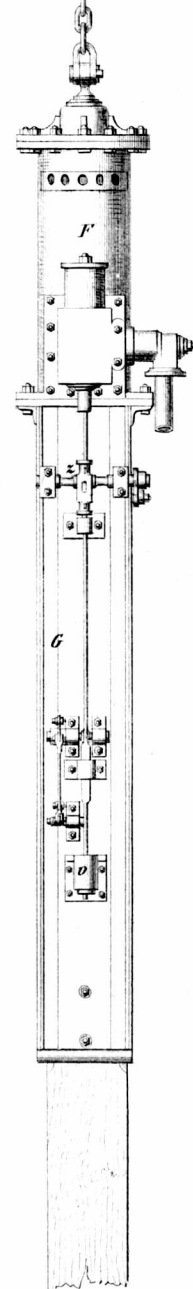

210.

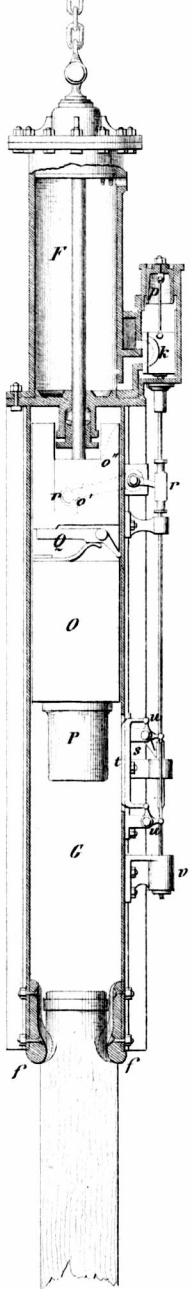

214.

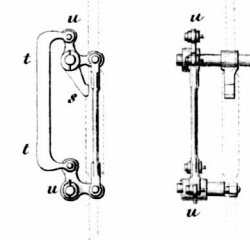

211.

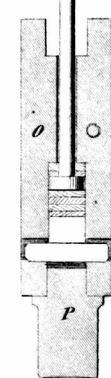

212.

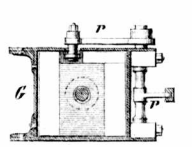

213.

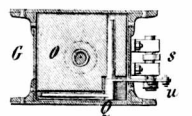

zu 216, 217.

zu 204 - 207.

zu 208 - 213

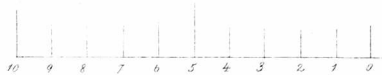

10

20

30 Engl. Fu^s

12

1

2

3

4

5

6

7

8

9

10

11

12

13

14

15

16

17

18

19

20

21

22

23

24

25 Engl. Fu^s



12

6

0

1

2

3

4

5

6

7

8

9

10

11

12

13

14

15

16

17

25 Engl. Fu^s

Meter

218.

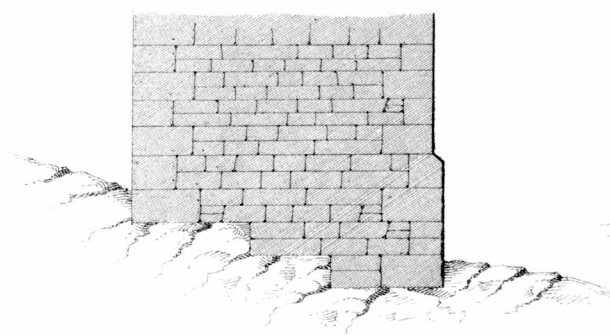

219.

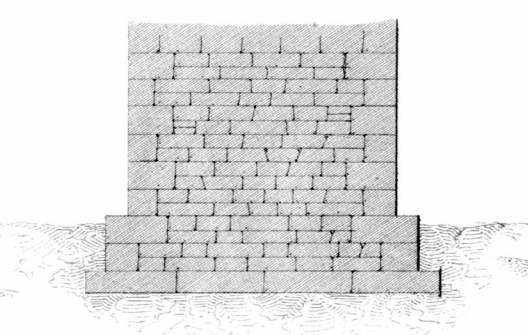

220.

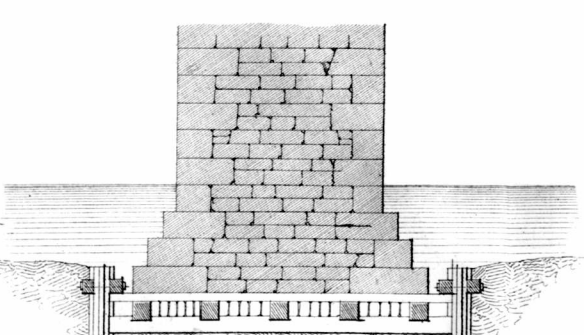

221.

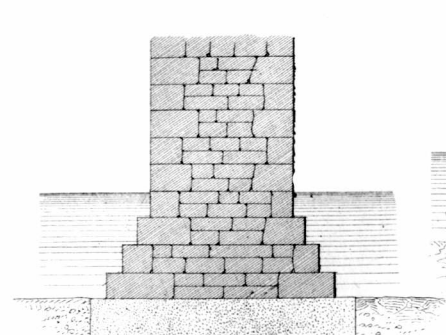

222.

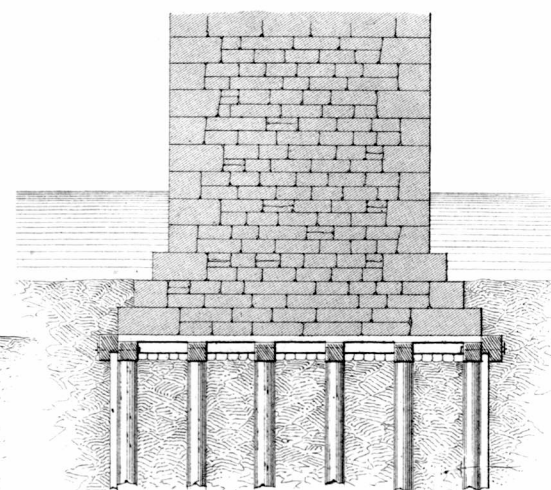

223.

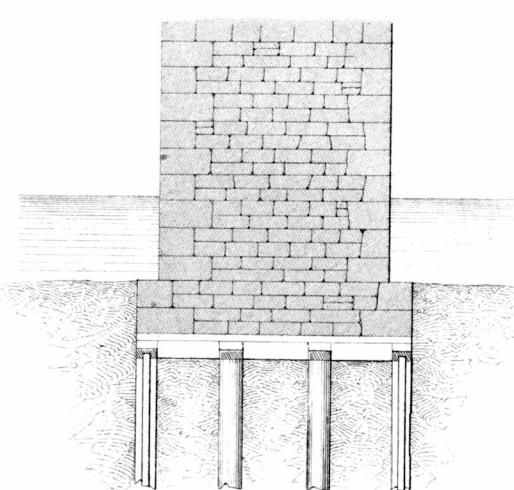

zu 218-226, 229

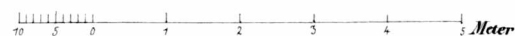

224.

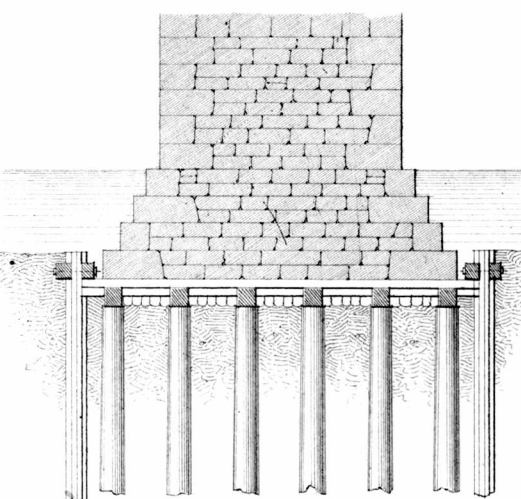

225.

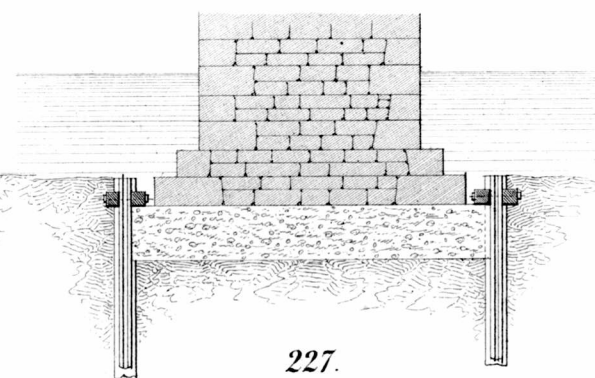

220^a

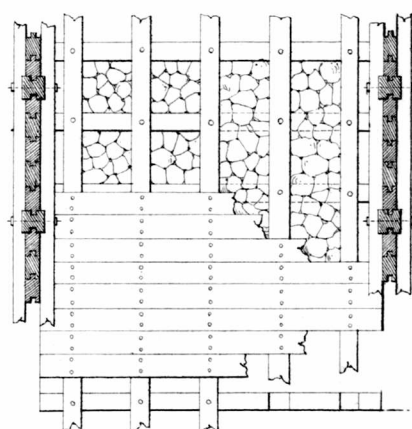

222^a

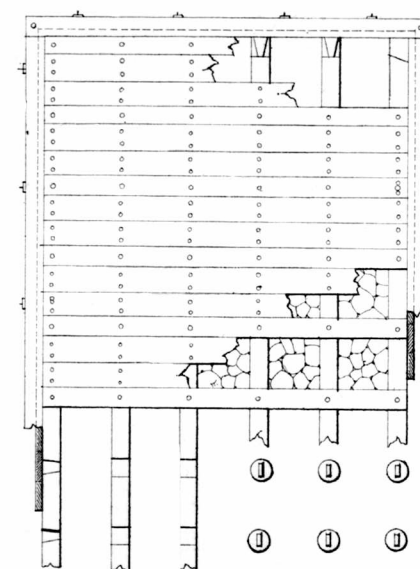

223^a

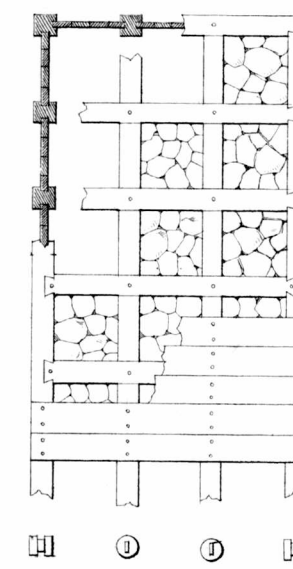

zu 228

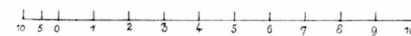

228.

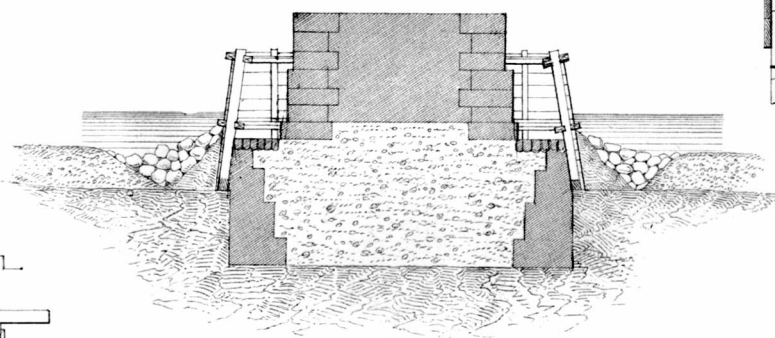

232.



226.

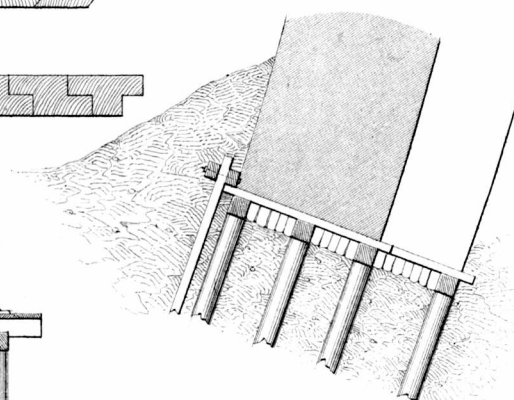

233.

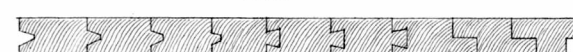

230.

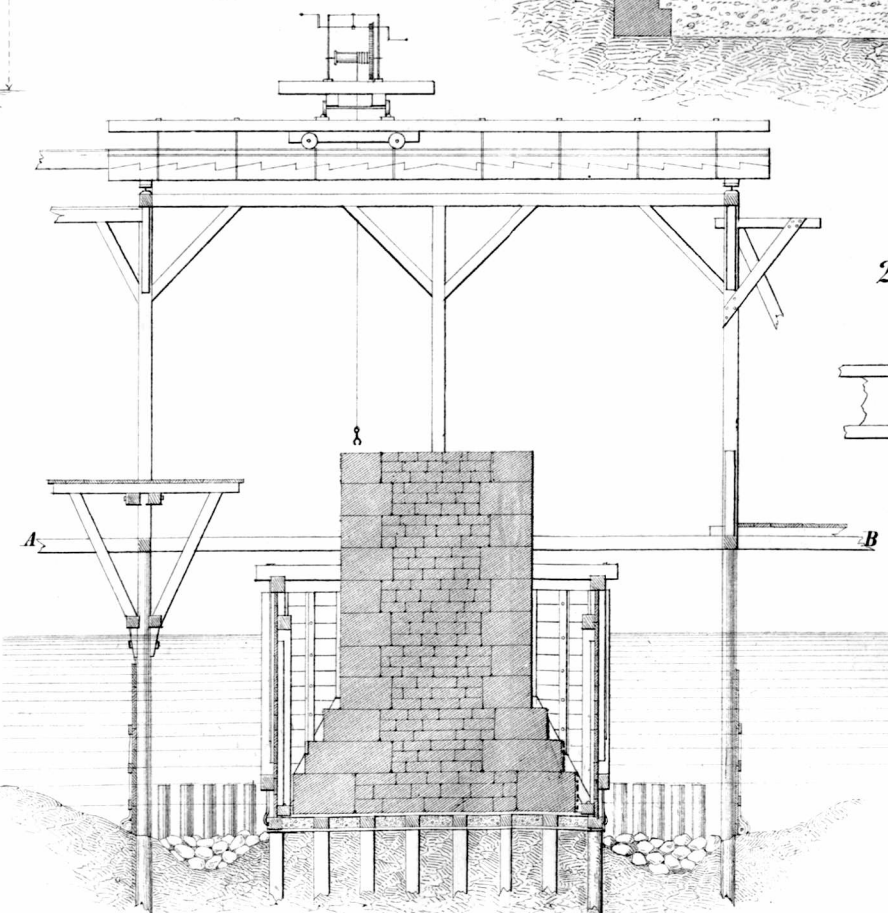

231^b

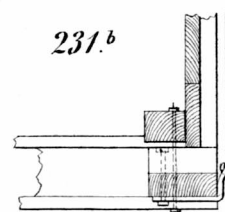

229.

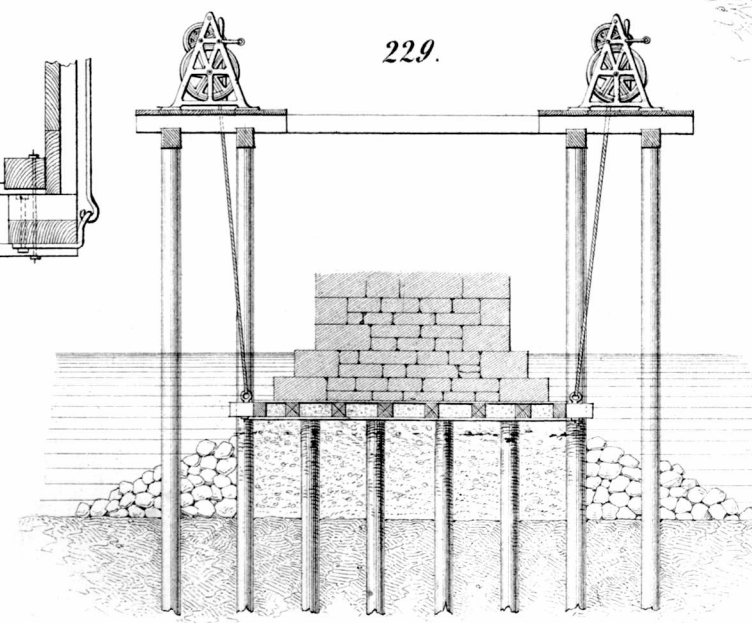

226^a

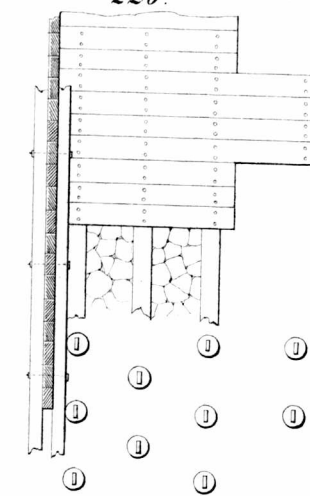

231^a

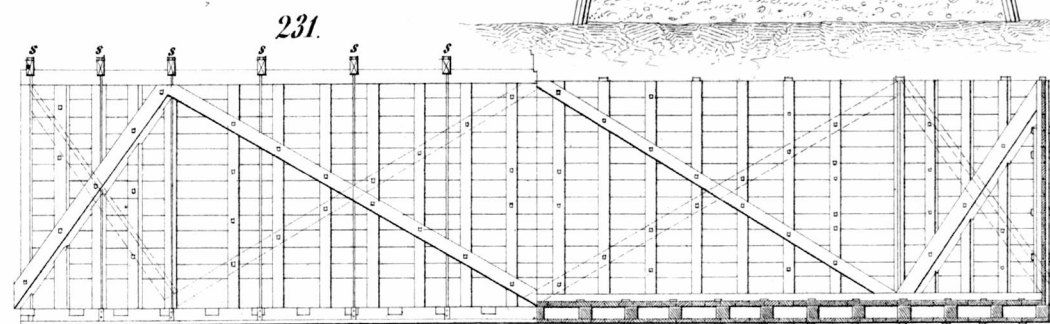

zu 230, 231, 231^a

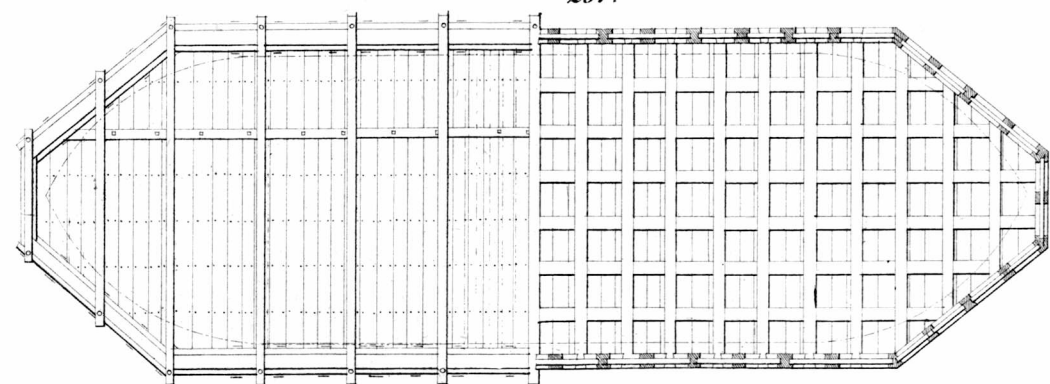
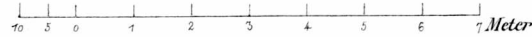

234

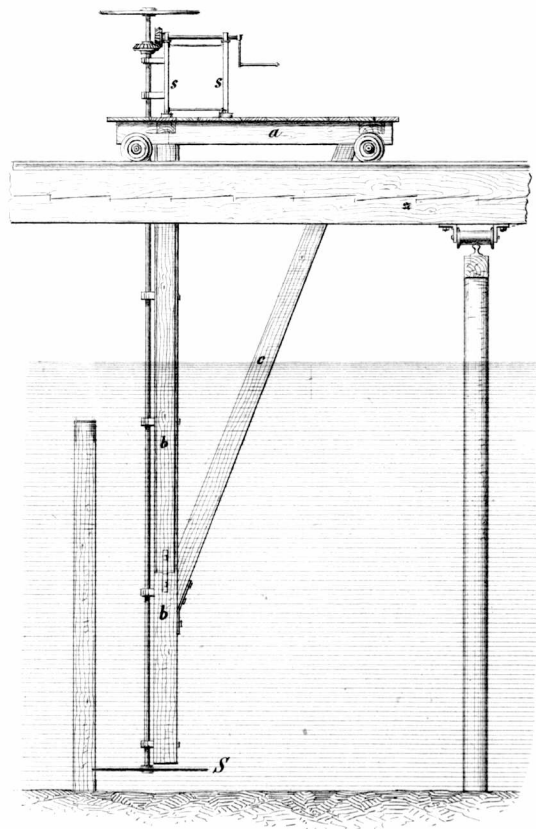

234.b

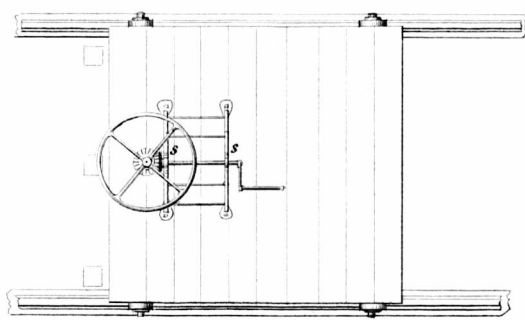

234.a

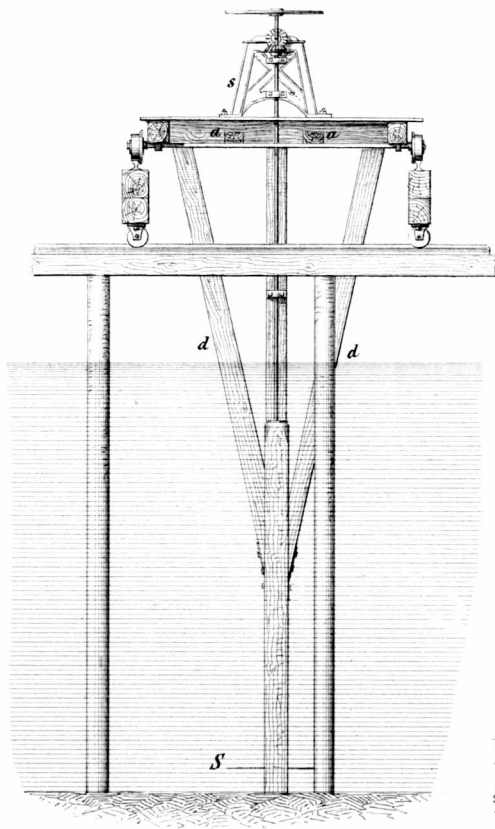

242.a

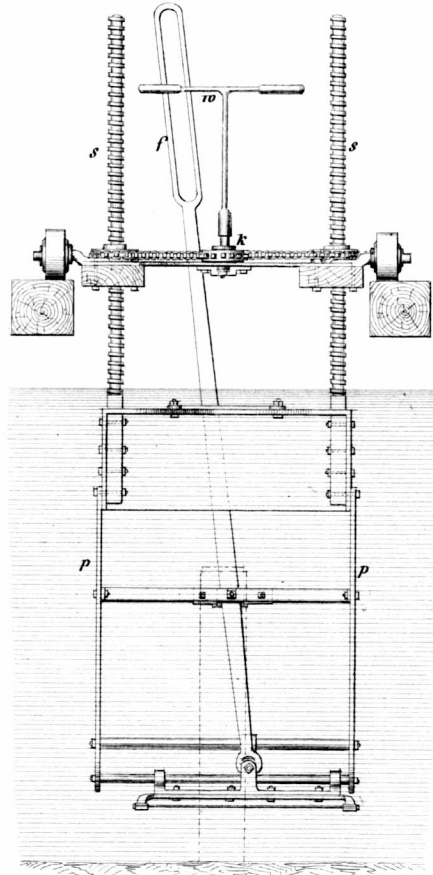

236

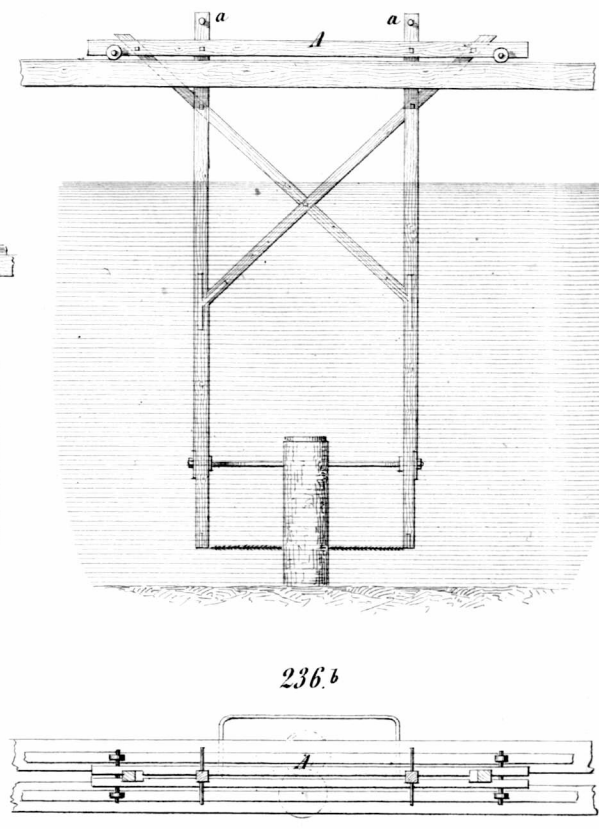

236.b



236.a

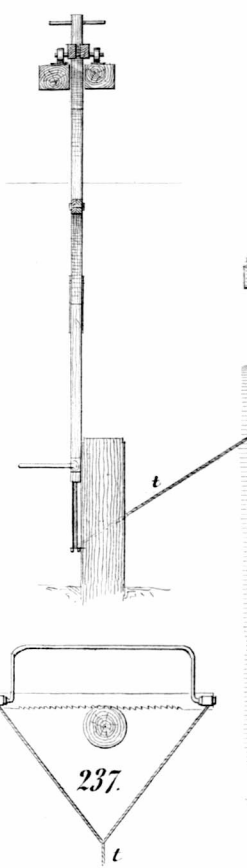

237

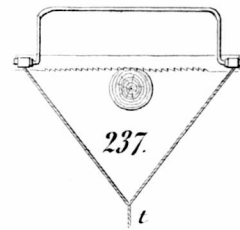

239.a

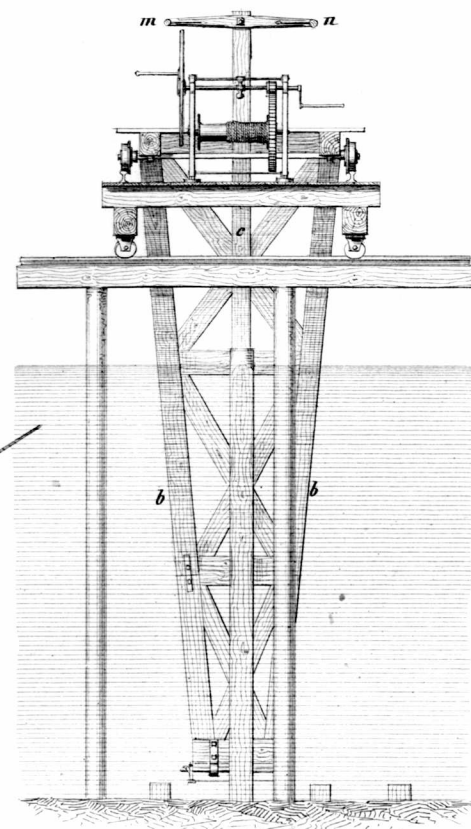

242.b

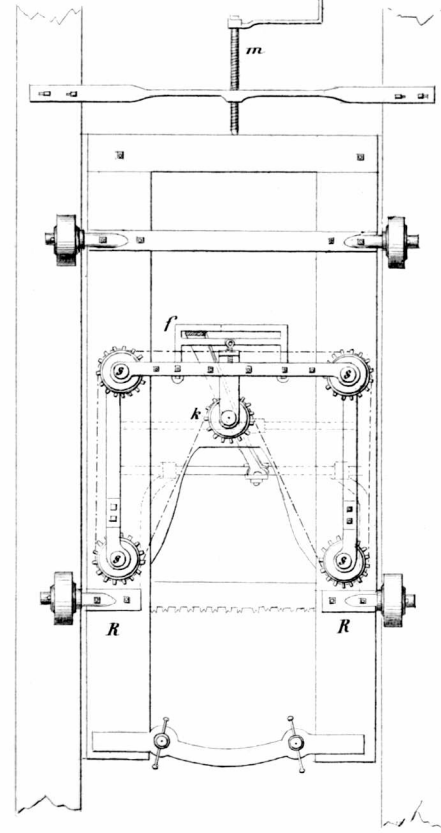

239

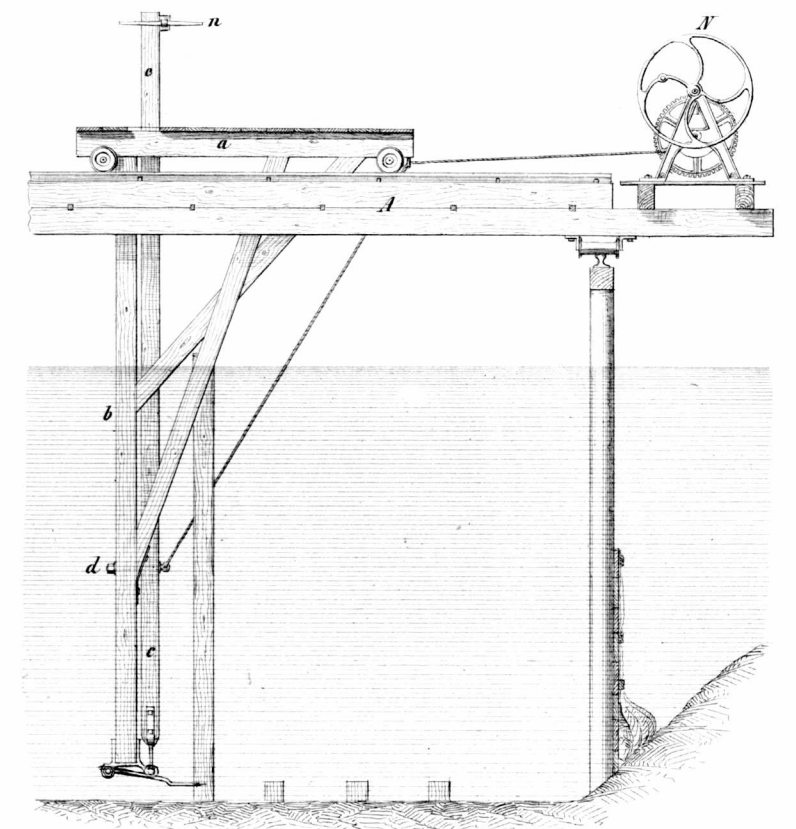

239.b

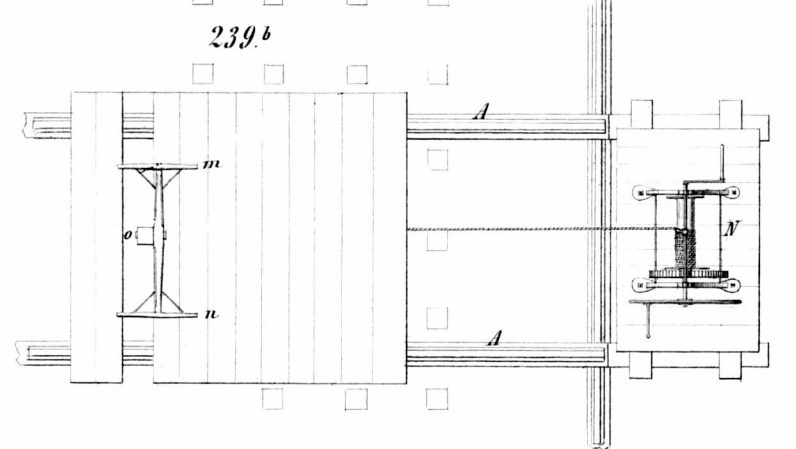

235

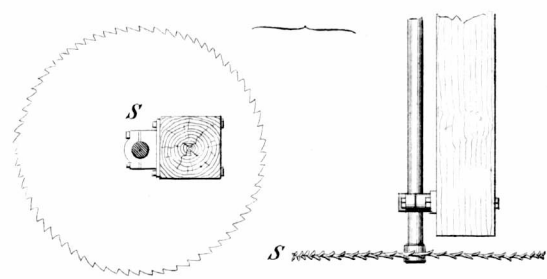

243



238

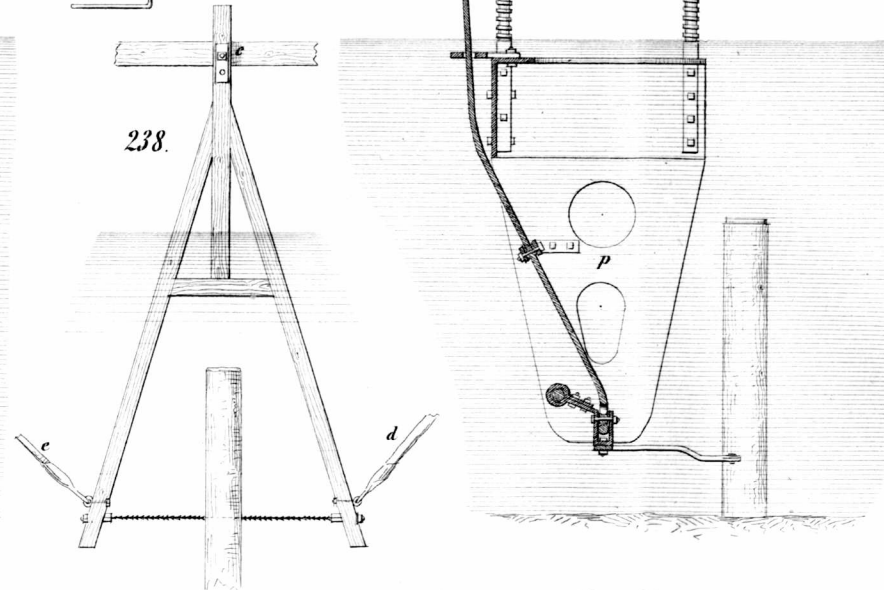

zu 234, 239.

zu 236, 238, 242.

zu 243-245.

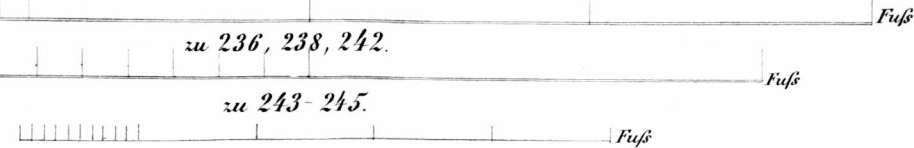

240

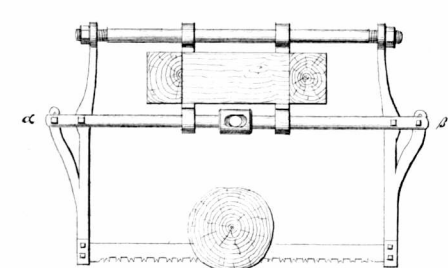

244



241

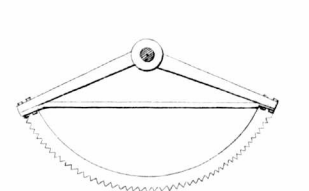

245



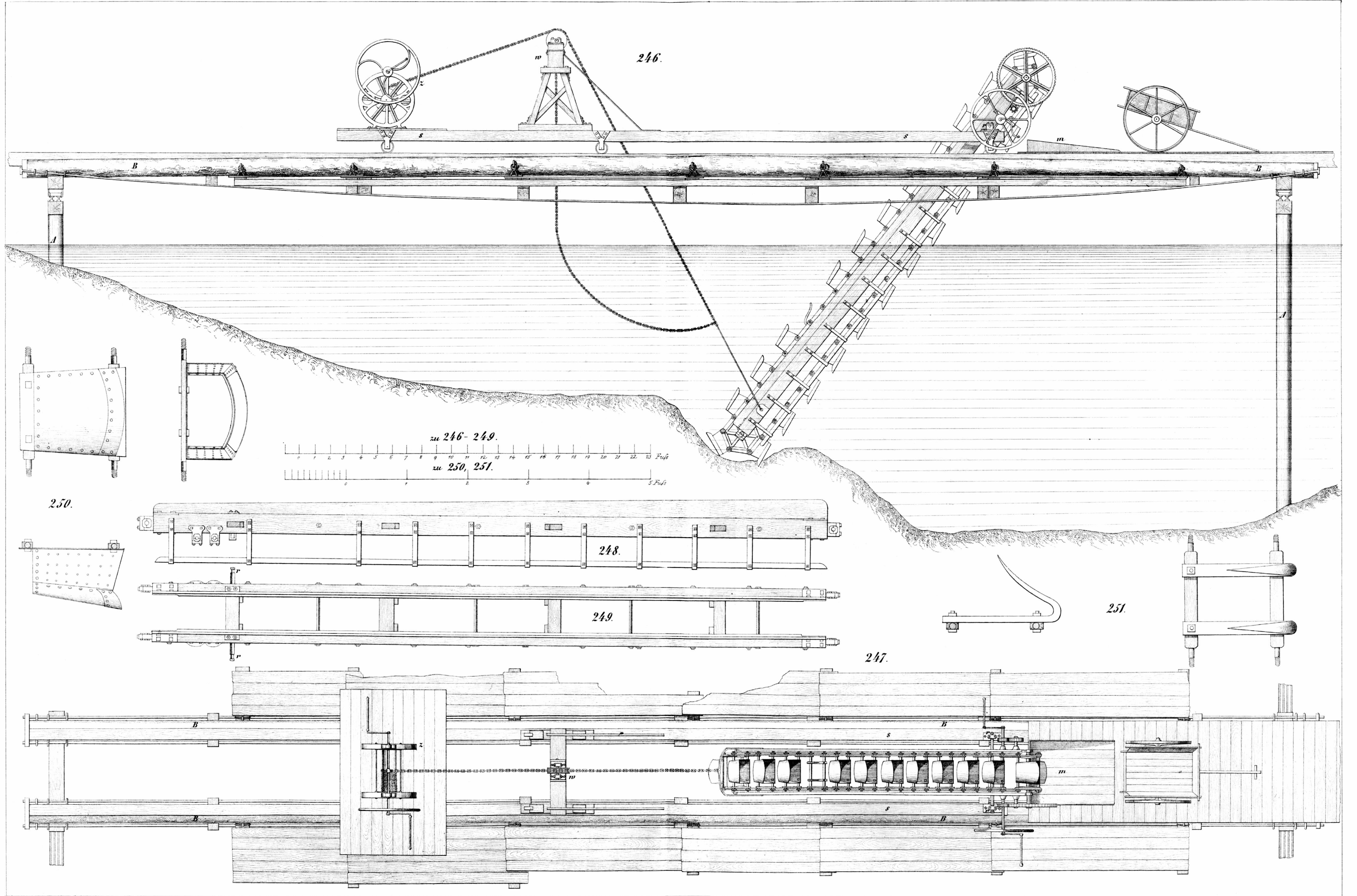

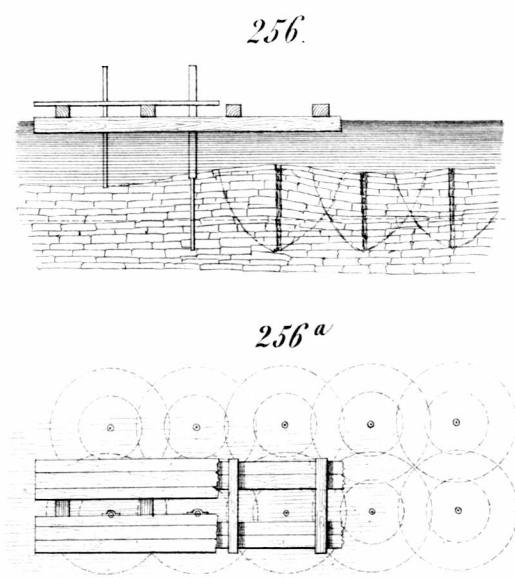
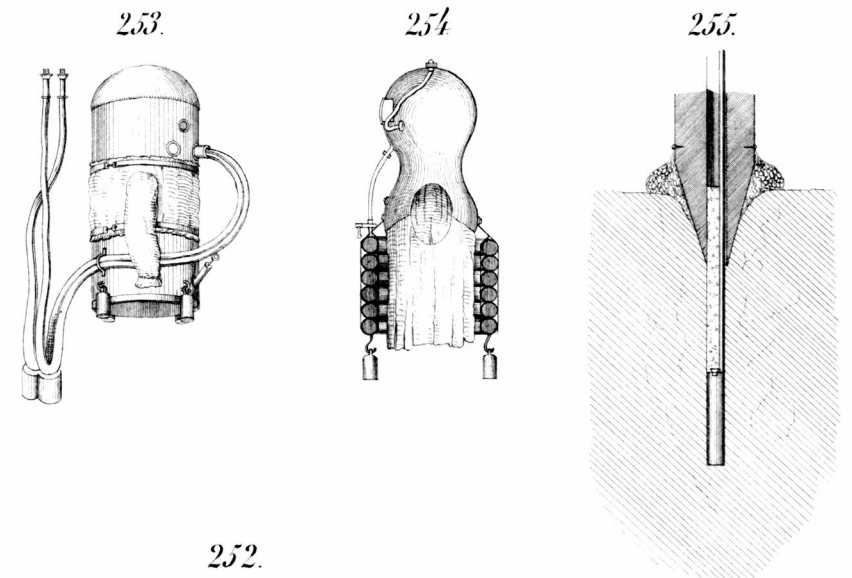

260. 259. 258. 257.

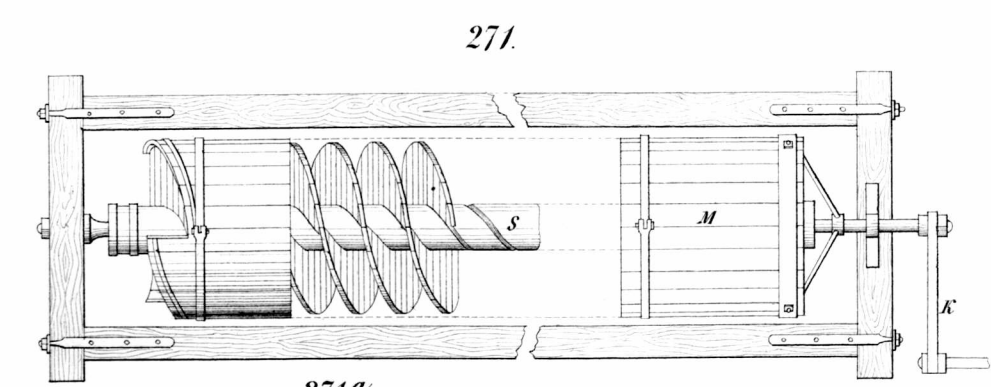
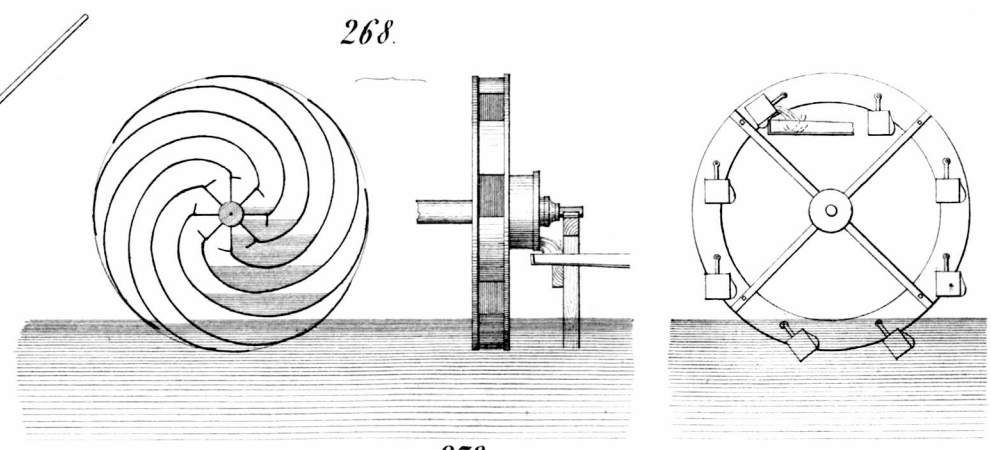
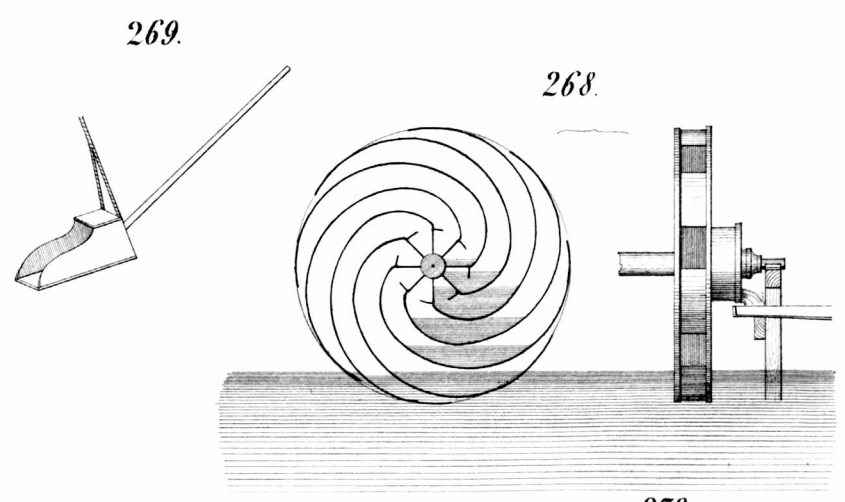
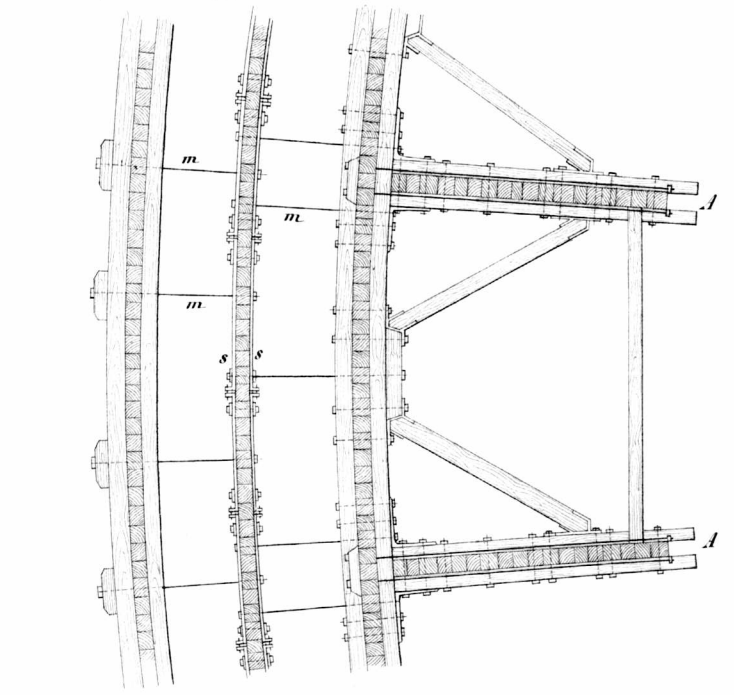
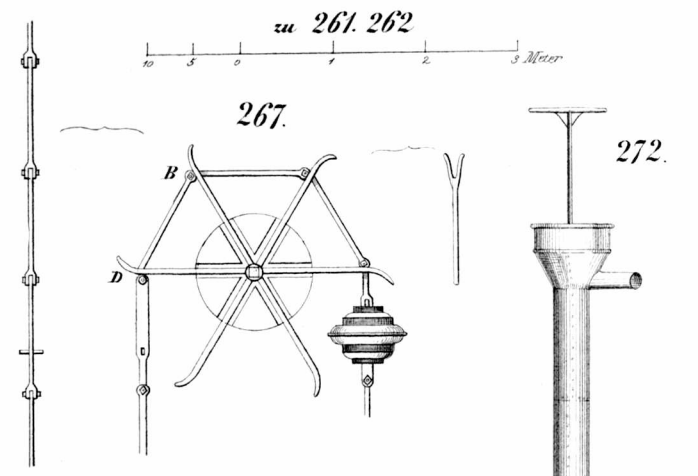
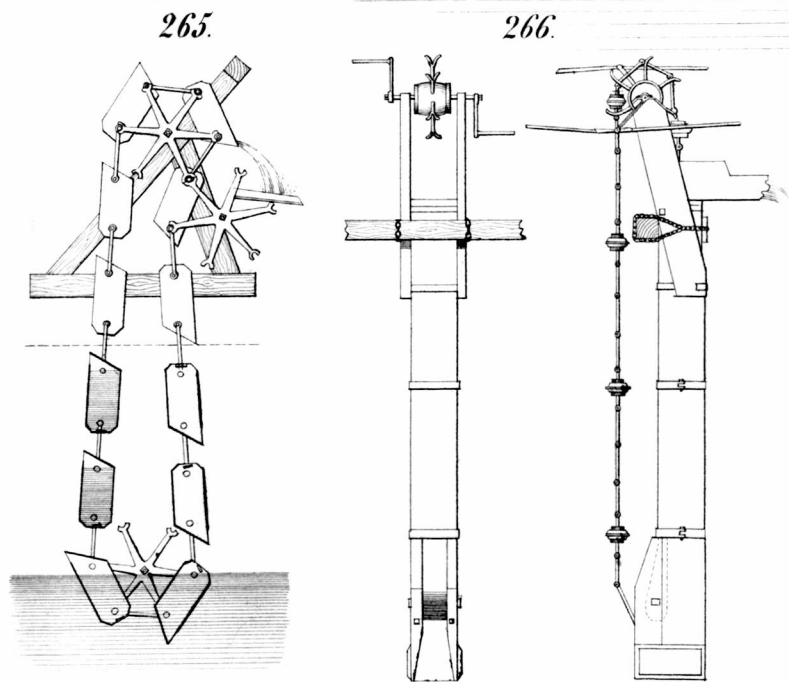
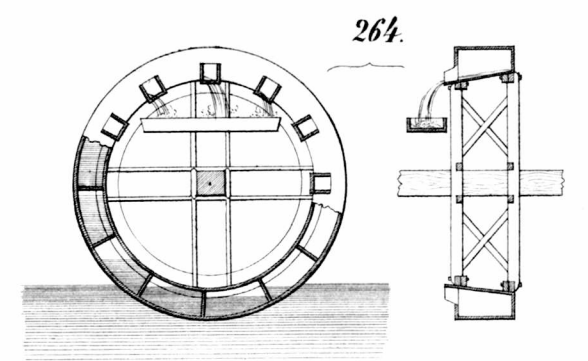
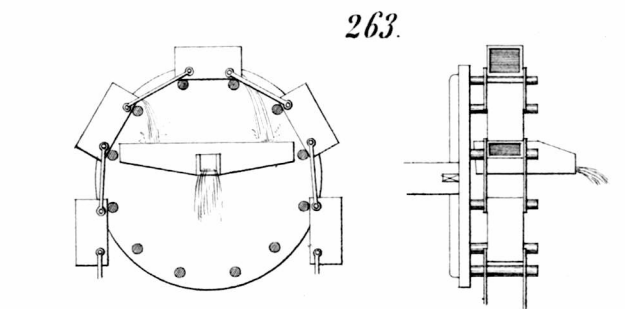
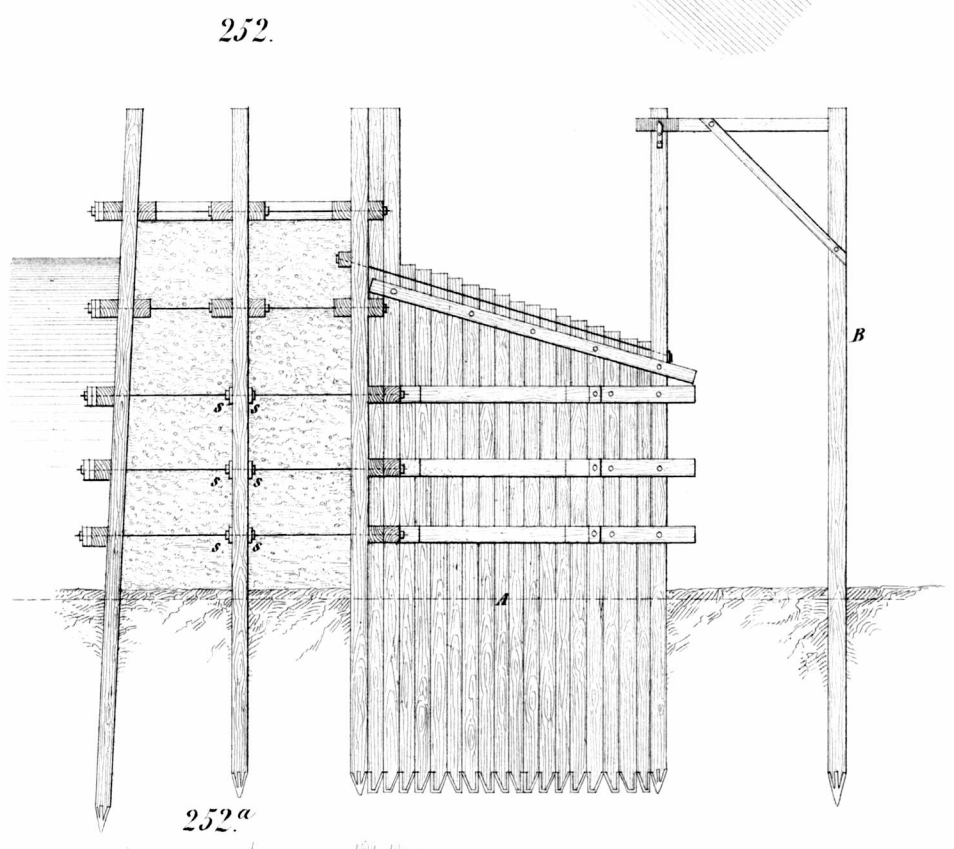
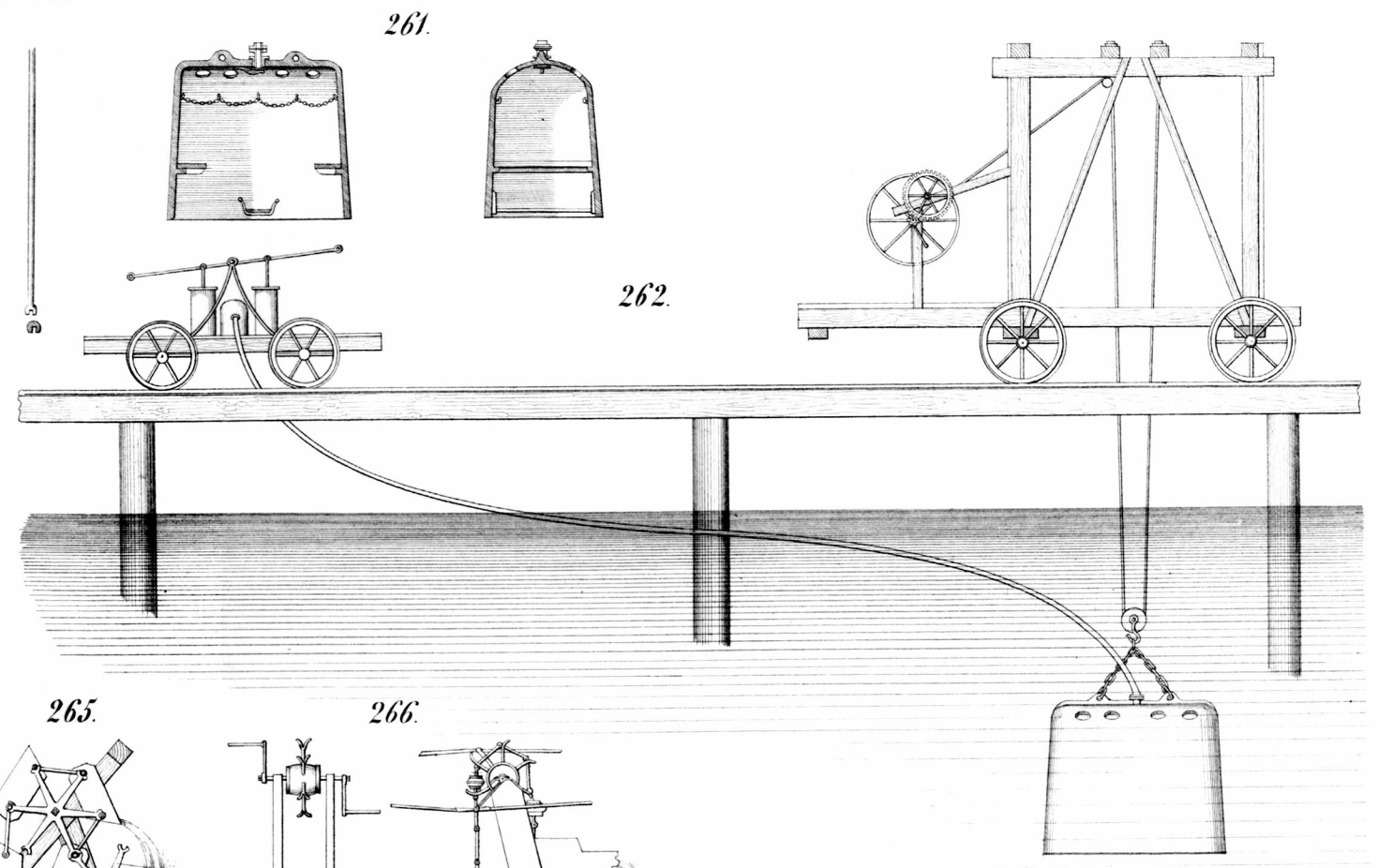
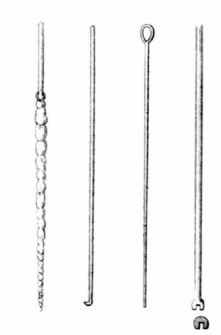

zu 252. 252^a
5 Meter

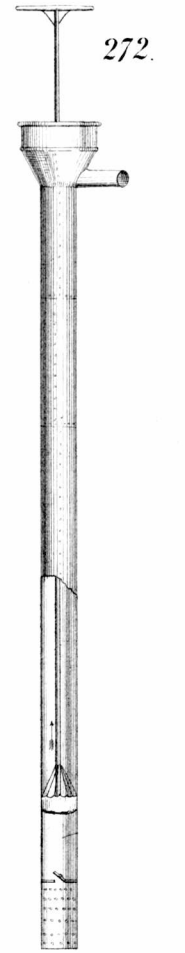
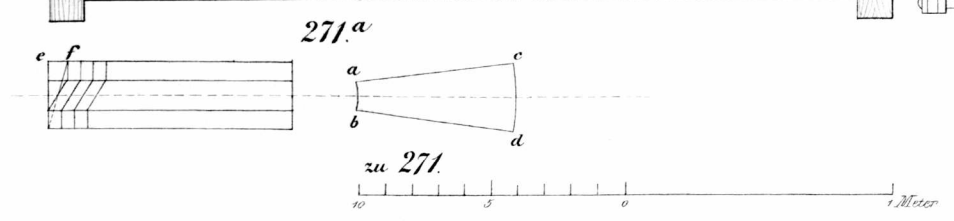
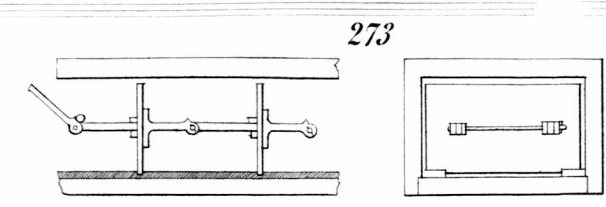

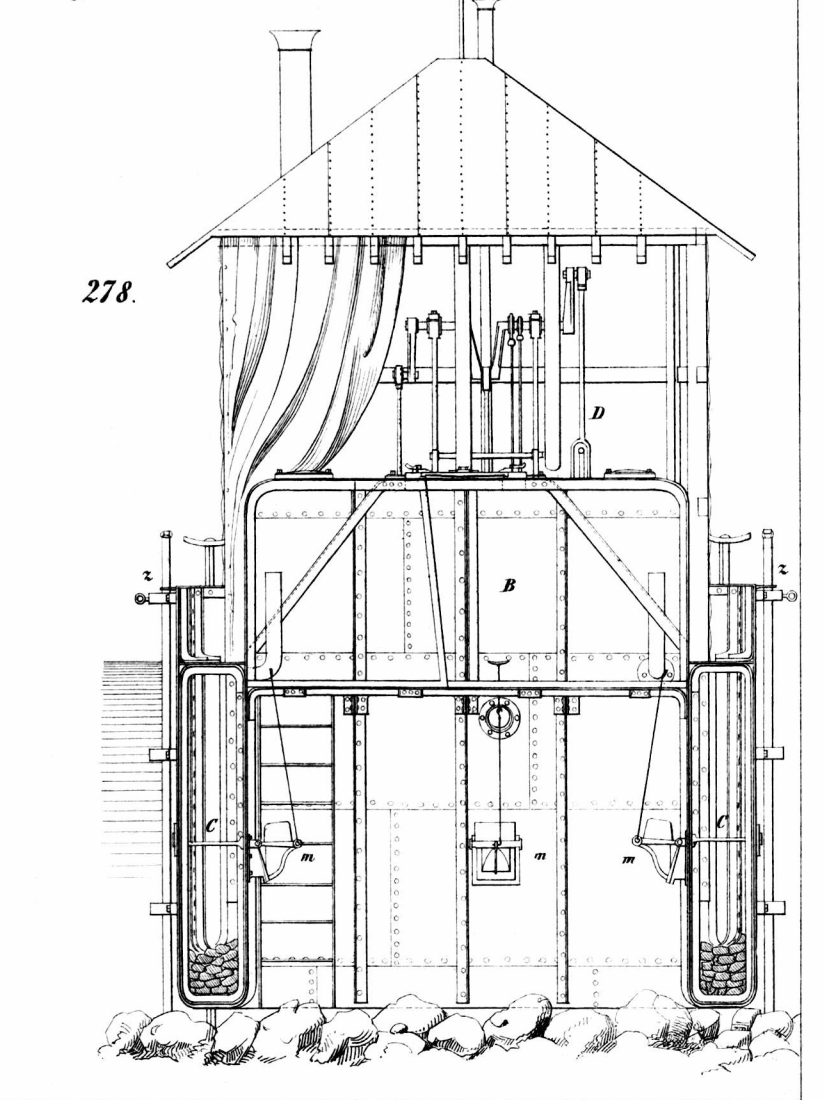
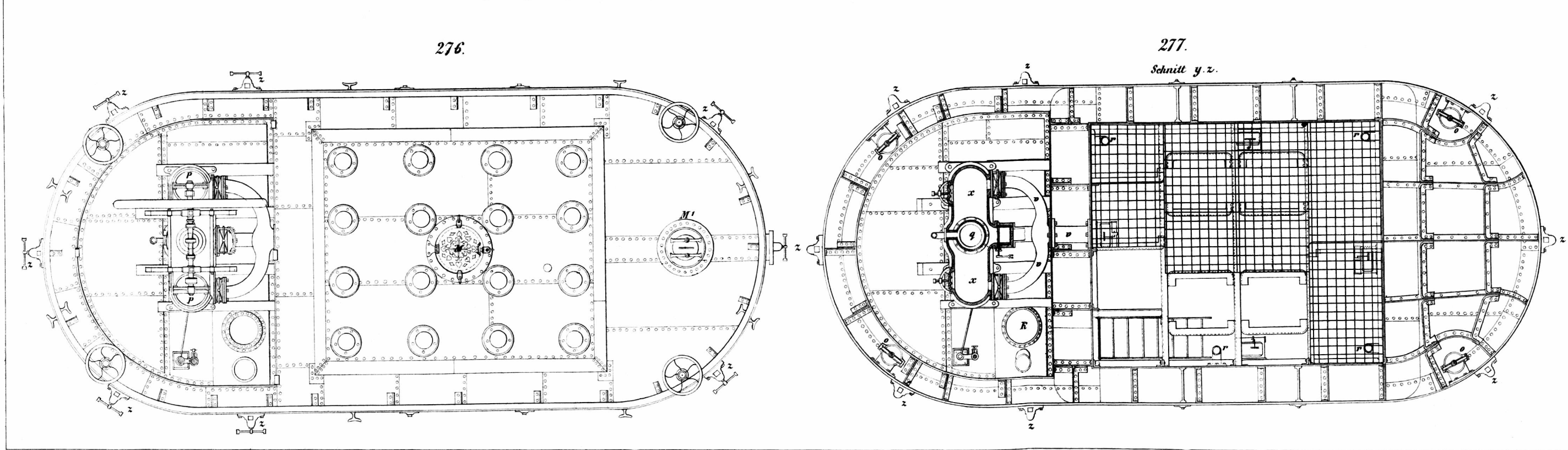
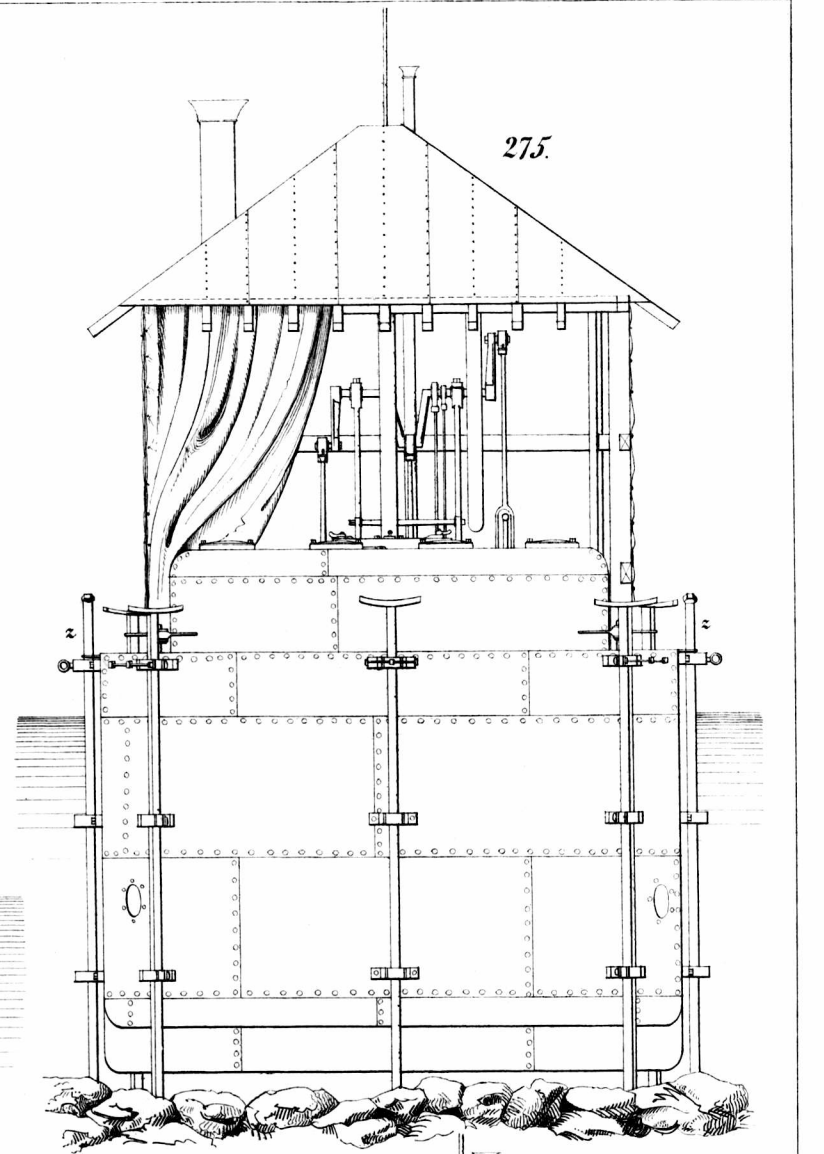
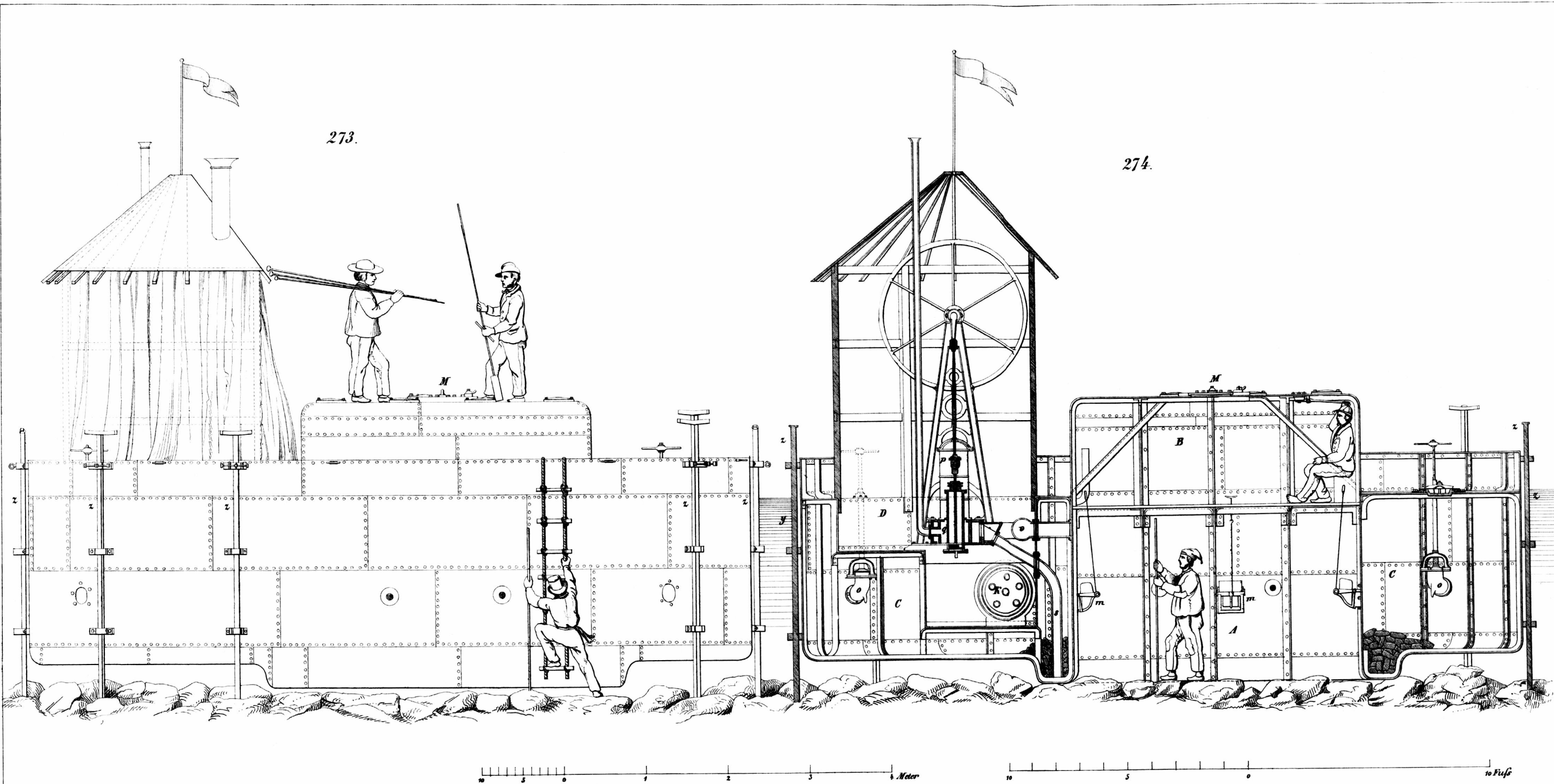

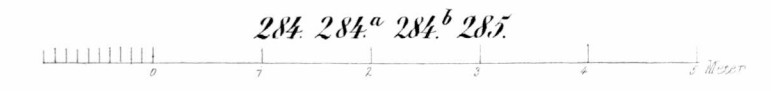
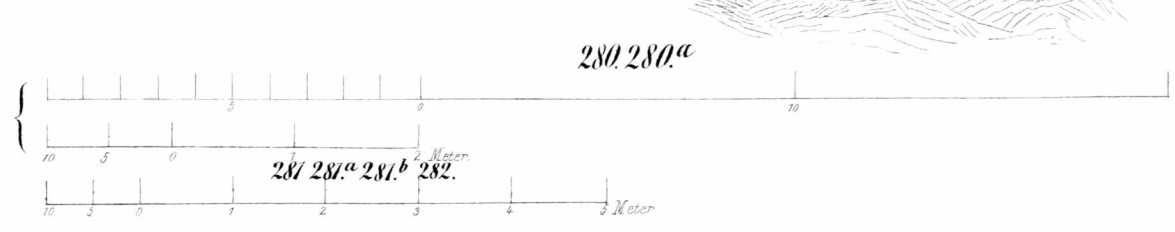
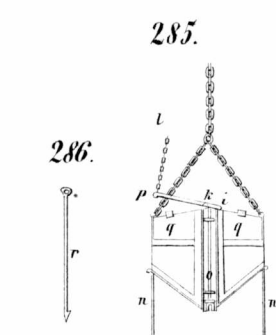
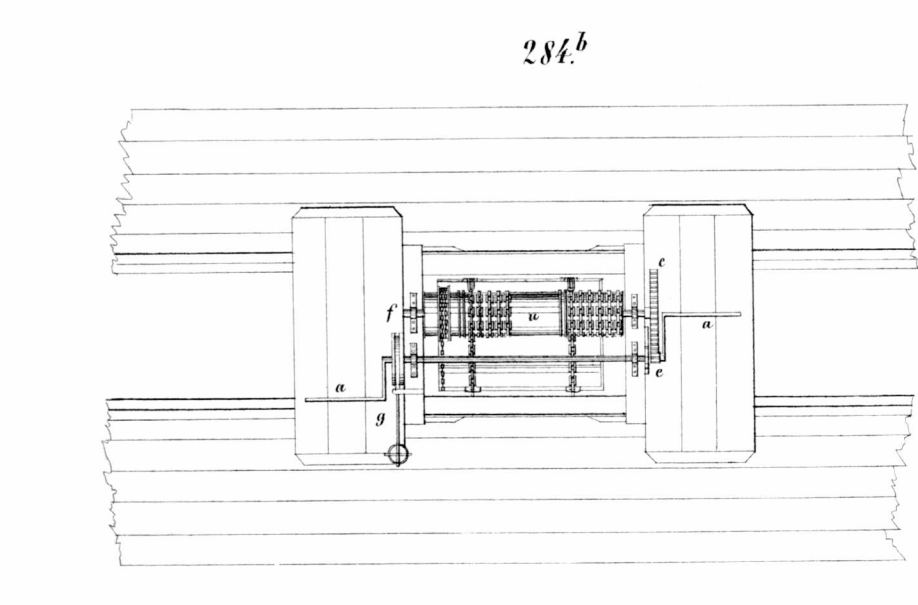
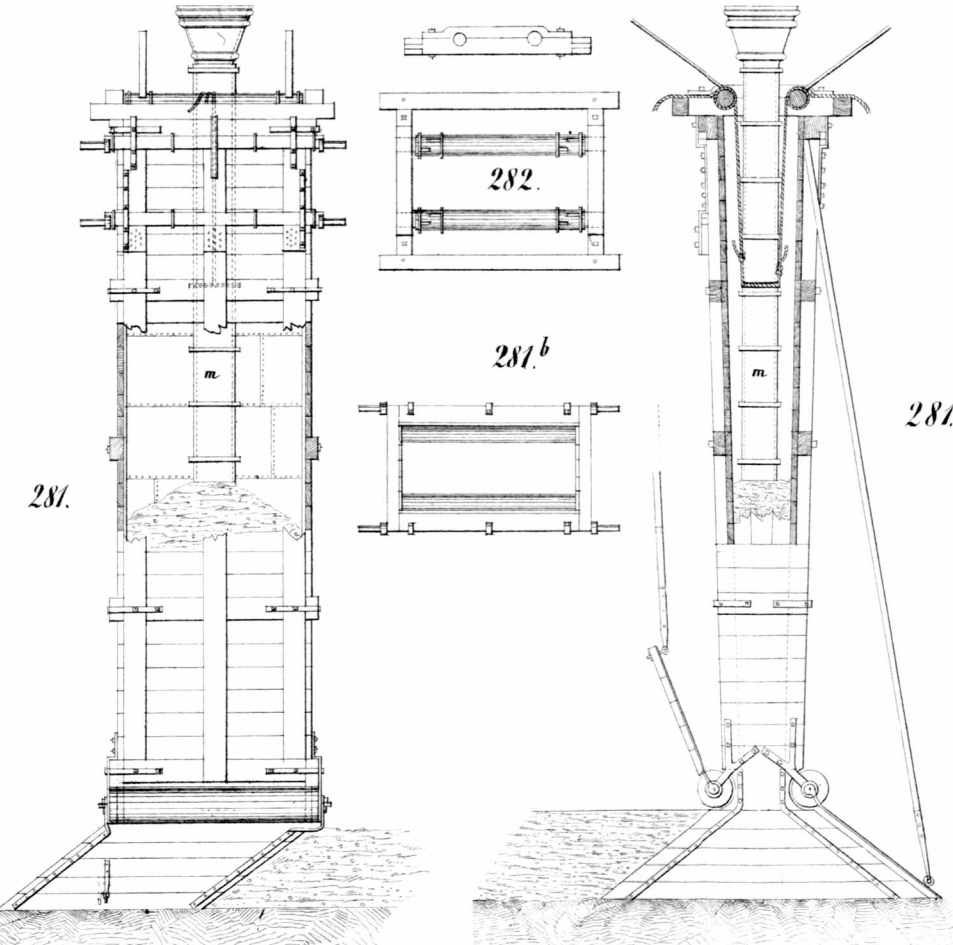
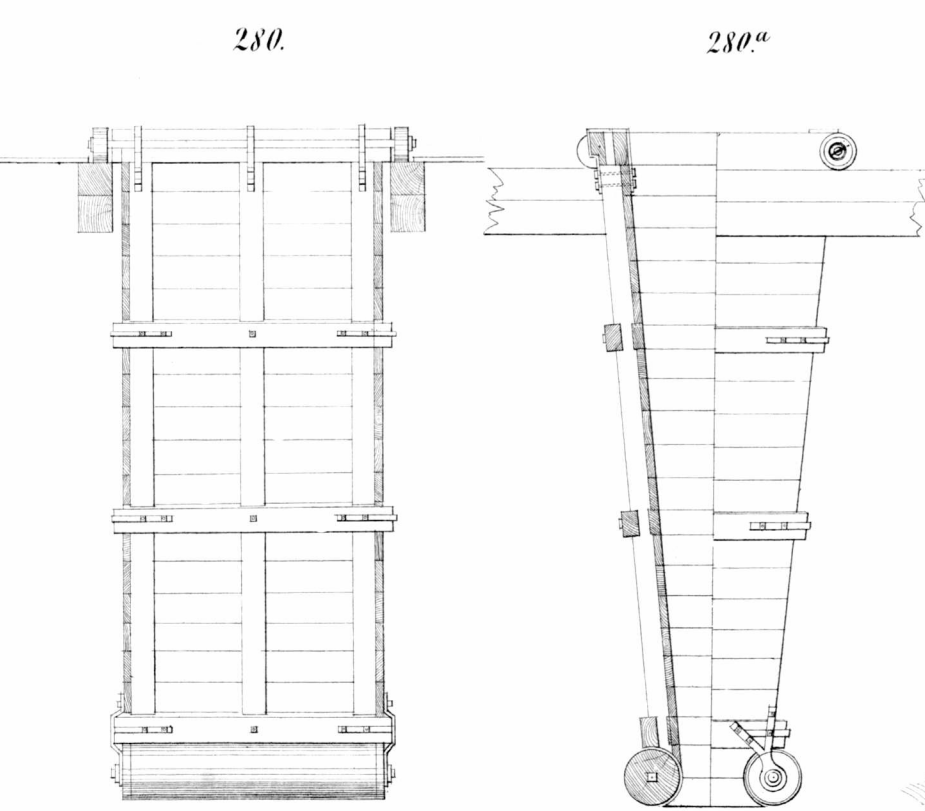
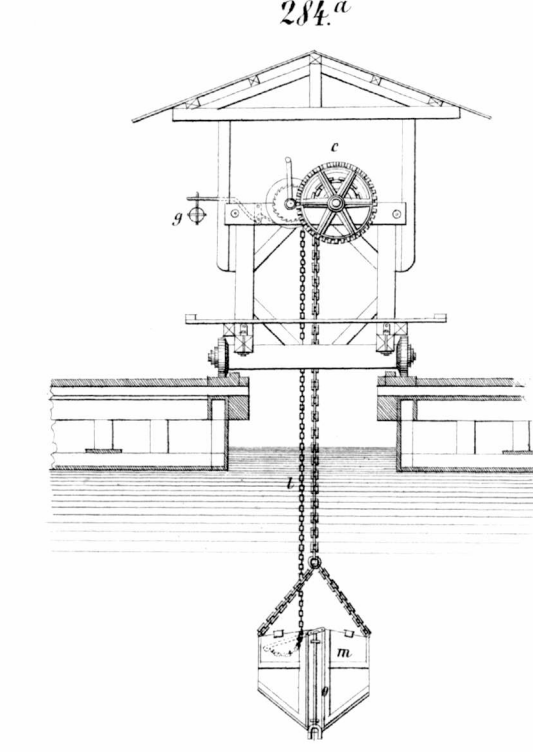
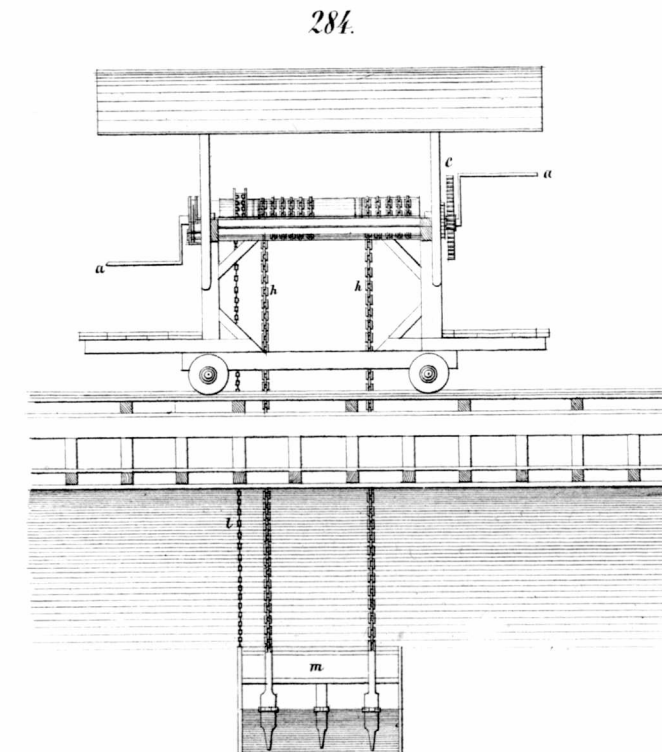
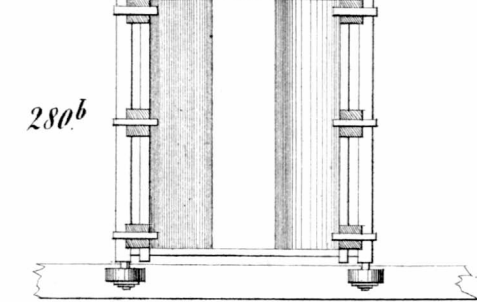
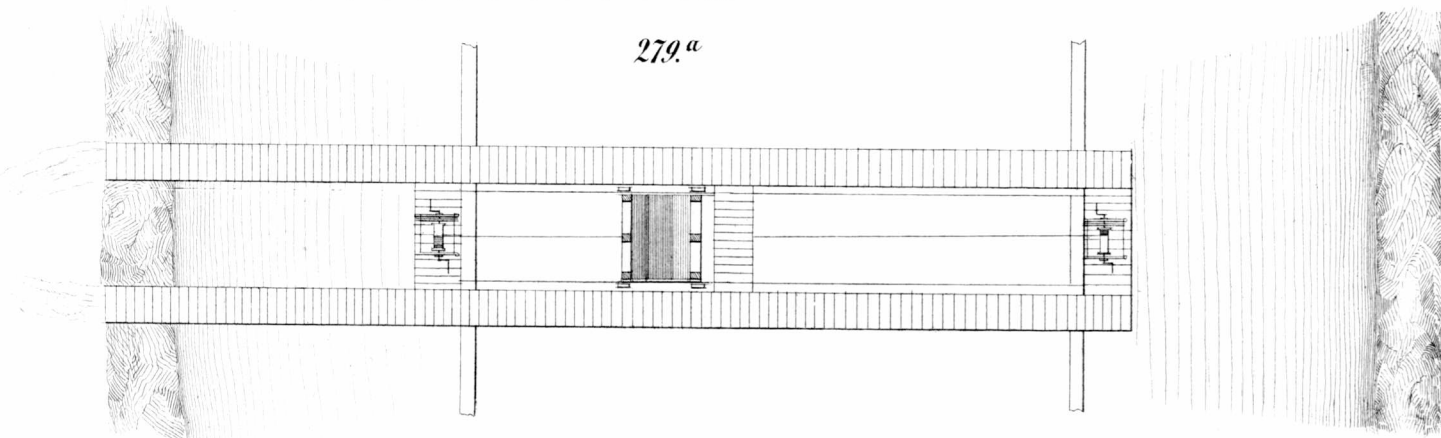
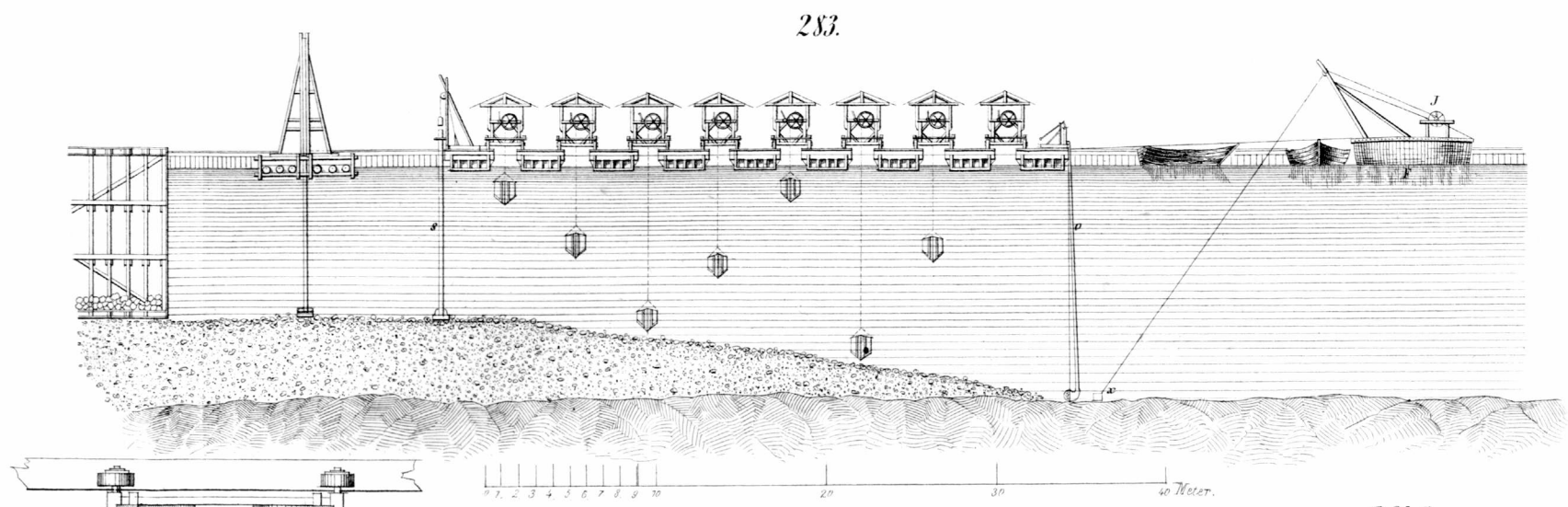
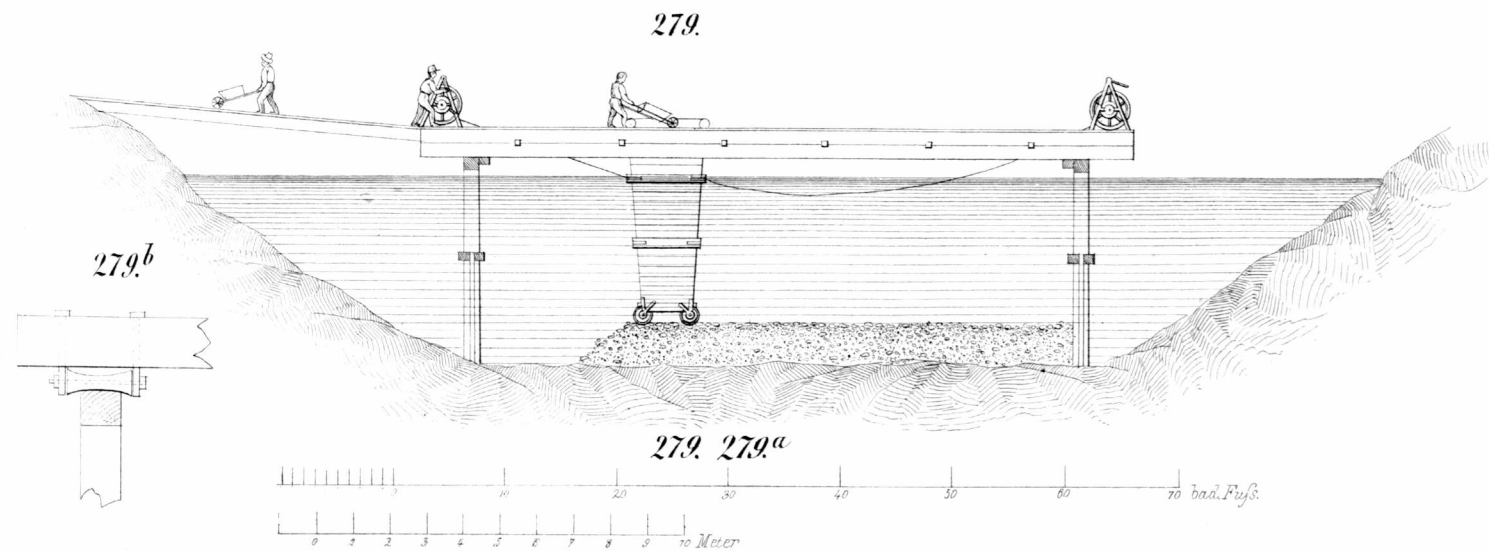

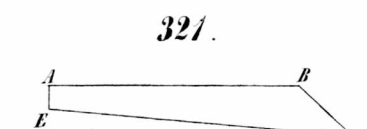
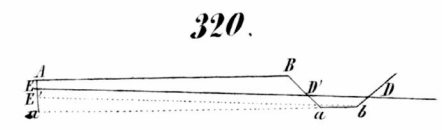
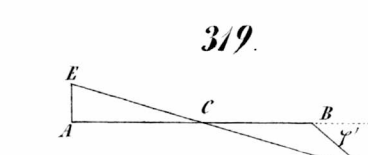
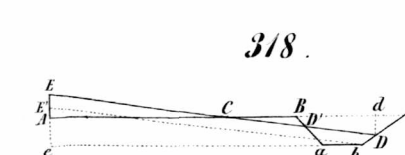
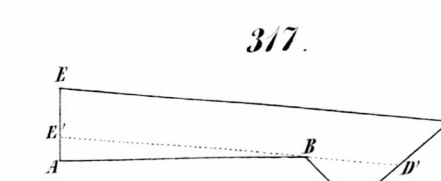
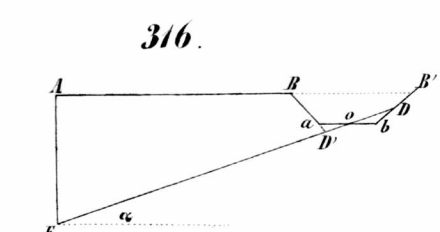
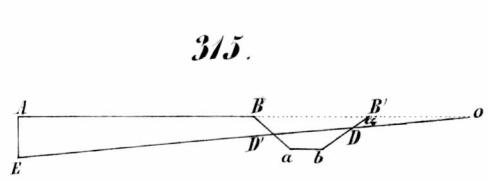
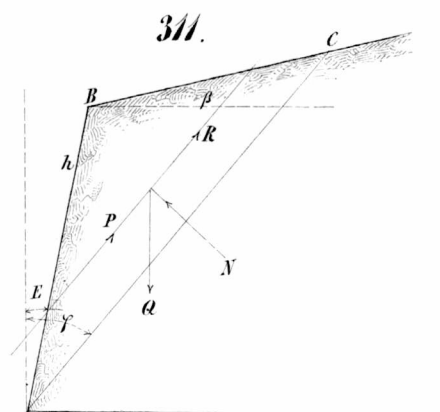
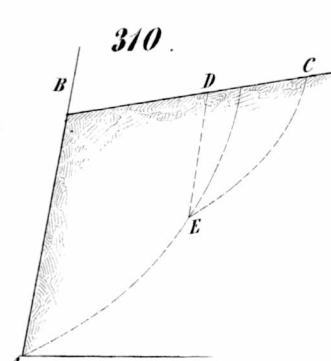
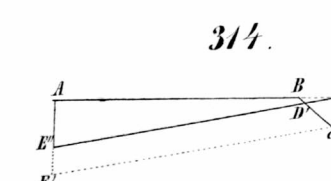
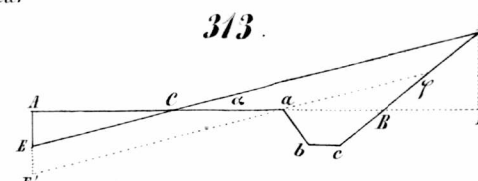
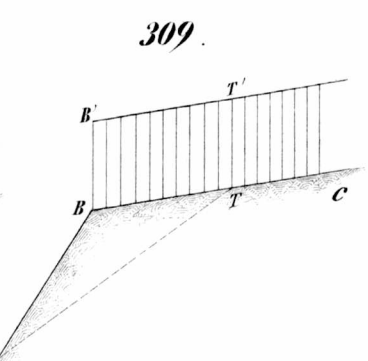
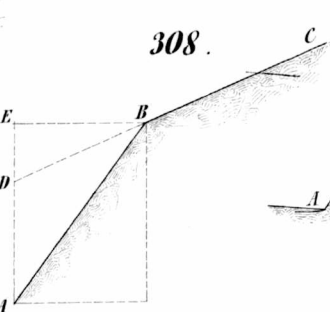
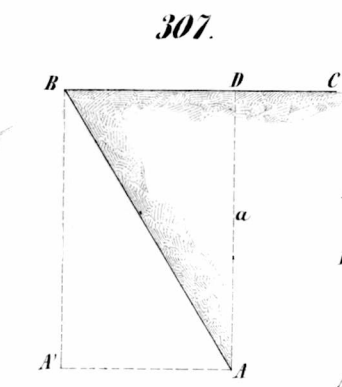
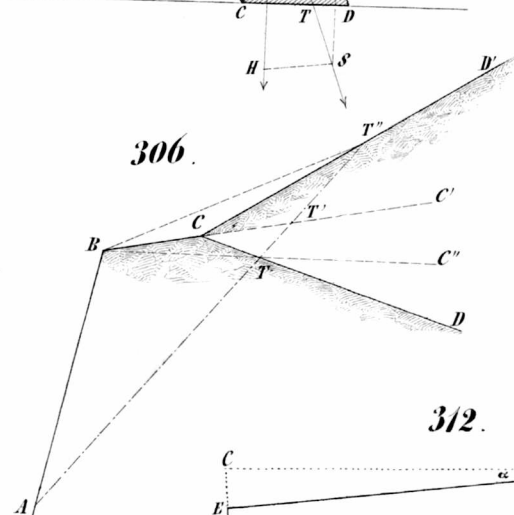
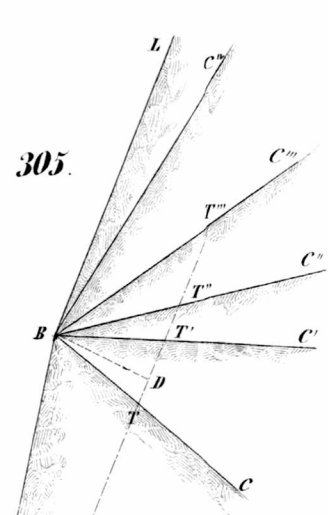
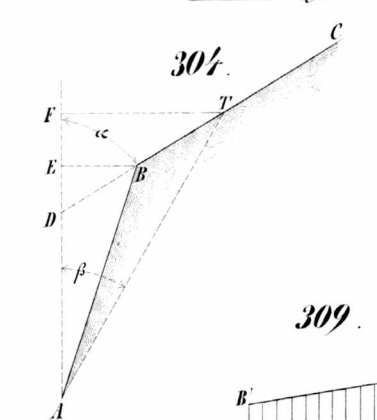
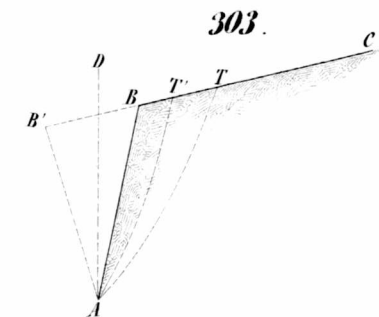
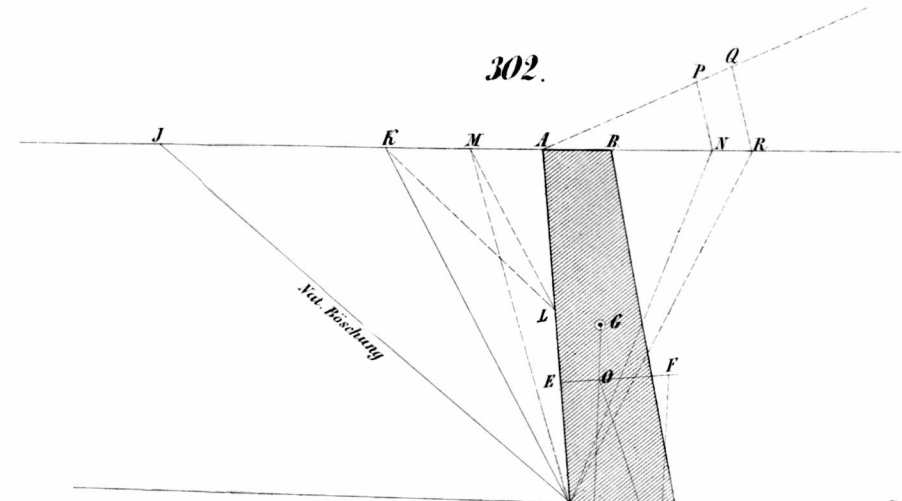
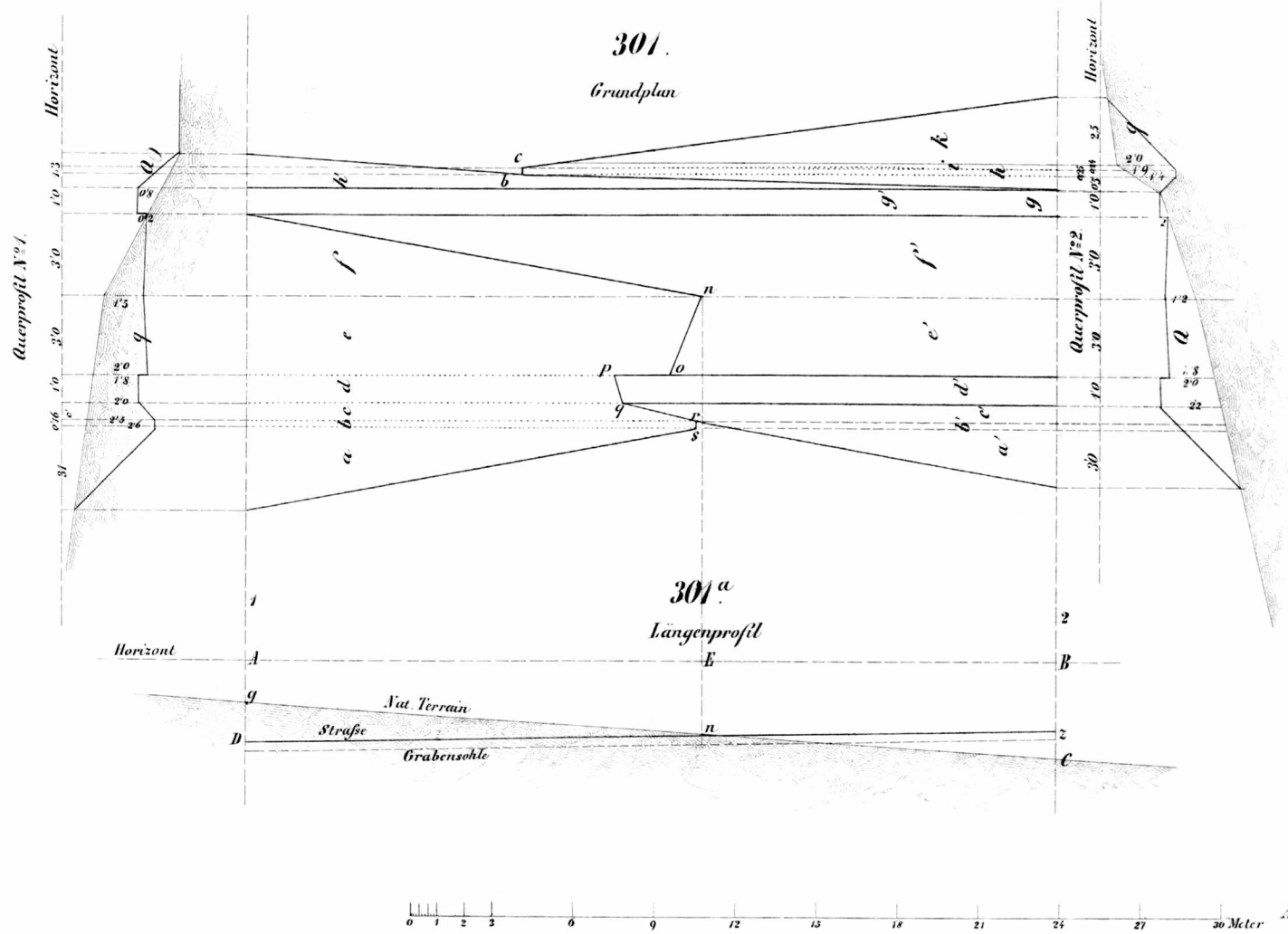
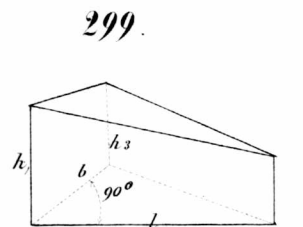
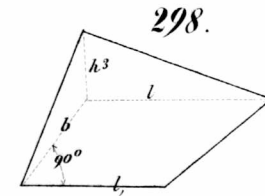
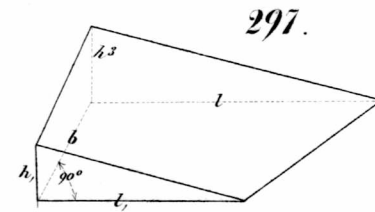
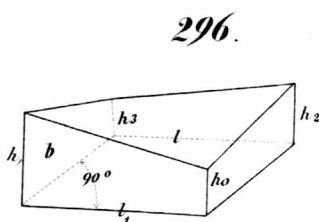
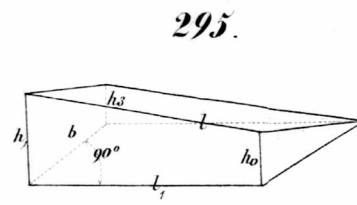
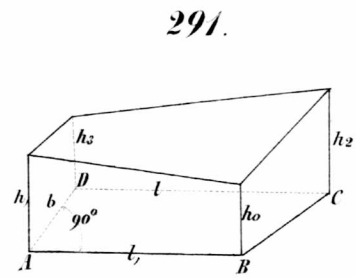
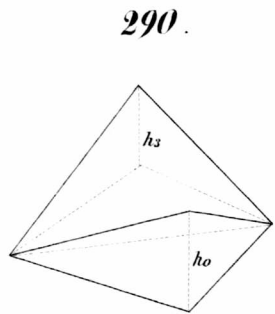
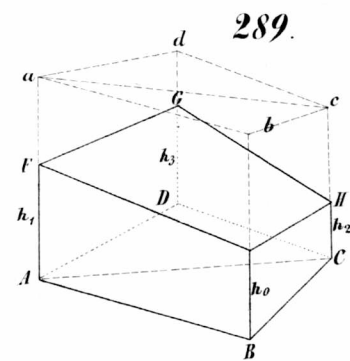
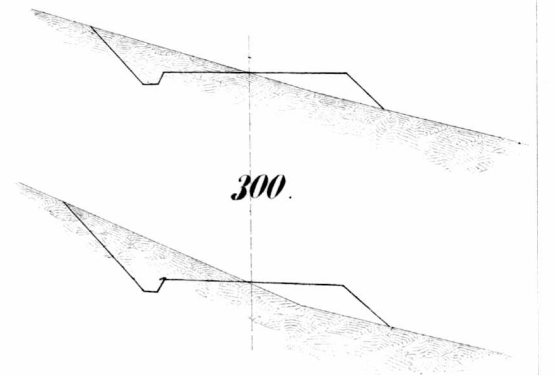
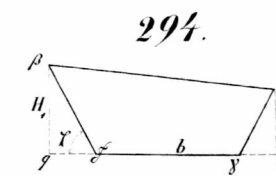
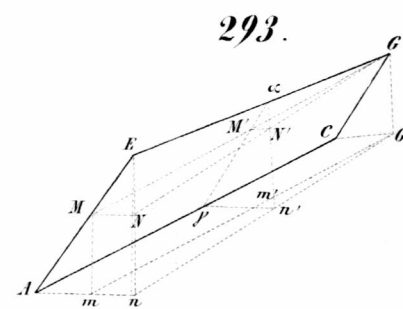
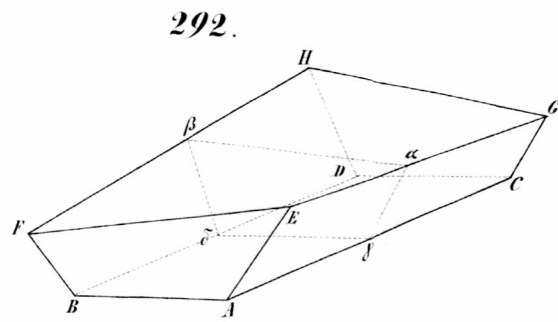
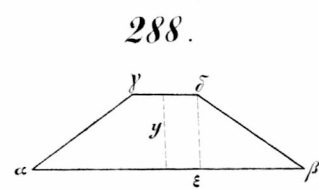
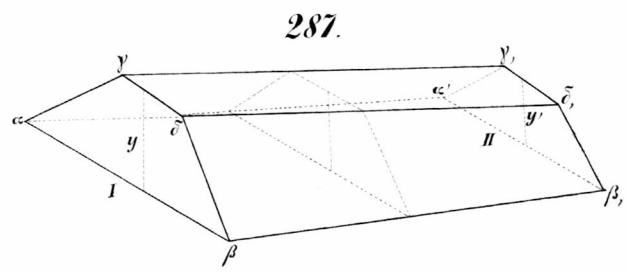

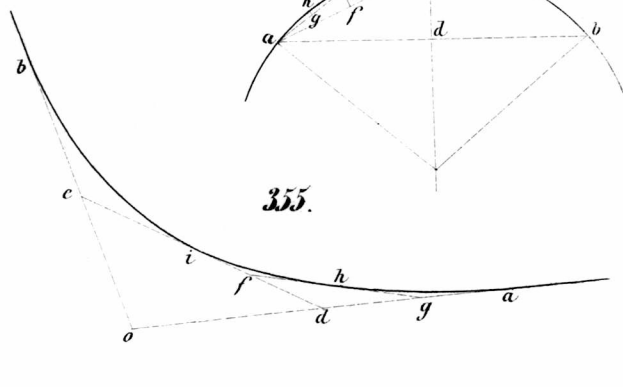
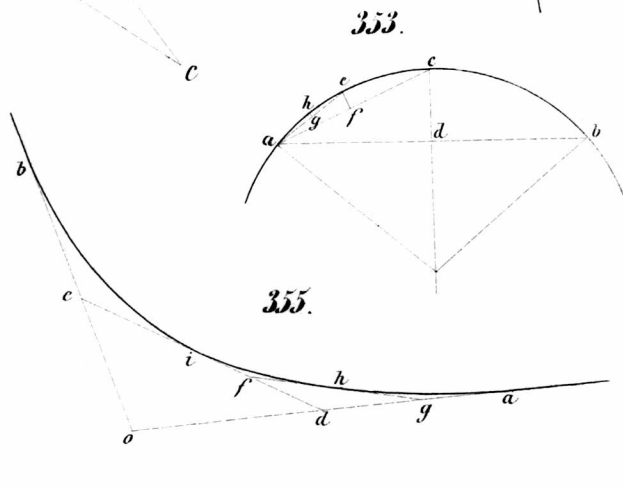
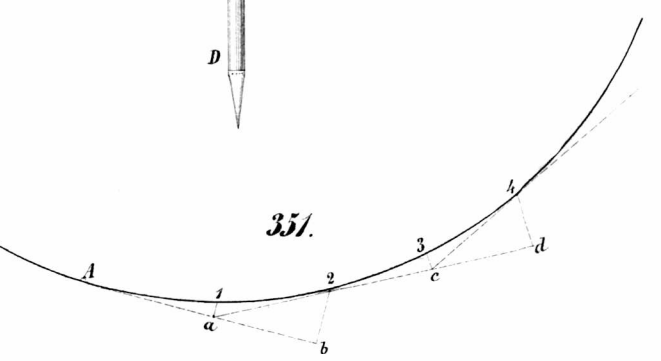
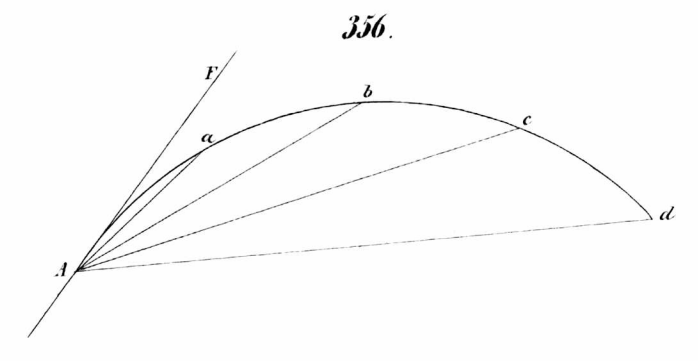
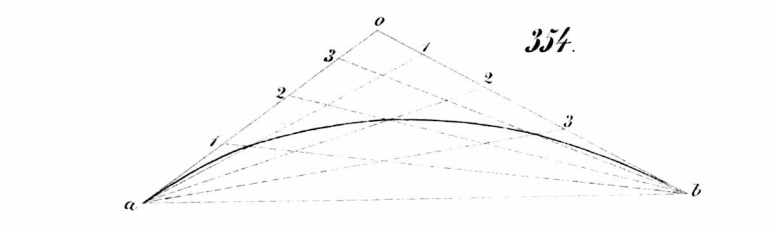
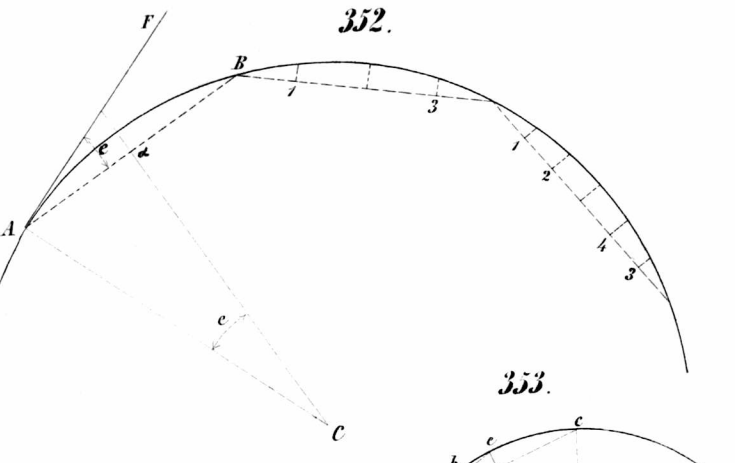
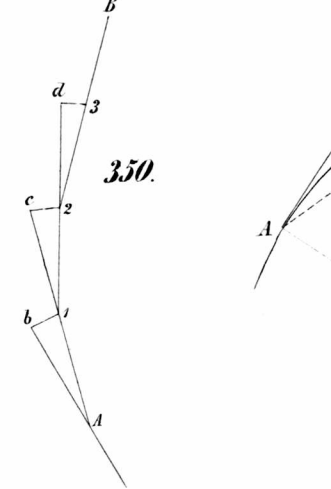
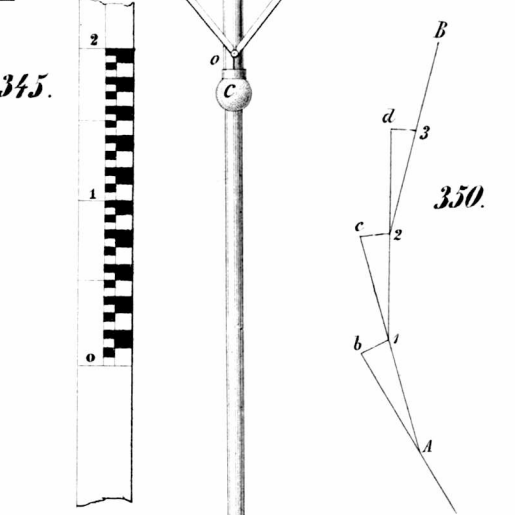
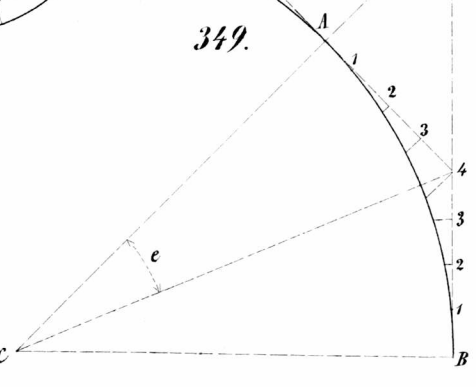
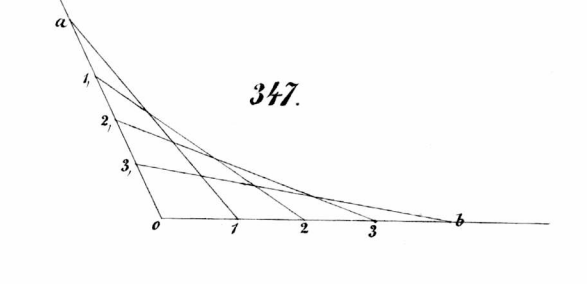
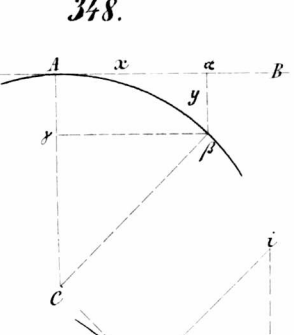
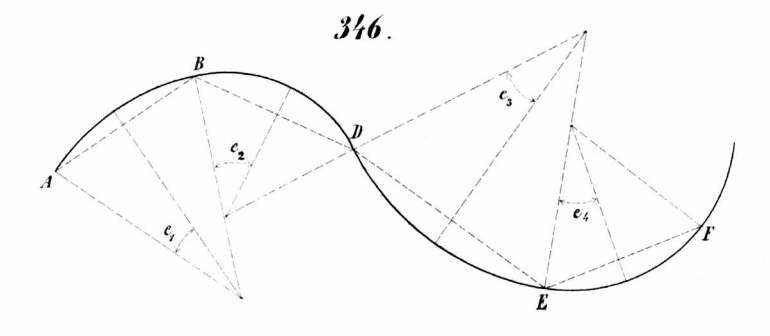
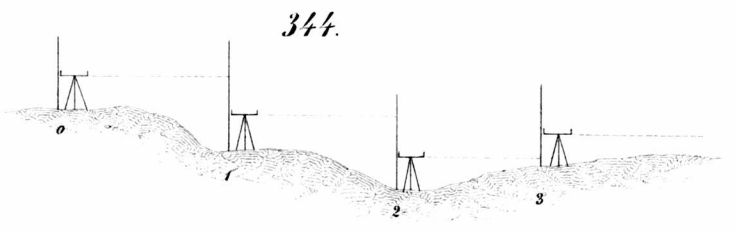
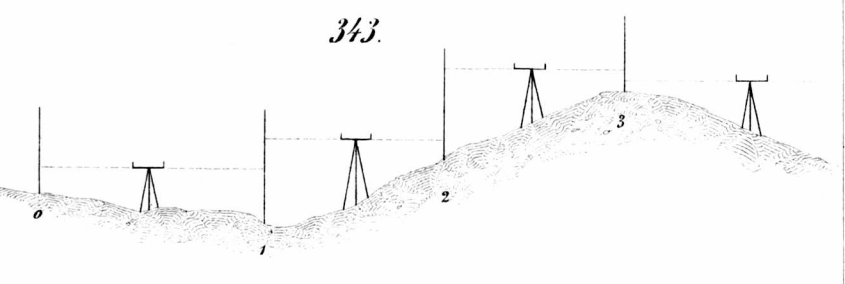
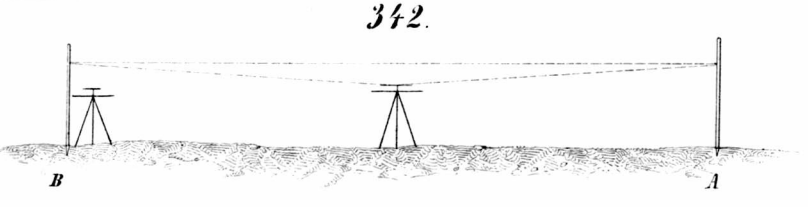
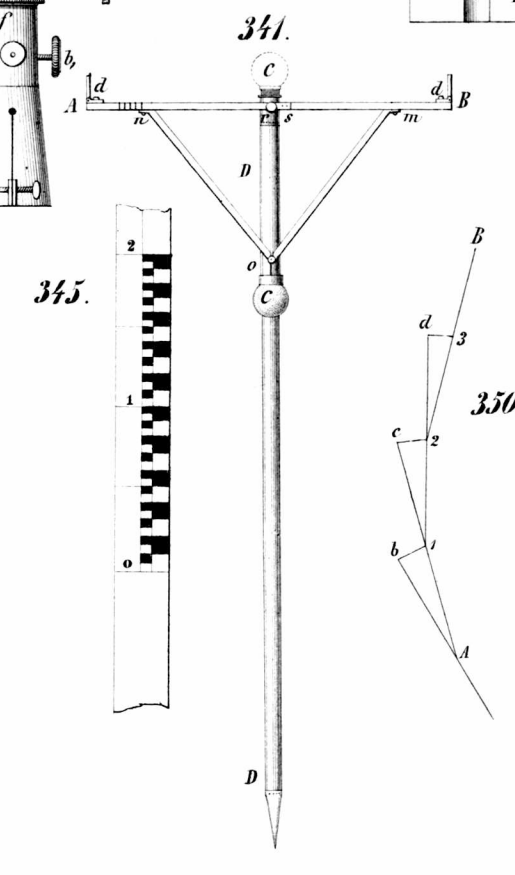
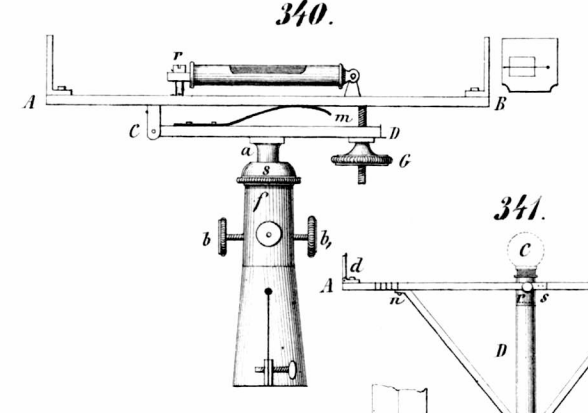
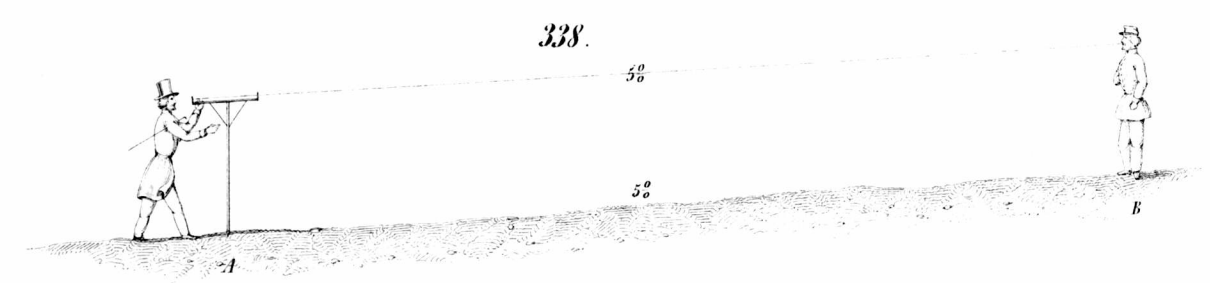
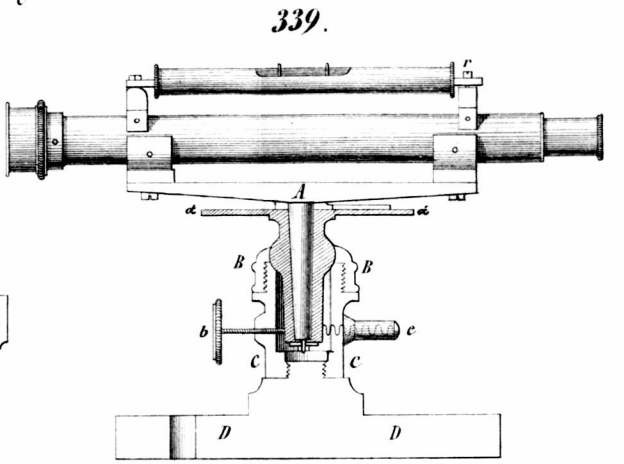
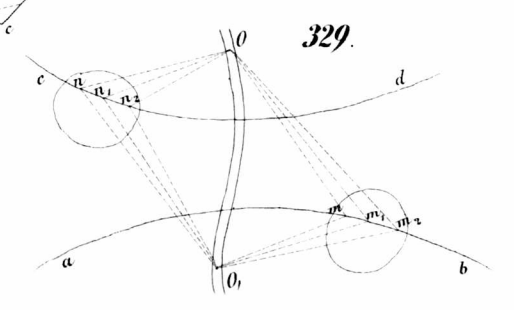
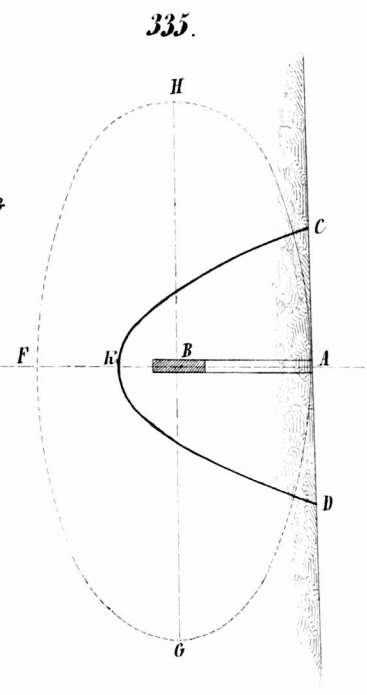
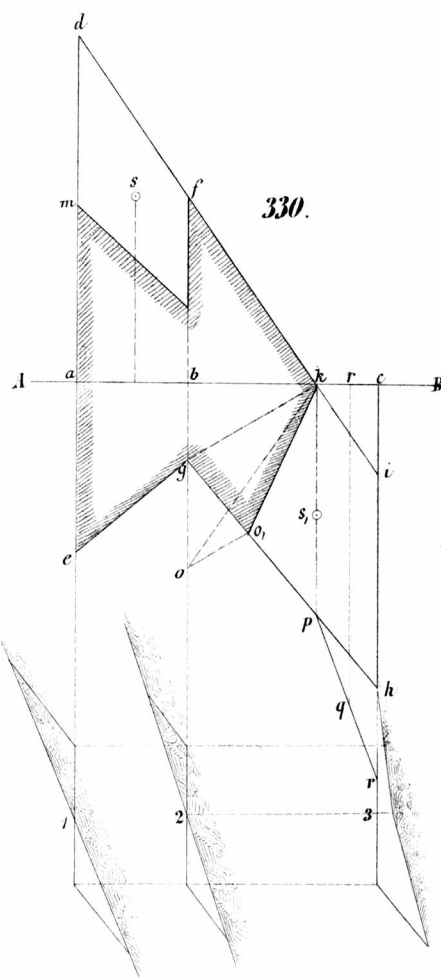
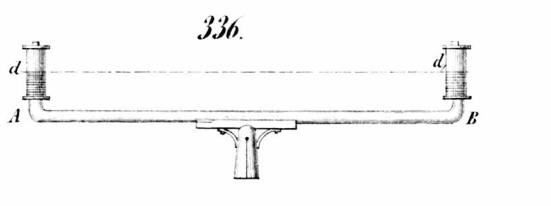
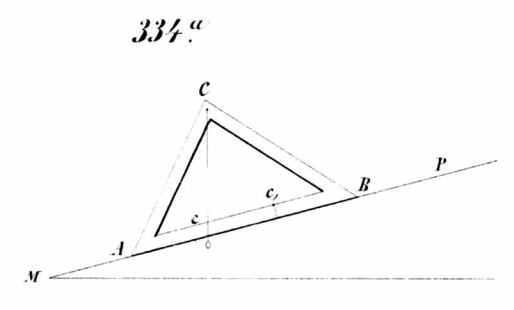
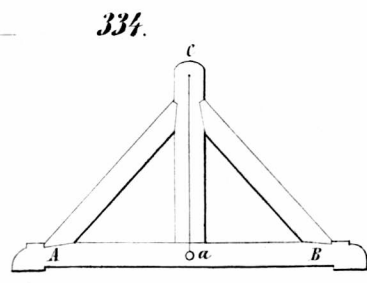
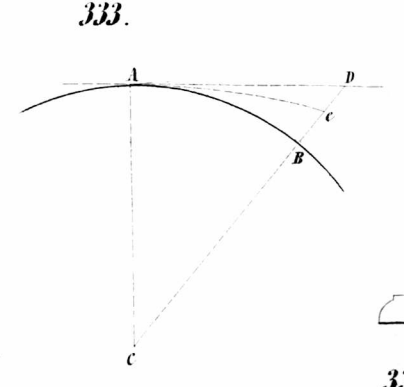
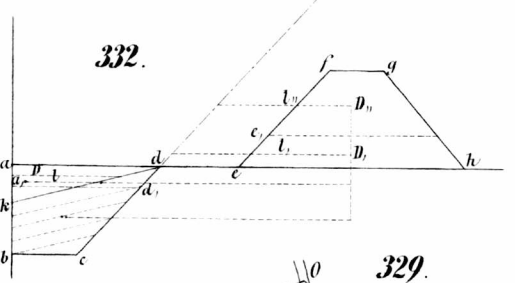
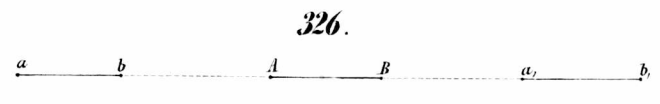
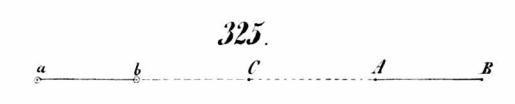
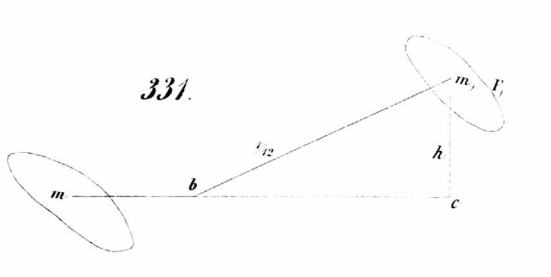
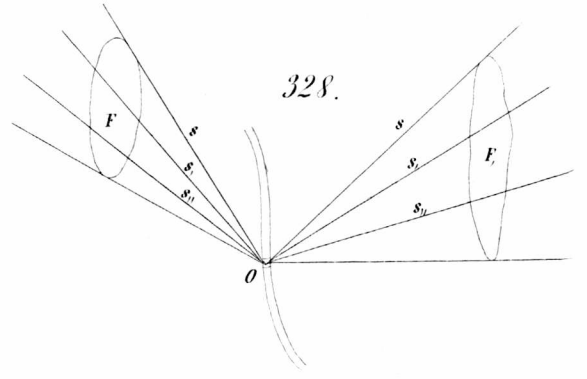
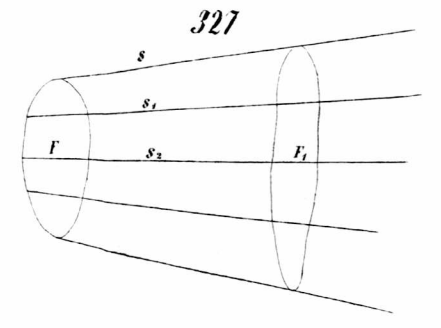
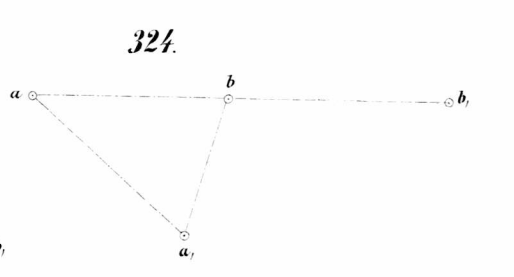
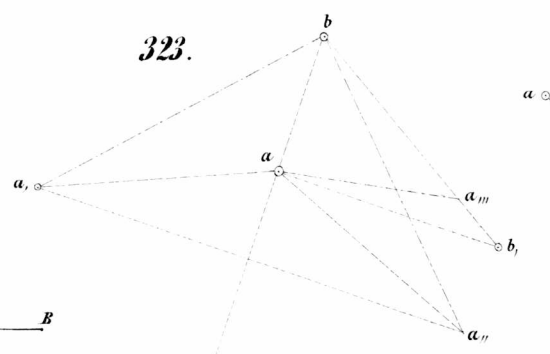
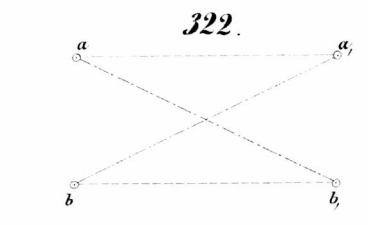

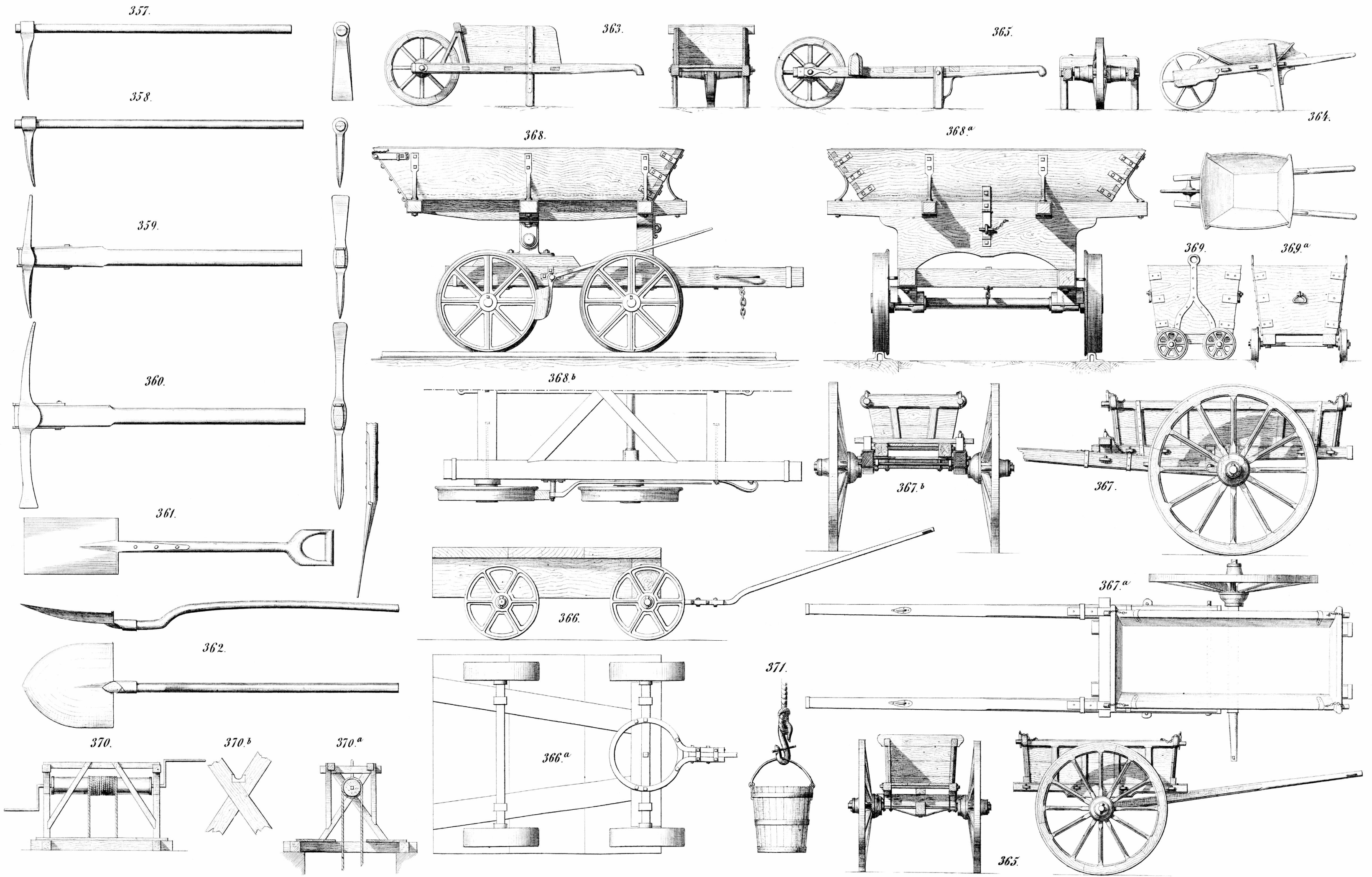

372.

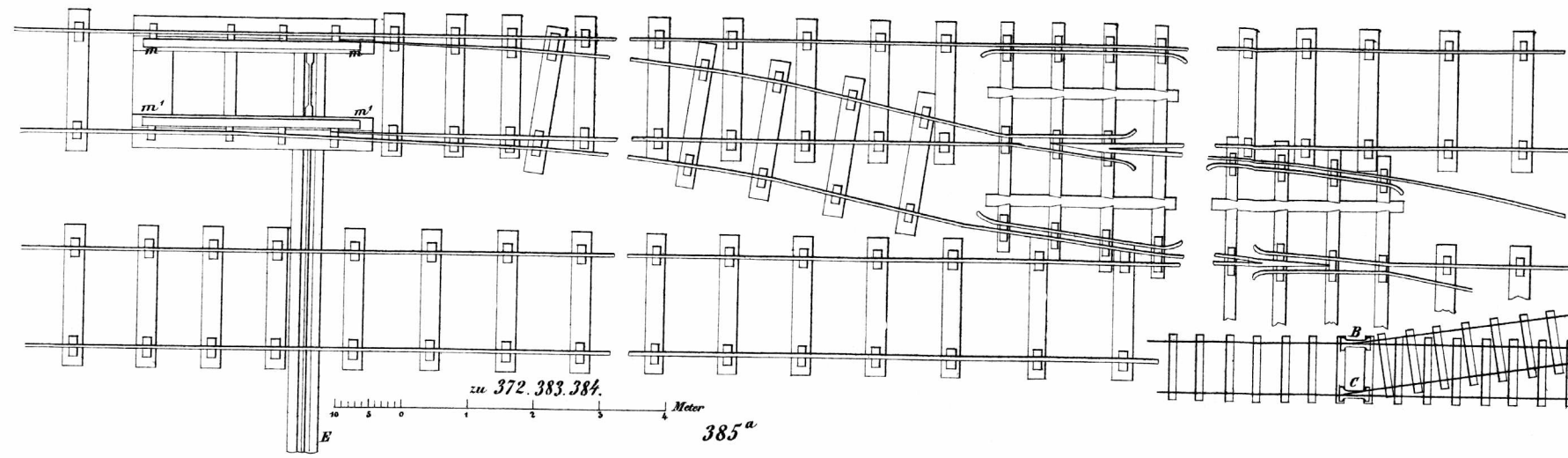

373.

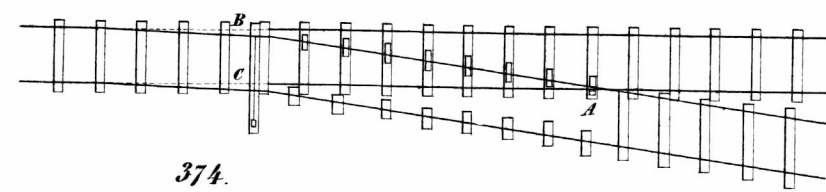

376.

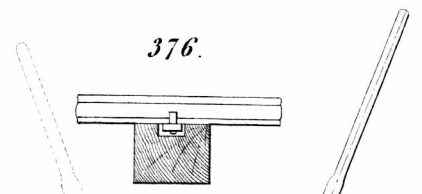

374.

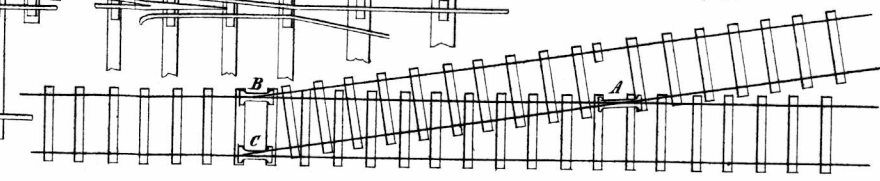

375.

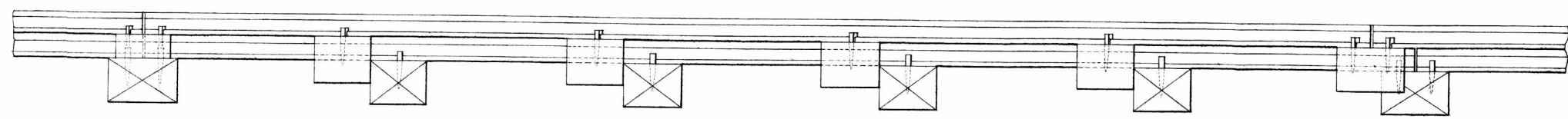
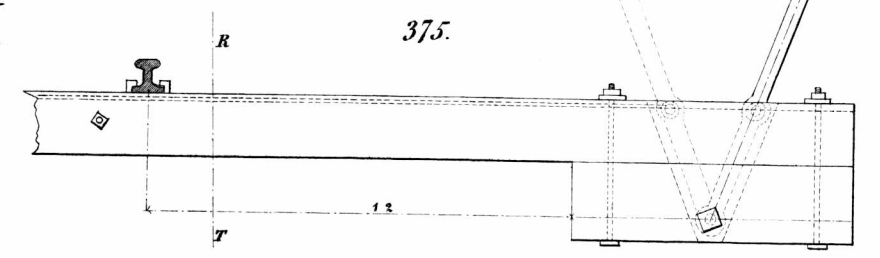

386.

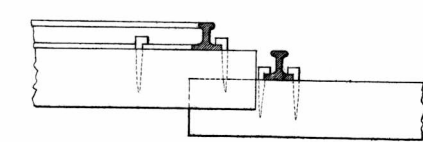

377.

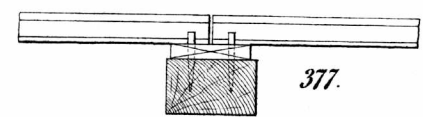

385.

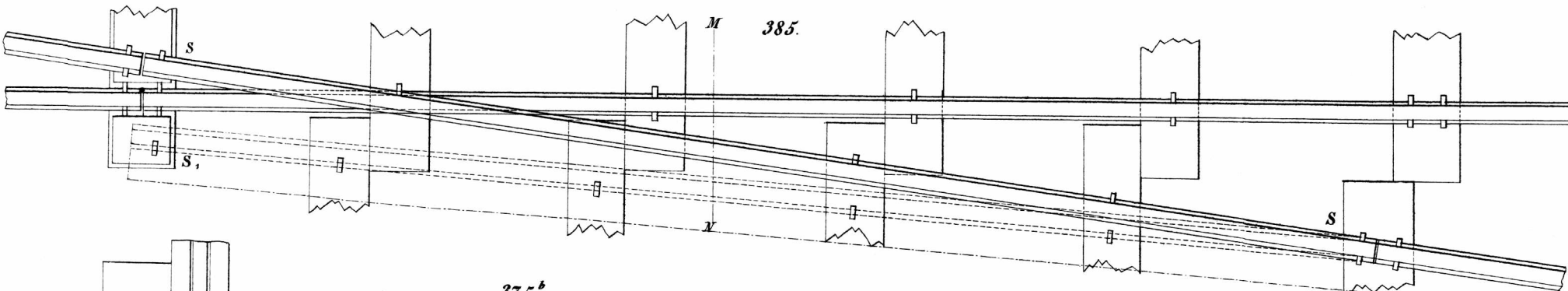

374^a

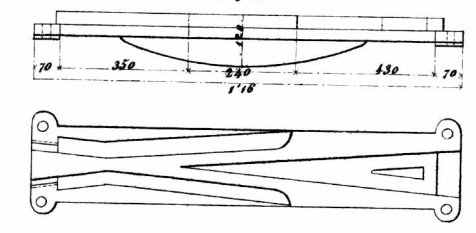

378.

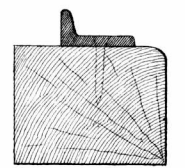

375^b

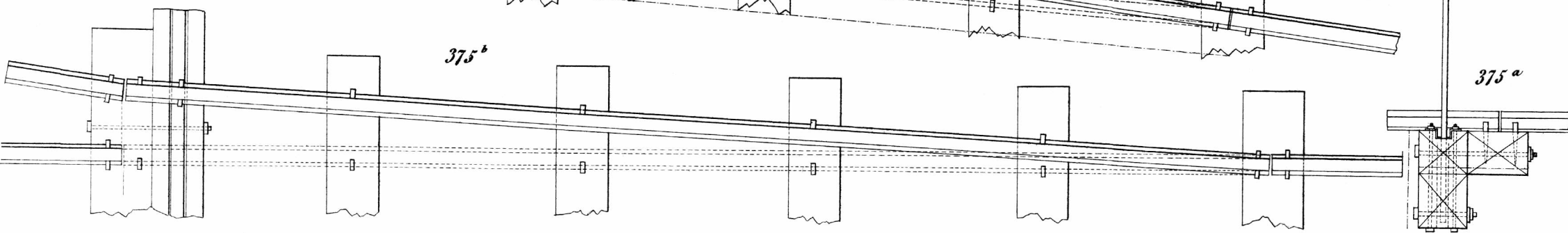

374^b

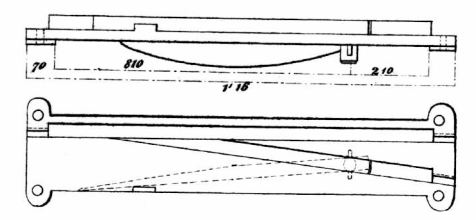

379.

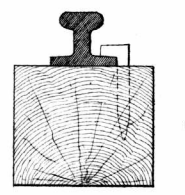

384.

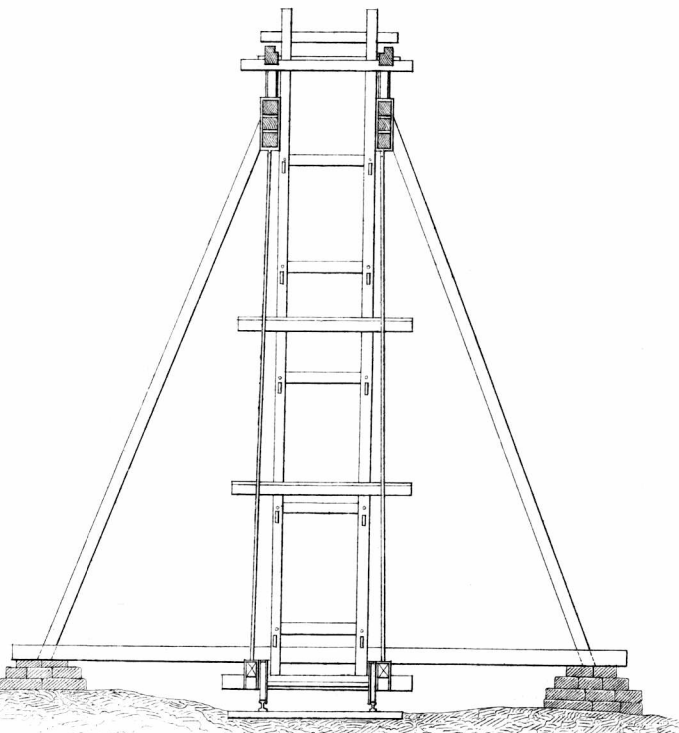

375^a

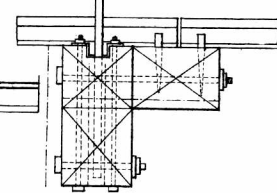

380.

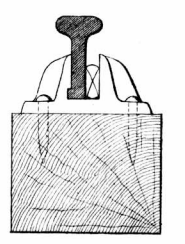

383.

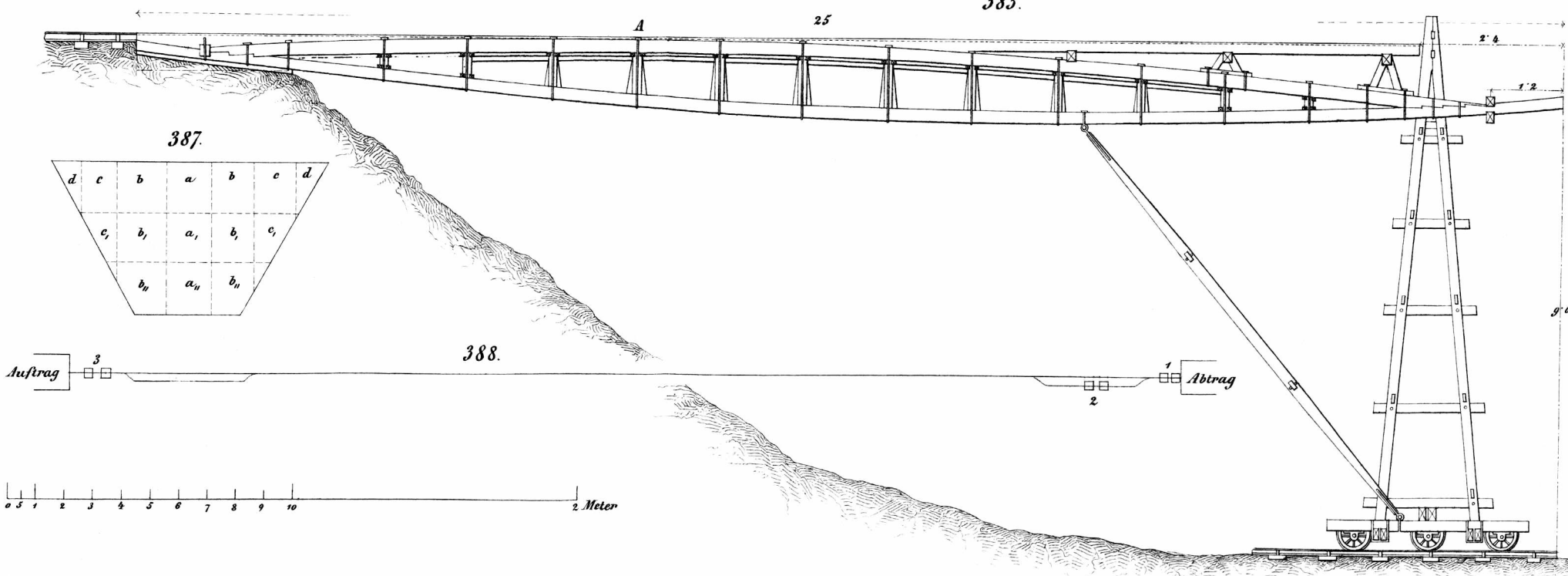

387.

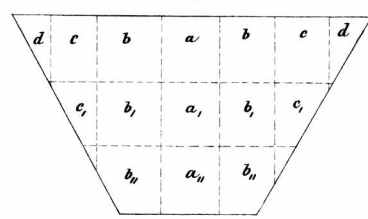

381.

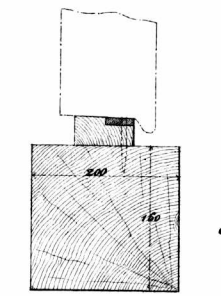

382.

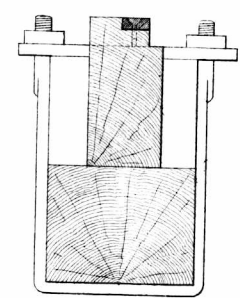

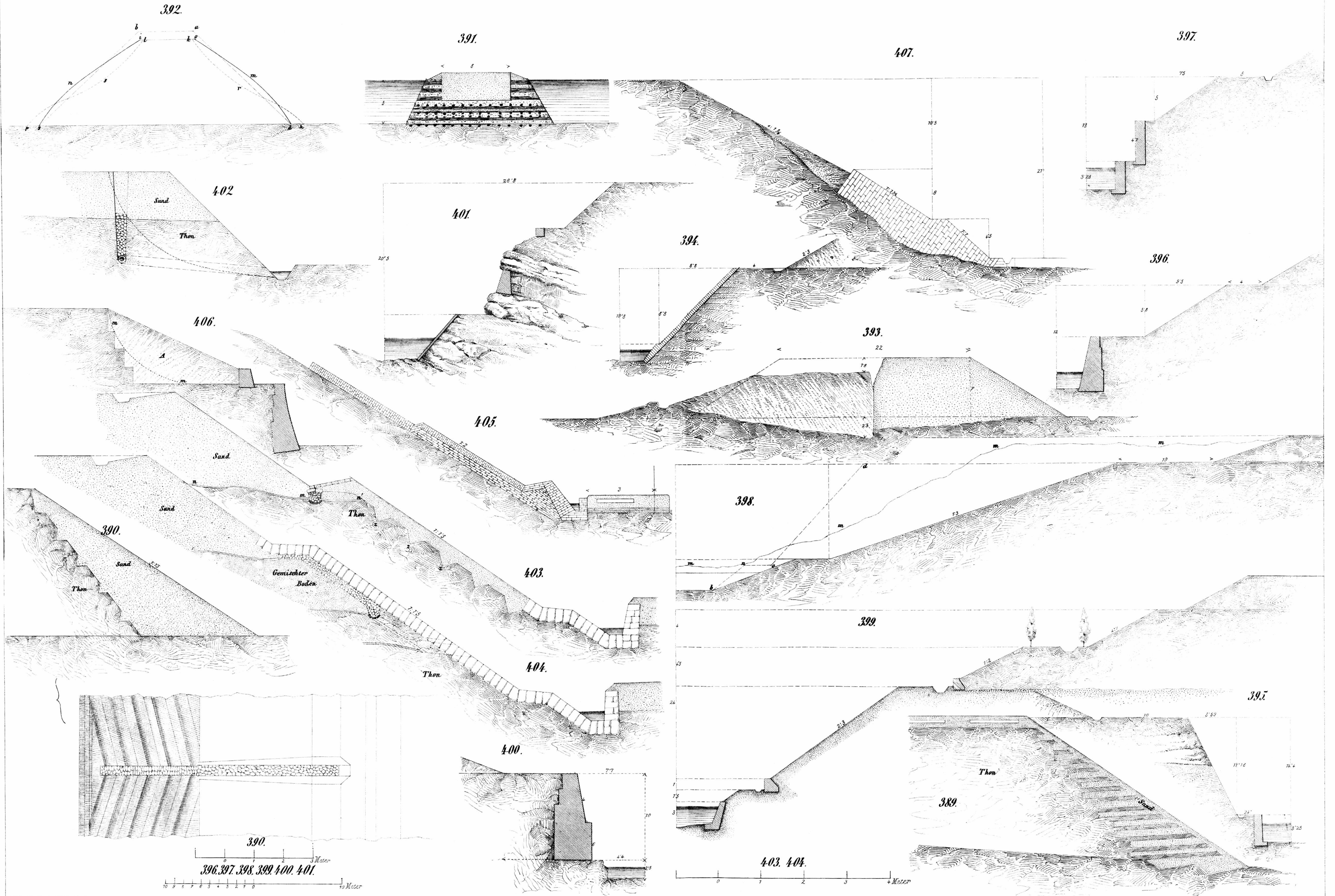

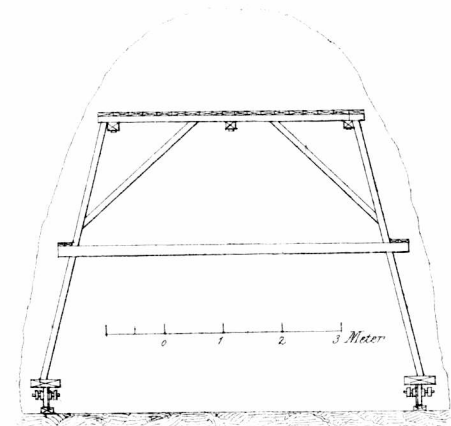

408.

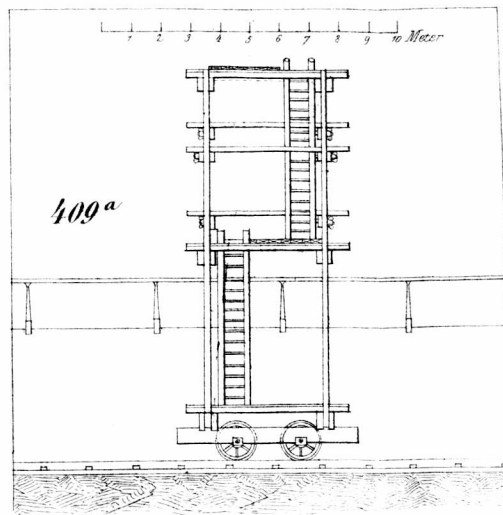
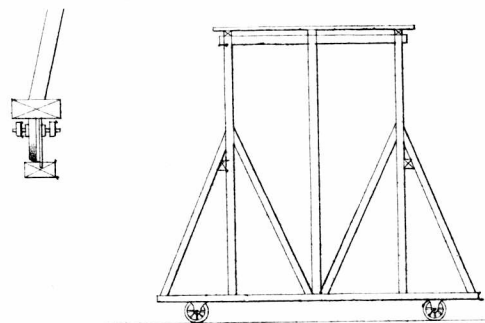

409a

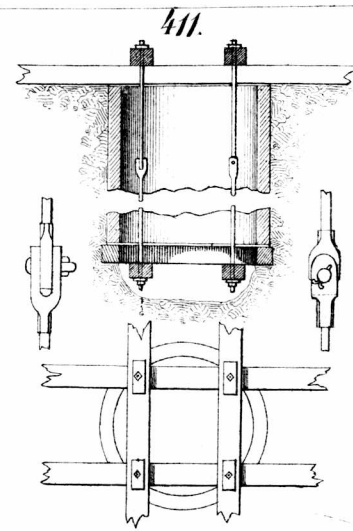

411.

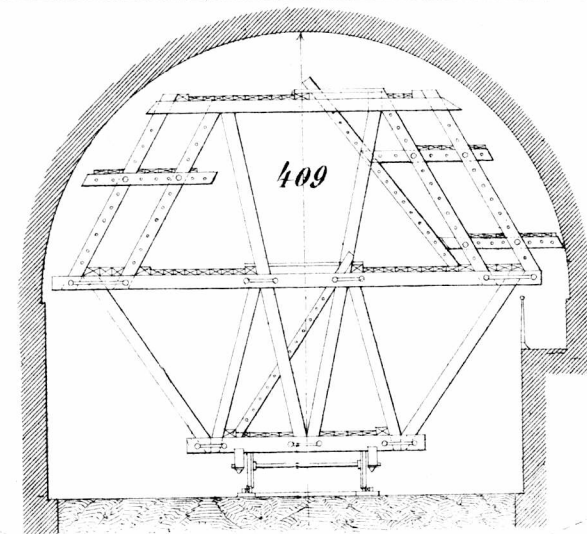

409

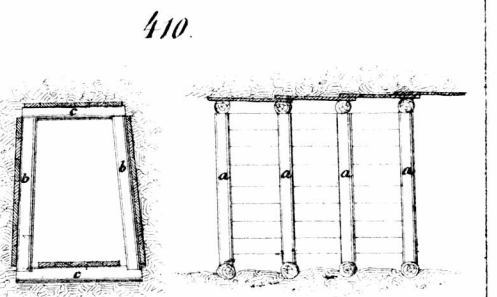

410.

413

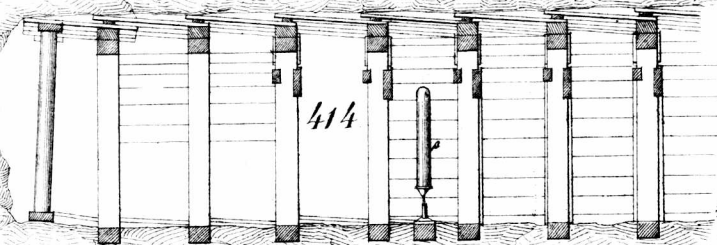
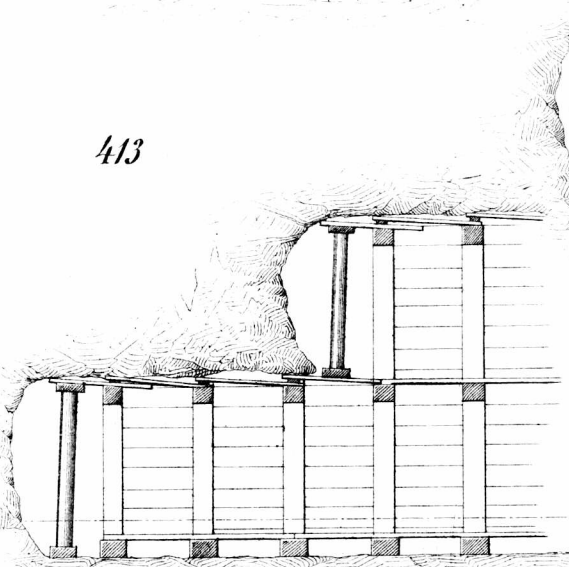

414

415

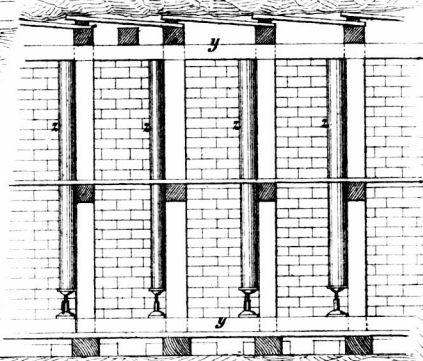

Schienehöhe

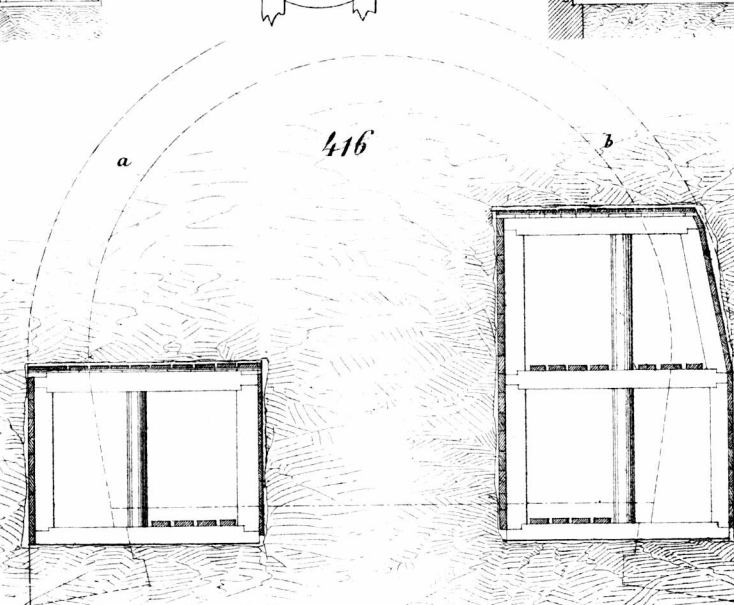

416

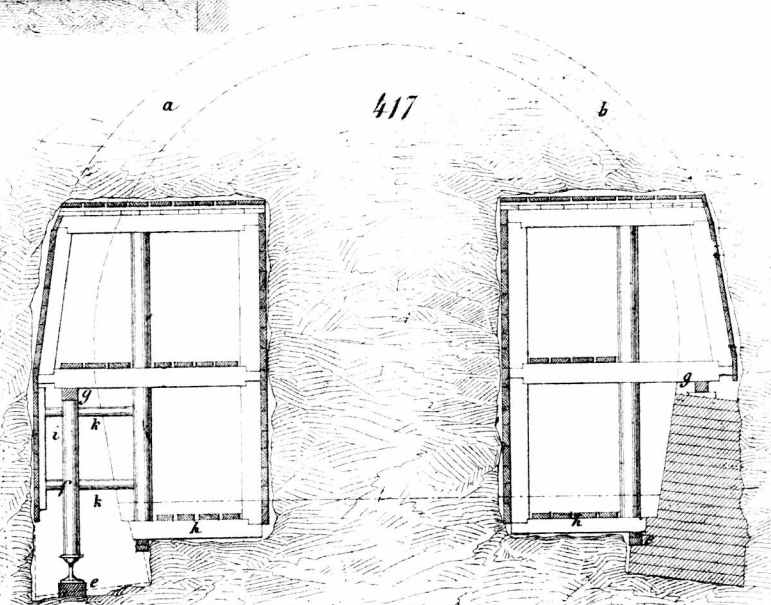

417

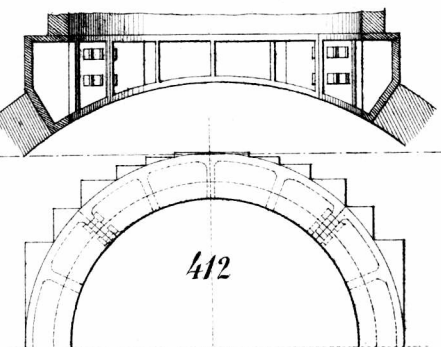

412

422

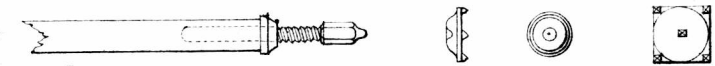

418

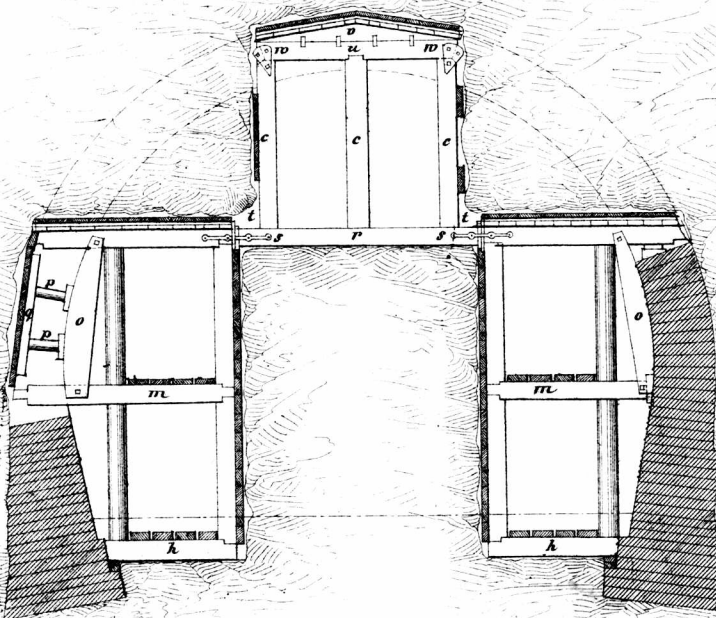

419

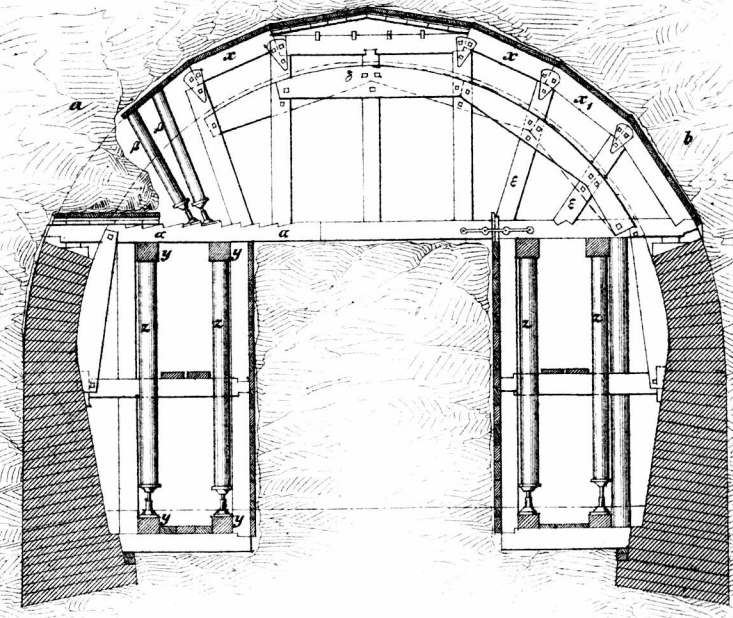

420

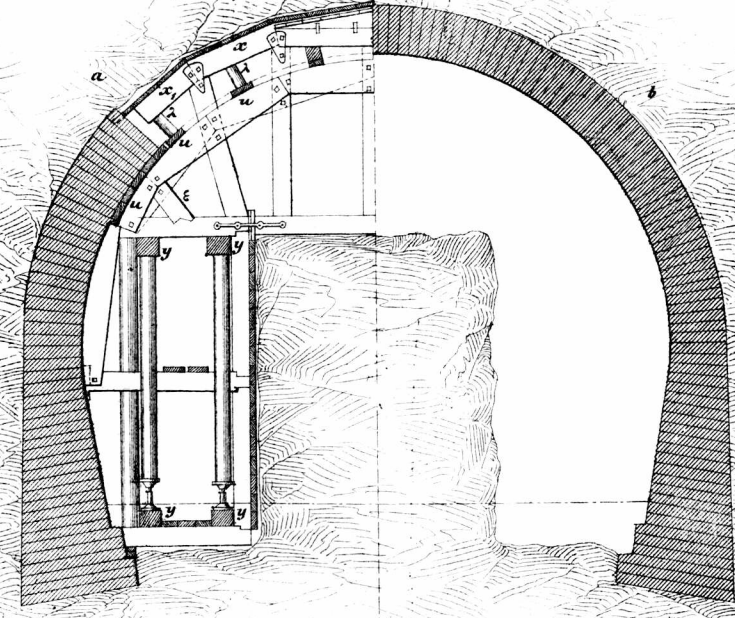

421

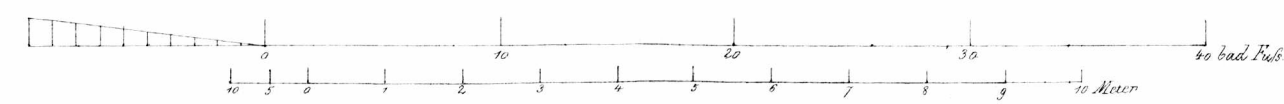
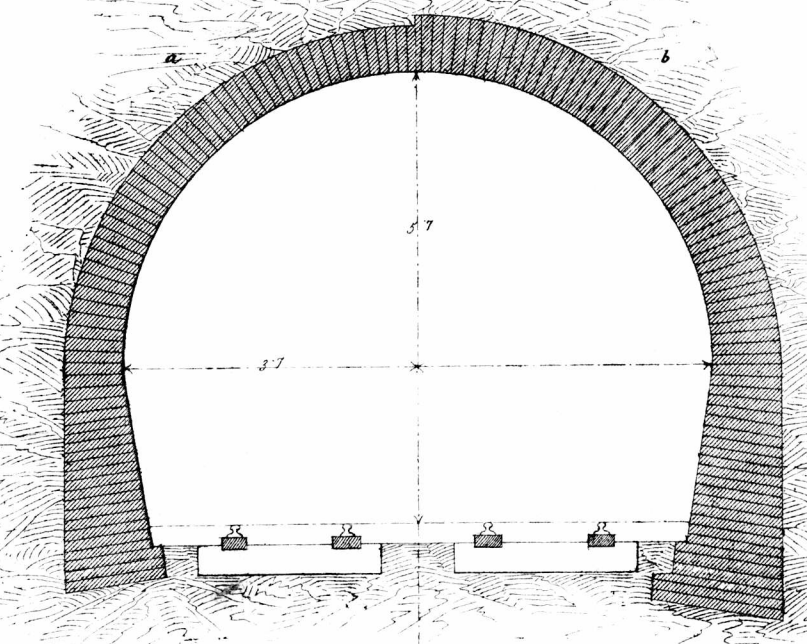

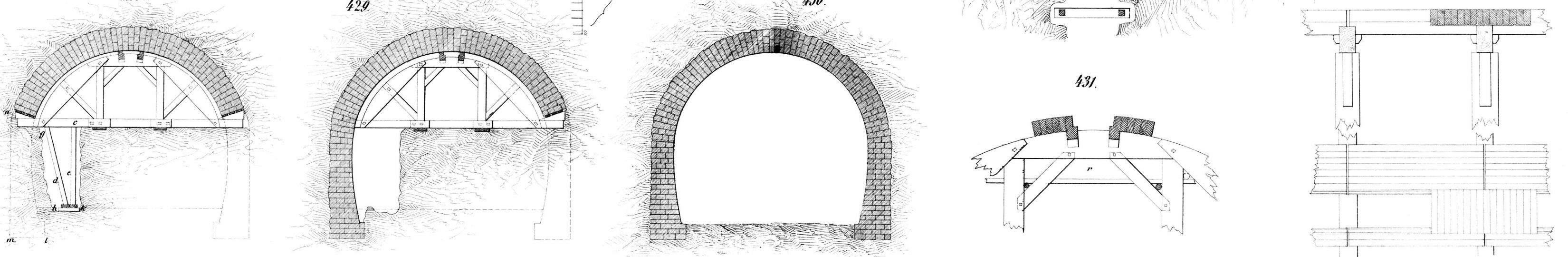
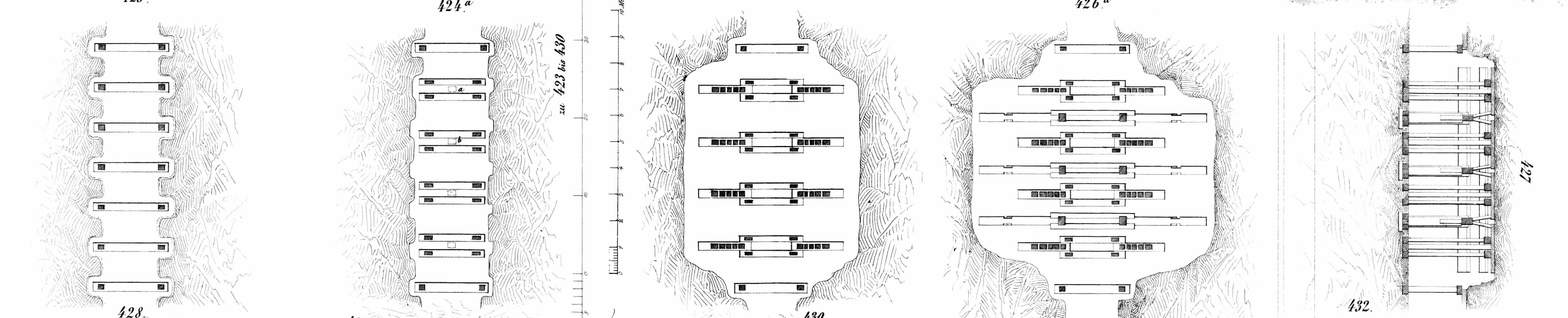
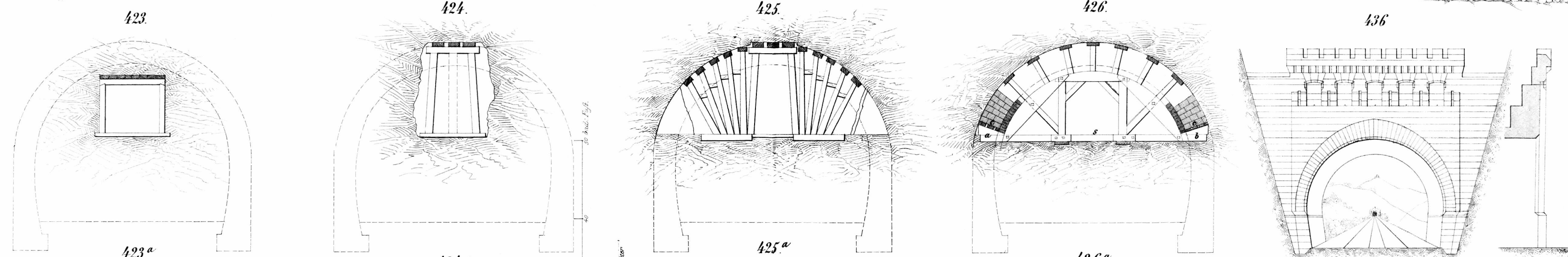
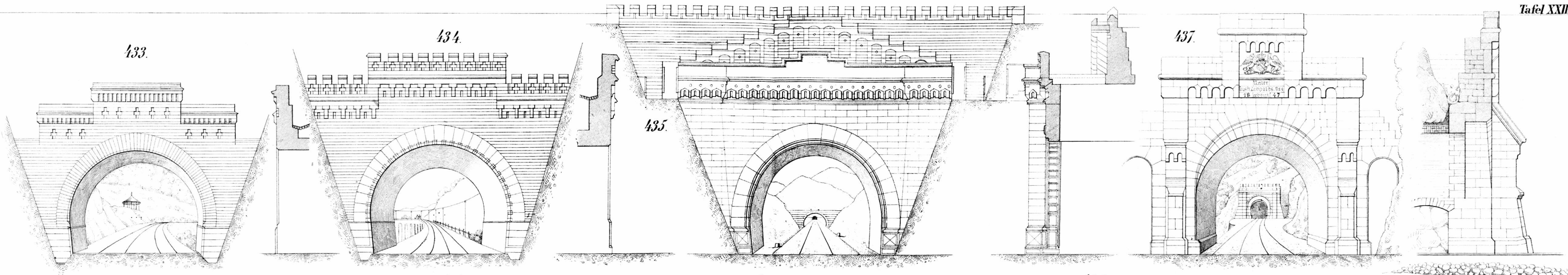

Vertical scale and measurement markings on the left side of the middle row of sections.

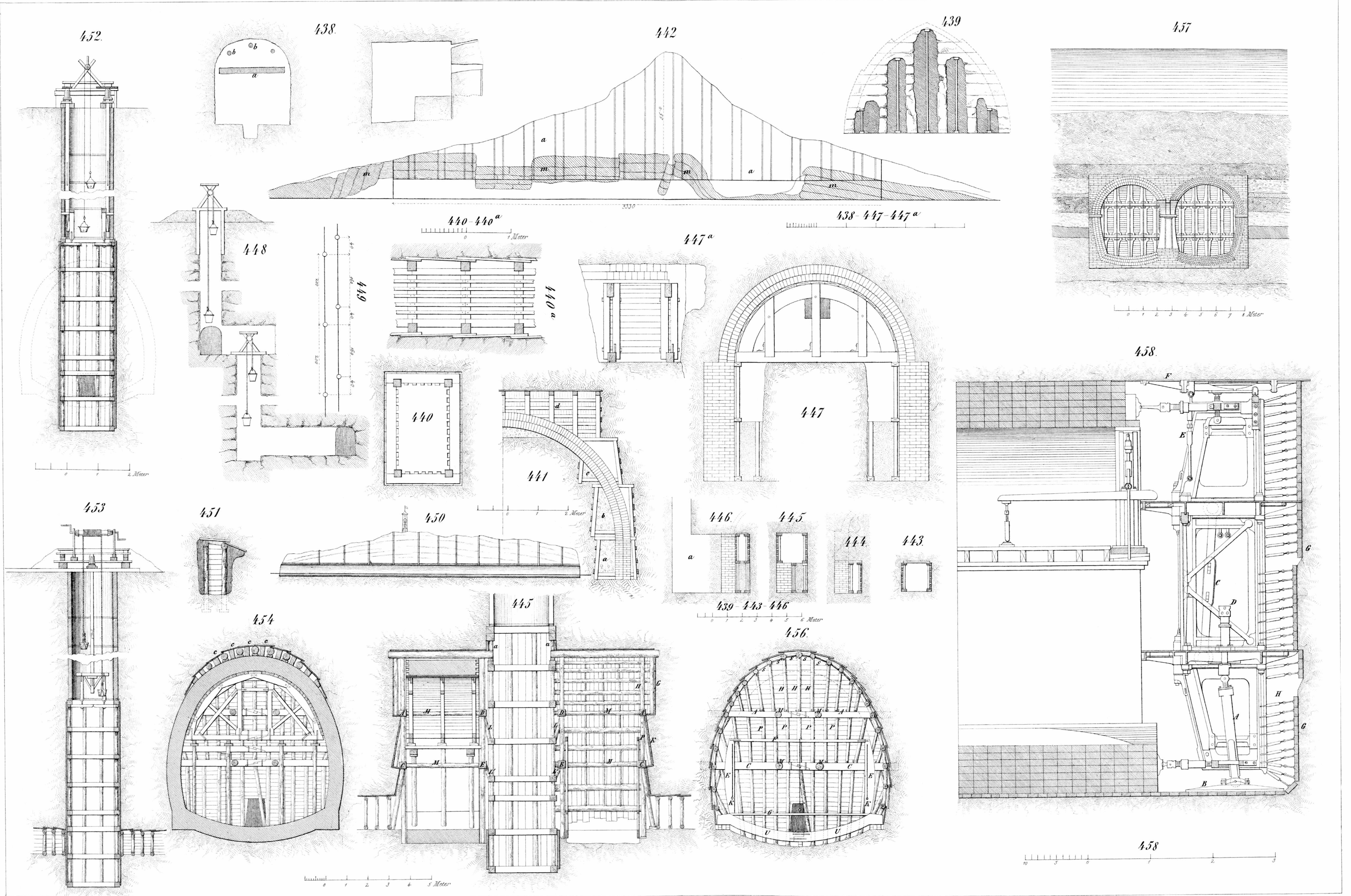

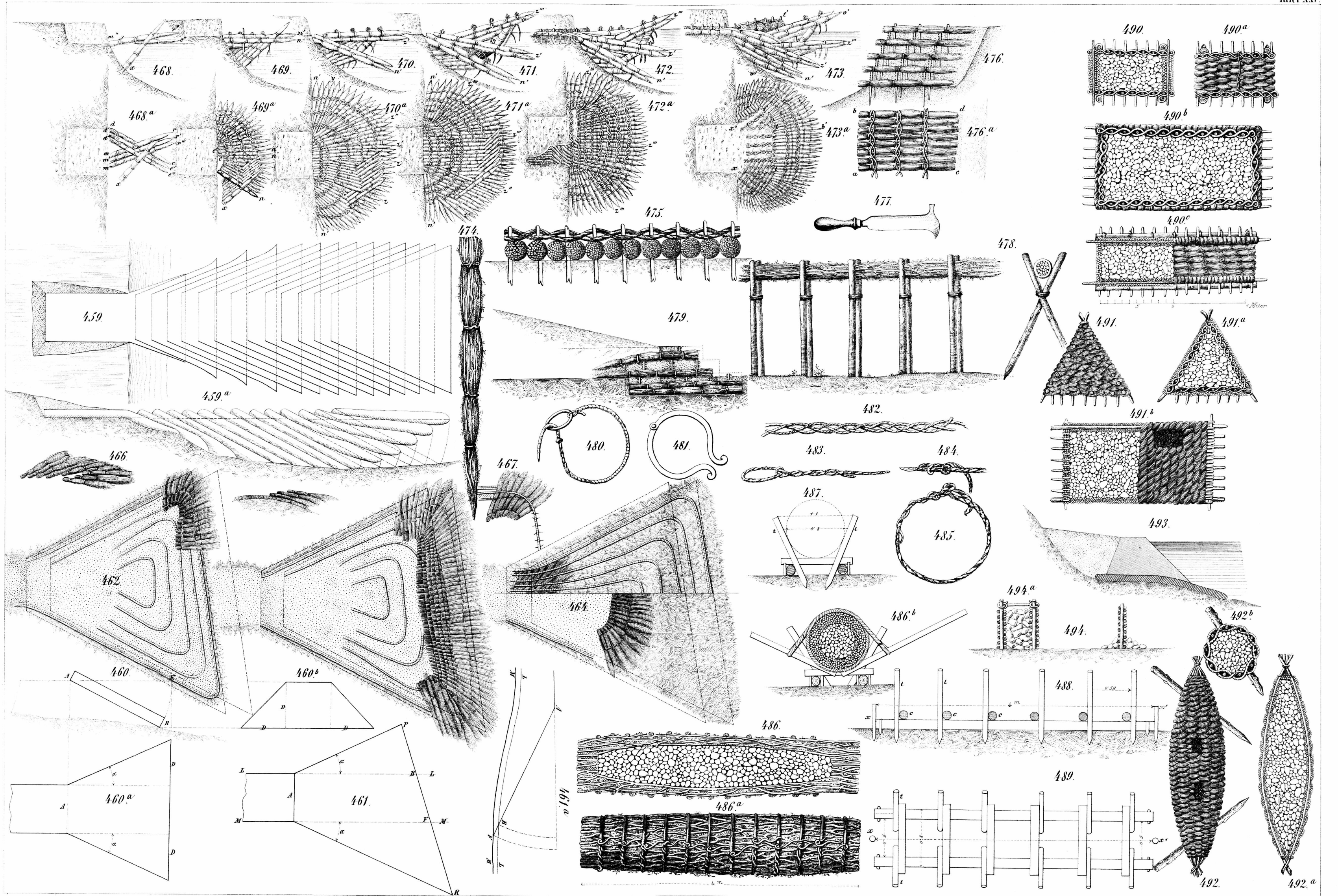

	<p>BIBLIOTEKA GŁÓWNA</p> <p>L 1851 m</p>
---	--