



NATURE

A WEEKLY ILLUSTRATED JOURNAL OF SCIENCE.

*"To the solid ground
Of Nature trusts the mind which builds for aye."*—WORDSWORTH.

No. 2417, Vol. 96

THURSDAY, FEBRUARY 24, 1916

[PRICE SIXPENCE.]

Registered as a Newspaper at the General Post Office.

[All Rights Reserved.]

BALANCES & WEIGHTS

Over a
Thousand
Balances
Always in
Stock.

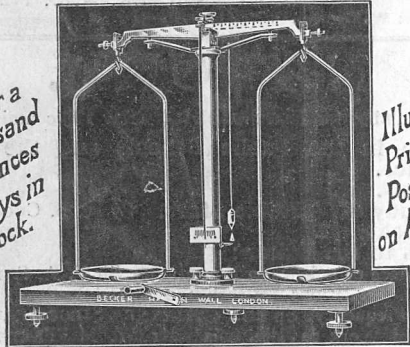

Illustrated
Price List
Post Free
on Application

BUY DIRECT FROM

**F. E. BECKER & CO., HATTON WALL,
LONDON, E. C.**
(W. & J. GEORGE, LTD., SUCCESSORS)

REYNOLDS & BRANSON, Ltd.,

Chemical and Scientific Instrument Makers to His Majesty's Government (Indian, Home, and Colonial). Laboratory Furnishers and Manufacturing Chemists.

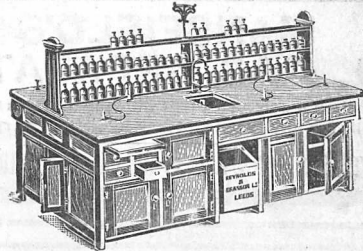

CHEMICAL, PHYSICAL, and TECHNICAL LABORATORIES
Fully Furnished with BENCHES, FUME CHAMBERS, &c.

INSTITUTIONS EQUIPPED INCLUDE:—

The National Shell Filling Factory, Leeds, and various Munition Works; The National Physical Laboratory, Teddington; Laboratories at Messrs. Brunner, Mond & Co., Ltd., Northwich; The Shelton Iron, Steel and Coal Co.; Science Laboratories at the Grammar School, Duffield, Btley, &c.; Imperial Service College, Windsor; Transvaal Dept. of Agriculture (Experimental Farm), Potchefstroom; The Technical Schools, Moleley and Yeadon; The Girls' High Schools at Barnsley, Beverley, Doncaster, Leeds, Nuneaton, Sherbourne, and York; Radley College, Oxford; The Schools, Shrewsbury; St. Mary's College, Winchester; and many others.

Catalogue of Chemical and Physical Apparatus and Chemicals post free.

Designs of Benches and Fittings to suit all requirements.

14 COMMERCIAL STREET, LEEDS.

JOHN J. GRIFFIN & SONS, LTD.

MAKERS OF

HIGH-CLASS PHYSICAL APPARATUS

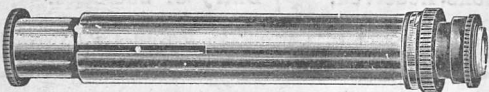

POCKET D.V. SPECTROSCOPE

With plain slit, 26/6; with adjustable slit, 33/-

RAINBAND SPECTROSCOPE, 54/-

Kemble Street, KINGSWAY,
LONDON, W. C.

Negretti & Zambra's

Deep-Sea Thermometers

Since 1857 N. & Z. have been making Deep Sea Thermometers. In 1874 they patented the original Reversing or Turnover pattern, the latest type of which is illustrated. Prompt delivery given.

Price List of Deep Sea Thermometers—free.

38 Holborn Viaduct, London, E.C.
City Branch: 45 Cornhill, E.C.
West End: 122 Regent Street, W.



NORTHERN POLYTECHNIC INSTITUTE, HOLLOWAY, LONDON, N.

The Governors of the above Institute invite applications for the post of ASSISTANT in the CHEMISTRY DEPARTMENT at a commencing salary of £120 per annum. The selected candidate would be required to start duties at once.

Particulars and form of application to be had on application to the SECRETARY.

MONMOUTHSHIRE TRAINING COLLEGE, CAERLEON.

WANTED immediately (for the duration of the war). LECTURER (man) to take Mathematics and Geography. For full particulars as to salary, &c., apply to the PRINCIPAL, Training College, Caerleon, Mon.

OLD PLATINUM, GOLD

Dental Alloy, Scrap, &c.,
Purchased for Cash or Valued.

SPINK & SON, Ltd.,

17 & 18 PICCADILLY, LONDON, W.
EST. 1772.

Fine Jewels or Plate also purchased or valued.

MANSFIELD'S OIL GAS APPARATUS

A simple compact plant which makes Gas from
Oil, for any Laboratory or Industrial Purpose.

MANSFIELD & SONS, Ltd., 11 Hamilton Sq., BIRKENHEAD

J. POOLE & CO

ESTABLISHED 1854

SCIENTIFIC & EDUCATIONAL BOOKSELLERS

Second Hand Books at about half published price.

:: :: New Books at discount price. :: ::

ENQUIRIES BY LETTER
RECEIVE IMMEDIATE ATTENTION

104 Charing Cross Road, London, W.C.

THE IRISH NATURALIST.

A Monthly Magazine of Irish Zoology, Botany, and
Geology. Price 6d.

Edited by Prof. GEO. H. CARPENTER, B.Sc., R. LLOYD
PRAEGER, B.A., and ROBERT J. WELCH.

Annual Subscription, 5s. Post Free to any Address.

Dublin: EASON & SON, LTD., 40 Lower Sackville Street
(to which Address Subscriptions should be sent).

BIRKBECK COLLEGE,

BREAMS BUILDINGS, CHANCERY LANE, E.C.

COURSES OF STUDY (Day and Evening) for Degrees of the
UNIVERSITY OF LONDON in the

FACULTIES OF SCIENCE & ARTS (PASS AND HONOURS)

under RECOGNISED TEACHERS of the University.

SCIENCE.—Chemistry, Physics, Mathematics (Pure and
Applied), Botany, Zoology, Geology.

ARTS.—Latin, Greek, English, French, German, Italian,
History, Geography, Logic, Economics, Mathematics (Pure
and Applied).

Evening Courses for the Degrees in Economics and Laws.

POST-GRADUATE AND RESEARCH WORK.

SESSIONAL FEES (*Day*: Science, £17 10s.; Arts, £10 10s.
Evening: Science, Arts, or Economics, £5 5s.

Prospectus post free, Calendar 3d. (by post 5d.) from the Secretary.

SOUTH-WESTERN POLYTECHNIC INSTITUTE, CHELSEA.

Day and Evening Courses in the Faculty of Science and
Engineering.

Special Day Courses for Munition Workers, for Pharmacy
and Dispensing, for Ambulance and Invalid Cookery.

Particulars of the Courses may be obtained on application.

SIDNEY SKINNER, M.A., Principal.

Telephone: Western 899.

NATURE.

The number for **last week (Feb. 17)** contained:—

Science in the Public Schools and the Civil
Service.

Catalysis.

The Study of Variable Stars. By H. E. GOODSON.

Our Bookshelf.

Letters to the Editor:—

The Place of Science in Education. Sir E. A. SCHÄFER,

F.R.S.—Relations between the K and L Series of the

High-Frequency Spectra. MANNE SIEGBAHN.—Educa-

tional Work in Museums. Dr. W. M. TATTERSALL.

—A Relation between Atomic Weights and Radio-active

Constants. (*With Diagram.*) A. VAN DEN BROEK.—

Asteroids Feeding upon Living Sea-Anemones. H. C.

CHADWICK.—Colourless Crystals of Hæmoglobin. Prof.

A. E. BOYCOTT, F.R.S.—Tubular Rock Structures.

(*Illustrated.*) GEORGE ABBOTT.

Wild Amazonia. (*Illustrated.*)

The American State and Household Science.

By A. S.

The Closing of Museums.

Notes. Our Astronomical Column.

British Production of Synthetic Dyes.

The Daily Food Ration of Great Britain. By

Prof. W. H. THOMPSON.

Harvard Contributions to Physics.

Forthcoming Books of Science.

The Organisation of Scientific Research. By

Prof. J. A. FLEMING, F.R.S.

University and Educational Intelligence.

Societies and Academies.

Books Received. Diary of Societies.

Copies can be obtained through any bookseller or newsagent, or post-
free from the Publishers, St. Martin's Street, London, W.C., on receipt of
6d. from residents in the British Isles, or of 7d. from residents abroad.



SECOND-HAND

MICROSCOPES, TELESCOPES, SURVEYING AND DRAWING
INSTRUMENTS, AND OTHER SCIENTIFIC APPARATUS AND
ACCESSORIES BY ALL THE BEST MAKERS.

338 HIGH HOLBORN, **CLARKSON'S** LONDON, W.C.

(Opposite Gray's Inn Road.)



LEWIS'S CIRCULATING MEDICAL AND SCIENTIFIC LIBRARY.

[Metropolitan Railway: Euston Square Station
All Tube Railways: Warren Street.]

Covering the subjects of Astronomy, Biology, Botany, Chemistry, Electricity, Engineering, Geography, Geology, Microscopy, Mining, Philosophy, Physics, Physiology, Sociology, Technology, Travels, Zoology, &c., in addition to Every Branch of Medical Science.

NEW WORKS AND NEW EDITIONS ARE ADDED TO THE LIBRARY IMMEDIATELY ON PUBLICATION.

SUBSCRIPTION, TOWN OR COUNTRY, FROM ONE GUINEA.

THE LIBRARY READING AND WRITING ROOM is open daily for the use of Subscribers.

Telegrams: "Publicavit, Eusroad, London." Prospectus, with Quarterly List of Additions, post free. [Telephone: Museum 1072.]

London: H. K. LEWIS & CO. Ltd., 136 GOWER STREET, W.C.

Received 3/15/16 Written
 Indexed M.S.R. Comdorse J.E.S.
 3-15-16
 3/16/16

An acceptable present for a Scientific man or Institution would be some of the Steel and Photogravure portraits contained in the series of

"Scientific Worthies"

A list of the portraits will be sent to any address by the publishers upon application.

Nature Office :

St. Martin's Street, W.C.

EDUCATION AND NATIONAL PROGRESS

ESSAYS AND ADDRESSES, 1870-1905.

BY

Sir NORMAN LOCKYER,
K.C.B., F.R.S.

8vo, 5s. net.

* * * This Volume contains "The Influence of Brain-Power on History," being the Author's Presidential Address at the British Association Meeting at Southport in 1903.

MACMILLAN & CO., LTD., LONDON.

NOTICE.

For the convenience of readers of NATURE wishing to inspect books published abroad which have been reviewed in NATURE such volumes are kept for the period of six months at the publishing office of the journal. The books are retained for the purpose of examination free of charge.

St. Martin's Street, London, W.C.

The Advantages of the
WILLETT
Laboratory
Heating System

No. 4.

The Gauze Top
Large Flame Burner



This piece of Willett Apparatus gives a very large flame. It is particularly useful for boiling large flashes, stills, &c. The Willett System can be used with equal success for every heating operation which can be undertaken with the aid of coal-gas.

The plant is compact, simple, and absolutely reliable. It is substantially built throughout, and all parts liable to rust are made of brass or copper.

The Willett plant can be shipped abroad complete ready for immediate erection, or in parts.

Write to-day for Booklet "T," which gives full particulars of this reliable system, and, if possible, visit the showrooms, where a full demonstration can be seen.

W. WILLETT,

37^F Sloane Square, London, S.W.
The house with over 40 years' reputation.

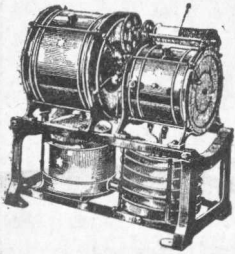

THE "FORTINETTE"
STANDARD BAROMETER

(Each barometer is marked "Fortinette.")

Registered Design No. 420,207.

Designed to meet the requirements of Students and others who find the need of a Barometer which will give exact readings, and cost but a moderate sum.

Used for demonstration purposes in all the principal Science and Technical Colleges, and adopted by the L.C.C. for use in their Classes.

N.B. We wish to emphasize that this is a STANDARD BAROMETER, made on the SAME principle as the larger Fortin's Barometer, and gives readings to .01 inch and .1 millimetre.

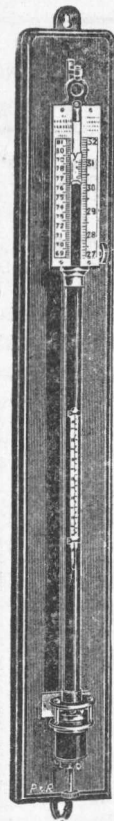

We confidently recommend this Instrument for use as a "Standard" in Colleges and Schools, private Observatories, and by Gas and other Engineers.

Price complete, mounted as illustrated,

£4 10 0

Nat. Phys. Lab. Certificate, if desired, 10s. extra.
GLAZED CASE (Oak) with lock, to contain above Barometer, **£2 2 0**

NATURE says:—"Provides an accurate instrument at a moderate cost."

DESCRIPTIVE CIRCULAR POST FREE.

Sole Manufacturers and Proprietors of the Regd. Design:

PASTORELLI & RAPKIN, Ltd. (ESTAB. 1750.),
46 HATTON GARDEN, LONDON, E.C.

ACTUAL MAKERS OF ALL KINDS OF METEOROLOGICAL INSTRUMENTS
Contractors to H.M. Government.

ILLUSTRATED PRICE LISTS POST FREE

*. We pay carriage and guarantee safe delivery within U.K. on all our instruments.

— THE —

British Laboratory Ware Association, Ltd.

An Association formed by the principal Chemical Apparatus Dealers in this country who are now ready to supply the following British-made Glass Ware, Porcelain, Filter Papers, &c., which have all been tested and approved by well-known Scientists, and the Association has every confidence in recommending same for general Laboratory work:—

GLASS BEAKERS, made from a formula similar to Jena, spouted, from 100 cc. to 1500 cc.

" " " " " plain, from 50 cc. to 1000 cc.

FLASKS, made from a formula similar to Jena, ordinary shape, from 50 cc. to 1000 cc.

" " " " " conical, from 50 cc. to 1000 cc.

PORCELAIN EVAPORATING BASINS AND BEAKERS.

PORCELAIN CRUCIBLES AND COVERS, Nos. 000 to 5.

FILTER PAPERS, equal to Schleicher & Schüll's, including No. 589 (white and black band), and No. 595.

NICKEL EVAPORATING BASINS. NICKEL CRUCIBLES & COVERS.

The above are obtainable from the following firms, all Members of the Association:—

BIRMINGHAM ... BELCHER (STANDLEY) & MASON, Ltd., Church Street.	LONDON ... F. E. BECKER & CO. (W. & J. George, Ltd., Successors, 1807), Hatton Wall, E.C.
" ... PHILIP HARRIS & CO., Ltd., 144-6 Edmund Street.	" ... A. GALLENKAMP & CO., Ltd., 19-21 Sun Street, E.C.
" ... SOUTHALL BROS. & BARCLAY, Ltd., 1 Broad Street.	" ... JOHN J. GRIFFIN & SONS, Ltd., Kemble Street, Kingsway, W.C.
BRADFORD ... HARRISON, PARKINSON & CO., Ltd., Sun Bridge Road.	" ... TOWNSON & MERCER, Ltd., 34 Camomile Street, E.C.
BRISTOL ... FERRIS & CO., Ltd., Union Street.	MANCHESTER ... F. JACKSON & CO., Ltd., 44 Chapel Street, Salford.
EDINBURGH ... A. H. BAIRD, 33-39 Lothian Street.	" ... JAMES WOOLLEY, SONS & CO., Ltd., Victoria Bridge.
GLASGOW ... BAIRD & TATLOCK, 45 Renfrew Street; and Branches.	NEWCASTLE-ON-TYNE ... BRADY & MARTIN, Ltd., Northumberland Road.
LEEDS ... REYNOLDS & BRANSON, Ltd., 14 Commercial Street.	SHEFFIELD ... J. PRESTON, 105 Barker's Pool.
	WIDNES ... J. W. TOWERS & CO., Ltd., Victoria House.

THURSDAY, FEBRUARY 24, 1916.

THE OXFORD ARISTOTLE.

- (1) *The Works of Aristotle*. Translated into English under the Editorship of W. D. Ross. *Magna Moralia, Ethica Eudemia, and De Virtutibus et Vitiis*. Unpaged. (Oxford: At the Clarendon Press, 1915.) Price 5s. net. Also: *De Mundo and De Spiritu*. (Oxford: At the Clarendon Press, 1915.) Price 2s. net.
- (2) *Illustrations of Positivism*. By J. H. Bridges. New Edition. Pp. xiii+480. (London: Watts and Co., 1915.) Price 3s. 6d. net.

(1) THE thanks of all English-speaking students of philosophy and of the history of science are owing for the steady progress which is being made by the Oxford Press in the translation into English of the whole Aristotelian corpus. With regard to the works under review, the student of ethics who is not also a first-rate Greek scholar, owes a special debt of gratitude to Mr. J. Solomon and to Mr. St. George Stock: to the former for his very accurate version of the "Eudemean Ethics." As Mr. Solomon and Mr. Stock both point out, this work has generally been neglected by Aristotelian scholars. But this neglect is surely unreasonable. The "Eudemean Ethics" is at least a commentary on Aristotle's own "Ethics" by a personal pupil reputed to have been best acquainted with Aristotle's mind, and should therefore be authoritative for the understanding of the master's meaning.

Mr. Stock not only gives us an admirably clear and forcible translation of the "Magna Moralia," but he has also provided indexes and detailed tables of contents for this work and for the "Eudemean Ethics." Further, in a short but vigorously written introduction he discusses the whole question of the relations of all three moral treatises which go under the name of Aristotle one to another. As he says, the problem is not unlike that of the three Synoptic Gospels. "All three used once to be ascribed to the direct authorship of Aristotle with the same simple-heartedness, or the same absence of reflection, with which all three Gospels used to be ascribed to the Holy Ghost." A special form of the general question is the question whether the three books common to the "Nicomachean" and the "Eudemean Ethics" (E.N. v., vi., and vii., E.E., iv., v., and vi.) proceed directly from the writer of the former, assumed to be Aristotle, or from Eudemus, the writer of the latter. This question, Mr. Stock observes, is of no great importance, because in any case the doctrine is Aristotle's.

The prejudice in favour of the former work is not peculiar to Oxford, where students are nurtured on the "Nicomachean Ethics," or to English or foreign universities, or to modern times, for Grant pointed out that whereas many Greek and Latin writers have written commentaries on the "Nicomachean," there has been no such commentary on the "Eudemean Ethics."

Mr. Stock dismisses somewhat summarily the contention of Prof. Burnet that the curious mathematics of the fifth book must be due to Aristotle, who was no mathematician, and not to Eudemus, who was one of the first mathematicians in an age in which mathematics made more progress than it ever did subsequently until the seventeenth century. Does not this contention reduce, Mr. Stock asks, to the bare statement that Eudemus wrote on mathematics? And have we any independent evidence that Aristotle was so poor a mathematician? The arguments which Mr. Stock marshals for deciding the authorship of the three disputed books are too detailed to be quoted here. His conclusion, arrived at mainly on linguistic grounds, is that the three books contain Aristotle's own doctrine, but that they were not written by him in the form in which we now have them. Part of them, at any rate, we have only as worked up by Eudemus and adjusted to the latter's own work.

Mr. E. S. Forster gives us an extremely spirited version of the "De Mundo," a work which is certainly unauthentic and probably based on two works of Poseidonius, the *Μετεωρολογικὴ στοιχείωσις* and the *Περὶ κόσμον*. Prof. J. Dobson is to be congratulated on the success with which he has grappled with the difficulties of the text of the "De Spiritu."

(2) In the second edition of the late J. H. Bridges's "Illustrations of Positivism," issued by the English Positivist Committee under the editorship of Mr. H. Gordon Jones, a number of papers (many of them were originally delivered as addresses or lectures) are included which were published posthumously in the *Positivist Review*. Mr. Jones has also classified all the papers according to their subject-matter, and supplied numerous bibliographical and explanatory footnotes, as well as an index. To the present-day reader some of these essays may seem to breathe the breath of bygone controversies. Others, on the contrary, as, for example, the brief account of Captain A. T. Mahan's book, "The Influence of Sea-Power upon History," will be read with special interest to-day. Whatever topic he wrote on, Bridges was never dull. He was possessed of an extraordinarily fine sense of historical perspective, and,

accordingly, everything he wrote was informed with a magnanimity which makes these articles something more than mere journalism. Written as they mostly were for the *Positivist Review* by way of commentary on current literary and social events, their sanity and directness of presentation and their simplicity of style have done much in this country to win acceptance for Positivist doctrine.

E. H. STRANGE.

MECHANICS AND ENGINEERING TECHNOLOGY.

- (1) *Mechanical Technology: being a treatise on the Materials and Preparatory Processes of the Mechanical Industries.* By Prof. G. F. Charnock. Pp. x+635. (London: Constable and Co., Ltd., 1915.) Price 7s. 6d. net.
- (2) *The Theory of Machines.* By R. F. McKay. Pp. viii+440. (London: Edward Arnold, 1915.) Price 15s. net.

THERE is a peculiar fitness in bracketing the two above-mentioned books together, inasmuch as they represent almost entirely opposite views of the training of young engineers. By way of illustrating this it may be remarked that the second volume on inspection shows itself the product of an analytic mind, and deals on mathematical lines with the consideration of dynamical and statical forces and their results; thus this volume is one that would only indirectly appeal to the artisan or assistant works manager, and yet is one that should be thoroughly understood by the designer and chief draughtsman. The first volume is, as its heading suggests, a sound descriptive treatise of the most general processes and methods of dealing with raw materials, such as timber, iron, steel, alloys, etc., in order to fashion them into shapes of direct utility. There are in this volume some valuable tables of data obtained from the testing of materials, but there is no mathematics of any kind save a very elementary expression used on pages 6 and 7 in a paragraph on modulus of elasticity. The volume thus has only an indirect interest for the designer but is intensely interesting to the works manager's department, as it is wholly concerned with the properties of the materials used and the methods by which those materials are treated.

(1) This volume on mechanical technology is divided into five parts, the first of which deals with the physical properties of the raw materials: steel, iron, timber, stone, etc., and gives tables of strengths, weights, durabilities, etc. The second portion (150 pages) deals with the manufacture of mild steel, the copper alloys, wrought iron, with a short chapter on the heat treatment of steel. In the chapter on timber the various

methods of preserving timber against decay are given, but it is noticeable that "yellow deal" is not given as being used for "street paving blocks." In London most of the streets are now being paved with soft deals, creosoted, and the harder Australian woods, karri and jarrah, are used by the side of the tramway routes. It is good to notice a chapter on oils and lubricants, in view of the immense service of the latter in machine shops and motor transport work. Large buyers of oils should always insist on the regular testing for viscosity and lubricating power, and the variation with rise or fall of temperature. A short chapter on indiarubber concludes this portion of the book. It could be wished that the author had included some details of the manufacture of mechanical rubber goods, such as tyres, etc., seeing that rubber plays such an important part in modern industry. It would be interesting at the moment of writing to know the progress made in Germany in the synthetic production of rubber for mechanical purposes.

Part ii, consists of 170 pages, and is devoted to modern foundry equipment and methods of moulding. This portion of the treatise should be very valuable to engineering students, and it has the merit of many excellent illustrations. Here, again, the reader cannot help regretting that German manufacturers should be able to turn out steel castings which in so many cases are better in quality and finish, together with cheapness, than is the case with us. It is indeed to be hoped that more scientific control of temperatures and mixings will bring back to us pre-eminence in all classes of foundry work. Part iii, devotes 150 pages to "The Smithy and Modern Forging." The book concludes with some chapters on wire drawing and wire-drawing machinery, and the manufacture of weldless tubes. A list of books of reference which give an extended treatment of the various portions of this treatise, together with a full index at the end, is a pleasing feature. As can be seen from this survey, the book is a very helpful source of information to a student whilst at college, and should be heartily recommended to such a one before he enters the shops.

(2) The education of the mechanical engineer at college is to a very large extent concerned with the teaching of mathematics and its application to engineering design, hence the student spends a relatively large amount of time in the drawing office and lecture rooms, and all too little in the workshop and engineering laboratory. Probably every good teacher would like to give courses of lectures on mechanical technology, but the time at his disposal is all too short, hence this part of the student's knowledge is left for him to pick up

whilst he is actually serving an apprenticeship. The consideration of stress distribution in structures, the effect of dead and live loads, etc., to name only two of many problems in applied mechanics, indicate the type of knowledge which it is the function of colleges to instil, and the outcome of this method of teaching and procedure is the volume under notice.

From the large number of examples appended to each chapter it is to be presumed that the volume deals with the work required by the examinations of the Institution of Civil Engineers and the University of London. Therein lies one defect, viz., that the volume, however excellent its contents may be, is concerned with the attempt to cover a syllabus rather than with the education of a recruit for a live and active industry. The effect of examinations has often been to narrow and cramp the education of a student, and the aim of a college can easily be turned into one of passing a maximum number of students through a given examination rather than fitting such men for an industry which is continually changing in scope and methods. Consider the immense change in almost every branch of engineering work in the last ten years, and the consequence should be that every syllabus of engineering examinations needs revision at least once in a decade. To return, however, to the book under review, the contents are so clearly set out and defined that it is evident the author is a sound teacher. Students of mechanism and the theory of machines cannot do better than work through the various chapters of this book. At the end of so doing they can face with confidence any problems that may arise on such subjects as the profile of wheel teeth, acceleration and accelerating forces, the balancing of engines, cams, trains of wheels, frictional resistances in machines, and the like. Chapter xxx. might with advantage have included a description of the Froude water dynamometer, a machine which will readily absorb any horse-power up to 1000 or more, as the limits of the rope-friction brake are so low.

A. J. M.

METAMORPHIC GEOLOGY.

Metamorphic Geology: A Text-book. By C. K. Leith and W. J. Mead. Pp. xxiii+337. (New York: Henry Holt and Co., 1915.) Price 2.50 dollars.

THIS book is divided into four parts. The first deals with the alteration of rocks by surface agencies (katamorphism), the second with cementation and alteration by deep-seated agencies (anamorphism), the third with the general principles of metamorphism, and the fourth with

laboratory work on the subject. The authors concern themselves rather with results than with the chemical and physical processes by which those results are brought about, and they endeavour so far as possible to apply quantitative methods. A special feature of the book is the representation, by graphic methods, of the relative gains and losses of the chemical constituents during metamorphism.

At the conclusion of the first part, after dealing with the weathering of igneous rocks and the nature of the sediments resulting from the erosion, transportation, and redeposition of the weathered material, the authors estimate the amounts of shale, sandstone, and limestone which would be formed by the decomposition and disintegration of an igneous rock of average composition, the assumption being that sedimentary rocks and ocean salts have been derived directly or indirectly from known igneous rocks. We quote the results as illustrating the authors' point of view, and also because of their intrinsic interest. By methods that cannot be here described the conclusion is reached that "100 grams of average igneous rock yield 114 grams of end-products, consisting approximately of 87.8 grams of shale, 12.9 grams of sandstone, 6.7 grams of limestone, and 6.6 grams of ocean salts. Neglecting the ocean salts, these figures correspond to 82 per cent. of shale, 12 per cent. of sandstone, and 6 per cent. of limestone."

A comparison by volume of the average igneous rock with the sediments assumed to be derived from it also leads to interesting results. The volume of the sediment is greater than that of the igneous rock owing (a) to addition of material, (b) to development of minerals of lower specific gravity, and (c) to porosity. That due to (a) is estimated at 7.4 per cent., that due to (b) at 3.6 per cent., and that due to (c) at 17 per cent. on the average, giving an increase of 28 per cent. If the ocean salts be also taken into consideration the total increase becomes 36.9 per cent. The salts of the ocean correspond to 72,000,000 cubic miles of igneous rock and to 92,000,000 cubic miles of sediment. This would represent a thickness of about 0.46 mile over the entire globe, or of 1.39 miles over the continental areas.

The phenomena of "anamorphism" (metamorphism in the sense in which that term is generally used in this country) are dealt with in the second part of the book, and the views of Becke and Grubenmann on the origin of the crystalline schists are discussed. Apart from the diagrams already referred to, only two illustrations are given, and it is difficult to understand why these have been selected from a host of others of at least equal importance.

Some familiar terms are used in a sense that is not likely to find favour on this side the Atlantic. Take, for instance, the following on p. 108: "Extreme induration and recrystallisation of a shale, independent of dynamic action or contact-metamorphism, may produce a highly crystalline rock without cleavage, to which the term slate is usually applied. . . . It is not convenient or necessary to apply any other term than slate to these rocks." A slate without cleavage! Again, on p. 173: "the complete granulation of constituents is sometimes expressed by the term mylonite." The complete granulation of the constituents of a rock gives rise to a *granulite*, not a *mylonite*. Granulites and mylonites may be produced from one and the same rock, but not under the same conditions; hence the necessity of keeping the terms distinct.

The third part of the work treats of such questions as the methods of distinguishing metamorphic rocks of igneous from those of sedimentary origin, and the relation of the saline constituents of ocean, lake, and river waters to the metamorphic processes. The laboratory methods described in the last part relate chiefly to methods of computation and to the construction of graphs, not to methods by which new chemical or physical data are obtained.

OUR BOOKSHELF.

Exercises in Practical Physics. By Prof. A. Schuster and Prof. C. H. Lees. Fourth Edition, revised. Pp. x+379. (Cambridge: At the University Press, 1915.) Price 7s. net.

THIS well-known text-book, the first edition of which was reviewed in NATURE of February 20, 1902, now appears in a revised form. A comparison between the present volume and an earlier edition shows few changes of great importance. Additional paragraphs have been supplied at the ends of some of the sections, but only a small part has been rewritten. A new section on the determination of dip by means of the dip circle is given in an appendix. A more drastic revision would have improved the book greatly, and brought it more into touch with modern methods. The increased use now made in physical laboratories of commercial ammeters and voltmeters would not be realised by a teacher depending only on this volume. We do not find a single exercise in connection with electrostatic measurements. In section lxvi. the Weston cell is now described as the standard cell, and all reference to the Clark cell is omitted; in the following sections, however, the Clark cell is still mentioned as the standard. In the measurement of wave-lengths, Rowland's table is referred to, but no mention is made of the new international scale of wave-lengths. In spite of its somewhat old-fashioned character, the book remains an excellent one both for the teacher and the advanced student.

Bacon's Sixpenny Contour Atlas. Northern Wales Edition. Pp. 41. East Anglia Edition. Pp. 41. South-west England Edition. Pp. 41. (London: G. W. Bacon and Co., Ltd., n/d.) Price 6d. net each.

THIRTY-SIX pages of coloured maps and an index to towns is certainly good value for sixpence. Four of the maps—communications, geological, relief, and vegetation—vary with the different editions. Of the others, twenty-five are contoured maps, on various scales, of different parts of the world, and the remaining pages contain nine maps of the world to show different distributions. The somewhat fantastic chart of geographical terms on the last page might well be replaced by another map. We feel also that the two-page introduction to the special maps would scarcely be intelligible to the children for whom this excellent little atlas is designed. The maps are clearly printed, and the colouring on the whole is good. It would be an advantage if the British Isles could be shown in relation to the Continental border of the North Sea, rather than as isolated islands, and if India could be shown on a larger scale. Most of the maps show no railways, but political frontiers are marked by dotted lines. The projection used is indicated on every map, and on a few England is shown on the same scale for purposes of comparison. This should be done on all the extra-European maps. The use of these atlases in lower forms would certainly be of assistance in the teaching of geography. R. N. R. B.

Termodinamik. By P. B. Freuchen. Pp. 143. (Köbenhavn: Lehmann and Stages Forlag, 1915.) No price.

THE scope of this little book is best indicated by the sub-title: "An outline of the history of thermodynamics and the significance of the two chief laws." In the preface the author declares his intention of tracing the development of thermodynamical ideas and their bearing on physics and chemistry. It is not a text-book, but rather a kind of thermodynamical "Who's Who"; successive short chapters deal with Carnot, Clapeyron, William and James Thomson, Robert Mayer, etc. One of these begins: "To read Planck's thermodynamical papers is to breathe pure, clear air."

The various parts of the subject are treated at unequal length; some, which are dealt with in the larger text-books of physics, are entirely omitted. Julius Thomsen's and Horstmann's work is described more fully, but like many other histories, this does not concern itself greatly with the recent past, so that Nernst's theorem occupies only half a page, and the quanta theory is referred to in a single sentence. Although unsuitable for beginners, the book should appeal to physicists, and particularly to chemists desirous of extending their outlook. Its publication in Danish speaks well for the scientific public of small countries, and we hope that by means of a translation it may become accessible to a larger number of readers.

G. B.

LETTERS TO THE EDITOR.

[The Editor does not hold himself responsible for opinions expressed by his correspondents. Neither can he undertake to return, or to correspond with the writers of, rejected manuscripts intended for this or any other part of NATURE. No notice is taken of anonymous communications.]

Scottish "Elephant" Designs.

with reply by G. E. Smith

PROF. G. ELLIOT SMITH has referred in NATURE of January 27 to the "conventionalised drawings of the elephant in . . . Scotland," and has been helped by these designs in his building up of an important theory. But, alas! these Scottish drawings are not of elephants.

I have gone most carefully into every known specimen, whole or fragmentary, of these so-called "elephants," for the purpose of attempting an elucidation and reading of the corpus of Pictish symbolism. They are invariably accompanied by other Pictish symbols. From consideration of their positions in series, their varying dimensions, the angles at which they lie, and other factors, I believe I have been able to arrive at a correct solution of the problem of their meaning. I am sure that they never had anything to do with elephants. But whether my solution is right or not, I merely here desire to point out that a close study of the drawings reveals that the supposed trunk consists of two elongated jaws. The other parts of the anatomy are likewise quite non-elephantine in character.

The fancied resemblance of these very early Christian sculpturings to elephant figures was first promulgated some forty years ago by a writer familiar with Indian mythology, who attempted to connect up Scottish with Indian inscriptions and designs. The attempt, however, was speedily abandoned.

LUDOVIC MACLELLAN MANN.

Royal Societies Club, February 1.

MR. MANN'S letter serves as a reminder that the discussion of the significance of the Scotch pictures of the elephant has followed a course remarkably analogous to that which has been waged for a century around the American representations of the elephant.

In both cases all the early scholars, as well as those of our contemporaries who do not claim to have a special ethnological insight, are satisfied to regard them as pictures of elephants; but the ingenuity of modern pundits insists on interpreting these sculptures in some more recondite way. In America the ethnologists are not sure whether the creature depicted was a tapir, a tortoise, or a macaw. In Scotland and Scandinavia the dispute around the elephant is maintained by scholars who are wrangling as to whether it is a walrus, a sun-bear, or a lion-rampant! (For the literature the reader should consult Haddon's "Evolution in Art," p. 194; the Earl of Southesk's "Origin of Pictish Symbolism," 1893; and Hildebrand's "Industrial Arts of Scandinavia," 1882.) Your correspondent tells us he has "been able to arrive at a correct solution of the problem," but with singular modesty he declines to tell us what it is.

In 1856 and 1867 the Spalding Club published two magnificent volumes dealing with "The Sculptured Stones of Scotland," in which the learned editor, Mr. John Stuart, brought his wide knowledge and common sense to bear upon the problems raised by the pictures of the elephant, and, I believe, settled the question for all time. He had no doubt whatever that the animal depicted was the Indian elephant, the knowledge of which "was brought into Europe by the Greeks after the Indian expeditions of Alexander the Great" (vol. ii., pp. xi. and xii.).

"The elephant of the Scotch stones cannot be regarded as a likeness but rather as a conventional representation of the animal, and the unvarying adherence to one form would suggest that the sculptors were unacquainted with the original and were not working from a traditional description . . . but rather were copying a figure with defined form" (p. xii). He adds further that the ornamental scrolls found on the elephant were not found on any other beast. These scrolls were derived from the Indian sea-elephant type of "makara."

Mr. Mann's remark that "the fancied resemblance of these . . . sculpturings to elephant figures was first promulgated some forty years ago by a writer familiar with Indian mythology," presumably refers to Col. Forbes Leslie, who, on the first page of his book on "The Early Races of Scotland," states that Mr. John Stuart's work "has been taken as the basis of the present work."

I presume, therefore, that Mr. Mann is not acquainted with the real evidence upon which my case is established.

There is, of course, a very considerable mass of other literature relating to these elephants, both serious argument and modern speculation; but the only other item that I need refer to now is an episode in one of the Norse fairy tales, as translated by Sir George Dasent, of "an old hag drawing water out of a well with her nose, so long was it."

One might make the same remark about this story as Mr. (now Sir) Edward Tylor made in reference to the American legend of the "great elk," told by Father Charleroix ("History of New France," 1744, vol. v., p. 187): "it is hard to imagine that anything but the actual sight of a live elephant could have given rise to this tradition" ("Early History of Mankind").

G. ELLIOT SMITH.

The University of Manchester, February 3.

The Remarkable Warmth of January, 1916.

A COMPARISON of the Greenwich temperatures for January, 1916, with past records may be of some interest.

Record temperatures for the time of year have occurred with considerable frequency this winter, and the warmth of January was unique in many respects. The maximum and minimum temperature observations taken at the Greenwich Observatory are used for the examination of the exceptional character of the month, and the Greenwich records afford trustworthy means of comparison extending over a long period.

The average temperature for January obtained from the maximum and minimum observations for the last seventy-five years is 38.5°, and the mean for January this year was 45.7°, which is 7.2° higher than the average, and it is 2.0° higher than in any January since 1841, the previous highest mean being 43.7° in 1846, which is followed by 43.5° in 1884. There have only been six previous Januaries in the last seventy-five years with the mean temperature as high as 43°. The mean of January, 1916, was 1.5° warmer than December, and 6.5° warmer than November last, whilst the month was warmer than in five Aprils during the last thirty years.

The mean maximum or highest day temperature for the month was 50.6°, which is 7.5° warmer than the average, and is 2.1° above the previous highest mean maximum, 48.5° in 1890, and there have only been four previous Januaries with the mean maximum temperature as high as 48°.

The mean minimum, or night temperature, was 40.8°, which is 7.0° above the seventy-five years' aver-

Temperature

age, and is 1.4° higher than the previous highest mean minimum, 39.4° in 1846, whilst there have only been three previous Januarys with the mean minimum as high as 39°. The mean minimum of 40.8° is in agreement with the average minimum at the beginning of May or end of October.

The lowest mean temperature for January during the last seventy-five years is 31.6° in 1879, and 31.8° in 1881, which, with January this year, gives a range of 14° for the possible mean temperature.

In January, 1916, there were three frosty nights at Greenwich, the lowest temperature being 29° on January 23, and in the last seventy-five years January, 1884, had only one frost, and January, 1872, had two frosts, whilst the other Januarys during the long period with as few as three frosty nights were 1851, 1853, 1875, and 1890. In twelve Januarys there have been as many as twenty or more frosts, and in 1879 there were twenty-six frosts. There has been no January with more than seventeen frosty nights since the memorable frost of 1895.

There were twenty days at Greenwich with the temperature 50° or above, and the nearest approach to this in previous Januarys since 1841 is seventeen days as warm as 50° in 1890, whilst there is only one other instance, in 1899, with as many as fifteen days as warm.

The highest temperature recorded at any time in January during the seventy-five years is 57° on January 28, 1843, and this temperature was reached both on January 1 and 17 this year. The two closing days of the month were the only occasions on which the maximum or highest day temperature was below the normal; the lowest maximum temperature was 42° on January 31.

There have only been two Decembers in the last seventy-five years with a higher mean than in January, 1916, the instances being 47.2° in 1852, and 45.8° in 1868, and in December, 1912, the mean was 45.7°, identical with last January. The only February with so high a mean was in 1869, the value being 45.8°.

Previous observations to those of the new series from 1841 made at Greenwich show a mean temperature of 44.6° in January, 1834, which is the highest during the last 100 years, and 1.1° lower than January, 1916.

CHAS. HARDING.

65 Holmewood Gardens, Brixton Hill.

is collected and washed with water, dried, and weighed. I found in 100 c.c. of liquid :—

Butter gr.	Margarine gr.	Sesame oil gr.
0.400	0.975	0.100
Planta (Vegetable butter) gr.	Klappa (Vegetable butter) gr.	Bran-butter (Vegetable butter) gr.
0.475	0.750	1.125
Butter-fat (Filtrated) traces	Olive oil (Sublime oil) traces	Arachis oil (Cold pressed) traces
Coconut oil (Raffinated) traces	Cod liver oil (Cold pressed) traces	

The first conclusion from these figures is that the seat of the lipoids in butter and butter substitutes is not the fat, but the solution with which it is mixed and emulsified.

Further, it is obvious that of the ±0.075 per cent. of lecithin in milk only a part is enclosed in the butter. The remaining lipoids in the skim milk are responsible for the greater part of the lipid content in margarine. Egg yolk, if added, may prove another source of lipoids in margarine. The high figure for margarine as compared with those for "vegetable butter" may be due to that source.

There is another store of lipoids in the seeds of plants, which is turned to profit in a recent Dutch patent process. There was a serious obstacle in the fact that lecithin enters into chemical combination (Hoppe Seyler, Juckenack), or absorption (Rob. Cohn), with albumins.¹ In order to set it free the seeds are treated with diluted acids or alkalis. "Bran-butter," e.g., is made by treating bran with diluted lime water. The solution thus obtained consists of water, gelatin, lipoids, and salts. With it a mixture of arachis oil and raffinated coconut oil is thoroughly emulsified. To this emulsion is added skim milk, and the butter separated after ripening. Working on these lines a vegetable butter with 1.125 gr. of lipoids in 100 c.c. could easily be obtained. By changing the proportions a higher content may be reached if desired.

It is obvious that a "vegetable butter" of this kind in its lipid content, and probably also in its vitamin content, is more than equal to butter. As a fact, it has a most marked advantage as a part of the daily diet.

Anyone interested in the process above mentioned and its possibilities as to making butter-like, and even cheese-like products, is invited to correspond with the writer.

Sneek, Holland.

J. DE RUITER.

Science Scholarships.

THE leading article in NATURE of February 17 (p. 671) quotes Dr. Shipley and Mr. Roberts, who say, in reference to the candidates for science scholarships at Cambridge:—"No candidate in natural science who reaches the necessary standard of ability is likely to be rejected. But the supply of candidates of sufficient ability is not so great as it should be."

I have not had the opportunity of reading the original letter, but this quotation contains two points on which I may be permitted to make a few remarks. I feel entitled to ask this privilege as between 1890 and 1904 I took a share in the work of scholarship examination, and I am now able to review my work in the light of a more general experience.

First, as to the type and standard of the questions that are set to the candidates, these appear now to

¹ The absorption of lipoids by albumins could be observed by heating sesame oil with bran to 100° C., by which the oil is proved to have lost half its lipid content.

Lipoids and Vitamines in Margarine and Butter.

IN the issue of NATURE of June 3, 1915, there is an interesting discussion on the presence of "vitamines" in butter and in margarine. The writer of the article on "Modern Substitutes for Butter" states that butter fat is the only fat or oil in which American investigators have shown the presence of vitamines, and he further states that vitamines are closely associated with lipoids, and that it is doubtful whether vitamines could be formed during lactic fermentation.

"S. H. B.," stating as a fact that vitamines are formed by lactic fermentation, concludes that butter and margarine, by being both churned with skim milk, should be equally rich in the precious substances mentioned.

Now there is no evidence about the quantities of vitamines in butter and in margarine. But recent investigations of my own throw some light on the quantities of lipoids in those substances, and with those lipoids the vitamines are closely allied. To find the lipid content, I proceed as follows:—The liquid fats, oils, butter, and margarine are shaken with an equal volume of hydrochloric acid (sp. gr. 1.19). After the separation of both liquids, part of the acid is let off and diluted with water. The precipitate of lipoids

Uleon margarine

be very much the same as those in the earlier period. The school science masters claim that they have adopted new methods of teaching. Secondly, as to the supply of candidates, I feel sure if consideration is taken of all classes of schools in the country it will be found that there is a very large number of boys keenly interested in science.

I will submit two suggestions. First, that closer touch with the local education authorities is necessary. Each local authority has a director or secretary who looks after the progress of the boys in his district. The directors are acquainted with the best boys through their local scholarship schemes, and should be able to point out at once the boys likely to make progress. Selection might in certain cases be made on their recommendation only. I will not go further into this means of connecting the universities and the schools, beyond saying that something of the kind exists in certain districts.

I believe that the present form of scholarship does not recommend itself to the less wealthy, and my second suggestion is that some scholarships might take the form of free places, to include education, board and lodging, and a small money grant. I find that the fear of unforeseen incidentals deters many from the thought of a career at Cambridge. The free place should remove this fear.

My experience leads me to think that a Cambridge career under such conditions would appeal to a very much wider field than at present.

SIDNEY SKINNER.

✓ Science in the Civil Service. *England*

I HAVE read with sustained interest your leading article on science in the public schools and the Civil Service. The preference given to classical subjects in the competitive examinations for higher appointments in the Civil Service is patent. This might be remedied, as you appear to suggest, by a different allocation of marks to the various subjects of the examination. But are there not serious objections to the whole system of competitive examinations as applied to these appointments? I venture to suggest that the system should be ended rather than mended—"off with his head," as the Red Queen would say, with admirable directness.

With your permission, I will briefly recapitulate the arguments for such drastic treatment, which I discussed in detail in a paper read at the Teachers' Guild annual conference in January, 1913. The system tends to impose upon universities and colleges an official or bureaucratic curriculum. In so far as it fails to do this, it divides the attention of the student between his university and an external authority. The result may be illustrated from the subjects selected at the competitive examination by the first successful candidate in 1911, representing a course of study which no university in the world would willingly impose upon its students:—English composition, French, mathematics, physics, logic and psychology, moral and metaphysical philosophy, political economy and economic history, and political science. The allocation of marks to various subjects and the arrangement of candidates in an order of merit on an aggregate of marks in a wide variety of subjects must be arbitrary and unscientific. No credit can be given for original literary or scientific work, and no provision is made for the specialisation of study which, within limits, may be desirable for the future work of the successful candidates. There can be no guarantee that various types of training are fairly represented among the successful candidates. Aptitude for administrative work is in no way specifically tested. The top candidate who, from the point of view of scholarship, may

be too good, and the last successful candidate, who may not be good enough, are equally accepted. Restricted age limits are a necessary condition of the system. It does not provide fairly for the promotion of men already in the Service. It is unsuitable for women, to whom the privilege of admission to higher appointments in the Civil Service will, without doubt, be more generally conceded in the near future. Indeed, the physical and mental strain which the system entails must be harmful to men in many cases. The need for expensive special preparation handicaps the poorer student. In practice, the system works unfairly as between the students of the old and the modern universities. This is notorious, but the figures for the five years 1906–10 may be quoted. Out of 473 successful candidates, 247 (more than half) came from Oxford, and 142 from Cambridge; only five came from London, two from Manchester, and one from Leeds.

A system of selection on record by a properly constituted board would meet all these criticisms, and might be applied also to the numerous professional appointments now made departmentally. Owing to the war, such a system is already in operation for a certain proportion of the appointments to the Indian Civil Service. I have not much doubt that if the public, as represented by the universities and the learned societies, were to ask for this reform it would be granted. There would not be much official opposition, for Mr. Leathes, the First Civil Service Commissioner, when asked by the Royal Commission on the Civil Service if, supposing all ideas of the misuse of patronage were excluded, the best way of appointment would not be by selection and nomination, answered in the affirmative, provided that you could trust your nominating authority to be not only absolutely honest, but also always industrious, and to have a highly developed judgment. He thought that then, ideally, selection would undoubtedly be superior, but feared that both history and experience had proved that it was an impossible way. The war has intervened since the pronouncement, and we are now, I hope, more disposed to suppress fears and prejudices in face of facts and arguments.

T. LL. HUMBERSTONE.

21 Gower Street, W.C., February 20.

The Place of Science in Education.

SIR EDWARD SCHÄFER will doubtless carry many with him in advocating a revolution in our educational system in favour of making science the foundation of the education given in our secondary schools. But the difficult question remains as to how that can be done. In the memorandum he refers to, a definite step was proposed towards the desired end. Sir Edward Schäfer considers it a halting step, but he does not suggest any alternative course whereby the public can be led to demand that its educational house should be put in order. As one who had some small share in drawing up the memorandum, may I ask Sir Edward Schäfer what course he would like to see adopted in place of the one already indicated? D. HILL.

11 Airlie Gardens, Campden Hill, W.

Latin as a Universal Language.

I HAVE read with interest the letter of Sir Lauder Brunton on Latin as a universal language. I sincerely hope the matter will not be allowed to drop. As a contribution, may I say that we have taught Latin here as a spoken language for fourteen years past, just as French and German are taught, and the

result is eminently satisfactory. The reality which is given to the study so quickens the boys' interest that their work is much better done, and about one-fifth of the time usually given to the study is enough to bring them up to the usual standard of the open scholarship examinations. But the chief benefit is the effect on ordinary boys in the earlier stages, who can take pleasure and pride in their work when they feel able to use it. We have "Latin teas," Latin plays, and if you choose to address them in Latin on the playing field they will be pleased to respond.

By this reform it is possible to meet the objections usually brought against Latin by scientific men; for it really does teach the language, and at a very moderate cost of time; in the first four years only three-quarters of an hour a day.

W. H. D. ROUSE.

Perse School House, Glebe Road, Cambridge,
February 16.

SUBMARINES.¹

THE author of "Submarines" is to be congratulated on having produced a well-written book upon a subject which has become of the greatest interest to a large world of readers. He tells us that this is not a technical book, and a doubt might arise lest it should in consequence be devoid of any clear or exact information, but this is not the case. The subject is so new and is so little understood that the excellent exposition of the whole subject to be found in the pages will, without doubt, command a large and immediate success. It would be difficult to expend the moderate price of 3s. 6d. to better account if making a present to any boy with an active mind, and the boy need not be so very young or the mind so very active—it is not written for boys—for the reader to be absorbed in interest.

The book is not technical, *i.e.*, difficulties of ship-building design, metacentric heights at different immersions are not considered. The peculiar difficulties in the design of engines are not discussed, though allusion is made to some of the peculiar features of the Diesel engine in particular. Neither the optical problem of the periscope nor its solution is explained in relation to its optical niceties, though, of course, it is discussed generally. These widely differing features are referred to as showing in what way the book is not technical, and for the general interest of the subject as a whole it is well that it is not technical, for there is abundance of interest in the twenty chapters as they stand, and a technical discussion of the numerous items which go to build up the modern submarine would be manifestly impossible. The writer of this notice would only remark in this connection that the account of the periscope would be improved if the optics were a little more fully indicated and if, in particular, the "all round eye" periscope invented by Mr. Funnell and worked out by Mr. Niblett and by Messrs. Aldis had its optical principle more clearly explained. There is an excellent photograph of the all round view taken, not at sea, but in the middle of a street, with a central circular empty patch in which it

¹"Submarines: their Mechanism and Operations." By F. A. Talbot. Pp. x+274 (London: W. Heinemann, 1915.) Price 3s. 6d. net.

NO. 2417, VOL. 96]

is proposed to present the direct ahead view on a larger scale (Fig. 1). There is a photograph of the peculiar and special all round lens looking something like a glass insulator for a piano castor, but it is impossible to see how it works, and the photograph of the admirable view obtained by its use makes the insufficiency of the description the more tantalising.

In a subject where there is so much secrecy it is somewhat surprising to find so much information with respect to the German submarines, but this the author obtained directly from the Krupp Company of Essen. He was also provided

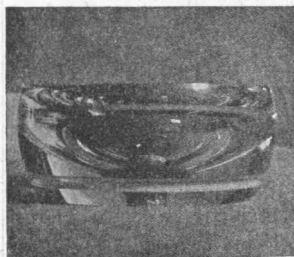

The lens unmounted.

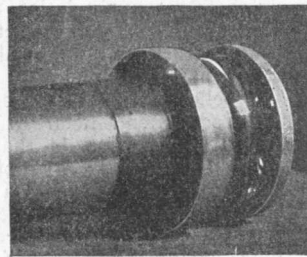

The lens mounted in its tube.

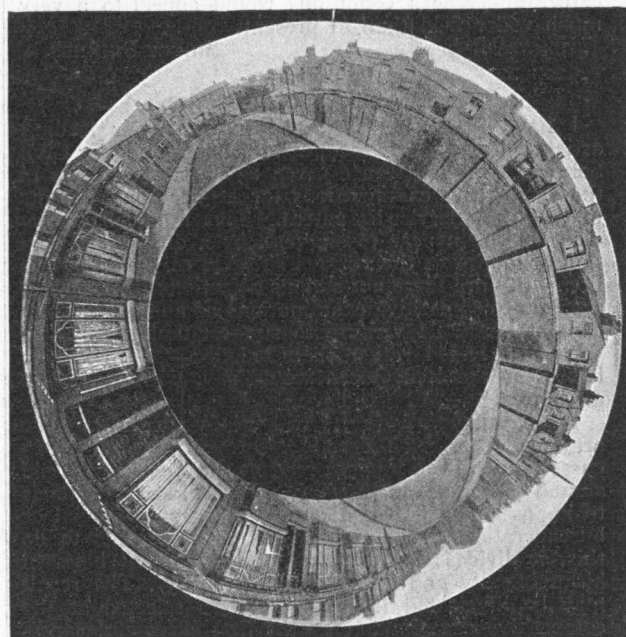

FIG. 1.—The wonderful "all-round view" periscope. The continuous view throughout the 360 degrees of the circle. From "Submarines," by F. A. Talbot. (W. Heinemann.)

with information by submarine builders in America, and from these and other sources he has been able to produce a large number of excellent pictures. It is satisfactory to know that the veil of secrecy surrounding the development of the submarine in this country appears to be unusually impenetrable.

The only misprint, or mis-writing of the nature of a misprint, is on p. 50, where the pressure of the sea-water at a certain depth is given as so many pounds per square foot instead of pounds per square inch.

C. V. BOYS.

Submarine boats

Submarine navigation

THE CALIPH'S LAST HERITAGE.

THIS book, of such manifold attractiveness and merit, has an unfortunate sub-title. For, though half the space is given to historical summaries (pp. 1-294), the really valuable part is mainly concerned with the author's travels in Asiatic Turkey in 1906-1913. The History begins with Cyrus the Great, and does not bring us to the Ottoman Turks until chapter xxv., p. 278. It is, therefore, really an historical survey of the lands now comprising the Turkish Empire in Asia for eighteen centuries before the appearance of the Ottomans, and during the first two centuries of Ottoman advance (to the death of Selim the Inflexible). Nearly all this survey is given to the times before the earliest Turkish attack upon our western world—before the advent of the Saljuks and their onslaught upon the Eastern Roman Empire in the eleventh century A.D. Some of the historic maps are well done, and the frontispiece (Restoration of the Round City of Mansur at Baghdad) makes a pleasing and suggestive picture, giving the real features of the Tigris capital of the Abbasids. But few, indeed, of these plans of past time have any reference to the Ottoman Turks.

We hope Sir Mark Sykes's interesting and valuable journeys may at some future time be separately issued in a somewhat shortened form. Certain portions of the diaries might be condensed considerably, but it is fortunate that the author has left the best of his narratives as they were written on the spot, at different dates.

"I have not endeavoured," he says, "to bring them into closer correspondence than they naturally bear to one another, and allowance must be made for modifications in the light of the events in the Ottoman Empire during these years."

These travels cover a very large part of Turkey-in-Asia. Syria, Mesopotamia, Kurdistan, Asia Minor—these are the chief fields; but Turkish Armenia is visited, and we have a short record of a journey in lower Egypt.

"The strategy pursued was to follow my nose over those portions of the map most rich in notes of interrogation and dotted lines."

¹ "The Caliph's Last Heritage: A Short History of the Turkish Empire." By Lieut.-Col. Sir Mark Sykes. Pp. xii+638. London: Macmillan and Co., Ltd., 1915. Price 20s. net.

The personal narratives of Sir Mark Sykes are written from the heart. They are full of vigour and reality, frequently touched with a sarcastic humour, often highly and truly picturesque, and constantly enlightening. They express incidentally the fierce revolt of a modern Western from "the great swindle of representative government, with its excluded merit, and its dingy, incompetent, greedy mediocrities who masquerade as the salt of the earth" (p. 528). For the Christian missions in the Turkish Empire the author has



Kastamuni Peasant showing Gallic type. From "The Caliph's Last Heritage."

little more affection than for representative government, "the prejudices of Clapham," or "the dogmas Brixtonian" (pp. 389-90). He shudders at "the American College in Beyrut, with its contused and brutish ornaments, its soul-less front," or at "the solid vulgarity of the Robert College, Constantinople—the incubators of all supposed to be fashionable and useful in modern Turkey." Particular reference may be made to the sketches of prosperous and progressive Aleppo and of the "magnificent race of people in the making to the east" (p. 298, etc.); to the account of Kastamuni, "perhaps the most beautiful city in all Northern

Turkey-Description and Travel

Asia Minor" (p. 383, etc.); and to the author's visitation of the Coptic monastery of St. Anthony near the Red Sea—a village of sixty houses, in two streets—with its gentle-eyed, hospitable, intelligent monks, and its gardens, guest-house, stores, stables, mill, swimming-bath, oil-press, and churches.

The reader should also turn to the studies of Arab and Kurdish humanity—the refinement and intelligence of the one, balanced by the simplicity, energy, and dare-devilry of the other; to the descriptions of the tumbled grandeur of the Alps of Kurdistan; and to the appendix on the Kurdish tribes, their distribution, numbers, and special features, past or present—this last an excellent piece of work. Finally, he may welcome the writer's appreciation of the merits of Muhammadan life and faith in Turkey, with its gleams of social religion "most admirable to me," of the reality and strength of Muslim devotion, and of the unconscious brotherhood of Islam (*e.g.*, pp. 383-5, etc.; 390; 523, etc.).

FRENCH VIEWS OF THE SYNTHETIC DYE PROBLEM.

IN a recent issue of the *Revue Scientifique* (January 8) Dr. Wahl, the director of the laboratory of the Poirrier works, who is already well known to English chemists as the author of a very readable text-book on organic dyestuffs, deals with the problem of the manufacture of these dyes in France.

In the historical summary of the causes which led to the decline of the dye industry in England and France, Dr. Wahl emphasises the importance of systematic scientific research as an aid to technical progress. This aid to the industrial chemist is illustrated by the work carried out by Hofmann at the College of Chemistry in London during the first twenty years of the youthful industry. An application to coal tar dyes of the purely scientific research on organic amines led to the discovery of Hofmann's violet and similar colours. The return of this scientific investigator to Germany in 1865 shifted the centre of gravity of the colour industry, for subsequently many of the master's German pupils also left the country and transferred to German factories the practical experience they had originally gained in English works. After a magnificent start the French dye industry came to a standstill, and this halt was prolonged by the disasters of the Franco-German war.

The next important development after 1870 was the production of acid azo-dyes, a discovery which was made simultaneously by French and German workers. In view of the immense range of possible combinations the French firm of Poirrier decided not to patent the new dyes, but in a few months Hofmann published in the *Berichte* the composition of the Poirrier oranges and their method of preparation. The systematic investigation of azo-dyes was a task admirably suited to the German temperament. The preparation and testing of the enormous number of possible

combinations required the collaboration of very large staffs of specially trained chemists, whose co-ordinated work on the extensive series of azo-dyes and their generators was a truly gigantic achievement.

This application of the attack by massed battalions to problems of industrial chemistry stood the German colour firms in good stead as other developments arose. For when the French chemist, Vidal, discovered his well-known sulphur black in 1896, the German factories immediately mobilised their armies of chemists and, in the Mackensen drive which ensued, they maintained a steady bombardment of two patents per week, in this class of dyes alone, for a period of eighteen months, with the result that the domain of sulphide dyes was practically annexed by the German colour-makers. This success has been repeated in many other branches of the colour trade, whole sections of which became German monopolies.

First among the scientific causes of this German predominance must be placed the rapid growth in the middle of the nineteenth century of the study of practical organic chemistry, and secondly we have the evolution of large technical laboratories having a scientific organisation of the highest order. Under the leadership of Bernthsen, Bohn, Duisberg, Sandmeyer, and others, continuity of effort, organisation of research, orderly arrangement of references and bibliography produced a sum total of intimate practical knowledge of the subject which could not have been gained in any other less methodical way. This co-ordination of effort in the German colour industry gives rise to 300 patent applications per annum, so that practically each day ushers in a discovery of sufficient importance to justify protection.

Among the commercial factors of this success the most striking is the employment by each German firm of a staff of technically trained representatives who visit the users of their products, demonstrating new methods of dyeing, anticipating the wants and difficulties of their clients, and collecting for their employers a valuable fund of information on the trading side of the business.

So much reliance is being founded in England on the prospects offered by a systematic boycott of German goods after the war that Dr. Wahl's views on this subject are worthy of note. As a professor of the beleaguered University of Nancy he can scarcely be suspected of pro-German bias, and yet he writes as follows:—

In order to sell, one must be prepared to offer the goods at a price equal to or lower than that of the competitors. For I do not think one should attribute to the question of sentiment an importance which it does not possess. If one may suppose that the unpopularity of our enemies will produce, after the war, a period of hesitation in the renewal of commercial relations with them, it would be presumptuous to think that personal interest will not, sooner or later, prevail over other considerations. It will then be essential to be in a position to offer the dyes at prices approximately equal to those quoted by the Germans.

In connection with the British scheme, it has recently been stated that "many hundreds of men, drawn from other occupations, have become chemical workers, and are making more money than they ever earned before." Although it is satisfactory to know that these new-comers in the dye field are already reaping a golden harvest, yet it must be admitted that the existing conditions are exceptional, even in an enterprise largely subsidised by the State. The ultimate justification of this good fortune will be the capacity to meet the foreign rival, whether German or American, with dyes of equal tinctorial value at even prices. As regards the French problem, Dr. Wahl is under no illusions as to an easy victory. He warns his compatriots that in this competition, as in the war, the essential requirements are stupendous efforts, much expenditure of capital, and even more of time.

1832-1916

SIR WILLIAM TURNER, K.C.B., F.R.S.

SIR WILLIAM TURNER, vice-chancellor and principal of the University of Edinburgh, died on Tuesday, February 15, in the eighty-fourth year of his age. His much-lamented death was unexpected. Almost to the day preceding the last illness he had been engaged in university duties, to which his whole life had been devoted. Although for several days previously he had been suffering from a recurrence of slight symptoms of gastric derangement, which for several years had been the one "thorn in the flesh" of an otherwise singularly strong and robust constitution, they had not prevented him from engaging in university work. A profuse gastric hæmorrhage, however, occurred early on Sunday morning, February 13, which produced collapse, soon followed by a painless oblivion, terminating in the final rest of death.

His record is a great one of services to his university and to the cause of education. A distinguished student of St. Bartholomew's Hospital, London, he went to Edinburgh on the invitation of the renowned Prof. Goodsir to assume the office of demonstrator of anatomy. So successful was he in this office and so meritorious were his early contributions to anatomical knowledge that on the death of Goodsir in 1867, he was, by universal approval, appointed to succeed him as professor of anatomy. He brilliantly justified expectation during his thirty-six years of tenure of the chair. Exact and methodical in his teaching, clear and emphatic in his statements to the useful extent of even being somewhat dogmatic, he proved a highly successful expositor of the subject. The anatomy department in his earlier professorial days had a preponderating share in medical education, and the number of students of anatomy was large. Turner's genius for organisation accordingly found ample scope in the arrangement for teaching. He remained professor for thirty-six years, and it is a melancholy recollection that as 1917 would have represented fifty years since he first became professor, former pupils were

already considering a jubilee celebration in his honour.

During the tenure of the anatomy chair Sir William Turner had shown, as a member of Senatus, so thorough a knowledge of university affairs, and, above all, so unequalled an ability to deal with financial problems, that he was an easy favourite for the principalship, in succession to Sir William Muir. He was appointed to this high office and also to that of vice-chancellor in 1903. The one reservation that found expression in some quarters was the possibility that he might exhibit a bias in favour of medical interests. He, however, assumed office with the declared intention of acting always in the best interests of all the faculties, and he loyally carried out this intention. A retrospect shows how wholeheartedly he furthered the well-being and success of all the faculties. He has left his impress on the development of each of them, which has been so gratifying in recent years. He was largely instrumental in establishing new professorships and lectureships, and in furthering tutorial instruction in arts and science. With unflagging energy and much tact he pioneered schemes for new buildings and new technical departments. On the site of the famous old infirmary, monuments of his untiring energy have been erected for science and arts, rivalling in some respects the palatial buildings devoted to medical education, erected while he was professor of anatomy.

Turner did not confine his activities to university affairs. In 1886 he was appointed member of the General Medical Council, of which body he remained a member for nearly twenty years. On the resignation of Sir Richard Quain in 1898 he was elected president of the council. This high office gave him full opportunity for displaying the qualities of tact, organising power, and familiarity with details, not less than the skill in reconciling conflicting interests, by which he was so conspicuously distinguished. As the mouthpiece of the council he conveyed to the Privy Council the views of the medical profession and the medical authorities on all questions of public and State importance, and thereby his influence on the well-being of the medical profession and on medical practice in the British Empire became a preponderating one. He successively occupied many other high appointments, such as those of president of the Royal Society of Edinburgh, of the Royal College of Surgeons, of the Royal Physical Society of Edinburgh, of the Anthropological section of the British Association, and of this Association itself on the occasion of its meeting in 1900.

Turner's business capacity led to his services being frequently in request on various committees and institutions affecting the public. Notwithstanding these many occupations, the almost unbounded vitality displayed during the greater part of life allowed him to do good and notable original work. He was one of the editor-founders of the *Journal of Anatomy* and a frequent contributor to its pages. His writings on anthropology and

craniology have a world-wide reputation, and the anatomy of the whale formed a favourite subject of research, in which he established a position as a great authority.

This unceasing activity in many spheres did not fail to bring recognition from numerous learned bodies as well as from the Crown. He was created a Knight in 1886, and in 1901 a K.C.B. His native town of Lancaster manifested the pride felt in his world-wide reputation by placing a commemorative tablet on the house in which he was born. Honorary degrees were almost showered upon him. He was an Honorary LL.D., D.C.L., D.Sc., and M.D. of one or other of almost every university in Great Britain and Ireland, and an honorary member of many academies and learned societies throughout the civilised world. It may be added that he was Honorary Lieutenant-Colonel of the Queen's Royal Volunteer Brigade, in the University Company, of which he was an original member at the beginning of the volunteer movement in the early sixties of last century.

Sheer ability and force of character were the weapons by which Turner carved his way to a distinction probably without parallel among his scientific and academic contemporaries. His strong personality gained for him success in the contests which could not be avoided in many of the interests and schemes he sought to advance. His honesty of purpose and soundness of judgment were always apparent, and much opposition was conciliated by his courtesy.

To many he was a dearly loved friend, whose constancy could always be relied upon. Originating, it may be, in the circumstance that both were Anglo-Scots, but probably even more because of the similar lines of biological research which early engrossed their thoughts, he formed a lifelong and very close friendship with Lister. The death of Lord Lister threw a light upon Turner's character and disposition by evoking outward manifestations of such suffering and pained emotion as even his intimate friends could not have anticipated.

How general was the affection and respect and admiration with which he was regarded was manifested in the ceremony which marked the closing of his career. A remarkably representative gathering assembled for the service in St. John's Church, preceding the interment in the Dean Cemetery, where many of his academic predecessors have their last resting place. It included the Lord Provost and Town Council of Edinburgh; the University Court, Senatus and Students' Union and Representative Council; the vice-chancellors and professors of the three other Scottish universities; representatives of the Universities of Oxford and London, of the Royal Societies of London and Edinburgh, of the Royal Scottish Academy and Geographical Society, of the Royal Infirmary, and of many other public bodies and institutions; while, also, Lord Kitchener, rector of the university, was represented by the Commander-in-Chief-in-Scotland.

NO. 2417, VOL. 96]

NOTES.

IN order to clear up any misunderstanding that may arise in consequence of recent legislation concerning reserved occupations, the Royal Society desires to point out that an unmarried chemist of military age entitled to exemption as an "analytical consulting or research chemist" should, unless he has been attested *before* March 2, lodge a claim for exemption with the local tribunal before that date. Men who have been attested should lodge their claims for exemption with the recruiting officer or local tribunal when called up for enlistment; and if such claims be not admitted, a communication stating all material facts in favour of the disputed claim should be addressed at once to the secretaries of the Royal Society, Burlington House, London.

WE learn with regret that Dr. P. Chappuis, the distinguished authority on gas thermometry, died at Basle on February 15.

MR. F. J. CHESHIRE, of the optical branch of the Ministry of Munitions, has been elected president of the Optical Society, in succession to Dr. W. Ettles.

THE death is announced, in his sixty-ninth year, of Dr. R. G. Alexander, consulting physician to the Royal Infirmary of Bradford and Halifax. Dr. Alexander was a pioneer in the advocacy of open-air treatment of phthisis and other complaints. He was the author of "Phthisis: its Prevention and Treatment," and of "The Art of Prolonging Life."

WE regret to note from the *Engineer* for February 18 the death, on February 13, of Mr. T. de Courcy Meade, the city surveyor of Manchester. Mr. Meade had held his post in Manchester since 1894; his most important work was concerned with the development of the new drainage scheme. He also rendered useful service in connection with the city's town-planning schemes and the reform of slum areas. He was a member of the Institutions of Civil and Mechanical Engineers, and also of several other engineering societies. An account of his work in Manchester is given in a paper which he read in 1914 before the Institution of Municipal and County Engineers.

LIEUT.-COL. STANLEY BOYD, senior surgeon to Charing Cross Hospital, passed away on February 1, after a short illness. He was educated at University College Hospital, and was appointed assistant-surgeon to Charing Cross Hospital in 1882, and was lecturer in anatomy in the school from 1888 to 1897. He was a sound teacher and a brilliant operator, and was particularly interested in the operative treatment of malignant disease. Stanley Boyd was a keen advocate of the claims of women to be educated for the medical profession, and much of the success of the Women's School was due to him. He held strong views on the university question in London, and was one of those who advocated the concentration of medical teaching in a few centres. At the time of his death he was chairman of the Board of Advanced Medical Studies of the University.

By the death of Lieut.-Col. J. W. Stokes, on February 10, the medical fraternity of Sheffield has suffered a great loss. While engaged in the arduous duties of a general practitioner in a highly populous district, he also acted as demonstrator in anatomy for many years in the University of Sheffield. His services in this direction were entirely voluntary, and were very much appreciated, owing to his regularity, punctuality, and the zeal with which he discharged his duties in the anatomical department. In addition to being a stimulating teacher, he helped materially to furnish the department with permanently mounted specimens, which were specially acceptable at a time when funds for equipment were very small. In his busy life he managed to find time to write on anatomical work, in addition to publishing papers dealing with medicine and surgery. His geniality and quiet humour, coupled with a frank, straightforward disposition, won for him great popularity with his colleagues and students alike.

THE Canadian Army Medical Corps has sustained a severe loss through the untimely death of Lieut.-Col. Bridge Yates. Born in Montreal in 1865, he was educated at Charterhouse and Cambridge University, after which he returned to Canada, graduating M.D., C.M., at McGill University. After graduating, he spent several months in Germany studying bacteriology, and on his return was appointed lecturer in bacteriology in McGill University. He early became interested in matters of public health, and in ambulance work. In recognition of his services he was appointed a Knight of Grace of the Order of St. John of Jerusalem, and later president of the Province of Quebec Branch of the Canadian Red Cross Society. He took an active part in the reorganisation of the Canadian Army Medical Corps, in 1907, and on the outbreak of war was appointed acting A.D.M.S. for the Montreal District. Col. Yates joined the McGill or No. 3 Canadian General Hospital in February, 1915, and organised the hospital buildings in France, where he contracted his fatal illness.

MR. J. B. JORDAN, news of whose death at Torquay on December 1, 1915, has just reached us, was for many years compiler and editor of the *Mining Record*, first at the Museum of Practical Geology and afterwards at the Home Office. He was, however, better known in the world of science as the inventor of the glycerin barometer, which has almost the range of the water barometer without its disadvantages. The readings of this barometer were for a considerable period published daily in the columns of the *Times*. He also devised a simple form of a photographic sunshine recorder; this was apparently suggested by an eccentric genius, a secretary of the Coal Commission, who used coconut shells for the purpose with approximately correct results. Mr. Jordan was also an expert modeller; one of the finest examples of his work in this direction is the model of the Southampton Docks executed for the London and South-Western Railway. Other works of his are a geological section showing the order, superposition, and approximate maximum thickness of sedimentary strata in the British Isles, a geological map of London on the scale of 6 in. to

one mile, based on Stanford's well-known map, and a model of London and its environs printed on tin and stamped in tolerably high relief, this last being a very ingenious, interesting, and useful map.

By the death of Col. C. Stonham, C.M.G., senior surgeon to Westminster Hospital, on February 1, we lose not only a brilliant surgeon, but one who distinguished himself in other ways. He was educated at University College Medical School, where he held the posts of demonstrator of anatomy and curator of the pathological museum, and became assistant-surgeon to the Westminster Hospital in 1887. In early life he was an enthusiastic mountaineer, and as a member of the Alpine Club made some noteworthy climbs. While busily engaged in hospital work and private practice he found time to make observations on bird-life, formed a rare collection of British birds and their eggs, and published his "Birds of the British Islands," notable both for the bird-lore contained in it and for the beauty of the illustrations. Col. Stonham commenced his military service as surgeon in the Middlesex Yeomanry, and in the South African war organised and took out as surgeon-in-chief the Imperial Yeomanry Field Hospital, and for his services in this campaign was made a C.M.G. He afterwards continued his ambulance work and organised a mounted ambulance unit, which was ready for active service on the outbreak of war. He was ordered to Egypt, where he became inspector of hospitals, but his health failed, and he had to return to Europe at the end of last year. A man of striking personality, his untimely death is a great loss to his profession.

FROM a letter to the *Times* of February 18, by Prof. J. Joly, it appears that experiments which he has carried out in collaboration with Prof. H. H. Dixon show that the undressed swimmer immersed in water at 8° C. loses heat from the surface of his body very nearly three times as fast as the dressed swimmer. The explanation is simple, since the clothing limits the mobility of the water, and it is the constant contact of fresh cold water with the surface of the body which conveys the heat away (by convection, not conduction). The experiments also show that the downward drag of ordinary clothing in sea-water amounts to no more than the weight of 4 oz., and this only after all the air has been expelled from the material. These facts seem to justify the opinion expressed by Prof. Joly, that when there is a probability of prolonged immersion the discarding of clothes is a drawback rather than an assistance, and that the only condition which justifies stripping is the necessity for rapid swimming. Probably the authors would agree that in any case boots should come off.

THE general restriction of imports of papermakers' raw materials brings into prominence our growing dependence upon half-manufactured materials, in this case the pulps or "half-stuffs." In adjusting the incidence of the restriction to the various sections of the industry, it is to be noted that the proportion of labour and capital earnings and charges will be relatively less in the case of materials which work up such half-stuffs. On the other hand, the esparto mills are equipped for preparing and boiling the grass, and

for recovering the soda ash used in the boiling, which gives a very different figure for mill costs per ton of output. As to a possible supply of indigenous fibrous material in substitution of the material to be excluded under this order, the only one practically available at the moment is straw. Straw was at one time quite a staple raw material, and was very largely worked at mills favourably situated in agricultural districts. The chemical treatment of straw for producing a bleached half-stuff (cellulose) is closely similar to that of esparto, but it requires a more severe boiling treatment, and the yield of cellulose is much less. Further, from its structural features, it cannot be economically or conveniently handled in the preparing and boiling plant of esparto mills. There is, however, a possibility of adapting this plant to the exigency.

A MEMORIAL has been presented to the Prime Minister and the Chancellor of the Exchequer, signed by many persons of influence, and among them by a considerable number of scientific and professional men and educationists. Its purport is to give emphasis to the demand for national economy, and to urge the necessity of retrenchment in official and municipal expenditure. It recognises that the national finances and the enormous demands made day by day in the prosecution of the war will render necessary heavy additional taxation and much larger savings, both by public bodies and private individuals, than have hitherto been effected. For the latter purpose authoritative guidance from his Majesty's Government is much to be desired. It is suggested, therefore, that a strong official War Savings Board should be constituted, which should lay down regulations for enforcing economy on Government Departments and on public authorities during the period of the war, and should also consider and report on the best means of advising and encouraging domestic thrift. It urges that these measures should be adopted without delay. The memorialists are no doubt addressing persons who will be in full sympathy with their objects. For ourselves we should have been disposed to add to the weighty considerations they have brought forward the importance of that other branch of thrift, which consists in judicious expenditure, and in applying to the best purpose the money which is being lavishly expended directly on the operations of the war, and indirectly on a great variety of objects more or less concerned with the war.

THE danger of relying on popular tradition in questions of archæology is illustrated by a recent case reported by the American Bureau of Ethnology. For many years the people of Georgia have believed that the Nacoochee Mound in White County dated back to the Spanish conquest, and was closely connected with a beautiful local legend. Mr. F. W. Hodge, who has recently excavated the site, finds that the word Nacoochee cannot be traced in the Cherokee language, and that it does not, as has been claimed, mean "Evening Star," a theory on which the legend was based. The mound is really of comparatively recent origin, was constructed by the local Cherokee

Indians, and was in use by them until the nineteenth century.

STUDENTS of clan organisation based on the totemistic crest system will be interested in a careful study published as Bulletin No. 19 of the Department of Mines, Canada, which contains an account of the social organisation of the Nass River Indians, by Mr. E. Sapir. This tribe is divided into four exogamous phratries with maternal descent—that is to say, the crests and other privileges descend from a man to his sister's son, and a man's predecessor as the holder of any title or right is not his father, but his maternal uncle. These phratries are again divided into clans, each with a definite order of rank marked by the ownership of special crests, legends, songs, individual names, houses, hunting, and fishing territories, and numerous other inheritable privileges.

At the monthly general meeting of the Zoological Society of London, held on February 16, it was announced that fifty-seven additions had been made to the society's menagerie during the month of January. The most notable of these were a specimen of Pere David's deer (*Elaphurus davidianus*), now extinct as a wild animal, and an Anoa (*Anoa depressicornis*), presented by the president, and two Argentine frogs (*Leptodactylus mystacinus*) and six South American sand toads (*Bufo arenarum*), new to the collection, presented by Mr. Wilfred Smithers. As compared with the month of January, 1915, there was an increase in the number of visitors of no fewer than 14,407, while the receipts showed an increase of 269l.

MISS L. H. HUIE makes an important addition to our knowledge of the parasitic Anthomyiid fly, *Hylemyia grisea*, in the *Scottish Naturalist* for January. Of the life-history of this insect little was previously known. Miss Huie now describes its method of oviposition in the burrows of the wild bee, *Andrena analis*. The larva, on hatching, makes its way to the brood chamber to feed upon the pollen stored for the larval bee, the fate of which in these circumstances has yet to be traced. The author in this communication not only adds materially to our knowledge of this insect, but she also, for the first time, records its presence in Scotland, where hitherto it has not been supposed to occur. In the same number Miss L. J. Rentoul and Miss E. W. Baxter record some useful notes on the moulting of birds in their winter quarters. While adopting the latest eccentricities of nomenclature in regard to the species described, the authors have neglected to acquaint themselves with the morphological terms which have been in use for the last twenty years or so in regard to the plumage.

THE January number of the *Zoologist* contains a valuable summary of the fishing industry at Great Yarmouth, by Mr. A. H. Patterson. The influence of the war is manifest on nearly every page of this report. Among other matters, it is mentioned that in consequence of the diminished fish supply dogfish are now esteemed as food-fishes, large quantities being now eaten locally with relish. The record catch of herring for a single boat was landed on November 1.

PETROL GAS FOR COUNTRY LABORATORY GAS SUPPLY.

PETROL GAS as a laboratory supply is practically indistinguishable from ordinary coal gas. It is burnt in the usual laboratory apparatus, bunsen burners, &c. The management of the generator consists in periodically winding up a weight (usually once a day), which operates a small plant automatically on the principle of the grandfather's clock. No skilled supervision whatever is required. The gas is always ready at any time of the day or night. The running cost is equivalent to coal gas at 3/- per 1000 cubic feet. The gas is equally efficient for lighting and heating (separately or together.)

SOME INSTALLATIONS.

THE LABORATORY, COLLEGE OF AGRICULTURE,
HOLMES CHAPEL, CHESHIRE.
" " ADDINGTON PARK HOSPITAL,
NEAR CROYDON.

GOVERNMENT LABORATORIES (THREE).

THE CLINICAL LABORATORY, YELVERTON, DEVON.
THE ROYAL HORTICULTURAL SOCIETY'S LABORATORIES,
WISLEY, SURREY (in course of execution).
SEALE HAYNE AGRICULTURAL COLLEGE, NEWTON
ABBOTT (in course of execution).

All particulars, prices and inclusive estimates free from the Makers.

THE COUNTY LIGHT, Ltd.,

ST. STEPHEN'S HOUSE, WESTMINSTER, S.W.

Installations carried out in any part of the Country.

Hopkin and Williams, Limited

16 CROSS STREET, HATTON GARDEN, LONDON, E.C.

Works: Ilford, Essex.

Telegrams: "Cerium, London."
Telephone: 604 Holborn.

Branch House of Howards & Sons, Ltd., Stratford and Ilford.

MANUFACTURERS OF GUARANTEED CHEMICAL REAGENTS

For ANALYSIS and RESEARCH

Made and supplied to standards and specifications described in the recent publication

"Analytical Reagents: Standards and Tests."

Compiled by EDMUND WHITE, B.Sc. (Lond.), F.I.C.

The first edition of this book was published in 1911 in order that Chemists might procure these materials to a definite specification of purity. The manufacture of Reagents was thus placed on a permanent basis in this country five years ago by HOPKIN & WILLIAMS, LTD., and the firm have received many indications of appreciation from their clients all over the world.

SECOND-HAND SCIENTIFIC BOOKS

J. W. Griffiths. "Microscopic Dictionary," with plates, 1855	£3 3 0
A. C. Cole. "Studies in Microscopical Science," Vols. 1, 2, 3, 4, half calf, with 72 specimens	3 10 0
G. Johnston. "History of British Zoophytes," 1847, 2 vols.	1 0 0
A. Pritchard. "Microscopic Cabinet," 1832	0 12 6
"Natural History of Animalcules," 1834	0 7 6
Stephenson and Churchill. "Medical Botany," 2 vols.	0 15 0
A. Smee. "My Garden: Its Plan and Culture," with description of its geology, botany, and natural history	0 12 6
Caxton Press. "The Book of Nature Study," 6 vols.	2 0 0
Hardwicke's "Science Gossip," from 1865-1892, 14 vols., half calf	4 10 0
E. Forbes. "History of British Starfishes"	0 7 6
Sir C. W. Thompson. "The Voyage of the 'Challenger'—The Atlantic," 2 vols.	0 15 0
"The Monthly Microscopical Journal," from 1869 to 1877, handsomely bound half calf	4 10 0
"Quarterly Journal of Microscopical Science," 1865 to 1868, 2 vols., half calf	0 18 0

C. BAKER (Estab. 1765), 244 High Holborn, London.

RARE BOOKS.—The Ibis, 1904 to 1908, 5 vols., £4 4s., cost over £8;

Anderson Anatomical and Zoological Researches, Yunnan Expeditions, 2 vols, 1878, £3 3s.; Newton's Dictionary of Birds, 10s. 6d., pub. 30s.; Hewitson's Eggs of British Birds, 2 vols., 1846, £3 3s.; Another copy, 1856, £4 4s.; Pettigrew-Design in Nature, 3 vols., 1908, 18s. 6d.; Hulme's Wild Fruits of the Countryside, 6s. 6d.; Cox's Sanctuaries and Sanctuary Seekers of Mediæval England, 6s. 6d.; Conder's Rise of Man, 4s. 6d.; The Childhood of Man, by Leo Frobenius, trans. by A. H. Keane, with 415 illus., 6s. 6d., pub. 16s.; Sex Mythology, including an account of the Masculine Cross, 6s.; Morris, Natural History of Moths, 1894, 4 vols., £2; Morris, British Birds, 6 vols., £3 10s., 1860; Sach's Physiology of Plants, 1887, £2 2s.; Untrodden Fields of Anthropology by a French Army Surgeon, 2 vols., curious plates, £5 5s.; Nordau's Paradoxes, 4s. 6d.; Nordau's Interpretation of History, 3s.; Galton Memories of My Life, 4s. 6d.; Galton's Record of Family Faculties, 1884, 35s.; Galton's Inquiries into Human Faculty, 1883, 35s.; Galton's Hereditary Genius, 1869, 28s.; Fox-Davies' Book of Public Arms, last edit., 35s.; Encyclopedia Britannica Atlas, 1902, 25s. net for 7s. 6d.; Cust's Life Benvenuto Cellini, 2 vols., 12s. 6d.; Davey's Flora of Cornwall, 4s. 6d.; Who's Who, 1915, 5s. 6d.; Scherren's Zoological Socy. of London, coloured plates, 10s. Collections of Valuable Books purchased Rare and Out of Print Books supplied. State Wants.—BAKER'S GREAT BOOKSHOPS, 14 and 16 John Bright Street, Birmingham.

"POSTLIP"

ENGLISH FILTER PAPERS

Manufactured in annually increasing quantities for upwards of 50 years.

All sizes in squares and circles.

Rolls made to order.

Several new grades are now successfully replacing the best German makes.

See Report of tests made by THE NATIONAL PHYSICAL LABORATORY, a copy of which will be sent on application to

**EVANS, ADLARD & CO., Ltd.,
POSTLIP MILLS, WINCHCOMBE.**

Ask your Laboratory Furnisher for samples of "Postlip" Filter Papers.

MACMILLAN'S FIRST BOOKS OF SCIENCE.

GLOBE 8vo. ILLUSTRATED. 1s. 6d. each.

A First Book of Arithmetic. By S. LISTER, B.Sc., Senior Mathematical Master, The County School, Uxbridge.
266 pp.

A First Book of Geometry. By J. V. H. COATES, B.Sc.(Lond.), Assistant Master, Alley's College, Dulwich.

A First Book of Practical Mathematics. By T. S. USHERWOOD, B.Sc., Wh. Ex., A.M.I. Mech.E., and C. J. A. TRIMBLE, B.A.

A First Book of Physics. By L. LOWNDS, B.Sc.(Lond.).

A First Book of Experimental Science. Arranged by W. A. WHITTON, M.Sc. From "Lessons in Science," by Prof. R. A. GREGORY and A. T. SIMMONS, B.Sc.

A First Book of Chemistry. By W. A. WHITTON, M.Sc., Science Master, Holloway County School, London.

A First Book of Botany. By ELIZABETH HEALEY, Assoc. of the Royal College of Science, London.

A First Book of Nature Study. By E. STENHOUSE, B.Sc.(Lond.).

A First Book of Zoology. By T. H. BURLAND, M.A., B.Sc.

A First Book of Physiology and Hygiene. By GERTRUDE D. CATHCART, M.B., B.Sc.(Glas.), D.P.H.(Camb.).

A First Book of Rural Science. By J. J. GREEN, B.Sc., Lecturer in Agriculture, Devon County Council.

A First Book of School Gardening. By ALEXANDER LOGAN.

A First Book of Commercial Geography. By T. ALFORD SMITH, B.A., F.R.G.S., Senior Geography Master, St. Dunstan's College, Catford.

A First Book of General Geography. By B. C. WALLIS, B.Sc. (Lond.), F.R.G.S.

A First Geography of the British Isles. By W. MACLEAN CAREY, M.A., B.Sc., Author of "A First Book of Physical Geography," &c. With Coloured Maps, and Illustrations.

A First Book of Physical Geography. By W. MACLEAN CAREY, M.A. (Cantab.), B.Sc.(Lond.), Second Master of Rutlish Secondary School, Merton.

A First Book of Geology. By ALBERT WILMORE, D.Sc.(Lond.).

MACMILLAN'S READABLE BOOKS IN NATURAL KNOWLEDGE.

FULLY ILLUSTRATED. 1s. 6d. each.

The Changeful Earth. An Introduction to the Record of the Rocks. By Prof. GRENVILLE A. J. COLE, M.R.I.A., F.G.S.

The Past at our Doors, or The Old in the New Around Us. By W. W. SKEAT, M.A.

Wonders of Physical Science. By E. E. FOURNIER, D.Sc.

Tillers of the Ground. By MARION I. NEWBIGIN, D.Sc.

Threads in the Web of Life. By MARGARET and Prof. J. ARTHUR THOMSON.

Achievements of Chemical Science. By Prof. JAMES C. PHILIP, M.A., D.Sc.

MACMILLAN & CO., LTD., LONDON.

MACMILLAN & CO.'S NEW BOOKS.**The Tribes and Castes of the Central Provinces**

of India. By R. V. RUSSELL, of the Indian Civil Service, Superintendent of Ethnography, Central Provinces, assisted by RAI BAHADUR HIRA LAL, Extra Assistant Commissioner. Published under the Orders of the Central Provinces Administration. With Maps and Illustrations. In 4 vols. 8vo. 42s. net.

Historical Introduction to Chemistry. By T. M. LOWRY, D.Sc., F.R.S.

Illustrated. Crown 8vo. 597 pp. 8s. 6d. net.

THE NEW WITNESS.—"Dr. Lowry has prepared a most useful book. It is not a formal history of chemistry. It is not a biographical dictionary of chemists. It is an historical account of the more important facts and theories of chemistry as these disclosed themselves to original workers."

FOURTH EDITION NOW READY.

The Gases of the Atmosphere, the History of their Discovery. By Sir WILLIAM RAMSAY, K.C.B., F.R.S., Officier de la Legion d'Honneur,

Emeritus Professor of Chemistry in University College, London. Fourth Edition. With Portraits. Extra crown 8vo. 6s. net. *NATURE.*—"Just complaint has been made recently in 'Nature' of the dearth of good modern popular or semi-popular literature calculated to inform the public of the methods and achievements of natural science. Nothing could be better for this purpose than Sir William Ramsay's book on 'The Gases of the Atmosphere,' for here we have a first-hand account of modern discoveries in a connected and highly interesting narrative, and presented in a sufficiently elementary style to make the subject intelligible to a large reading public."

NEW EDITION, COMPLETELY REVISED, WITH NEW CHAPTERS ON WIRELESS TELEGRAPHY, AND THE MODERN CONCEPTION OF THE ELECTRON.

Elementary Lessons in Electricity and

Magnetism. By SILVANUS P. THOMPSON, D.Sc., B.A., F.R.S., Principal of and Professor of Physics in the City and Guilds of London Technical College, Finsbury. New Edition completely revised and in many parts re-written. Illustrated. 760 pp. Fcap. 8vo. 4s. 6d.

Elementary Lessons in Sound. By D. E. JONES, B.Sc., lately Professor of Physics in the University of

Wales, Aberystwyth. Illustrated. Globe 8vo. Sewed. 1s.

THIRD EDITION, THOROUGHLY REVISED.

Elementary Applied Mechanics. By T. ALEXANDER, C.E.,

M.Inst.C.E.I., &c., and A. W. THOMPSON, D.Sc., &c. With numerous Diagrams, and a Series of Graduated Examples carefully worked out. Third Edition. 8vo. 15s. net.

Mathematical Papers for Admission into the Royal Military Academy and the Royal Military College.

September–November, 1915. Edited by R. M. MILNE, M.A., Assistant Master, Royal Naval College, Dartmouth, &c. Crown 8vo. Sewed. 1s. net.

The Mathematical Theory of Probabilities and its application to Frequency Curves and Statistical Methods.

By ARNE FISHER, F.S.S. Translated and Edited from the Author's original Danish Notes with the assistance of W. BONYNGE, B.A. With an Introductory Note by F. W. FRANKLAND, F.I.A., F.A.S., F.S.S., &c. VOLUME I. MATHEMATICAL PROBABILITIES AND HOMOGRADE STATISTICS 8vo. 8s. 6d. net.

The Treatment of Acute Infectious Diseases.

By F. S. MEARA, M.D., Ph.D., Professor of Therapeutics in the Cornell University Medical College in New York City. &c. 8vo. 15s. net.

Keeping Physically Fit. Common-Sense Exercises for the whole Family. By W. J. CROMIE, Instructor in Physical Education, University of

Pennsylvania, &c. With Illustrations. Crown 8vo. 4s. 6d. net.

BOOK IV. JUST PUBLISHED.

Macmillan's Geographical Exercise Books.

With Questions by B. C. WALLIS, B.Sc., F.R.G.S. Sewed. I. THE BRITISH ISLES. 6d. Key. 2s. 6d. net. II. EUROPE. 6d. Key. 2s. 6d. net. III. THE BRITISH EMPIRE. 6d. IV. THE AMERICAS. [I–IV. Ready.] V. ASIA AND AUSTRALASIA. [In the press.]

A.M.A. CIRCULAR.—"A valuable help to the teaching of geography."

Alcohol and the Human Body. An Introduction to the Study of the

Subject, and a Contribution to National Health. By Sir VICTOR HORSLEY, F.R.S., and MARY D. STURGE, M.D. With a Chapter by ARTHUR NEWSHOLME, M.D., and a Chapter written in collaboration with Sir LEONARD ROGERS, K.C.I.E. Fifth Edition. Globe 8vo. 1s. net.

MACMILLAN AND CO., LTD., LONDON.

Bausch & Lomb PHOTOMICROGRAPHIC CAMERA

Model H

Designed for medium power work in any laboratory, and has long demonstrated its general efficiency and convenience for such purposes. Its features include:—

Heavy Base, $13 \times 9\frac{1}{2}$ in. **Adjustable Plate**, 8×6 in., to carry microscope.

Graduated Optical Bed, $25\frac{1}{2}$ in. long, carrying camera parts.

Inclination Joint, permitting optical bed to be adjusted at any angle between horizontal and vertical.

Adjustment of Camera Supports to align with microscopes of different dimensions.

The two camera supporting frames are clamped to the optical bed and carry a bellows long enough to accommodate work at any distance along the bed. The first frame carries the front board with tube adapter for the microscope, or a shutter and this adapter.

The rear frame carries a plate holder box with a hinged cover at the back and two springs permitting the plate holder to be laid in place and then gently but firmly pressed into exact position. The focussing screen of ground glass with clear centre slides in two grooves in the camera box.

The microscope plate has a movement of $4\frac{1}{2}$ in., permitting the microscope to be removed from the optical centre for examining a slide and quickly replaced. The adjustments on the plate will accommodate **any standard microscope**.

Price, without Shutter, £9 7 6

Inspection invited at our Showrooms, or List "C-c 1" sent post free.

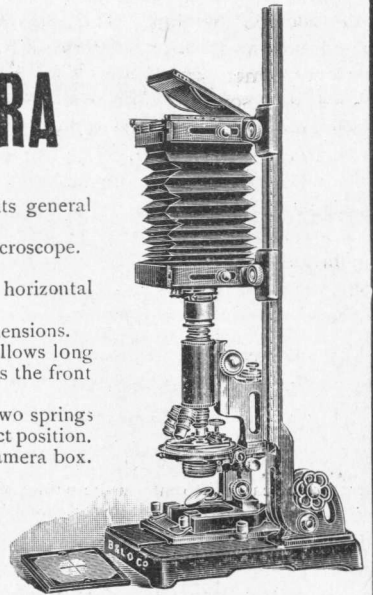

Also LARGE PHOTOMICROGRAPHIC APPARATUS, MICROSCOPES (over 109,000 sold), MICROTOMES, PROJECTION and DRAWING APPARATUS, CENTRIFUGES, VISCOSIMETERS, etc.



TRADE MARK.

Bausch & Lomb Optical Co.

Contractors to British, Indian, Colonial, and Foreign Governments,

37-38 HATTON GARDEN, LONDON, E.C.

Or through all Dealers.

Factory: Rochester, U.S.A.

Flat Cutting Rocking Microtomes

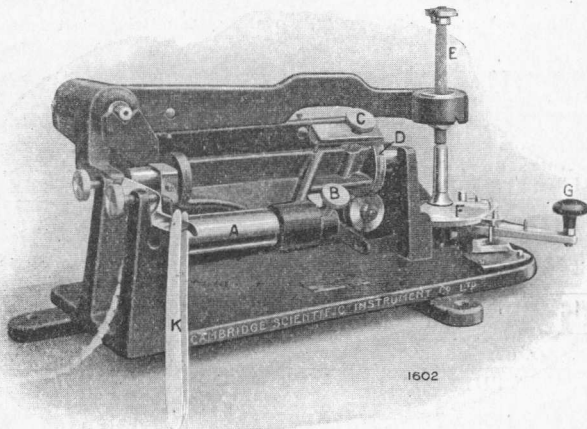

These Microtomes are designed to cut sections from a perfectly flat surface. Sections of thickness from '002 mm. to '015 mm. can be obtained from objects up to 30 mm. in diameter. The instruments are simple and rigid in construction, permit of rapid working, and give uniform and accurate sections.

Full description in List No. 130 N, which will be sent on request.

**THE CAMBRIDGE SCIENTIFIC INSTRUMENT CO., Ltd.,
CAMBRIDGE, ENGLAND.**

This was made by a Scotch boat, and represented some 280,000 herring. The Scotch vessels, indeed, earned enormous sums. While most of the fish taken were consumed at home, some were exported to France, and some to the United States. The Norfolk mussel industry has profited by the suspension of imports from Holland. During the season 87,500 cwt. were taken from the beds of the Boston and Lynn fisheries. The latter were raided by starfish of large size, and "small starfish . . . did much mischief to the brood muscles." This much may be gathered from the fact that as many as two and a half tons of these pests have been taken in one day.

THE improvement of tobacco cultivation in Bihar is one of the subjects which has engaged the attention of Mr. and Mrs. Howard, at the Agricultural Research Institute, Pusa, and their account of the industry with their conclusions is published as Bulletin No. 50, 1915, from the Pusa Institute. Attention at Pusa has been mainly concentrated on the improvement of indigenous varieties of tobacco, and a type has been discovered of light colour and good texture suitable for cigarette tobacco. Green manuring with Sunn hemp has also been found valuable on light, high-lying, well-drained soils. The importance of growing only one kind of tobacco and of growing even fields of the crop is insisted upon, the value of a single variety being evident since cross fertilisation is common in tobacco. The bulletin contains full particulars as to seed sowing, transplanting, manuring, and the principles of curing, for it is largely on the curing that the value of the tobacco depends.

PROF. BAYLEY BALFOUR describes fifty new species of *Primula* from China, Tibet, and the Himalaya in Notes from the Royal Botanic Garden, Edinburgh, vol. ix., No. xli. The Chinese and Tibetan species are from the collections recently made by Mr. G. Forrest and Mr. F. Kingdon Ward in particular, and Prof. Balfour deals critically with the micro-forms found in several of the Chinese species. A few species described have been collected by Mr. Reginald Farrer, and some also by Mr. Purdom. Among those of more particular interest may be mentioned *Primula also-phila*, Balf. fil. and Farrer, found in the highest woodland zone of the Tibetan forests, with long, creeping stolons running in the moss in which it grows. These stolons are traversed by a fungous mycelium, as is the case with the *Pyrolas*, among which this species grows, and no doubt through its guest fungus it is capable of absorbing the atmospheric nitrogen. Another striking species is *P. Viola-grandis*, Farrer and Purdom, from Kansu, belonging to the section *Omphalogramma*, the section bearing irregular flowers. This plant has thick flannel-like leaves and large pale-purple flowers, the three upper lobes lying back over the long tube and the three lower standing out stiffly, like those of a violet. Five other species of this section are known, and Prof. Balfour inclines to the view that this section should be placed in the genus *Bryocarpum* rather than in *Primula*.

To assist farmers to rear a larger number of calves and ultimately to increase our food supplies, the West

of Scotland Agricultural College has recently carried out a series of calf-feeding experiments at the college farm, Kilmarnock. The report on these experiments by Mr. William G. R. Paterson and Mr. Lindsay Robb is issued as Bulletin No. 68. Four different rations were tested, viz.:—(1) Whole milk; (2) separated milk and crushed oats; (3) separated milk and maize meal; and (4) whey and a special calf meal. The value of these diets, as judged by the average weekly live weight increase of the calves in each group, came out in the order given, but the cost per lb. increase with whole milk was 7.0d., against 3.5d. for separated milk and either crushed oats or maize meal. The whey ration was not a success. The calves did not like it, and it had a tendency to scour them. The lot fed on whole milk were naturally the best-looking all through the experiment, but the crushed oats group were very little behind. The trials showed that separated milk with either crushed oats or maize meal make suitable and economical rations for calves. It is advisable to feed solely on whole milk for the first four weeks, and to effect the change of ration gradually. These Scotch experiments make an interesting comparison with similar trials carried out by Dr. Voelcker at Woburn in 1912-14. Here the records were continued right up to the slaughter of the animals as two-year-old bullocks, and demonstrated in a striking way the superiority of crushed oats over all the other rations tested.

In a recent note we remarked on the energy shown in America in the investigation of the problems of protozoa in the soil. Vol. v., No. 11, of the *Journal of Agricultural Research* contains a paper on the relative activity of protozoa in greenhouse and field soils. Mr. G. P. Koch has examined a number of soils in the endeavour to ascertain whether protozoa lead an active life in soils of different moisture content when the temperature is constant and when it is variable. The soil is stirred with a few drops of sterile water and examined under the microscope for two minutes only, thus avoiding errors due to rapid development of encysted forms, as pointed out by Martin and Lewin. According to the author, active protozoa do exist in greenhouse soils, but in very limited numbers, only six out of twenty soils examined showing a few trophic forms. Active protozoa are not found in field soils under normal conditions, but cysts invariably occur which become active in a favourable environment. The moisture content of the soil appears to be the chief factor in determining the presence or absence of active protozoa, while temperature, organic matter, and physical structure are of secondary importance. After heavy rain, when the soil is waterlogged, protozoa excyst and can be found in the active state in standing water. The time required for excystment was found to be longer than that given by previous workers. Small ciliates can excyst in one to two hours at 23° C.; at this temperature flagellates require six to eight hours and large ciliates forty hours. Both moisture and temperature appear to influence the period of excystment. Evidently the two-minute period of examination of each sample is well on the safe side. The author concludes that protozoa are too rarely

active in field soils to operate as a limiting factor in crop production.

EARTHQUAKES are not frequent in West Africa, but that they are not exceptional is the contention of M. Henry Hubert, who has a paper on the subject in *La Geographie* for November, 1915 (vol. xxx., No. 5). From the information he has collected, which he admits is incomplete, it appears that the region in which earthquakes are most likely to occur is between longitudes 4° and 6° W., which coincides with an area of highly folded metamorphic rocks. The earthquakes are seldom violent, but have been known to reach eight on the scale of De Rossi.

TIDES tables for the eastern coasts of Canada and for the Pacific coast for 1916 have been received from the Department of the Naval Service of the Dominion of Canada. It is claimed that, on the basis of length of observation, the tables for the majority of the western ports of Canada are superior to those of any port on the Pacific coasts of America, Asia, or Australia. The tables for Prince Rupert are equal to those for San Francisco, which are based on the longest record of any published for the Pacific coast by the United States Coast Survey. In the case of the eastern ports the lengths of record for the ports of reference—Quebec, Father Point, St. Paul Island, Halifax, and St. John—are longer than those of any Atlantic United States ports. These pamphlets are apparently distributed free of charge to mariners.

THE article by "G. H. B." in NATURE of January 20 on the proposals regarding "Decimal Coinage and the Metric System" which appeared in the *Electrical Review* has called forth a rejoinder in the issue of that journal for February 4. Our contributor writes with reference to the remarks in the *Electrical Review*:—This correspondence has had at least one good effect, namely, that it has forced the writer of the articles in that journal to state clearly and definitely which system of decimal coinage he proposes to adopt. He would do well to remember that the name "decimal coinage" is vague and meaningless, since every country which has a small monetary unit divided into still smaller cents calls that system a decimal one. In the article in NATURE the term was purposely discussed in its most general aspect, and if the writer in the *Electrical Review* considers this to be an indication of "confusion," he and other advocates of currency reform would do well to remember that they have only themselves to blame if endless confusion arises from their failure to adopt a more distinctive name for their system. We are now told that the proposal would not have any effect on international commercial transactions conducted on a large scale (the pound being unaltered), but that it would alter the copper coinage. The change in the latter would be far more confusing to the working classes and the poor than the mere doubling or halving which gave so much trouble in Austria, although it only involved renaming the kreuzer while still retaining the monetary value of that coin. The present reply fully confirms the main contention of our article, namely, that it would be a serious mistake to spoil our prospects of adopting international standards of

weights and measures by associating them with a proposal of so fundamentally different a character.

THE *Electrical Review* for February 4 contains an illustrated article on the laboratory for heating and ventilation, which has been opened at University College, London, under the charge of Mr. A. H. Barker. The equipment described consists mainly of apparatus for measuring temperatures, radiated and convected heat, the efficiencies of gas and electrical radiators, for testing hot-water pipes, for determining the slope of temperature through the walls to the outside, and for measuring the resistances of air ducts. Mr. Barker's laboratory appears to be the first one established by any university for the special study of the scientific problems of heating and ventilation, but some important pioneer work on the scientific treatment of ventilation was done by Sir Napier Shaw in the Cavendish laboratory at Cambridge twenty years ago. We welcome the inclusion of this work within the sphere of the University, and hope that ere long even those who now advocate the study of Greek verse as an unrivalled educational training will look on the scientific study of the problems underlying everyday life as worthy of some consideration.

INSTRUMENT-MAKERS will find some useful suggestions in a short paper by Mr. A. P. Trotter in the *Journal of the Institution of Electrical Engineers* for February 1. In 1908, Mr. Trotter prepared some

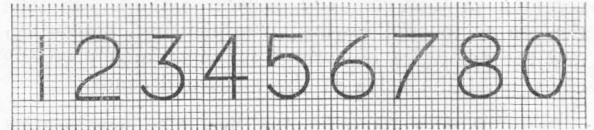

Numerals designed by Mr. A. P. Trotter, minimum thickness.

notes on the most suitable numerals for the scales of measuring instruments; these were recently placed at the disposal of the Meter Panel of the Engineering Standards Committee, and have now been published at their suggestion. Most of the figures which Mr. Trotter proposes as "standard" combine the maximum of legibility and convenience with a considerable degree of elegance; his 2, 3, and 7 are admirable. A more open 5, with the vertical and horizontal lines further to the right, may, however, be preferred; and this would enable the tails of the 6 and 9 (which it is proposed should simply be an inverted 6) to be set at a less violent and unconventional angle without danger of confusion between the 5 and 6; the extension of the horizontal bar of the 5 to the right, beyond the rest of the figure, would preserve its distinction from the 3. A slightly wider 4 would also be an improvement.

ONE of the principal effects of the war on chemical industry in this country has been to curtail largely the supplies of sulphuric acid available, and to produce an increased output of acid sodium sulphate or "nitre-cake." In many cases it would appear possible to utilise the nitre-cake as a substitute for sulphuric acid. The *Chemical Trade Journal* of January 29 contains an article dealing with the question. A special committee has been appointed in the West

Riding to devise regulations for the substitution of nitre-cake for sulphuric acid in various processes of the woollen trades, and to arrange for the best centres to which the Government Explosives Department can send quantities of nitre-cake for the convenience of local users. The greatest difficulty lies in carting and transport. It is pointed out that the shortage of acid seriously affected the wire trade of some districts, and that the Government, although taking action with regard to the textile trades, has apparently not yet realised how seriously the wire trade is affected by the shortage of acid.

THE final general memorandum on the indigo crop of 1915-16, based upon reports received from provinces containing practically the whole area under indigo in British India, has been issued by the Department of Statistics, India, and forms the subject of a short article in the *Chemical Trade Journal* of January 29. The total area (314,300 acres) is 112 per cent. in excess of the finally revised value of last year (148,400 acres). The total yield of dye is estimated at 39,900 cwt., as against 25,200 cwt., or an increase of 58 per cent. The average output per acre works out at 14 lb., as against 19 lb. in the preceding year. The increase in area is due to high prices of indigo due to the war, which range from 12s. to 13s. a lb., as compared with 2s. 8d. in 1913. The season on the whole has not been favourable to the crop, except in Madras. In some places poor crops were obtained owing to a scarcity of trustworthy seed at the sowing time. Data are given showing the quantities of natural and synthetic indigo imported into the United Kingdom in the last five years.

A PAPER on turbo blowers and compressors was read recently before the South Wales Institute of Engineers, and is reprinted in *Engineering* for February 11. The authors, Mr. H. L. Guy and Lieut. P. L. Jones, give very full details and methods of design for both classes of machines. There is also an appendix on the measurement of large quantities of air, and the authors state that the most convenient and accurate method consists in discharging it into the free atmosphere through a standard convergent nozzle. A drawing of this nozzle is given. Care must be taken that the air approaches the nozzle in a steady, uniform stream. It is only necessary to measure the temperature and pressure before and after the nozzle in order to be able to calculate the volume of air passing through it. The coefficient of discharge has been measured for the author's standard nozzle and has been found to be between 1.0 and 0.99.

MESSRS. DULAU AND CO., LTD., will publish almost immediately a translation of Thonner's "The Flowering Plants of Africa: an Analytical Key to the Genera of African Phanerogams." The work, which has been revised and brought up to date, will contain 150 plates.

THE Cambridge University Press has undertaken the publication in this country of two new American medical journals, viz., *The Journal of Cancer Research* and *The Journal of Immunology*. The first-named periodical (which will be issued quarterly) will be the official organ of the American Association for

Cancer Research, and contain contributions dealing with statistics, immunology, pathology, and inheritance. The second journal will be a bi-monthly, and represent the American Association of Immunologists and the New York Society of Serology and Hematology.

THE following monographs are in preparation for publication by the Ray Society:—The British Centipedes and Millepedes, by W. M. Webb; The British Earthworms, by the Rev. H. Friend; The British Hydrachnidæ, by C. D. Soar and W. Williamson; The British Ixodoidea, by W. F. Cooper and L. E. Robnson; and The Earwigs of the World, by Dr. M. Burr. The three following works are in course of publication:—The British Desmidiaceæ, by W. and Prof. G. S. West; The British Freshwater Rhizopoda and Heliozoa, by the late J. Cash and G. H. Wailes; and The British Marine Annelids, by Prof. W. C. McIntosh.

OUR ASTRONOMICAL COLUMN.

PERRINE'S COMET (1896 VII.).—This periodic comet is due to return to perihelion about the middle of April. Search ephemerides have been calculated by Dr. G. Stracke from orbital elements obtained from observations made during its 1909 apparition for three assumed dates of perihelion passage, namely, April 7.5, 15.5, and 23.5, and are given in Circular No. 500 of the *Astronomische Nachrichten*. The comet is apparently close to the sun on the opposite side from the earth, and at perihelion will be 200 million miles from the latter.

COMPARISON OF PENDULUMS.—The method of coincidences enables the rates of pendulums to be compared with considerable accuracy even without accessory apparatus. Using the "flash-box"—an optical device that enables the moment of coincidence to be determined with greater precision—estimations of one-thousandth of a second are usually made in gravity work. Seven significant figures are obtained in the deduced times of oscillation of "half-seconds" pendulums. An even higher order of accuracy is claimed for an electro-acoustical method tried by M. A. Perot (*Comptes rendus*, clxii., No. 5), that is stated to render sensible periods less than $1/250,000$ of a second. The arrangement employed consists of a battery and condenser shunted through very high resistance, connected in parallel to two open circuits, including telephones. Contacts made by the pendulums under comparison make the circuits, and equality of the sounds given by the two telephones indicates coincidence.

THE VARIATION OF LATITUDE.—Prof. Kiyofusa Sotome, who for a number of years had charge of the latitude observations at Tokyo, suggests an explanation of the Kimura "z," also embracing the lesser-known term given by the chain-method of reduction, namely, the "closing sum." Both together are held to be a measure of the "imperfection" of the spirit-level. In the course of evaluating the micrometer screw by high-latitude stars, it was found that whether the zenith telescope was in the east or west position the bubbles of the pair of attached levels showed a southerly creep about four times greater in winter than in summer. For this two causes are found to be about equally operative; one resides in the spirit-levels and is independent of a regular northward tilt of the telescope that accounts for the other half. The varying inclination of the telescope is due to differential changes in the stand and also to a periodic diurnal

tilting of the pier and ground. Both these effects are of thermal origin, meteorological conditions modified by the observer's presence being responsible for the former, the latter being due to solar heating. Even in the underground chambers where horizontal pendulum work is carried on, daily oscillations of level due to the sun have been manifested. Prof. Sotome next investigates the theory of the motion of the level bubble, the upshot being that the imperfection of the spirit-level is not negligible in zenith telescope observations. It is instructive to note that the errors under investigation are of the order of hundredths of a second of arc! It is finally concluded that both the "z" term and the "closing sum" would vanish if the spirit-level were a perfect instrument or if it were replaced by means more nearly ideal, such, for instance, as presented by the Cookson floating zenith telescope (Journ. Coll. of Sci., Tokyo, vol. xxxvii., art. 3).

DINOSAURS.

THE American Museum of Natural History, New York, has just issued Handbook No. 5, giving a popular and well-illustrated account of the Dinosaurs.

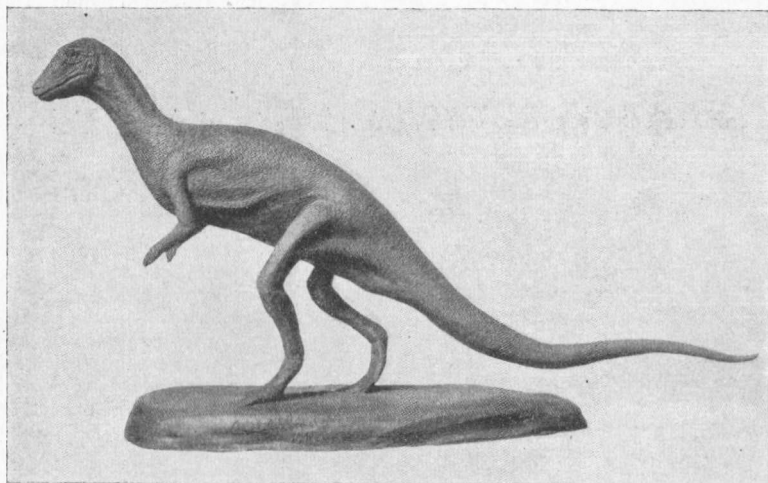

Restoration of an Iguanodont Dinosaur, *Thescelosaurus neglectus*, from the Upper Cretaceous of Wyoming, U.S.A., by Dr. C. W. Gilmore. Height 4 ft., length 10 ft.

It has been prepared by Dr. W. D. Matthew, and is in large part a reprint of papers already published by himself, Prof. H. F. Osborn, and Mr. Barnum Brown. Prof. S. W. Williston has also contributed an interesting historical chapter on the first discovery of Dinosaurs in western North America, in which he himself took a prominent part. There is naturally some repetition in the reprints, with occasionally divergent opinions; but the handbook affords an admirable glimpse of the various groups of these strange Mesozoic land-reptiles, besides an ample discussion of the theories as to their modes of life. Several of the beautiful illustrations are only accessible elsewhere in technical memoirs, and Dr. Matthew has added some new synoptical diagrams which will be useful to students.

A small bipedal Dinosaur related to the familiar Iguanodon, and almost identical with the English Wealden *Hypsilophodon*, has been discovered in the Upper Cretaceous Lance Formation of Wyoming, U.S.A. The greater part of a skeleton, lacking only the skull and neck, has lately been uncovered in a

slab of rock in the United States National Museum, and is described by Dr. C. W. Gilmore in No. 2127 of the Proceedings of that museum. The bones lie almost in their natural position, and Dr. Gilmore has wisely decided to leave them undisturbed in the matrix. There are also slight traces of the skin, with fine epidermal tubercles, but no dermal ossifications. The reptile is named *Thescelosaurus neglectus*, and when restored with the head and neck of *Hypsilophodon foxi*, appears as represented in the figure which we copy from Dr. Gilmore's paper. In this attitude it would measure about 4 ft. in height, and it is obviously of very agile proportions, adapted for rapid running.

VENTILATION OF SOILS.

THE relation of soil gases to crop production has received considerable attention during the past year, notably in India. In Bulletin No. 52, issued by the Agricultural Research Institute, Pusa, Mr. and Mrs. Howard discuss the ventilation of soils in the great alluvial plains forming the Ganges basin and in the Quetta valley of north-west India. The authors think that, in a country like India, where water is so often the limiting factor in crop production, too little attention has been paid to the importance of continuous gaseous interchange between the soil and the atmosphere during the growing period. The conclusions reached in this paper are not based on direct experiment, but on long-continued and almost daily observations on the growth of crops. Anticipating criticism on the lack of what they term "test-tube evidence," the authors point out that the greatest advances in British agriculture, both as regards crop production and the improvement of stock, have been made by similar methods.

Having reviewed in detail the agricultural factors of the Bihar district, the phenomena of growth of the more important field crops and trees are briefly described. A large number of examples are given to illustrate the advantage derived by various plants from a free air supply to their root systems. The chief object of the cultivator of these alluvial soils should be to increase porosity and, in the absence of farmyard manure, green manuring or the use of broken brick or tile is recommended. The latter method requires less cultivation.

Similar observations are recorded in the Quetta valley, where both climate and soil differ considerably from those of the Bihar district. Under conditions of artificial irrigation the flooding of the land tends to pack the soil and cut off the supply of oxygen to the plant roots. It is claimed that the principle of more air and less water will not only yield a greater crop, but result in a valuable saving of irrigation water. The paper concludes with a reference to the ecological aspect of soil aeration as shown by the distribution of the gram-growing areas of India. This plant requires a great deal of air, and only a moderate amount of water. Wherever it is successfully grown the soil and system of cultivation are favourable to root aeration. The authors are to be congratulated on their systematic collection of data, which show clearly the importance of controlling the relation between air and water in the soil.

LACE-WING FLIES.

THE latest number of the *Arxius de l'Institut de Ciències*, published at Barcelona, contains an excellent monograph of the Chrysopidæ of Europe from the pen of Father R. P. L. Navàs, the well-known authority on the order Neuroptera. The present group, sometimes known as Hemerobiidæ, and in this country as "lace-wing flies," or "golden-eyes," presents many features of interest. From the point of view of economic entomology its importance rests on the fact that in the larval stage it is a great destroyer of aphids. Unlike the almost stationary larvæ of the Syrphids, or hawkflies, which are also of much value as devourers of plant-lice, the Chrysopid larva is able to move actively about from place to place in search of its prey. In this it resembles the larva of the ladybird, another great ally of the agriculturist against the same enemy.

The Chrysopid in its perfect state is a beautiful object; the fresh green colour of its body, which is also prolonged into the delicate tracery of its wings, and the large lateral compound eye-masses, which shine during life like burnished gold, give it an attractive appearance. This, however, is scarcely borne out by its behaviour, for it is capable when crushed or otherwise injured of emitting a most disgusting odour. The latter property may perhaps serve in some degree as a protection to the insect, a suggestion that seems to be favoured by its feeble and fluttering mode of flight. The ova are curious structures, being fastened in groups to the surface of a leaf by means of slender footstalks, thus, as Fr. Navàs points out, resembling a growth of minute fungi.

The present treatise, which is well illustrated, gives a full description of all the European Chrysopids, with a complete bibliography and a key for the diagnosis of the various species.

THE POSITION OF SCIENCE.

MEMORIAL FROM THE IMPERIAL COLLEGE.

THE following memorial, presented by the Right Hon. Arthur H. D. Acland, chairman of the Executive Committee, and Sir Alfred Keogh, rector (now acting as Director-General of the Army Medical Service) of the Imperial College, and by Sir John Wolfe-Barry, chairman of the delegacy of the City and Guilds (Engineering) College, has been forwarded to Lord Crewe, chairman of the governors of the college:—

"To the Marquess of Crewe, K.G., Lord President of the Council, Chairman of the Governors of the Imperial College.

"We, the undersigned, desire to support the Memorandum on the neglect of science in this country which was signed by thirty-six eminent men of science (including four former professors of this College), and published on February 2 last; and as the Imperial College is directed by its charter to concentrate itself on 'Science in its application to Industry and to give the highest specialised instruction and provide the fullest equipment for the most advanced training and research' in various branches of science, we think it right to call your Lordship's attention to the extreme importance of this question at the present crisis in our national history.

"In the Memorandum it is truly said that 'This grave defect in our national organisation is no new thing. . . .' In the year 1887 Prof. Huxley, who was for fifteen years Professor and Dean of the Royal College of Science and Royal School of Mines, which are now with the City and Guilds (Engineering) Col-

lege integral parts of the Imperial College, said:—'Everybody . . . here is aware that at this present moment there is hardly a branch of trade or of commerce which does not depend, more or less directly, upon some department or other of physical science, which does not involve, for its successful pursuit, reasoning from scientific data.' This statement remains as true now as when it was made.

"We do not wish to take up your time by asking you to see us personally, but we consider it to be our duty to let you know as our Chairman that we cordially support the views of the signatories to the Memorandum, and sincerely hope that in a matter so vital to the welfare of the country remedial measures may be adopted."

The memorial is signed by the following professors, chairs being given in brackets:—H. B. Baker (Chemistry); V. H. Blackman (Plant Physiology); W. A. Bone (Chemical Technology—Fuel and Refractory Materials); H. L. Callendar (Physics); H. C. H. Carpenter (Metallurgy); C. Gilbert Cullis (Economic Mineralogy); W. E. Dalby (Mechanical and Motive Power Engineering); Stephen M. Dixon (Civil Engineering); J. Bretland Farmer (Botany); A. R. Forsyth (Mathematics); A. Fowler (Astrophysics); Wm. Frecheville (Mining); Percy Groom (Technology of Woods and Fibres); E. W. MacBride (Zoology); T. Mather (Electrical Engineering); J. C. Philip (Physical Chemistry); H. G. Plimmer (Comparative Pathology); R. J. Strutt (Physics); Jocelyn Thorpe (Organic Chemistry); A. N. Whitehead (Applied Mathematics); W. Watson (Physics); and W. W. Watts (Geology).

SCIENCE AND GOVERNMENT.

PROF. E. B. POULTON, in delivering the third Galton lecture before the Eugenics Education Society on February 16, said that the justification of the society lies in the fact that man, acting in a community, cannot help letting loose the forces that "improve or impair the racial qualities of future generations either physically or mentally." When these forces are tremendous, as in war, immense future effects must follow. The victory of Germany would impose upon mankind a new criterion, leading to the predominance of a revolting type. But every law, custom, or tradition by which society helps or restrains any of its individual members has some effect for the good or for the evil of future generations. Society is influenced by the tradition that marriage between first cousins is injurious. In consequence of this tradition such marriages are less frequent than they would otherwise be. There is no evidence that the tradition is well founded, and, in July, 1870, Charles Darwin wrote to Sir John Lubbock, pointing out that it was "manifestly desirable that the belief should either be proved false, or should be confirmed," and suggesting that the proper queries should be inserted in the forthcoming census. When the Bill was considered in committee, Lubbock moved to insert the words, "whether married to a first cousin," but the motion was opposed for all sorts of frivolous reasons, and finally rejected by 92 votes to 45. The neglect of eugenics by the Government has been as conspicuous as its neglect of other branches of science. The next general election will reveal a revolution in the political thought of the country, and the urgent necessity for the society will be to fight alongside the other sciences and the great business interests of the country, ensuring that scientific men and business men shall have weight in our future form of Government. When the war came the late Prof. Meldola, with his unrivalled knowledge of the relations between science

and industry, was asked by the authorities to preside over some committees and to serve on others in order to help the Government, and the country, out of the dilemma. He was too patriotic to refuse, but the strain was too great for one who was far from strong, and he died after a few months of overwork. How can the country be saved from the disastrous consequences of the neglect of science? How can the society hope to improve, by means of an enlightened Government, the racial qualities of future generations? The remedy is simple, but there is every reason to believe that it will be effective. All that is necessary is to change the character of the examination for the Civil Service posts and for the Army, giving science a far more important place than it has held hitherto. This change would at once react on our public schools and the old universities, and would bring the members of future Parliaments under the influence of science.

✓ POLARISED LIGHT AND ITS APPLICATIONS TO ENGINEERING,¹ *abridged.*

ONE of the fundamental questions which arises in the majority of engineering problems is the design of a structure or machine which will carry out some predetermined work in an efficient and economical manner, and whatever the problem may be, it is almost invariably bound up with the arrangement of a number of connected parts designed to resist loads which are imposed upon them.

The machines and structures which the engineer has to construct are almost infinite in their variety, and each one usually presents a new and a difficult problem, especially as regards the stresses which may be imposed upon its parts, and the way in which these stresses are distributed.

It is a common experience among engineers to find themselves confronted with a stress problem in their designs which presents almost insoluble difficulties; it often defies mathematical processes, and is beyond the scope of any previous physical investigation. But it must be solved, if only approximately, and the imperative need of an answer renders it advisable to make experimental investigations before proceeding with an important work of construction.

It is perhaps somewhat severe, but not untrue, to say that engineers have not always made the fullest use of the discoveries of pure science in their practice; and it is remarkable that a discovery of Sir David Brewster, in 1816, that transparent materials when stressed become doubly refractive, should not have been more frequently pressed into service, for its use was immediately obvious to the discoverer, who pointed out that the stresses in the arched rings of bridges could be rendered visible in a glass model by aid of the doubly refractive effect produced by a beam of polarised light.

Here and there one finds accounts of applications of this property for engineering work, but usually with little success, mainly owing, no doubt, to the difficulties experienced in shaping glass models to the required form; but when these are overcome the value of the information gained is very great, as, for instance, in the recent valuable investigations of the stresses made upon a glass model of a reinforced concrete arch by M. Mesnager, of Paris, who used the results so obtained for the design of an arch of about 310 ft. span, with a most gratifying agreement between the stresses in the actual bridge and its model. The expense and difficulty of constructing glass models are a bar to their general use, and other transparent materials are now available which offer

many advantages, in that they are strongly doubly refracting under stress, are easily fashioned with engineering tools, and are not readily broken or damaged, while the cost is insignificant.

Here, for example, is a rough model of an arching, made of xylonite, and you observe that when loads are applied, it glows with colour in the polariscope, and a picture of the state of internal stress is obtained which can be readily interpreted.

Measurement by Colour Effect.

We can estimate simple stresses by the colours observed.

If, for example, we take a strip of transparent material, and arrange the optical apparatus so that when the strip is unloaded no light is transmitted, the effect of a moderate tension causes the specimen to appear a greyish-white, and, as the stress increases, the colour changes by insensible gradations to a lemon-yellow, then to a reddish-purple, and, with a very little increase of stress, to a well-defined blue. With a further increase of stress, the scale of colours is approximately repeated for twice the intensity of stress, and the relation of colour to stress can be easily determined.

For simple tension and compression, therefore, the stress intensity may be inferred by observing the colour bands, bearing in mind that both tension and compression produce similar effects, if changes in the thickness of the material are allowed for. Thus, if we take the case of a transparent beam subjected to a uniform bending moment, a system of colour bands is obtained, distributed as shown in the accompanying experiment, and, by inspection, the distribution across the section can be determined as shown in the diagram.

This case and others which have been examined afford instances where the results of optical experiments can be compared, not only with mechanical measurements of strain, but also with the theory of the distribution of stress in materials; and the experimental determinations for a transparent material show a very good agreement with strain measurements and with the precise theory. We can, therefore, feel very confident that in more complicated cases the stresses in a transparent model are similar to those in a metal. For example, a beam with a notch cut in it may be taken (as shown), and, as might be expected, the effect of the notch is seen to increase the stress in the material very considerably. The distribution is now much more complicated than it is in a simple beam; the neutral axis has moved towards the notch, while the colour effects show that the maximum stress is at least twice as great as that in a beam without a notch.

Laws of Optical Effect.

In most of the cases arising in engineering work the stress distribution is even more complex, but it is known that any case of stress in the plane of a plate can always be represented by two principal stresses at right angles, and if the magnitude and direction of these are determined for all points the stress distribution is solved.

In order to obtain an experimental solution of this problem, it is necessary to inquire into the relation of the optical effect to the principal stress intensities at a point, and it is easy to show this by simple experiments. If, for example, we take two tension members and subject them to the same uniform stress intensity, the colour effects produced by interference will be precisely the same for each, while if they are superposed the colour effect is that produced on a single member under twice the stress. If, however, two equally stressed tension members of the same thickness are crossed, the common area gives a

¹ Abridged from a discourse delivered at the Royal Institution on Friday, February 18, by Prof. E. G. Coker.

dark field, showing that the stress effect of one neutralises that of the other. The same dark field is produced if an equally stressed compression member is placed with the direction of stress parallel to that of the tension member, and we may readily verify in all cases that tension and compression stresses in the same direction add their effects, while stresses in directions, at right angles subtract them.

The latter result is of chief importance, since the stress at any point of a plate can always be represented by the stresses p and q at right angles, and their optical effect is therefore proportional, $p - q$. The value of the stress difference may therefore be determined by matching the optical effect produced at the given point with that produced on a simple tension or compression member. The eye is, however, not a very trustworthy instrument, especially after the fatigue of a few minutes' exposure to a brilliant light; and it is better still to reduce the optical effect to zero by a simple tension or compression member set along one of the directions of principal stress, and stressed until a dark field is produced.

The laws which the optical effects obey may be at once utilised for a variety of cases of practical interest.

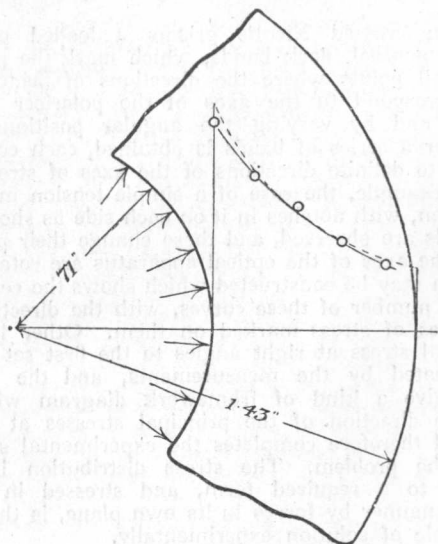

FIG. 1.

Thick Cylinder.

An example is furnished by piping for transmitting fluids under pressure. The action of water, or other fluid, in a pipe, can be imitated by applying a uniformly distributed pressure to the interior of a ring, such as is now shown, where the application of a uniformly applied pressure produces a stress distribution in the circular ring of a perfectly symmetrical character. The arrangement of the colour bands shows that there is a very large stress at the interior surface, diminishing rapidly at first, and afterwards more gradually as the outer surface of the pipe is approached. In this case there is known to be a radial compression stress accompanied by a circumferential tension stress, and the optical effects produced at any point are proportional to the algebraic difference of their intensities—in this case their numerical sum.

In a thick cylinder of these proportions the radial stress is not large, and its intensity can be determined independently, but the combined effects of both stresses have been measured here, and are plotted in Fig. 1, in which the firm line gives the experimental values

obtained, while the dotted curve represents the results of calculation.

In an experiment carried out on a ring in which the inner radius, $r_1 = 0.71$ in., and the outer radius, $r_2 = 1.43$ in., a pressure of 900 lb. per sq. in. was applied to the interior of the ring, and the experimental values compared with those obtained by calculation. The following results were obtained:—

TABLE I.

Radius r inches	Experimental value		Calculated value
	Observed	Corrected for cup leather	
0.71 ...	2100 ...	2185 ...	2400
0.85 ...	1560 ...	1625 ...	1660
1.00 ...	1185 ...	1230 ...	1205
1.15 ...	870 ...	905 ...	910
1.30 ...	670 ...	700 ...	715
1.43 ...	— ...	— ...	588

The results show a fair agreement with the theory, which is really closer than the numbers indicate, owing

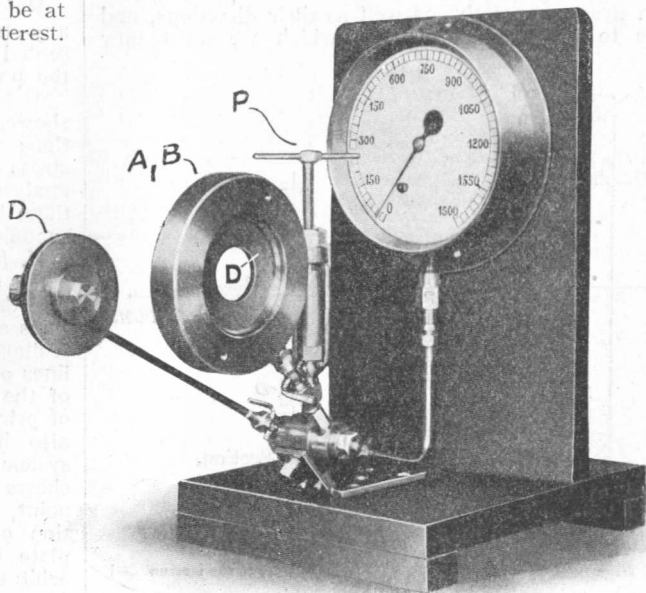

FIG. 2.

to the full pressure recorded on the gauge not being effective, as will now be described.

As is evident, this stress problem requires the application of a measurable fluid pressure to the cylindrical surface of a ring, in such a way that no essential part is obscured from view, and a simple and effective means has been devised for this purpose by my assistant, Mr. F. H. Withycombe.

Fig. 2 is a photograph of the complete apparatus for applying internal and external fluid pressure to rings, and drawings of the essential details are shown in cross section in Fig. 3.

Fluid pressure of water or other liquid is applied by the action of a small hand-pump P, the piston of which is actuated by a screw to force oil at any desired gauge-pressure into the annular space between two metal discs A, B, bolted together to hold a retaining ring C, shaped like a Bramah cup-leather to prevent leakage of the fluid. This retaining ring projects slightly beyond the periphery of the discs, and carries the transparent ring to be stressed. The cup-leather is itself so thin that a pressure of a few pounds per

square inch will burst it, but when the ring D is mounted upon it, even a pressure of 2000 lb. per sq. in. may be applied with safety. In the experiments described above, the ring had a thickness equal to the interior breadth of the cup-leather, but a small percentage of the total pressure is absorbed by this leather, and is not exerted upon the ring. The experimental results must therefore be slightly lower than the calculated values, and, if the correction is made, there is a very good agreement, as the table shows. In more complicated cases the stresses are less amenable to calculation, as in cylinders provided with ribs for aeroplane engines, or tubes constructed in sectors bolted together, as in underground railways, but it would not be difficult to determine experimentally the stresses produced under working conditions, although not in so simple a manner.

So far our measurements have only utilised a property which enables us to measure the difference of the principal stresses at a point in a plate subjected to plane stress, but by far the greater number of problems require a knowledge of the magnitudes of each stress separately, as well as their directions, and it is to these determinations which we must now

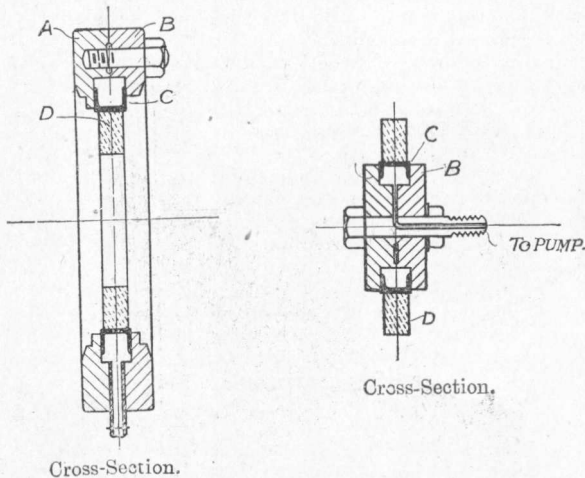

FIG. 3. Pressure chambers for applying fluid pressure to the internal and external boundaries of rings.

address ourselves. First, as to the determination of the magnitude of the principal stresses:—

Principal Stresses.

A measure of the sum of the principal stresses at a point can be obtained, as Mesnager suggested, if advantage be taken of the fact that the stress causes a change in the thickness of a plate of material proportional to the sum $(p+q)$ of the principal stresses in its own plane. If, for example, both stresses are tensions, there will be a lateral contraction of $(p+q)/mE$, where E is the modulus of direct elasticity, and m is Poisson's ratio. Both these latter quantities can be determined, and the sum of the stresses can be measured, if an extensometer is used of sufficient accuracy to measure the lateral contraction. For each 1000 lb. of stress intensity, the corresponding lateral contraction for plates of the usual thickness of $\frac{1}{4}$ in. is $1/3000$ of an inch, and to measure such a quantity to an accuracy of within 1 or 2 per cent., it is advisable to use an instrument capable of indicating a change of at least one-hundredth of this quantity; such changes have been measured with fair accuracy by using a lateral extensometer capable of detecting a change of about half a millionth of an inch. An in-

strument of this kind has been employed by Mr. Scoble and myself for an investigation of the stress produced by a rivet in a plate, and a photograph of one form of this apparatus is now shown on the screen.

For investigating cases of plane stress in general the combination of the optical and mechanical methods described here is chosen, in which the sum of the two principal stresses at a point is found by a lateral extensometer, and the difference by an optical measurement, since both can be made to depend upon mechanical measurements only, and are therefore particularly adapted for engineering work. In some cases it requires considerable care to obtain accurate values of each quantity separately, especially if one stress is very much smaller than the other, as then minute errors of observation become a large percentage of the value of the lesser stress; but possibly this difficulty would be met with in any other method.

Lines of Principal Stress.

Reference has already been made to the fact that any state of stress at a point in a plane may be represented by a pair of stresses at right angles through the point.

Between crossed Nicol's prisms a loaded plate shows, in general, dark bands, which mark the positions of all points where the directions of principal stress correspond to the axes of the polariser and analyser, and by varying the angular positions of these latter a series of bands is obtained, each corresponding to definite directions of the axes of stress.

If, for example, the case of a simple tension member is taken, with notches in it on each side as shown, dark bands are observed, and these change their positions as the axes of the optical apparatus are rotated. A diagram may be constructed which shows the centre lines of a number of these curves, with the directions of the axes of stress marked on them. Other lines of principal stress at right angles to the first set are also indicated by the measurements, and the two systems give a kind of framework diagram which shows the direction of the principal stresses at any point, and therefore completes the experimental solution of the problem. The stress distribution in a plate cut to a required form, and stressed in an arbitrary manner by forces in its own plane, is therefore capable of solution experimentally.

Complete Solution.

The complete experimental solution of the stress distribution in a plate stressed by forces in its own plane, may be illustrated by an investigation mentioned above of the action of a rivet near the edge of a riveted joint, since we can determine the sum $(p+q)$ of the principal stresses, their difference $(p-q)$, and their directions. In this problem we can no longer neglect either principal stress, and it is in general necessary to determine both their directions and magnitudes. If the uniform tension stress in the full section of a plate is represented by equally-spaced lines in the direction of stress, we may expect to find alterations in their directions and distances apart as they draw near to the discontinuity produced by the rivet, and an optical examination shows that the lines of stress approach one another very closely as they pass around the rivet, and afterwards diverge again if the overlap of the plate is sufficient to permit this. It is not difficult to explore the whole of a plate stressed in this way, by determining both the sum and difference of the stresses at a sufficient number of points on the lines of stress so found, and some of the measurements for the cross

section passing through the centre of a rivet in a plate are shown in Table II., for the case of a plate in which both the overlap and the widths of metal on each side of the rivet are equal to the diameter of the rivet.

TABLE II.

Stress ratios	Stresses across the section						
	r/a	r/a	r/a	r/a	r/a	r/a	r/a
r/a ...	1.20	1.40	1.60	1.80	2.00	2.50	3.00
$(p_t + p_r)/p$	2.55	2.20	1.84	1.47	1.18	0.70	0.22
$(p_t - p_r)/p$	2.80	1.60	1.00	0.76	0.56	0.10	-0.17
p_t/p ...	2.68	1.90	1.42	1.11	0.87	0.40	0.025
p_r/p ...	-0.125	0.30	0.42	0.35	0.31	0.30	0.195
Stresses on centre line below rivet							
r/a ...	1.40	1.50	1.70	1.90	2.20	2.50	2.80
$(p_t + p_r)/p$	-4.31	-2.32	-0.90	-0.37	0.43	1.27	2.05
$(p_t - p_r)/p$	-2.56	-2.32	-1.87	-1.48	-1.25	-1.32	-1.60
p_t/p ...	-3.44	-2.32	-1.39	-0.93	-0.41	-0.025	0.225
p_r/p ...	-0.88	—	0.49	0.55	0.84	1.20	1.82

In these determinations the distance r of the point examined is measured from the centre of the rivet

Blocks in Compression.

A problem of considerable importance in practical engineering is the distribution of stress in a rectangular block subjected to pure compression. This case occurs in the testing of materials when equal and oppositely directed loads are applied to the parallel faces of a short rectangular block, of a material like stone, brick, or concrete, to give a compressive stress as uniformly applied as is possible.

The manner in which the load is applied to the end faces of such a rectangular block is known to exert an influence upon the distribution of stress and strain, and to obtain consistent results the end faces of small specimens are sometimes faced by aid of a surface plate in order to give a uniform bearing. In a large specimen, where this process becomes very laborious, it is often faced with plaster of Paris, and plates of millboard are sometimes interposed in addition, to give a uniform bearing area between the pressure plates of a testing machine and the specimen.

It is difficult to determine experimentally the distribution of stress in a short block of an engineering material, but if a transparent model is used the problem is comparatively simple; and it may therefore be of interest to indicate what progress has been made in the solution of this practical problem by Prof. Filon and myself.

In the majority of testing machines the mechanical arrangements for applying a pure compression load are defective, and for investigations of this kind a special form of testing-machine was constructed to give a very accurately applied load; and, in order to facilitate the measurements, it was found convenient to suspend the lateral extensometer, X, from a three-point support (Fig. 5), borne by a block sliding upon the vertical pillars P_1, P_2 of the testing machine, and having two cross horizontal slides B and C at right angles, these latter being capable of adjustment by micrometer screws D and E, in such a manner that the measuring instrument can be moved to any position with respect to the specimen B, and the horizontal and vertical coordinates determined to an accuracy of 1/1000 in.

In the photograph now shown a block of square section is subjected to compression stress, and the optical effects show that the stress is far from uniform, although all possible precautions were taken to ensure a perfectly uniform bearing. It appears to be of much less intensity at the end faces than at the centre of the block. The measurements confirm this, and show that there is a very considerable end effect, tending to reduce the compression stress at the centres of the end faces, and only disappearing at a moderate distance away. In work of this kind where it is necessary to examine the effect of the pressure of an opaque body upon a transparent one, there is considerable difficulty in accurately measuring the stresses very close to the boundary between the surfaces.

The diagram now shown of some preliminary measurements indicates the general character of the distribution, in which the curves denote the vertical compression stresses at various distances from the end faces.

The non-uniform character of the stress distribution is evidently due to the way in which the pressure is applied to the material under test, and in this example the brass pressure plates prevent free lateral displacement of the material under load. If, therefore, a more extensible material is interposed for transmitting the load to the block, we may expect to obtain greatest stress at the centre, and this is actually what occurs.

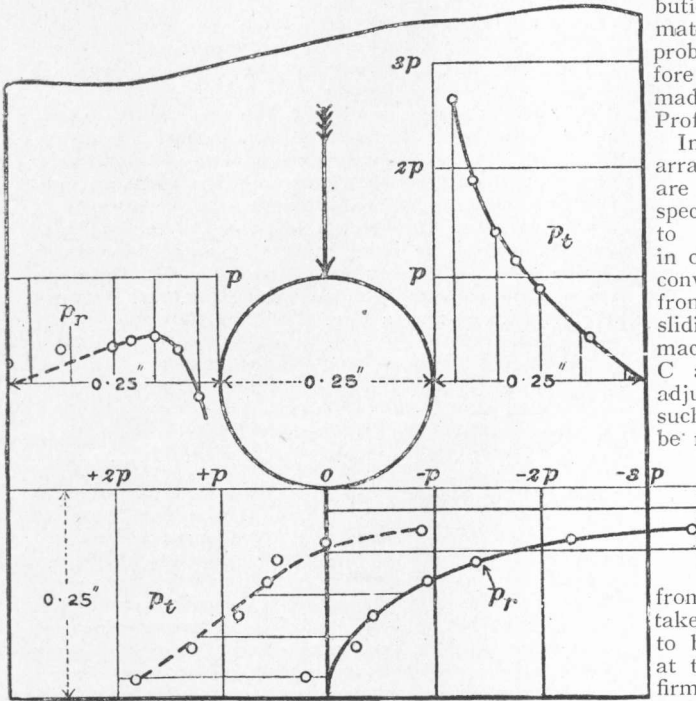

FIG. 4.—Load applied by rivet. Principal stresses.

in terms of its radius a , while the stress p_r across the section and the stress p_t in the section are given in terms of the mean stress.

The experimental values of the principal stresses are given in Fig. 4. They show that the tensile stress at the cross section reaches a high value, while below the rivet an even greater compression stress is produced. The measurements of radial stress along the sections chosen give marked compression close to the rivet, and it is worthy of note that they are very nearly zero at the outer boundaries of the plate, results which confirm the general accuracy of the measurements. Other measurements of a similar kind show that the action of a rivet produces an intense stress at the hole, sometimes reaching five times the stress in a full plate. In a transparent model this is often accompanied by permanent over-stress and local yielding, which latter tends to equalise the stress in the material.

A convenient material to interpose is a thin sheet of india-rubber, and a photograph of the colour effects clearly shows the widely different character of the stress distribution. The stress at the centre line is now the greatest, and it is, moreover, artificially increased 20 per cent. or thereabouts, for the same total load owing to the action of the interposed film of india-rubber, as the measurements

To ensure uniform stress conditions, the experimental results appear to point to the conclusion that the load ought to be applied through an intermediate layer of the same material, and when this is carried out, the block shows a very nearly uniform optical effect, and the measurements prove that the stress intensity is nearly uniform throughout.

Eye-Bars.

A promising development of experimental work with polarised light, relates to the design of machines and structures, especially the detailed parts or components. It has already been pointed out that in the majority of cases the stresses in even the simplest members are so complicated as to defy exact calculation, and with the simplifying assumptions usually adopted, it is necessary to allow for faulty methods by using a large factor of safety.

We may take a very simple example in the case of a member which is merely required to transmit a pull in the direction of its length by means of pins, as shown in the diagram.

If we take a member of rectangular form bored out at each end to receive the pins, then it is at once apparent that the material around the pin is very highly stressed compared with the body of the member, and, as we have already seen in the case of the rivet, there is a compression stress of very large intensity in one region, and a tension stress of considerable magnitude in another, but in the main body of the member, the section is excessive for the load applied. We have here, in fact, the problem which confronted the Deacon in Oliver Wendell Holmes's story of the wonderful "One Hoss Shay," which "ran a hundred years to a day."

"Fur," said the Deacon, "'t's mighty plain
That the weakest place mus' stan' the strain;
'n' the way 't' fix it, uz I maintain,
Is only jest
To make that place uz strong uz the rest."

In practice, therefore, the superfluous material of the main body is cut away, and a link is obtained with swelled ends, shaped to resist in the best possible way the stresses which come upon them. The form which these ends shall take to ensure the maximum possible strength is a problem which has exercised the minds of many engineers, particularly those engaged in the construction of large span-bridges of the pin-connected type, where such members occur in considerable numbers and of great size.

Some of the forms of ends which have been very generally used are shown on the diagram, and their diversity indicates the uncertainty which is felt as to the best possible shape; nor is it easy to devise a method of selection unless the stresses in these forms can be measured.

An optical investigation of a model does this effectively and quickly. A very common form is that in which the swelled end has a contour bounded by a circle concentric with the pin, and if we use proportions very widely adopted, it is easy to see from the colour effects on the loaded model now shown, that the stress distribution is unsatisfactory; in fact, at the principal transverse section (Fig. 6) the normal stress is that of compression at the extreme edge, and undue stress is therefore thrown upon the remainder of the section, to balance the total pull on the member. This is also indicated by the lines of stress which have been plotted from the observations.

A much better shape is one devised by Berkeley, and the reason for its special excellence is, I think, clear from the picture of its stressed condition which is before you, from which you will see that the head

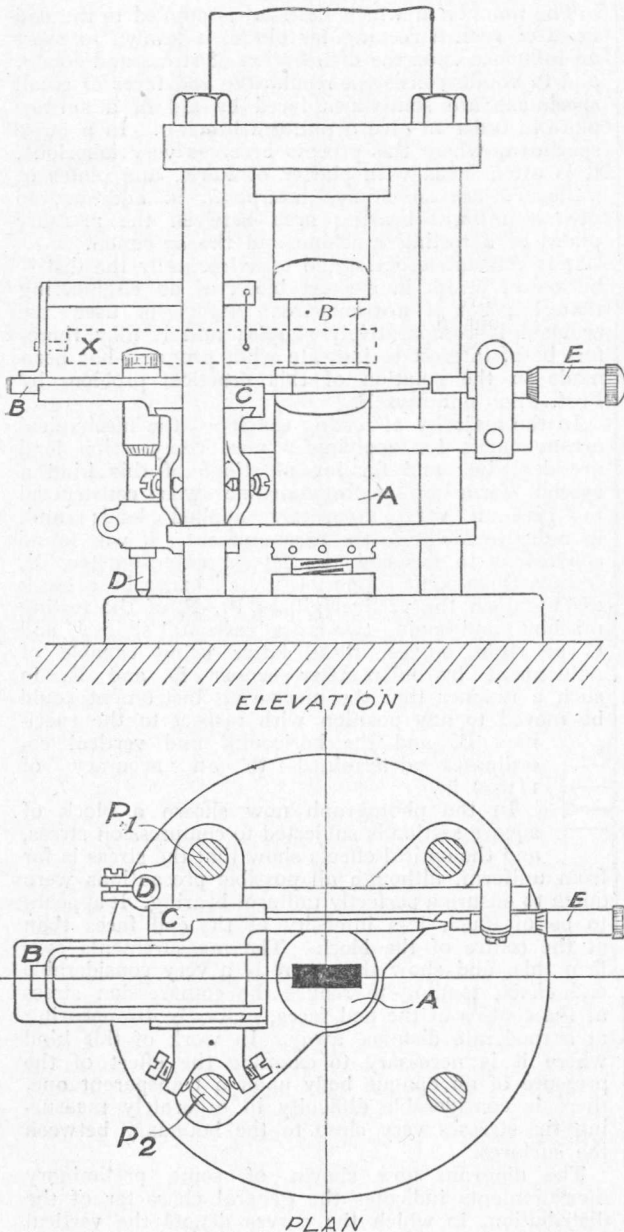

FIG. 5.

show. It is, moreover, not a local effect confined to a small area at the ends, but exerts an effect over the greater part of the block.

The injurious effect of a lead plate, when applied to give a bearing over a block of material under test, is confirmed by this experiment, and the measurements give a quantitative estimate of the increase in stress intensity.

is so proportioned that the principal transverse section is wholly in tension (Fig. 7) and is much more evenly distributed than before, while the elongated head allows a more even distribution in the longitudinal section. The contour is apparently not entirely satisfactory, as the head merges into the main body in a somewhat abrupt manner, and suggests that a more satisfactory solution would be obtained by more gradual transition curves following one of the system of curves of principal stress in a member of rectangular form, and of considerable width. If this is carried out as shown in the next model, you will, I think, observe that the effect of this change is a beneficial one, and the lines of stress are less curved, while there are no portions of the head which may be looked upon as of doubtful utility.

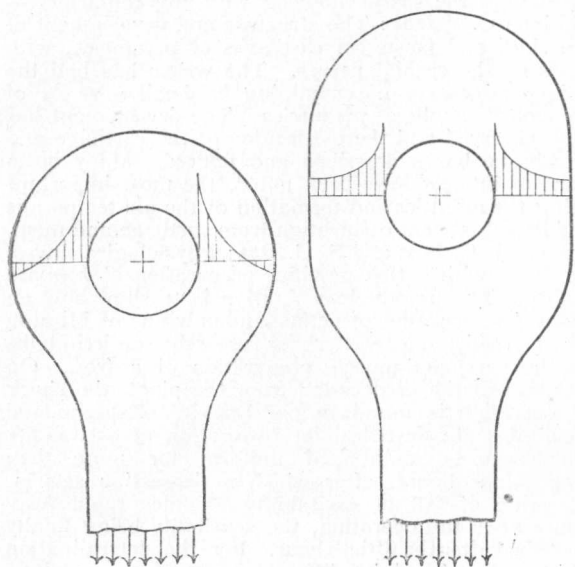

FIG. 6.

FIG. 7.

Economy in the use and distribution of material to resist stresses in a structure is clearly a most desirable end, and in perhaps no case is this more necessary than in some of the latest developments of modern engineering—the airship and the aeroplane—where weight is a most important factor; and tentative experiments upon models of links used in these structures show that some help in the solution of these new problems may possibly be afforded by optical investigations.

It would not be difficult to supply other examples, but the cases already described are possibly sufficient to show the use of polarised light in engineering problems of stress and strain, and to indicate the possible utility of stress pictures in other fields of applied science and industrial research.

UNIVERSITY AND EDUCATIONAL INTELLIGENCE.

OXFORD.—Mr. G. W. Walker, F.R.S., formerly fellow of Trinity College, Cambridge, has been appointed Halley lecturer for 1916, in place of Prince Boris Galitzin, resigned.

The report of the Committee for Rural Economy, which has just been issued, records the fact that the whole of the staff of the school who are of military age have accepted commissions, or are otherwise engaged on work connected with the war. The Sib-

thorpean professor (Prof. Somerville) has also accepted Government work. In spite of depleted numbers, research has been conducted on representative soils from the Belgian Congo, on soils in the Oxford district, on the reaction of soil constituents towards solutions of phosphate, the comparative value of high and low basic slag, the relation between hygroscopic value and the results of mechanical analysis of soils, the effects of grass, etc., on the growth of trees, the storage of fertility in grassland as the result of the use of phosphates, and the life-history of *Stigmonota coniferana*, a microlepidopteron. The Institute for Research in Agricultural Economics, the aim of which is the application of scientific discovery to the practical business of food-production, has continued its work under considerable difficulty, mainly arising from the war. The chief subject investigated has been the cost of production in agriculture, particularly in regard to the expenditure upon labour. An agricultural survey of Oxfordshire has also been carried out, but many promising inquiries have had to be suspended.

The Board of Finance, presided over by Sir George Murray, has reported that, largely in consequence of the generosity of individuals, of the colleges, and of delegacies, the immediate difficulties of the year 1915 have been surmounted. The Board concurs in the proposal to establish an "Emergency Relief Fund," and thinks that later on in the year it will become necessary to reconsider the financial situation.

Leave of absence on account of war service has been granted to the professor of engineering science (Prof. C. F. Jenkin), and the Waynflete professor of mineralogy (Prof. H. L. Bowman).

MISS SARAH HOLBORN, who died on January 3, has left the sum of 1000*l.* to the London School of Medicine for Women.

THE conversazione of the Battersea Polytechnic will be held on Saturday next, February 26. The laboratories, workshops, and the polytechnic generally will be on view, and the evening affords an opportunity for the public to see the kind of work which is carried on in the training of men and women to fit them for the higher technical posts in industrial life.

ANNOUNCEMENT of a gift of 50,000*l.* for a library for Amherst College was made at the annual banquet of the Amherst Alumni Association of New York. The library is, *Science* states, to be a memorial to a graduate of the class of 1867 from a brother whose name is withheld. A gift of 30,000*l.* from a graduate of Wellesley College toward the fund for a new administration building is also announced by our contemporary. The donor does not wish her name made known at present.

ACCORDING to a correspondent of the *Times*, some education authorities are contemplating the re-introduction of slates to the schoolroom. Such a step would be a retrograde one, for it is generally recognised by hygienists that the slate and slate pencil—cleaned with saliva and sucked by the pupil—possess considerable capacity for the spread of infectious disease among the scholars. The writing on a slate, moreover, does not stand out so clearly as on paper, and the strain to the eyes is therefore greater.

In the *Times* of February 18 particulars are published of the loss of libraries and museums by Serbia consequent upon the recent invasion by the enemy. In Belgrade King Peter's private library and the Royal collections were ransacked. At Nish, the complete treasures of the National Library, the University Library, and the libraries of the various faculties, which had been removed from Belgrade, were con-

fiscated and sent to Sofia. The library of the Theological College of Prizrend met the same fate. The priceless treasures of the Ethnographical Museum in Belgrade have been disbanded, and are being divided between Austria and Hungary.

THE duty of the nation towards its children was never more serious and imperative than at the present crisis. We are under a grave obligation to raise up an educated generation of men and women to take the place of those who, being in the main the most virile of the nation, will suffer to an unprecedented extent death and disablement in the course of the war. We have found by bitter experience that our past neglect of education has placed us in grave peril, both in respect of scientific military resources and in regard to industrial and commercial enterprise. Yet, despite the indubitable truth of all this, we find that the education committees are being subjected to extraordinary pressure by interested sections of the nation, not only in rural areas, but in industrial centres also, to economise in essential features in the subjects and means of education, and, not content with this, in requiring that the children shall be released from school at an untimely age. In Lancashire it is demanded by textile employers and employed alike that the full-time school age shall be reduced; in a commercial centre like Bradford a like demand is made, and throughout the agricultural areas the cry is that the children shall be placed at the disposal of the farmers. According to a statement made by the President of the Board of Education a few days ago, there are now some 8000 children otherwise legally liable to attend school who have been exempted by various education committees. The Government should in this matter lead the nation and make unmistakably clear that the child-life shall not be exploited, but conserved so that physically and mentally it shall be fitted adequately for the onerous responsibilities which will surely be required of it. The women of the nation have shown how satisfactorily they have responded to the industrial demand, and there is little doubt that they would be found equal under proper economic conditions to the claims of agriculture.

SOCIETIES AND ACADEMIES.

LONDON.

Royal Society, February 17.—Sir J. J. Thomson, president, in the chair.—A. R. Cushman and S. Yagi: The action of cobra venom. The action of cobra venom has generally been supposed to be exerted in part on the central nervous system, in part on the terminations of the motor nerves. It is shown that there are no symptoms of central nervous action in either cold or warm-blooded animals, and that death occurs from paralysis of the motor nerve terminations in striated muscle. In the frog this is accompanied by slowness, and finally arrest of the circulation from a direct action on the heart. In mammals the failure of the respiration is due to the paralysis of the respiratory nerve terminations, but this is often accompanied by the inhalation of saliva, which accelerates asphyxia. The heart is also weakened by quantities of venom greater than the minimum lethal dose. A number of antidotes were examined, without any great success, because no antidote appeared capable of ejecting the venom from its combinations in the tissues.—L. Doncaster: Gametogenesis and sex-determination in the gall-fly, *Neuroterus lenticularis*. Part III. In *N. lenticularis* there are two generations in the year, agamic females appearing in early spring, and sexual females and males in early summer. Previous work had shown that any individual agamic female has only

male or only female offspring, and the object of the present work was to discover the nature of the difference between these two classes of agamic females. Two possible cytological causes might account for the fact that some sexual females produce only male-producing offspring, while others produce only female-producing. If each fly pairs only once, the difference might depend on the existence of two kinds of males, or it might arise through differences in the maturation-processes of eggs laid by the two classes of sexual female. No cytological differences in the spermatogenesis of different males could be detected. The maturation phenomena of the eggs (about 300) of fifteen separate females have been examined, and while they seem to fall into two rather distinct types, the differences are not sufficiently considerable to correlate them with the sex-phenomena with any confidence.—Philippa C. Esdaile: The structure and development of the skull and laryngeal cartilages of perameles, with notes on the cranial nerves. The writer has had the unique advantage of examining in detail a series of six embryo skulls of perameles. The development has been observed and the ossification of the cartilage and membrane bones described and figured. Many questions of interest have been noted, the most important being the affinities and formation of the ala temporalis and its subsequent ossification from cartilage and membrane.—J. C. Bose and S. C. Das: Physiological investigations with petiole-pulvinus preparation of *Mimosa pudica*. The present investigation is to show how an isolated preparation of petiole-and-pulvinus of *Mimosa* may be rendered as efficient for researches on irritability as the nerve-and-muscle preparation of a frog. On isolation of the preparation from the plant, the shock of operation is found to paralyse it. Experimental conditions are described for restoration of excitability which can be maintained uniform for more than twenty-four hours, after which a depression sets in. The rate of fall of excitability becomes rapid forty hours after the operation, the sensibility being finally abolished after the fiftieth hour. For the determination of the rôle played by different parts of the pulvinus in response and recovery, response-records were taken when selective amputation was made of (1) the upper, and (2) the lower, half of the pulvinus. It is shown that the excitability of the upper half is eighty times less than that of the lower. Chemical agents induce characteristic changes in excitability. The responses exhibit fatigue when the period of rest is diminished. The passage of a constant current is found to remove the fatigue. Response is enhanced under exposure to light, and diminished in darkness. Light is shown to exert a direct stimulating action on the pulvinus, independent of photosynthesis. Injury caused by cut or section of the petiole induces a variation in the conducting power. Two different effects are produced, determined by the tonic condition of the specimen. In normal specimens, injury depresses the conducting power; in sub-tonic specimens it enhances it.

PARIS.

Academy of Sciences, January 31.—M. Camille Jordan in the chair.—The President announced the death of Guido Baccelli, correspondant for the section of medicine and surgery, and of Edouard Heckel, correspondant for the section of rural economy.—A. Laveran: Experimental infections of mice by *Leishmania tropica*; a case of infection by the digestive tract. A detailed description of the transmission of the disease to a mouse by a culture administered by the mouth. Three other mice, similarly treated, were not infected.—S. Brodetsky: An analogy between linear differential equations and algebraical equations.—A. Perot: A method of observing the coincidences of two

periodic phenomena (see p. 715).—F. **Jadin** and A. **Astruc**: Manganese in some alpine springs. The quantities of manganese found vary from 0.001 mgr. per litre (Aix-les-Bains) to 0.46 (Saint Gervais). Ferruginous springs contain more manganese than those in the same region free from iron.—H. **Devaux**: The presence of a coating resisting wetting at the surface of particles of sand and of arable soil. If particles of sand, dry or containing up to 0.5 per cent. of water, are dusted on to the surface of water, the greater part of the grains float. If the moisture in the sand amounts to 1 per cent., all the grains immediately sink. The non-wetting of the surface of the sand grain is probably due to the presence of a thin layer of organic matter, as this phenomenon is not shown by calcined sand. Soils behave similarly, and the capillary effects produced by this coating must have an important influence on plant growth.—Henri **Grosheintz**: An installation permitting the javellisation of the whole of the municipal water supply of the town of Thann. The special arrangement for mixing the solution of calcium hypochlorite with the water consists of a small pump connected with the large water lift pump, so that the two make stroke for stroke. In this manner 50 c.c. of the hypochlorite solution is injected per cubic metre of water. The bacteriological examination of the water proved the efficiency of the treatment.

February 7.—M. Camille Jordan in the chair.—L. **Maquenne**: The estimation of reducing substances in the presence of an excess of saccharose. Studies on the choice of temperature of reduction and time of heating, and on the quantity of sugar to be used in the analysis. Details of the titration method recommended are given.—Georges **Fontené**: An extension of Poncelet's theorem relating to polygons inscribed in, or circumscribed about, conics.—M. **Darbois**: Remarks on the preceding communication.—S. **Stoilow**: The integration of linear equations by equations of successive approximation.—J. **Dejust**: The trace of the blades of a hydraulic turbine in which the pressure decreases linearly along trajectories relative to the stream lines.—Albert **Colson**: The irrational character of solubility formulæ and heats of moistening. A reply to a criticism by M. Le Chatelier.—J. L. **Hamonet**: True homologues of glycerol, heptanetriol. The author gives as the definition of a true homologue of glycerol a substance possessing the formula $\text{CH}_2(\text{OH})-(\text{CH}_2)_n-\text{CH}(\text{OH})-(\text{CH}_2)_n-\text{CH}_2(\text{OH})$, and describes the preparation of heptanetriol, in which $n=1$.—Henry de **Varigny**: The erosion of the French Cretaceous cliffs on the Channel. Several streets in Bourg d'Ault are perpendicular to the line of the coast and lead to the edge of the cliff. The changes in length of these streets during the period 1825-1912 have been exactly determined, and show an annual loss of rather more than 26 cm. per annum.—Louis **Gentil**: The existence of recent volcanoes in central Morocco.—Le **Marechal** and M. **Morin**: A new apparatus for the radiosopic localisation of projectiles in the wounded. It is claimed for the instrument described and illustrated that its indications are at least equal to those of the best instruments utilising radiographs, and that no calculation or geometric construction is required.—A. **Lécaillon**: Non-impregnated eggs and parthenogenesis of the silkworm (*Bombyx mori*).

WASHINGTON, D.C.

National Academy of Sciences (Proceedings, No. 1, vol. ii.).—G. F. **Becker**: A possible origin for some spiral nebulae. It is suggested that nebulae may be developed from nebulous streamers or "bacula." Comparison of the theoretical shape of the nebulae at certain

stages of their development with the whirlpool nebula is not unfavourable to the hypothesis.—E. W. **Hilgard**: A peculiar clay from near the city of Mexico. The analysis shows that the predominant base is magnesia. A peculiarity of the clay is its exceptionally high absorptive power for water.—Harlow **Shapley**: Studies of magnitude in star clusters. I.—The absorption of light in space. The examination of the Hercules cluster indicates the conclusion that the selective extinction of light in space is entirely inappreciable, and that probably the non-selective absorption in space is also negligible.—Harlow **Shapley**: Studies of magnitudes in stars clusters. II.—The sequence of spectral types in stellar evolution. The giant second-type stars are present in large numbers in the globular clusters. The results offer difficulties for the conventional scheme of evolution of spectral types, but the difficulties are not so severe for Russell's hypothesis.—R. A. **Millikan** and W. H. **Souder**: Experimental evidence for the essential identity of the selective and normal photo-electric effects. Photo-electric phenomena are not in general conditioned by the presence of a gas. All distinctions between the normal and selective effects in lithium have disappeared.—L. A. **Bauer**: Concomitant changes in terrestrial magnetism and solar radiation. Changes in the earth's magnetism of appreciable amount are found associated with changes in solar radiation. Decreased solar constant is accompanied by increased magnetic constant. Various minor but important correlations are established.—A. G. **Mayer**: Submarine solution of limestone in relation to the Murray-Agassiz theory of coral atolls. By exposing pieces of shell of the mollusc *Cassia* to solution in sea-water for a year under various conditions, it is shown that the rate of solution is too slow to be favourable to the theory that the solvent action of sea-water for limestone is a primary factor in deepening and widening the lagoons of coral atolls.—D. H. **Campbell**: The Archegonium and Sporophyte of *Treubia insignis*, Goebel. *Treubia* is probably on the whole nearer the leafy liverworts than is any other anacrogynous genus.—Aleš **Hrdlička**: Brief notes on recent anthropological explorations under the auspices of the Smithsonian Institution and the U.S. National Museum. The topics treated are: search for Neolithic human remains in south-western Russia; explorations in the Birusa caves and rock shelters on the Yenisei River, Siberia; development of the child among the Negrito, the African negro, the Eskimo, and native Siberians.—A. G. **Mayer**: A theory of nerve-conduction. The theory of nerve-conduction is based upon the phenomena of adsorption. The results lend no support to the theory that the velocity of propagation of nerve impulse is that of a shear in the substance of the nerve.—A. L. **Kroeber**: Zuñi culture sequences. The author gathered a large number of potsherds in and near Zuñi, and is able to make a tentative chronological classification of the objects.—H. S. **Jennings**: The numerical results of diverse systems of breeding. The proportions of the population which are found after n generations arising from continued breeding in various ways are tabulated for twenty-four different methods of mating.—Raymond **Pearl**: The effects of feeding pituitary body (anterior lobe) substance and corpus luteum substance to growing chicks. The commencement of the laying period in pullets is neither retarded nor accelerated by feeding pituitary and corpus substance, but the body growth is retarded.—R. **Goldschmidt**: A preliminary report on further experiments in inheritance and determination of sex. The article states a number of new results found by the author in continuing his earlier work on the interbreeding of gipsy moths. Every gradation of intersexualism from a normal female to a normal male, and from a male

three-fourths of the way toward the female has been obtained.—Raymond Pearl and S. W. Patterson: The degree of inbreeding which exists in American Jersey cattle. American Jersey cattle are about one-half as intensely inbred when eight generations are taken into account as would be the case if continued brother x sister breeding had been followed. In general, register of merit animals are less intensely inbred than the ordinary population.—G. A. Miller: Upper limit of the degree of transitivity of a substitution group. The degree of transitivity of a substitution group of degree n which does not include the alternating group of this degree is always less than $5/2\sqrt{n}-1$.—F. D. Adams and W. J. Dick: The extension of the Montana phosphate deposits northward into Canada. An account of the explorations carried out to ascertain whether phosphate-bearing rocks extend northward from Utah, Idaho, and Montana into Canada. In some places such an extension has been found.

BOOKS RECEIVED.

Royal Botanic Gardens, Kew. Bulletin of Miscellaneous Information. Additional Series ix. The Useful Plants of Nigeria. Part iii. Pp. 343-536. (London: H.M.S.O.; Wyman and Sons, Ltd.) 3s. 6d.

The Investigation of Rivers. By Dr. A. Strahan, N. F. MacKenzie, Dr. H. R. Mill, and Dr. J. S. Owens. Final Report. Pp. 93. (London: Royal Geographical Society.) 3s. 6d. net.

The Universe and the Atom. By M. Erwin. Pp. 314. (London: Constable and Co., Ltd.) 8s. 6d. net.

Madras Government Museum. The Foote Collection of Indian Prehistoric and Protohistoric Antiquities. Catalogue Raisonné. By R. B. Foote. Pp. vii+262. (Madras: Government Press.) 3s.

Madras Government Museum. Catalogue of the Prehistoric Antiquities from Adichanalur and Penumbair. By A. Rea. Pp. xiii+49+plates xiii. (Madras: Government Press.) 2s. 3d.

Hopwood's Living Pictures. By R. B. Foster. New edition. Pp. x+377. (London: The Hatton Press, Ltd.) 6s. net.

Memoirs of the Geological Survey. Special Reports on the Mineral Resources of Great Britain. Vol. i., Tungsten and Manganese Ores. By H. Dewey and C. E. N. Bromehead. Pp. iv+59. Vol. ii., Barytes and Witherite. By R. G. Carruthers and others. Pp. iv+93. Vol. iii., Gypsum and Anhydrite, and Celestine and Strontianite. By Dr. R. L. Sherlock and B. Smith. Pp. 57. (London: H.M.S.O.; E. Stanford, Ltd.) 1s., 1s. 6d., and 1s. respectively.

DIARY OF SOCIETIES.

THURSDAY FEBRUARY 24.

ROYAL SOCIETY, at 4.30.—Mathematical Contributions to the Theory of Evolution XIX. Second Supplement to a Memoir on Skew Variation: Prof. Karl Pearson.—The Relative Combining Volumes of Hydrogen and Oxygen: F. P. Burt and E. C. Edgar.—Speed Effect and Recovery in Slow-speed Alternating Stress Tests: W. Mason.—The Ignition of Gases by Impulsive Electrical Discharge: W. M. Thornton.

ROYAL INSTITUTION, at 3.—The Milky Way and Magellanic Clouds: Sir F. W. Dyson.

CHILD STUDY SOCIETY, at 6.—Psychological Problems arising out of the War: C. Burt.

INSTITUTION OF MINING AND METALLURGY, at 5.30.—The Conelomerates of the Witwatersrand: E. T. Mellor.—A Pioneer Bucket Dredge in Northern Nigeria: H. F. Nicholls.—Antimony Production in Hunan Province, South China: A. S. Wheler.

FRIDAY, FEBRUARY 25.

ROYAL INSTITUTION, at 5.30.—The Commerce of Thought: Sir A. Quiller Couch.

SATURDAY, FEBRUARY 26.

ESSEX FIELD CLUB (at the Essex Museum, Stratford), at 3.—Grasses: J. Groves.

TUESDAY, FEBRUARY 29.

ROYAL INSTITUTION, at 3.—The Plant and the Soil—Nature: Dr. E. J. Russell.

WEDNESDAY, MARCH 1.

ENTOMOLOGICAL SOCIETY, at 8.—Specific and Mimetic Relationships in the Genus *Heliconius*, L.: Dr. Harry Eltringham.

SOCIETY OF PUBLIC ANALYSTS, at 8.—The Manufacture of English Chemical Filter Paper: E. J. Bevan and W. Bacon.—Pink Colour on the Surface of Margarine: A. W. Knapp.—A Rapid Method for the Estimation of Fat in Powders: S. B. Phillips.—A New Colour Reaction for Aloes: C. E. Stacy.

INSTITUTION OF ELECTRICAL ENGINEERS (Students' Section), at 7.45.—Suggested Applications of Science to Warfare: R. E. Dickinson.

THURSDAY, MARCH 2.

ROYAL SOCIETY, at 4.30.—Probable Papers: The Antiseptic Action of Substances of the Chloramine Group: J. B. Cohen, H. D. Dakin, M. Daufresne and J. Kenyon.—The Structure of the Dicyanodot Skull: I. J. B. Sallas and Prof. W. J. Sallas.—Analyses of Agricultural Yield. Part III. The Influence of Natural Environmental Factors upon the yield of Egyptian Cotton: W. L. Balls.—The Function of Chlorophyll, Carotin and Xanthophyll: A. J. Ewart.

ROYAL INSTITUTION, at 3.—Recent Excavations in Mesopotamia—The Northern Capitals, Nineveh and Asshur: Prof. L. W. King.

CHILD STUDY SOCIETY, at 6.—The Danish Child at School: A. E. Hayes.

LINNEAN SOCIETY, at 5.—Larva of *Giardia (Lambia) intestinalis* from cases of Diarrhoea in Soldiers, the Infections being contracted in Flanders: Dr. Annie Porter.—Larval and Post-Larval Stages of *Janus lalandii*: Dr. J. D. F. Gilchrist.—The August Heliozoan Plankton of some North Worcestershire Pools: B. Millard Griffiths.—The Distribution of the Box-tree, *Buxus sempervirens*: Dr. Otto Stapf.

FRIDAY, MARCH 3.

ROYAL INSTITUTION, at 5.30.—Corona and other Forms of Electric Discharge: Prof. S. P. Thompson.

GEOLOGISTS' ASSOCIATION, at 7.30.—The Oil-fields of Trinidad: V. C. Illing.

CONTENTS.

	PAGE
The Oxford Aristotle. By E. H. Strange	699
Mechanics and Engineering Technology. By A. J. M.	700
Metamorphic Geology	701
Our Bookshelf	702
Letters to the Editor:—	
Scottish "Elephant" Designs.—Ludovic MacLellan Mann; Prof. G. Elliot Smith, F.R.S.	703
The Remarkable Warmth of January, 1916.—Chas. Harding	703
Lipoids and Vitamines in Margarine and Butter.—J. de Ruiter	704
Science Scholarships.—Sidney Skinner	704
Science in the Civil Service.—T. Ll. Humberstone	705
The Place of Science in Education.—D. Hill	705
Latin as a Universal Language.—Dr. W. H. D. Rouse	705
Submarines. (Illustrated.) By Prof. C. V. Boys, F.R.S.	706
The Caliph's Last Heritage. (Illustrated.)	707
French Views of the Synthetic Dye Problem	708
Sir William Turner, K.C.B., F.R.S.	709
Notes	710
Our Astronomical Column:—	
Perrine's Comet (1896 VII.)	715
Comparison of Pendulums	715
The Variation of Latitude	715
Dinosaurs. (Illustrated.)	716
Ventilation of Soils	716
Lace-Wing Flies	717
The Position of Science: Memorial from the Imperial College	717
Science and Government	717
Polarised Light and its Applications to Engineering. (Illustrated.) By Prof. E. G. Coker	718
University and Educational Intelligence	723
Societies and Academies	724
Books Received	726
Diary of Societies	726

Editorial and Publishing Offices:

MACMILLAN & CO., LTD.,
ST. MARTIN'S STREET, LONDON, W.C.

Advertisements and business letters to be addressed to the Publishers

Editorial Communications to the Editor.

Telegraphic Address: PHUSIS, LONDON.

Telephone Number: GERRARD 8830.



Astronomical Photography

The qualities required in the dry plates used for astronomical work are of great importance, and can only be provided by the plate maker of long experience. They may be summarized as follows:—

1. They must have uniformity; it is of no use to supply a plate having certain characteristics, and next delivery to offer a plate entirely different.
2. They must have keeping power.
3. They must be capable of development at fairly high temperature.
4. They must have extreme sensitiveness.
5. They must be capable of giving good contrast, of very fine grain and suffering as little as possible from irradiation, that is, the image must spread as little as possible with increasing exposure.

It should be remarked that 4 and 5 are incompatible, maximum speed will not allow of minimum grain, but plates fulfilling all the above requirements, so far as it is possible, have been manufactured for many years and supplied to the leading observatories by Messrs. Wratten & Wainwright, Ltd., the oldest established plate makers in the world. They know exactly what is required for this work.

Write for Descriptive List (mentioning "Nature") to

Kodak Ltd. (Wratten Division),
Kingsway, London, W.C.

MARTINDALE'S Pure Chemicals Reagents and Apparatus

FOR
LABORATORIES

AT CLOSEST PRICES.

Additional factory in course of construction for manufacture of chemicals hitherto obtained from the Continent. Enquiries solicited.

W. MARTINDALE,
Manufacturing and Analytical Chemist,
10 NEW CAVENDISH STREET, LONDON, W.

Phones: 4688 Gerrard; 1797 Paddington.
When writing please mention NATURE.

C. F. CASELLA & CO. Ltd.

CAPT. SANKEY'S METAL BENDING TESTER,

for rapidly determining, in the workshop, the quality of steel and other metals.

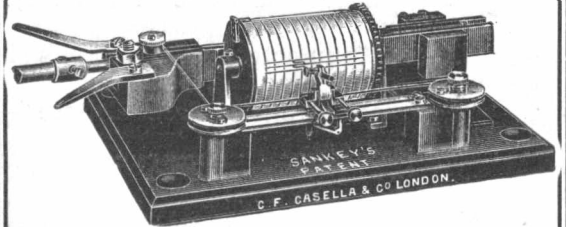

Supplied to:

GOVERNMENT DEPARTMENTS.—India, Australia, New South Wales, Queensland, Crown Agents, Etc.

UNIVERSITIES & TECHNICAL COLLEGES.—London, Edinburgh, Glasgow, Birmingham, Leicester, Egypt, Russia, New Zealand, Hong Kong, Etc.

ENGINEERS, Etc.—Austin Motor Co., Pierce-Arrow Motor Co., J. Stone & Co., Gt. Western Railway, Marconi Co., Brit. Engine Insurance Co., Etc., Etc.

PAMPHLET ON APPLICATION.

**WANSEY STREET WORKS, WALWORTH,
LONDON, S.E.**

Gold Medals and Awards, London, 1862; Paris, 1867; Philadelphia, 1876; Inventions Exhibition, London, 1885; 9 Medals Paris, 1900; Grand Prize, Franco-British Exhibition, 1908; Rio de Janeiro, 1909; 4 Grand Prizes and Gold Medal, Turin, 1911.

JAS. J. HICKS

(Incorporated with W. F. STANLEY & CO., Ltd.),

8, 9 & 10 HATTON GARDEN, LONDON

SCIENTIFIC INSTRUMENT MAKER

to the various Departments of H.M. Home, Indian, and Colonial Governments, many Foreign Governments, and the Principal Observatories, Universities, and Colleges throughout the World.

Manufacturer of Standard Meteorological and Scientific Instruments of every description, including Clinical Thermometers.

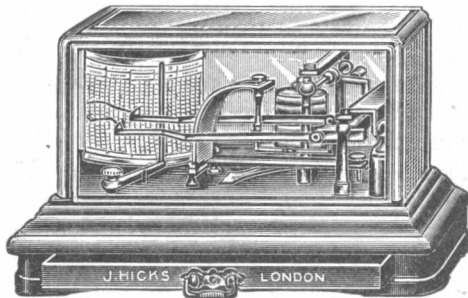

Self-Recording Aneroid
Barometers and Thermometers,
or Combined and Recording
on one Chart (as illustrated).
UNIQUE DESIGNS. NEW PATTERNS.

Catalogues Post Free. (State which required.)

ANY KIND OF SCIENTIFIC INSTRUMENT MADE TO ORDER

Special Terms to Colleges, Institutions, and Members of Scientific Societies.

Quotations submitted for Laboratory Outfits or Single Instruments.

THERMOMETERS FOR STUDENT WORK A SPECIALITY.

The following are some of the topical articles which have appeared in NATURE since the outbreak of the war:—

- "The War—and After."—Sept. 10, 1914.
 "Glass for Optical Purposes."—Oct. 1, 1914.
 "Science and the State."—Oct. 29, 1914.
 "The Place of Science in Industry."—Nov. 12, 1914.
 "The Manufacture of Dyestuffs in Britain."—Jan. 21, 1915.
 "Synthetic Drugs in Great Britain."—Jan. 28, 1915.
 "The Manufacture of Dyestuffs."—Feb. 11, 1915.
 "Chemistry and Industry."—Feb. 18, 1915.
 "The Manufacture of Dyestuffs."—Feb. 25.
 "Science and Industry."—Mar. 18.
 "Scientific Factors of Industrial Success."—Mar. 25.
 "Supplies of Laboratory and Optical Glass Apparatus."—Mar. 25.
 "The War and British Chemical Industry."—April 1.
 "The Position of the Organic Chemical Industry."—April 1.
 "British Supply of Drugs and Fine Chemicals."—April 15.
 "The Supply of Optical Glass."—May 6.
 "Science and the State."—May 20.
 "An Advisory Council on Industrial Research."—May 20.
 "The Mobilisation of Science."—June 17.
 "Aiming with the Rifle."—June 24.
 "Problems of Airship Design and Construction."—July 1.
 "Science in the Service of the State."—July 8.
 "A Consultative Council in Chemistry."—July 8.
 "The Use of Cotton for the Production of Explosives."—July 15.
 "Munition Metals."—July 15.
 "The Products of Coal Distillation."—July 15.
 "Science and Munitions of War."—July 22.
 "Chemical Fire - Extinguishers."—July 22.
 "Cotton as a High Explosive."—July 29.
 "The War and Chemical Industry."—July 29.
 "The Government Scheme for the Organisation and Development of Scientific and Industrial Research."—July 29.
 "Modern Munitions of War."—July 29.
 "The Promotion of Research by the State."—Aug. 5.
 "The Gas Industry and Explosives."—Aug. 19.
 "Future Competition with Germany."—Aug. 26.
 "The World's Supply of Potash."—Sept. 16.
 "Science in the War and After the War."—Oct. 14.
 "Science in National Affairs."—Oct. 21.
 "Science and Nescience."—Nov. 4.
 "Co-operation in Scientific Research."—Nov. 11.
 "Science for All."—Nov. 18.
 "Science and the Public."—Nov. 25.
 "Work and Worth."—Dec. 2.
 "National Needs."—Dec. 9.
 "Industrial Research Laboratories."—Dec. 16.
 "Science and War."—Dec. 16.
 "The 'Wheat Problem' and Synthetic Nitrates."—Dec. 23.
 "National Economy in Fuel."—Dec. 23.
 "Scientific Research and Chemical Industry."—Dec. 30.
 "The Scientific Organisation of Industries."—Dec. 30.
 "Merit and Reward."—Jan. 6, 1916.
 "Germany's Aims and Methods."—Jan. 27, 1916.
 "Optical Sights for Rifles."—Feb. 3, 1916.
 "Defects and Remedies."—Feb. 10, 1916.
 "Optical Instruments and the Ministry of Munitions."—Feb. 10, 1916.
 "Science in the Public Schools and the Civil Service."—Feb. 17, 1916.
 "The Organisation of Scientific Research."—Feb. 17, 1916.

Any one number will be sent by post on receipt of its published price, plus postage.

OFFICE OF "NATURE," ST. MARTIN'S STREET, LONDON, W.C.

JAMES SWIFT & SON

Optical and Scientific Instrument Makers.

Contractors to all Scientific Departments of H.M. Government.
Grands Prix, Diplomas of Honour, and Gold Medals at London, Paris, Brussels, etc.

APOCHROMATIC MICRO. OBJECTIVES.

As we are in possession of a quantity of ab-olutely clear white Fluorite, we are now manufacturing the following series of Apochromats:

DRY SERIES.			OIL IMMERSIONS.		
Focal length.	N.A.	Price.	Focal length.	N.A.	Price.
1 inch	0.30	£4 10 0	1/2 inch	1.35	£8 10 0
3/4 "	0.30	3 0 0	3/8 "	1.40	10 0 0
1/2 "	0.65	4 0 0	1/4 "	1.35	8 10 0
3/8 "	0.95	6 0 0	1/8 "	1.40	10 10 0

NATURE says: "Compare very favourably in all respects with similar lenses of other makers at double the price."

81 TOTTENHAM COURT ROAD, LONDON, W.

WATKINS & DONCASTER,

Naturalists and Manufacturers of
CABINETS AND APPARATUS

FOR COLLECTORS OF INSECTS, BIRDS' EGGS AND SKINS,
MINERALS, PLANTS, &c.

N.B.—For excellence and superiority of Cabinets and Apparatus references are permitted to distinguished patrons, Museums, Colleges, &c.

A LARGE STOCK OF INSECTS, BIRDS' EGGS AND SKINS.

**SPECIALITY.—Objects for Nature Study,
Drawing Classes, &c.**

Birds, Mammals, &c., Preserved and Mounted by First-class Workmen true to Nature.

All Books and Publications (New and Second-hand) on Insects, Birds' Eggs, &c., supplied.

36 STRAND, LONDON, W.C.

(Five Doors from Charing Cross.)

FULL CATALOGUE POST FREE

MICROSCOPICAL SECTIONS OF TYPICAL ROCKS.

12 Sedimentary and Metamorphic, in box ... 18/-
12 Igneous, in box 18/-

2 Sets, as above, 35/-

Sections to order, 1/6 each.

RUSSELL & SHAW,

38 GT. JAMES STREET, BEDFORD ROW, LONDON, W.C.

MICROSCOPIC SECTIONS OF ROCKS & MINERALS,

EITHER FROM STOCK OR CLIENTS' OWN MATERIALS.
Descriptions and Reports made at an inclusive charge if desired. Apply—

JAMES R. GREGORY & CO.,
Mineralogists, &c.

139 FULHAM ROAD, SOUTH KENSINGTON, S.W.

'Phone: Western 284t.

Telegrams: "Meteorites, London."

See highly favourable editorial notice, *Nature*, July 11, 1912, p. 477.

The "J.R.B." ADJUSTABLE CURVE RULE

A GREAT IMPROVEMENT UPON
ANYTHING YET MADE.

PRICE 7/6

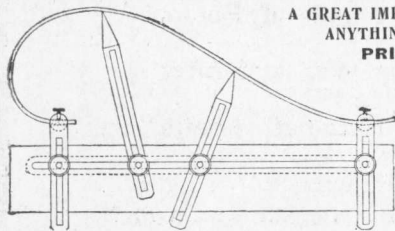

It allows of ANY CURVE, Concave, Convex, or Combined, being described, works with PERFECT SMOOTHNESS, and is ENTIRELY FREE FROM JOINTS—with the attendant kinks.

Write for Illustrated Descriptive Circular, post free from the
SOLE MAKER:

W. H. HARLING, Mathematical, Drawing, and Surveying
Instrument Manufacturer,
47 FINSBURY PAVEMENT, LONDON, E.C.

LIVING SPECIMENS FOR THE MICROSCOPE.

Volvox, Spirogyra, Desmids, Diatoms, Ameba, Arcella, Actinosphaerium, Vorticella, Stentor, Hydra, Floscularia, Stephanoceros, Melicerta, and many other specimens of Pond Life. Price 1s. 6d. per Tube, Post Free. Helix pomatia, Astacus, Amphioxus, Rana, Anodon, &c., for Dissection purposes.

THOMAS BOLTON,

25 BALSALL HEATH ROAD, BIRMINGHAM.

MARINE BIOLOGICAL ASSOCIATION OF THE UNITED KINGDOM. THE LABORATORY, PLYMOUTH.

The following animals can always be supplied, either living or preserved by the best methods:—

Sycon; Clava, Obelia, Sertularia; Actinia, Tealia, Caryophyllia, Alcyonium; Hormiphora (preserved); Leptoplana; Lineus, Amphiporus, Nereis, Aphrodite, Arenicola, Lanice, Terebella; Lepas, Balanus, Gammarus Ligia Mysis, Nebalia, Carcinus; Patella, Buccinum, Eledone, Pectens Bugula, Crisia, Pedicellina, Holothuria, Asterias, Echinus, Salpa (preserved), Scyllium, Rais, &c., &c.

For prices and more detailed lists apply to
Biological Laboratory, Plymouth.

THE DIRECTOR.

GLASS BLOWING

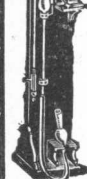

ALL KINDS OF SCIENTIFIC AND EXPERIMENTAL GLASS BLOWING carried out quickly and correctly from rough sketch at Moderate Charges.

ANY FORM OF GLASS APPARATUS REPAIRED.
DEMONSTRATIONS given here. or at Colleges, &c.

H. HELM, 66 HATTON GARDEN, LONDON.
Telephone 2512 Holborn.

ACTUAL MAKER of ALL KINDS of X Ray, Geissler and other Vacuum Tubes, Mercury Pumps, High Frequency Electrodes, &c.
List free.

NOTICE.—Advertisements and business letters for "Nature" should be addressed to the Publishers; Editorial Communications to the Editor. The telegraphic address of "Nature" is "Phusis," London. Telephone—Gerrard, 8830.

SUBSCRIPTIONS TO "NATURE."

	£	s.	d.	To all Places Abroad:—	£	s.	d.
Yearly	1	8	0	Yearly	1	10	6
Half-yearly (26 Numbers)	0	14	6	Half-yearly (26 Numbers)	0	15	6
Quarterly (13 Numbers)	0	7	6	Quarterly (13 Numbers)	0	8	0

(A charge of 6d. is made for changing Scotch and Irish Cheques.)

Cloth Cases for binding "Nature" are issued at 1s. 6d. each, and can be sent post free for 1s. 9d.

NET CHARGES FOR ADVERTISEMENTS.

	£	s.	d.		£	s.	d.
First Two Lines in Column	0	2	6	One Sixth Page, or One Third Col.	1	3	6
Per Line after	0	0	9	Quarter Page, or Half a Column	1	15	0
One Sixteenth Page, or Eighth Col.	0	10	0	Half a Page, or a Column	3	5	0
One Eighth Page, or Quarter Col.	0	18	6	Whole Page	6	6	0

For the re-direction of replies to advts. a charge of 3d. per advt. is made.

Cheques and Money Orders should be Crossed and made payable to MACMILLAN & CO., Limited.

OFFICE: ST. MARTIN'S STREET, LONDON, W.C.

RHEOSTATS

NEW LIST NOW READY

☞ *NATURE* says :
"The list is one
of the most com-
plete we have
seen."

☞ See editorial notices
Feb. 3, page 633,
and Feb. 10, page
658.

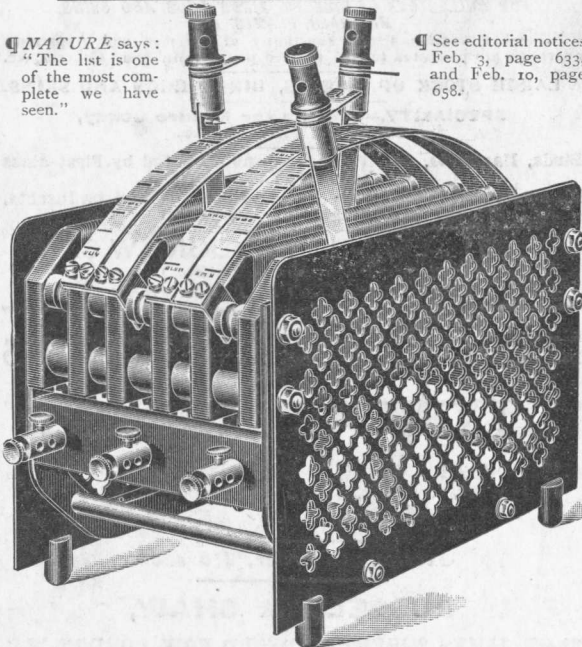

ISENTHAL & CO. (Dept. 1) **DENZIL WORKS, WILLESDEN, LONDON, N.W.**
Contractors to the Admiralty, War Office, India Office, Colonial Office, Postmaster General, &c.

ALUNDUM REFRACTORIES AND LABORATORY WARE

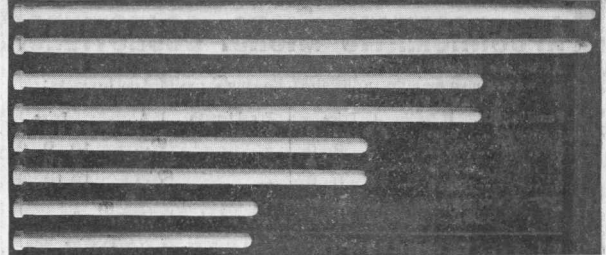

PYROMETER TUBES.

Alundum pyrometer tubes are impervious to gases under normal pressures through a wide range of temperatures. They have a high deformation point which, in connection with their imperviousness and high thermal conductivity, are very valuable in pyrometric work. These tubes will stand rapid changes of temperature and are surprisingly long-lived when treated in a manner similar to the porcelain tube.

Prices and particulars of above, also
CRUCIBLES, TUBES, COMBUSTION BOATS, ELECTRIC FURNACE CORES, FILTER DISCS, PLATES, EXTRACTION THIMBLES, MUFFLES, REFRACTORY CEMENTS, &c.,
on application to the
Sole Agents for the Alundum Refractories :

TOWNSON & MERCER.

LTD.,
34 CAMOMILE STREET, LONDON, E.C.

SCIENTIFIC INSTRUMENTS

OF ALL DESCRIPTIONS.

LABORATORY APPARATUS

- Beakers
- Burettes
- Condensers
- Crucibles
- Evaporating Basins
- Flasks
- Filter Papers
- Nitrometers
- Test Tubes
- Thermometers
- Tubing
- Etc. Etc.

PHILIP HARRIS & CO., LTD. (1913)
BIRMINGHAM
(ENGLAND.)

BRITISH MANUFACTURE

We are ready to supply
PORCELAIN EVAPORATING BASINS, CRUCIBLES, MORTARS, GLASS BEAKERS, FLASKS, Etc., NICKEL CRUCIBLES AND BASINS, FILTER PAPERS, METRICAL WEIGHTS & BALANCES,
as per circulars Br, 171a to 178,
which may be had on application.

We have a large and well-assorted stock of
MUNKTELL'S SWEDISH ASHLESS FILTER PAPERS for Analytical Work.
Particulars and Prices on Application.

A. GALLENKAMP & CO., Ltd.
Contractors to the War Office, Colonial and Indian Governments, Crown Agents for the Colonies, London County Council, &c. On the Admiralty List.
Members of the British Laboratory Ware Association, Ltd.
19 & 21 Sun Street, London, E.C.