

Biblioteka Główna i OINT
Politechniki Wrocławskiej



100100234221

Dobek. zu F. 344

10/3. 10

Wilk

A 405 III

~~II~~

~~20~~
2



V. D. 3.

ATLAS

ZUR

ZEITSCHRIFT FÜR BAUWESEN.

HERAUSGEGEBEN

IM

MINISTERIUM DER ÖFFENTLICHEN ARBEITEN.

REDACTIONS - COMMISSION:

H. HERRMANN, J. W. SCHWEDLER, O. BAENSCH, H. OBERBECK, F. ENDELL,
OBERBAUDIRECTOR. GEH. OBERBAURATH. GEH. OBERBAURATH. GEH. OBERBAURATH. GEH. BAURATH.

REDACTEUR:

L. v. TIEDEMANN,

REGIERUNGS- UND BAURATH IM KÖNIGLICHEN MINISTERIUM DER ÖFFENTLICHEN ARBEITEN.

JAHRGANG XXXIV.

1911.1702.



632

BERLIN 1884

VERLAG VON ERNST & KORN

(GROPIUS'SCHE BUCH- UND KUNSTHANDLUNG)

90 WILHELMSTRASSE

(NÄCHST DEM ARCHITECTENHAUSE).



123



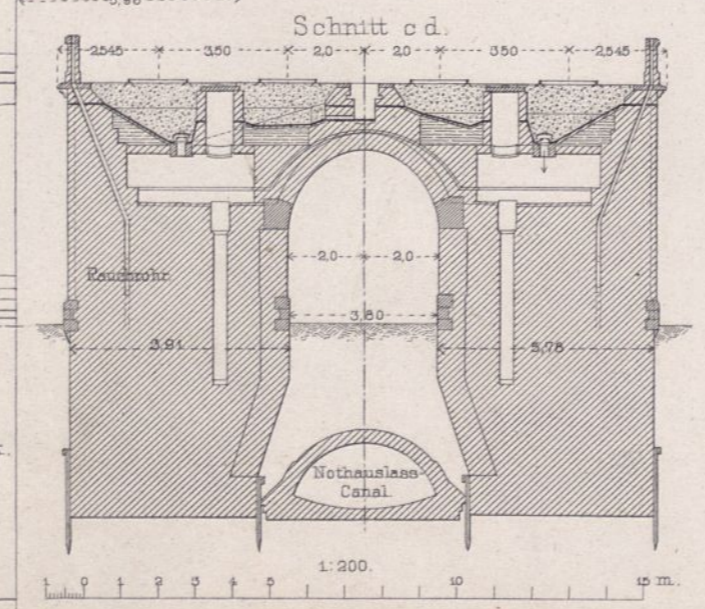
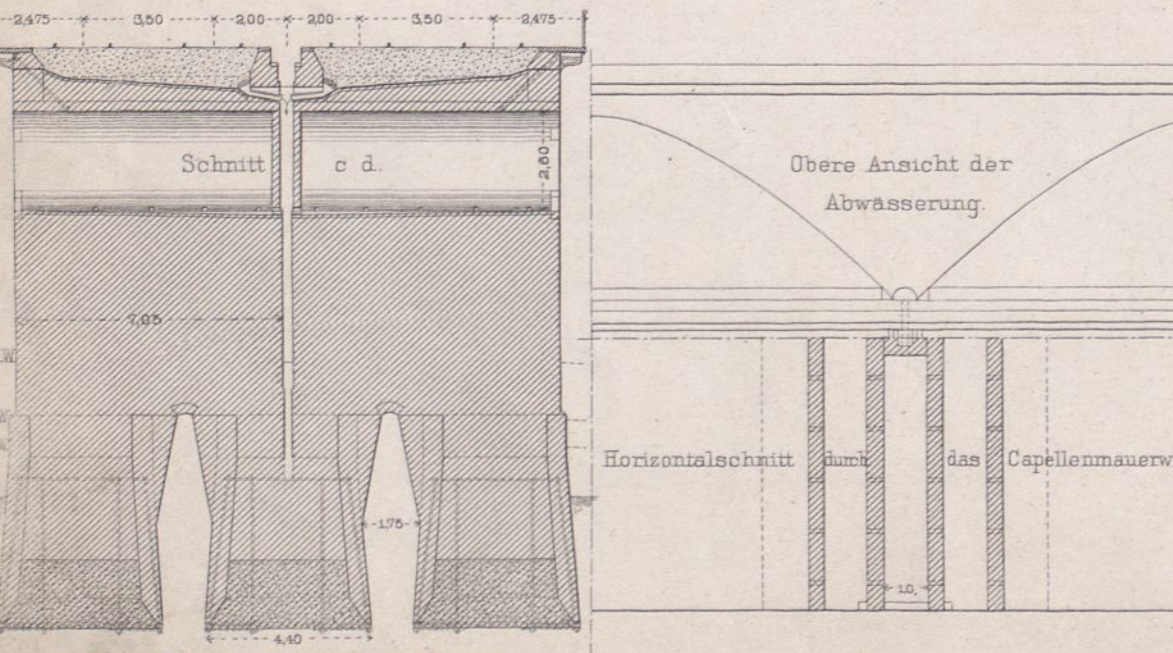
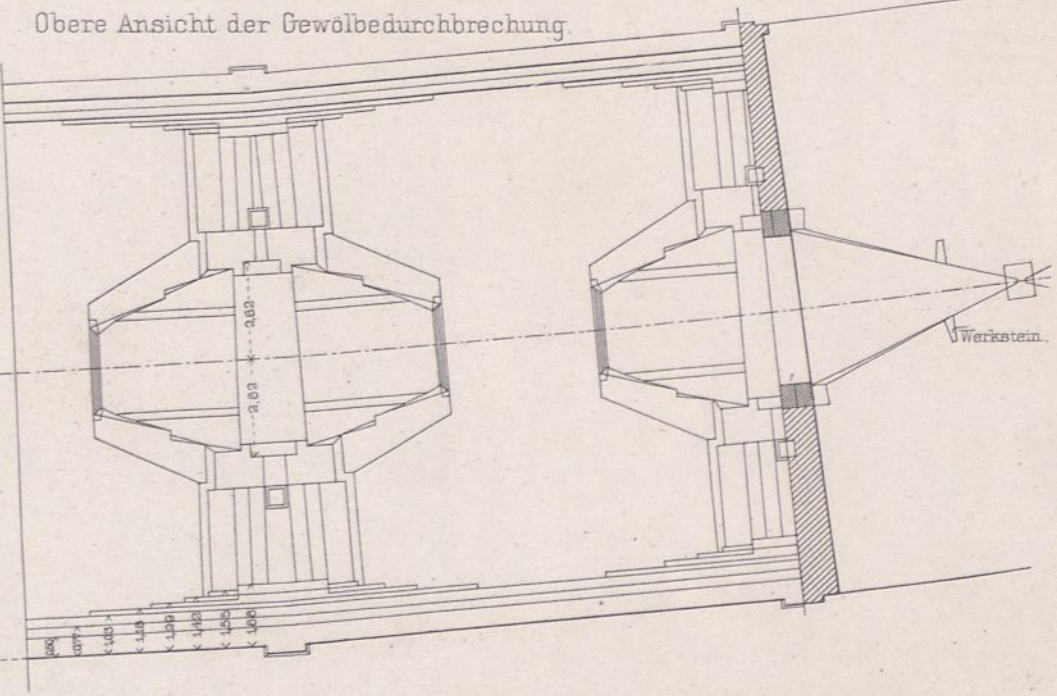
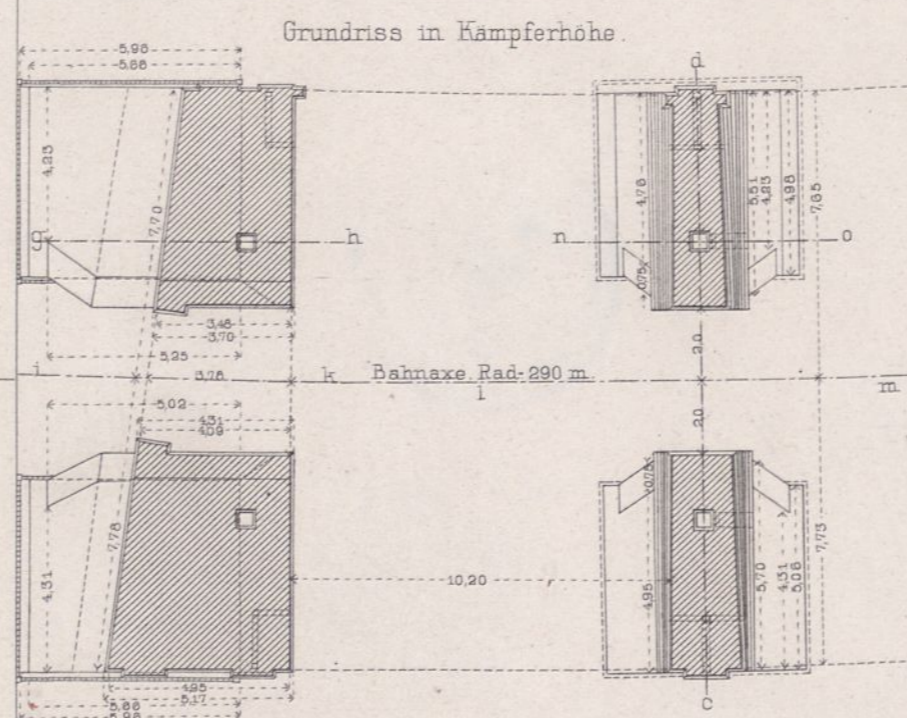
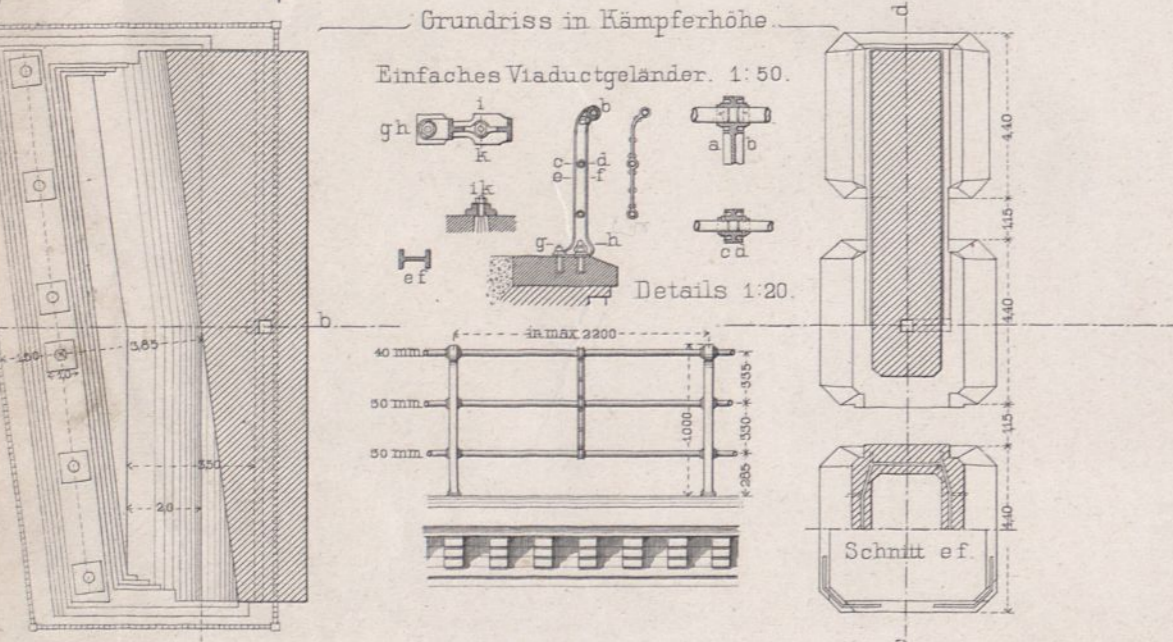
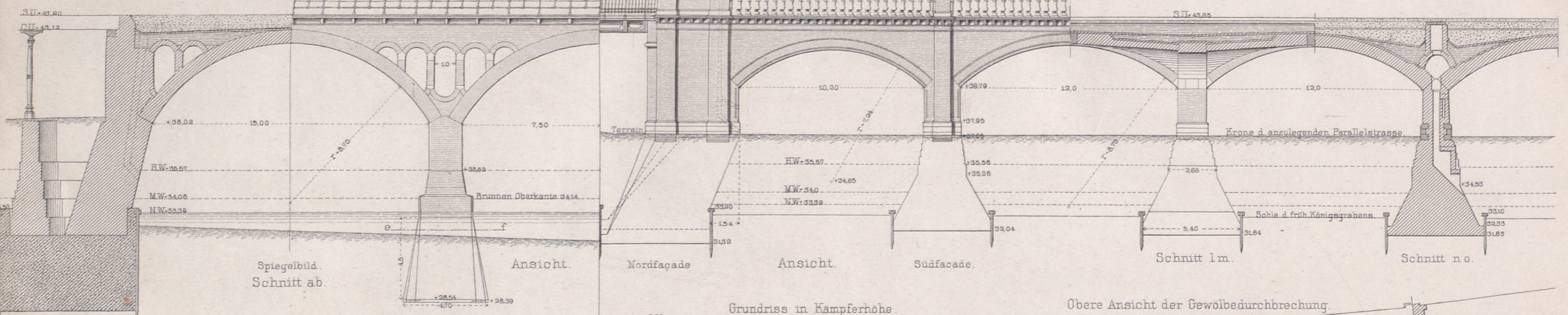

- /// Beton
- /// Werkstein
- /// Concret
- /// Kies

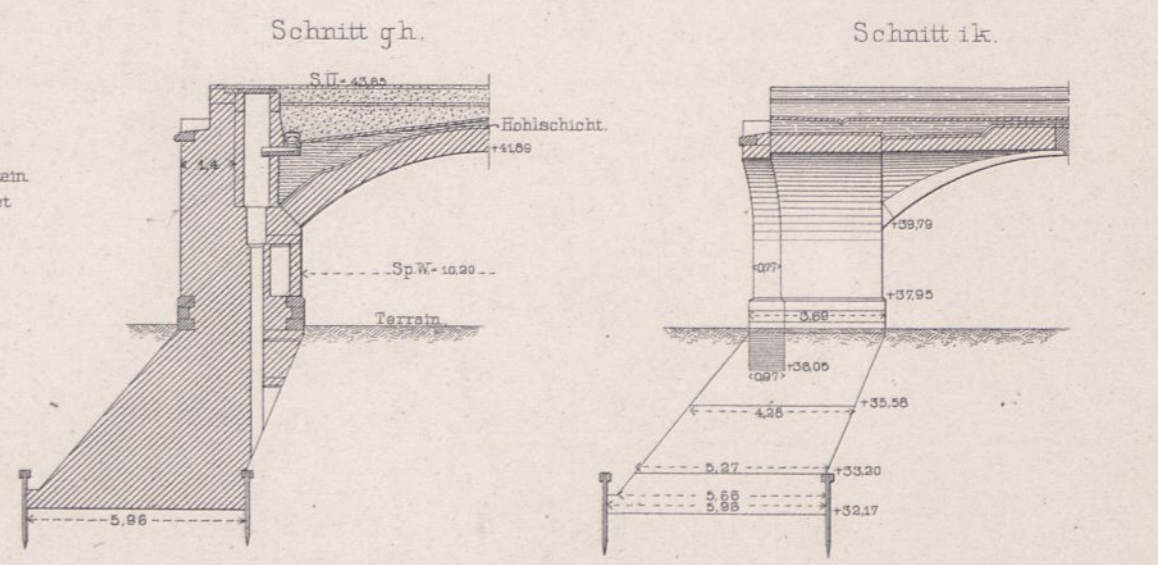

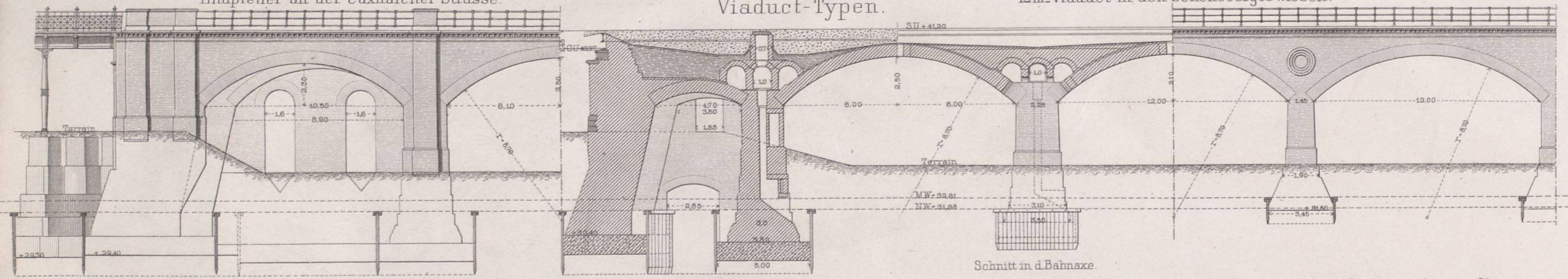

Schnitt in d. Bahnaxe.

Schnitt AB.

Viaduct zwischen Cuxhafener Strasse u. Charlottenburger Chaussee.

Viaduct zwischen Cuxhafener Strasse u. Charlottenburger Chaussee.

- /// Beton
- Werkstein
- Concret
- ⊞ Kies

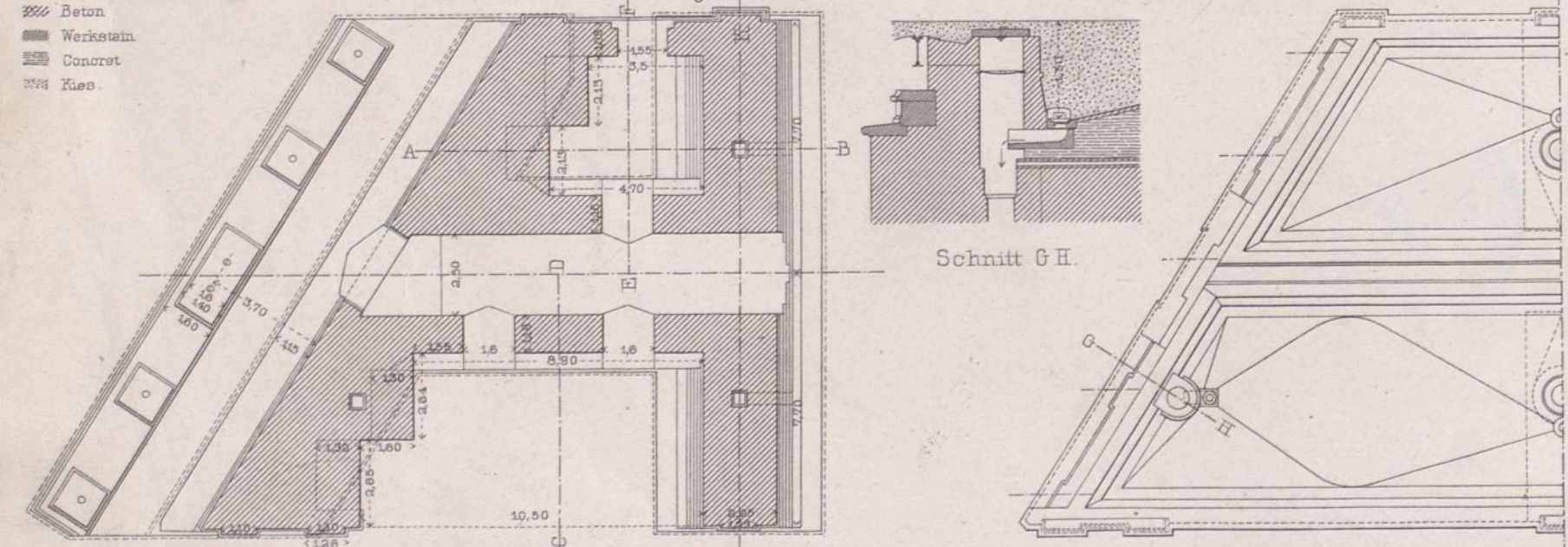

Grundriss in Kämpferhöhe.

Schnitt G.H.

Obere Ansicht der Abwässerung.

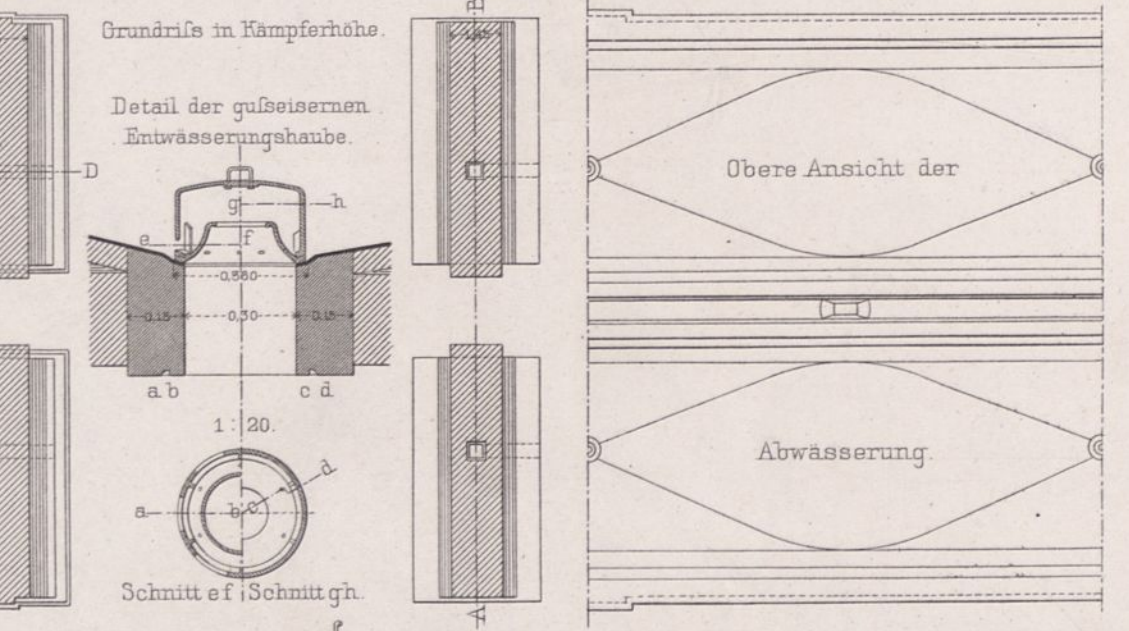

Grundriss in Kämpferhöhe.

Detail der gußeisernen Entwässerungshaube.

Obere Ansicht der

Abwässerung.

Schnitt ef | Schnitt gh.

1:20.

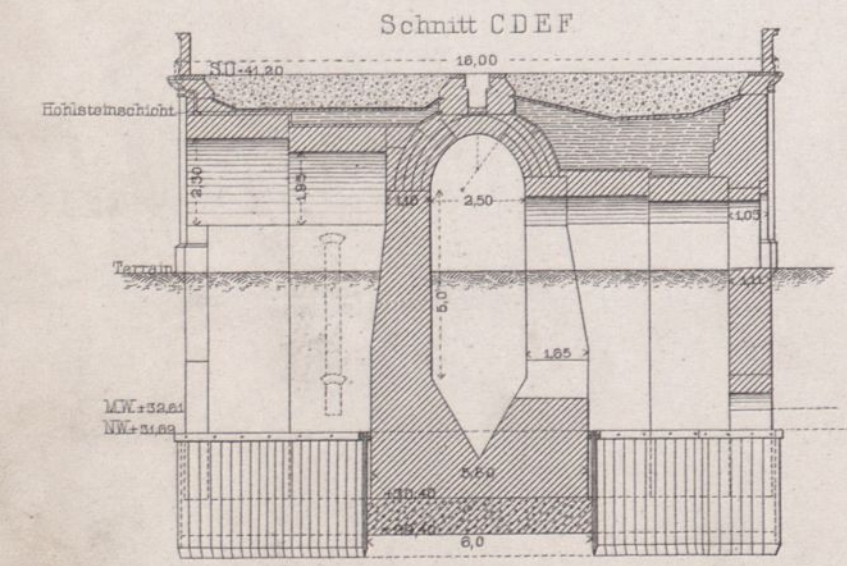

Schnitt CDEF

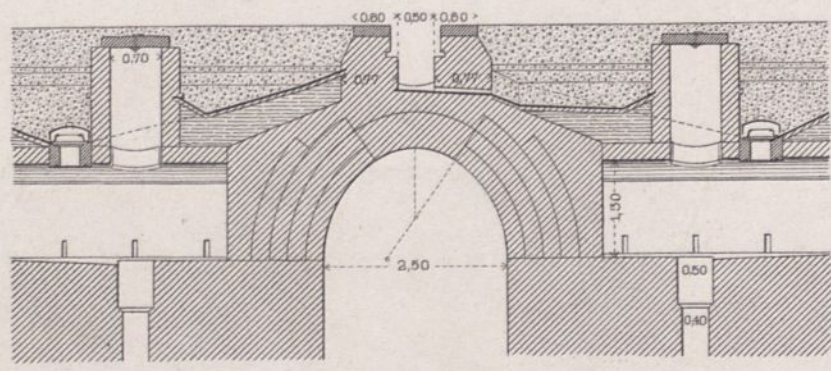

Schnitt JK 1:100.

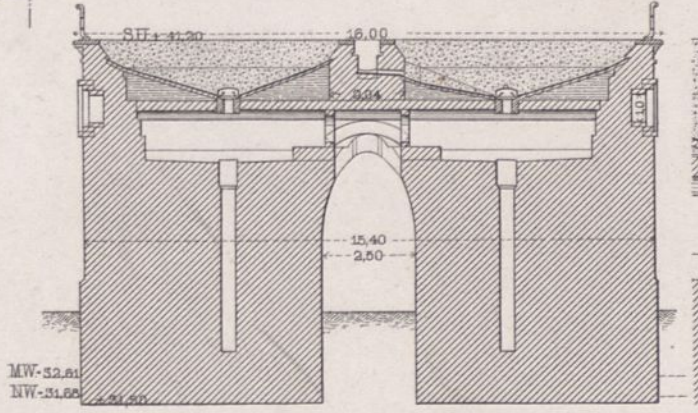

Schnitt AB.

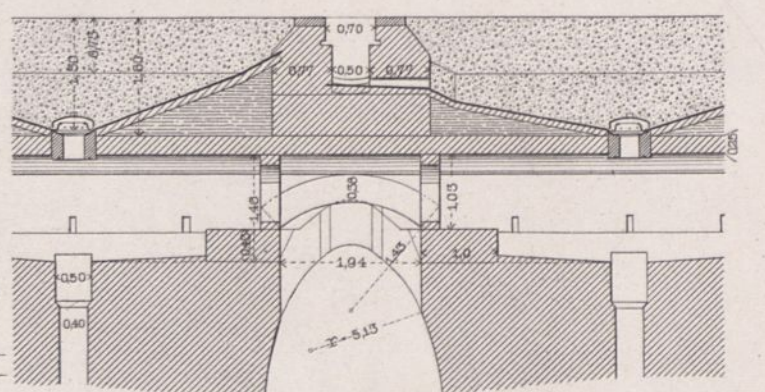

Detail zu Schnitt AB, 1:100.

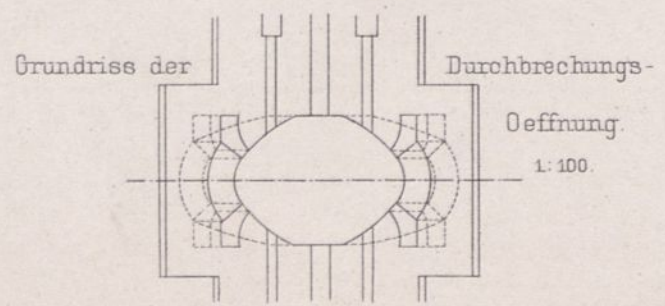
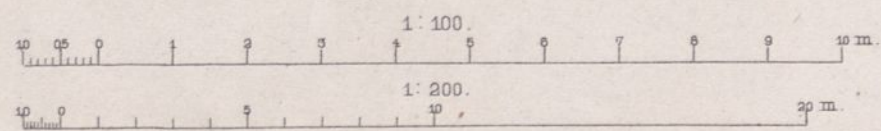

1:100.

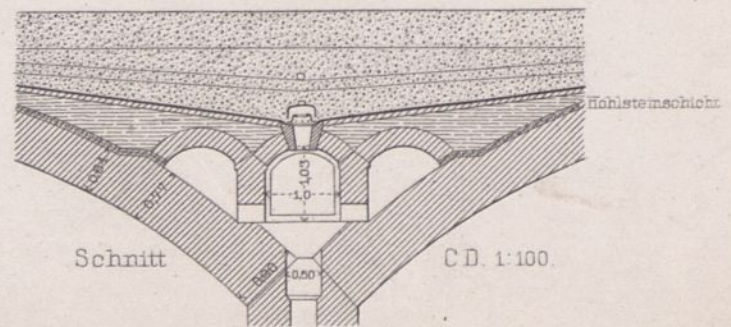

Schnitt

C.D. 1:100.

Brücke über die Spree
an der Museumsinsel.
Langenansicht.

Berliner Stadt-Eisenbahn.

Brücke über den Schiffahrts canal
zwischen d Berlin-Charlottenb Chaussee u d Garten-Ufer.
Langenansicht.

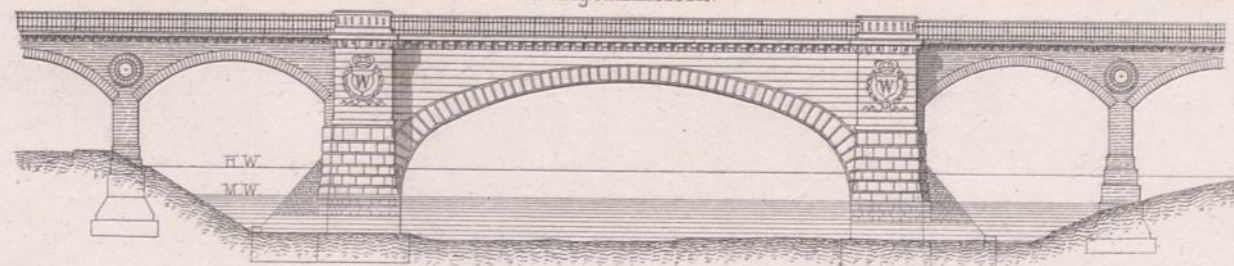
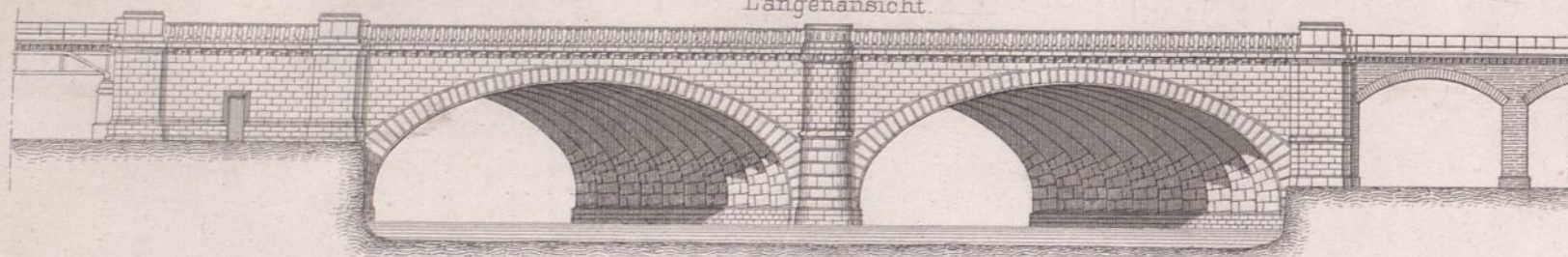

ab. Langenschnitte cd.

ab. Langenschnitte cd.

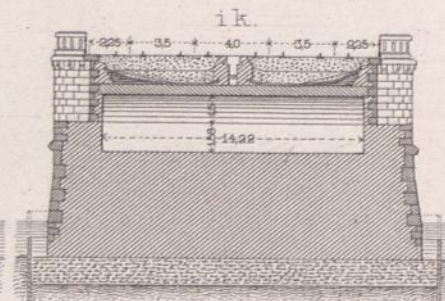
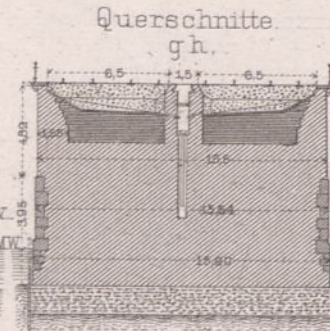
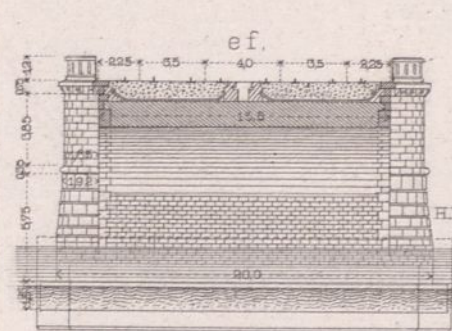
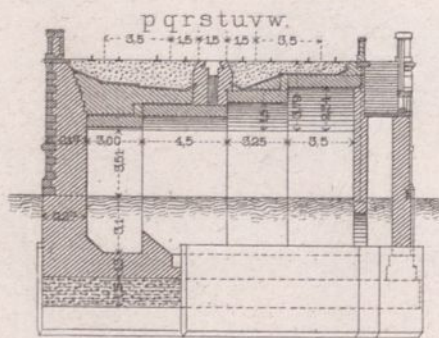
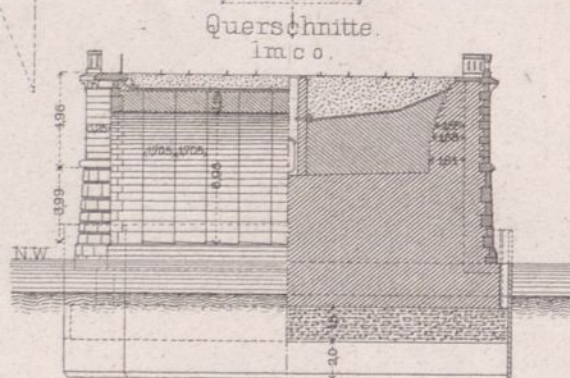
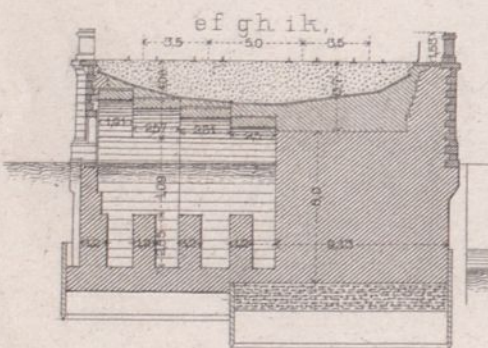
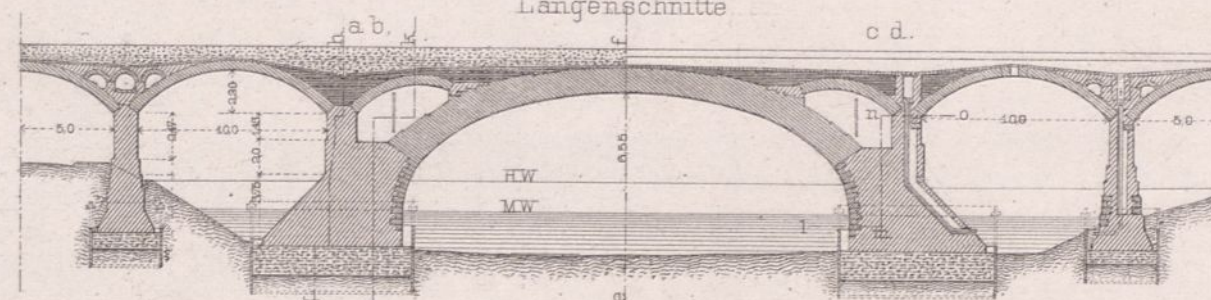
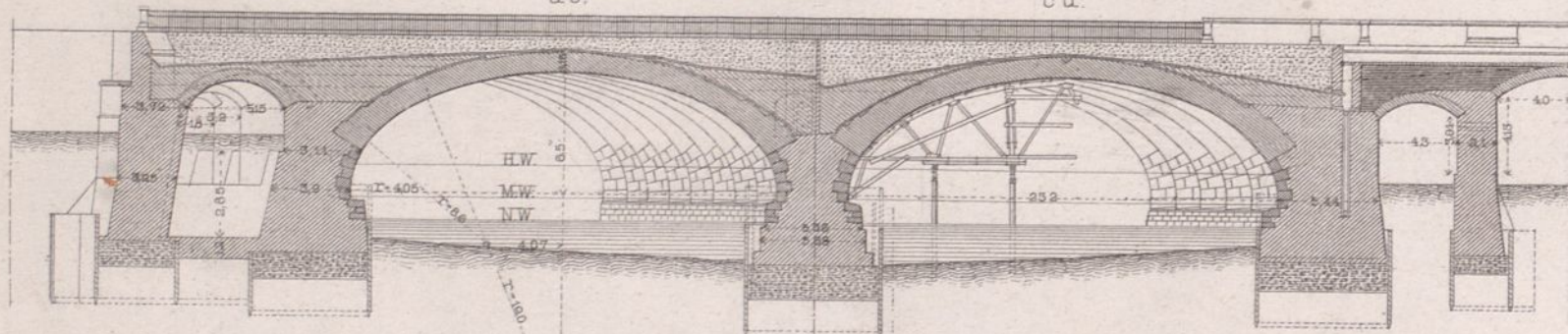

unter Weglassung der Hintermauerung. Oberansichten mit Abwässerung.

mit Abwässerung. unter Weglassung d. Hintermauerung. Horizontalschnitt durch d. Entlastungsraum.

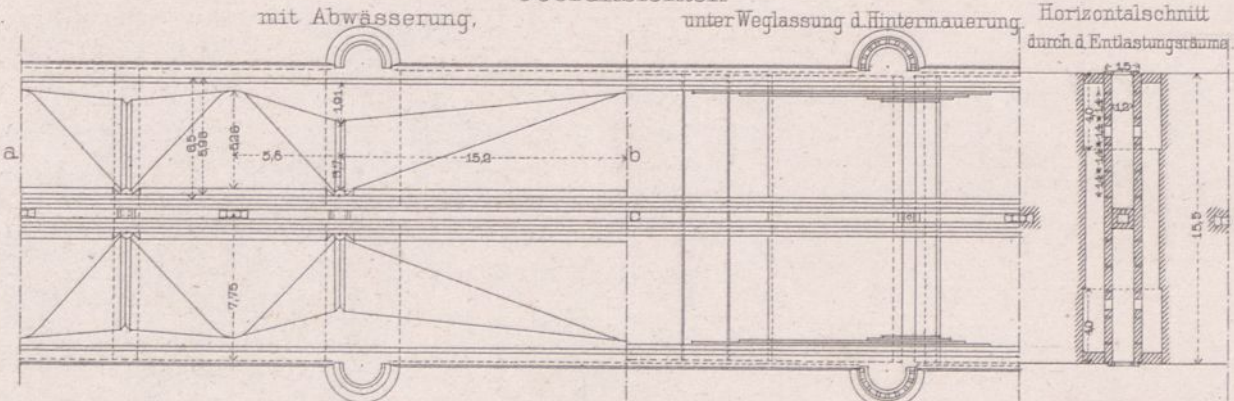
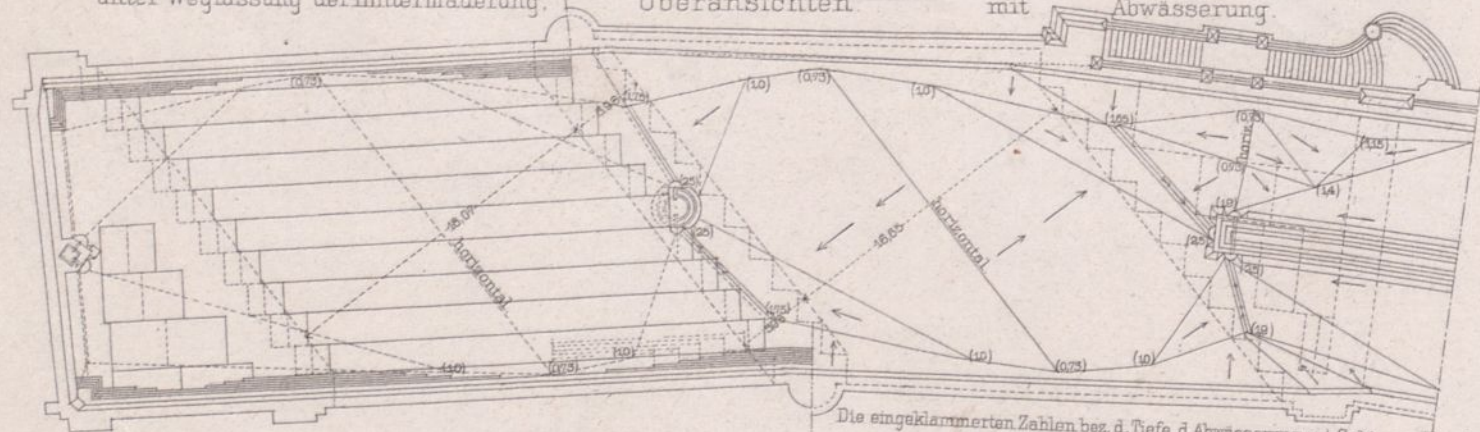

Horizontalschnitt in Mittelwasserhöhe.

in Kämpferhöhe. oberhalb des Gewölbes. nach l m n o. in Kämpferhöhe.

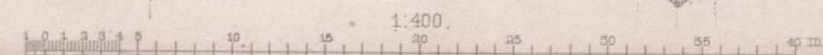
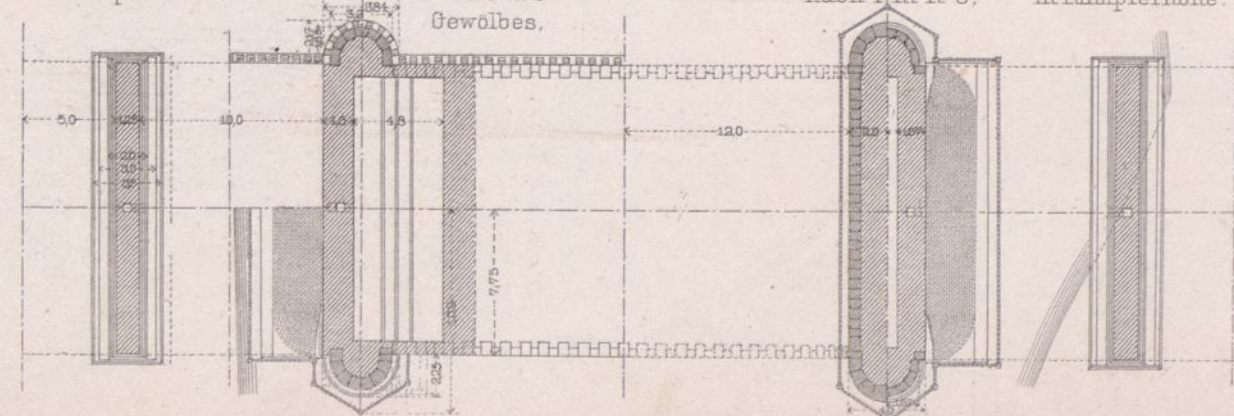
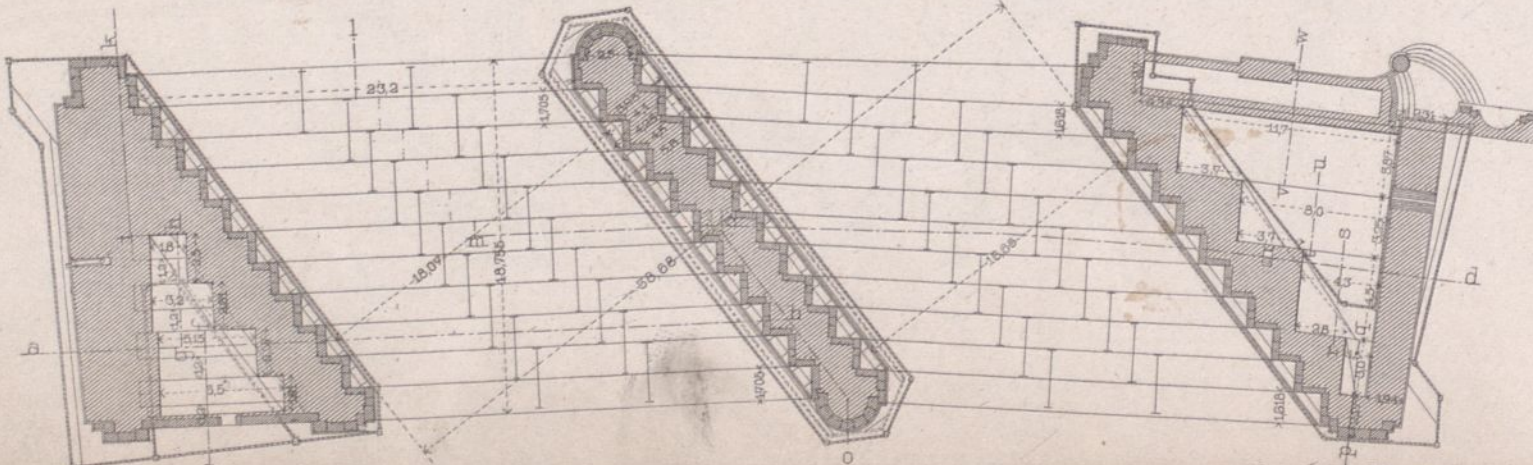

Spreerücke am Schiffbauerdamm.

Ansicht.

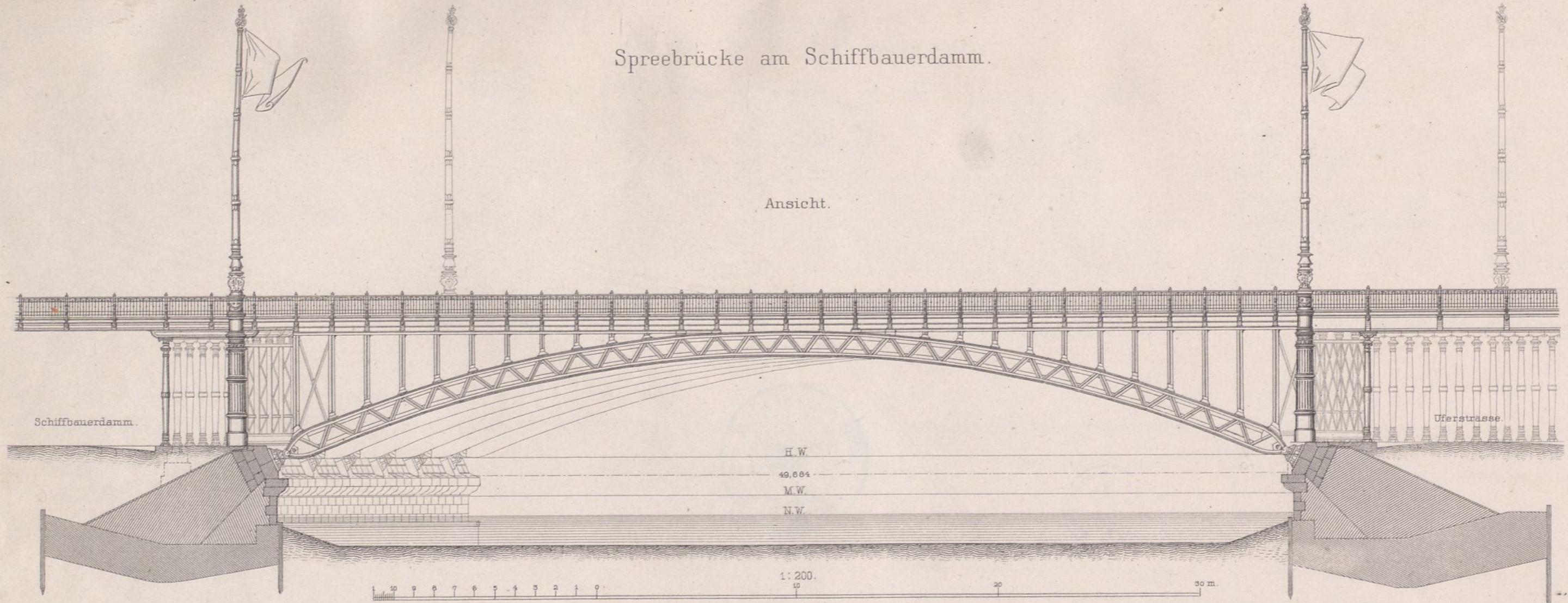

Verticale Nr. 6. Seitenansicht.

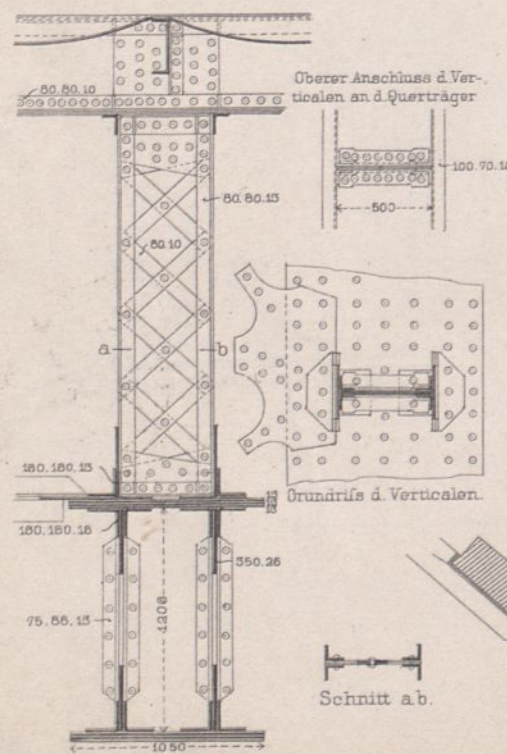

Endpfeiler am Schiffbauerdamm.

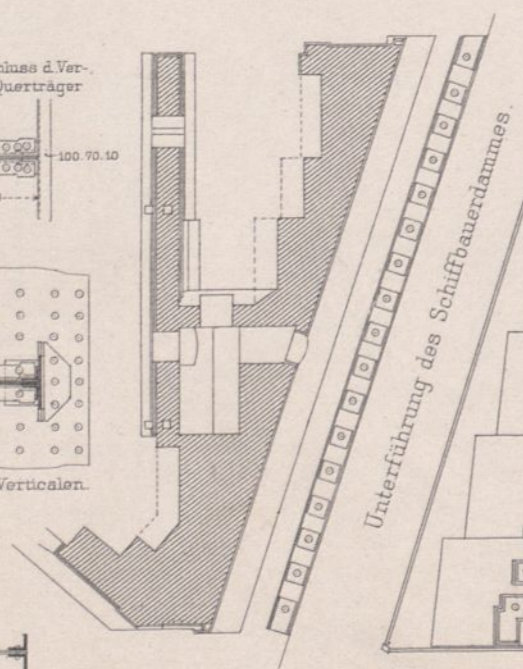

Grundrißs.

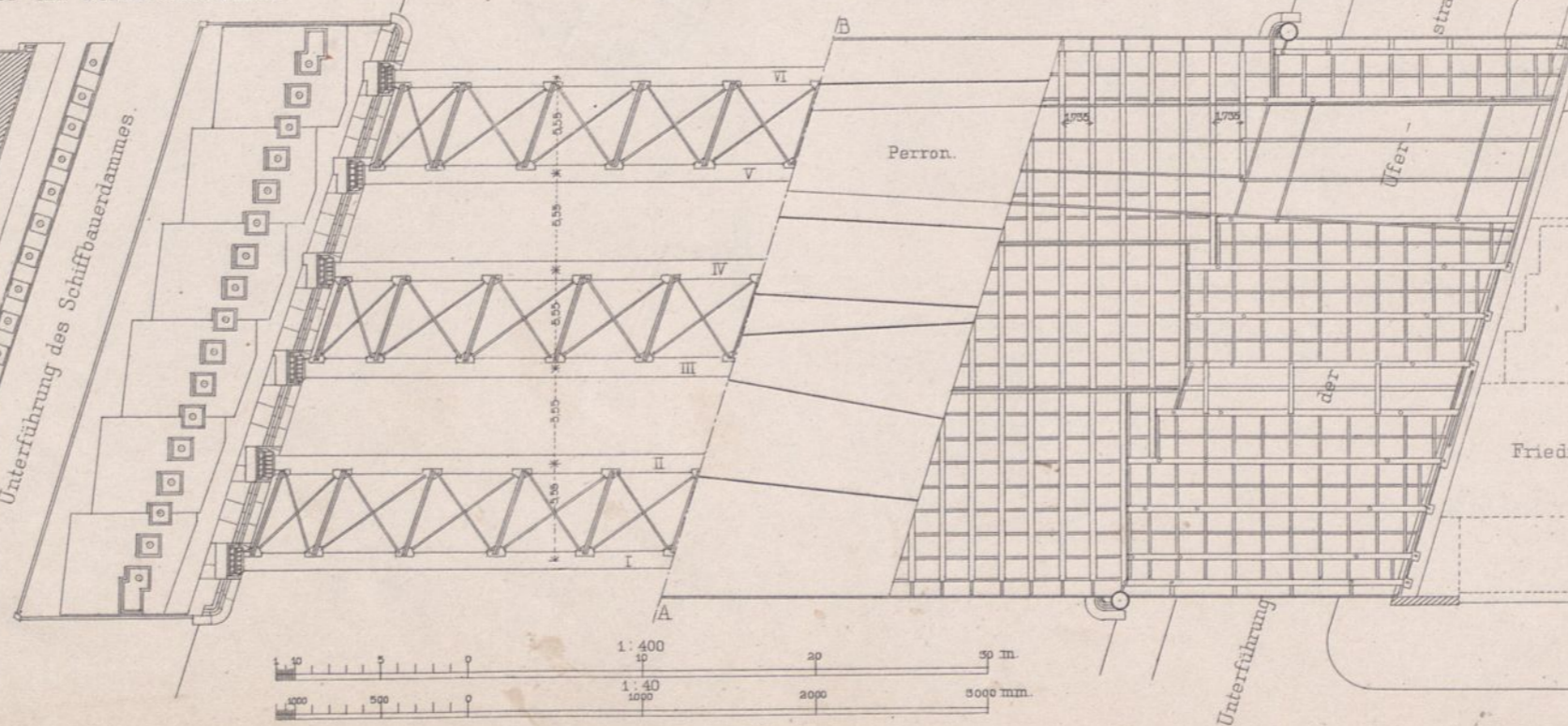

V. Nr. 6. Vorderansicht, Schnitt.

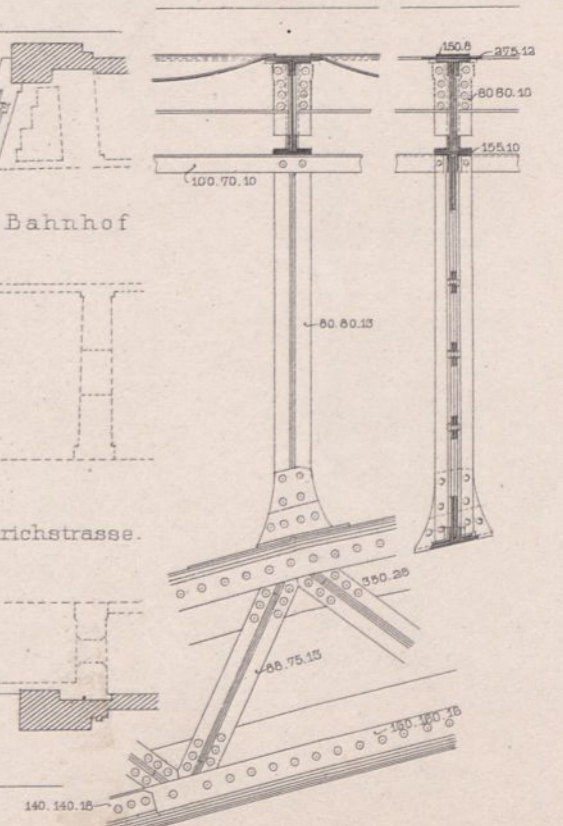

Berliner Stadt-Eisenbahn.
Spreerücke am Schiffbauerdamm.

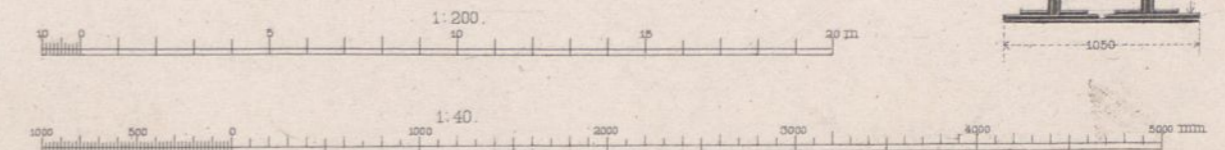
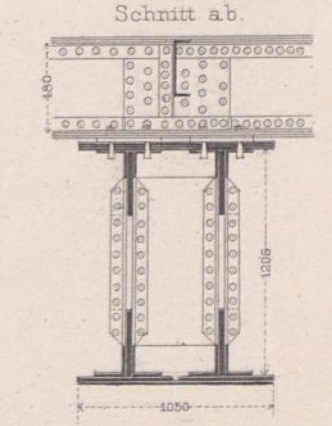
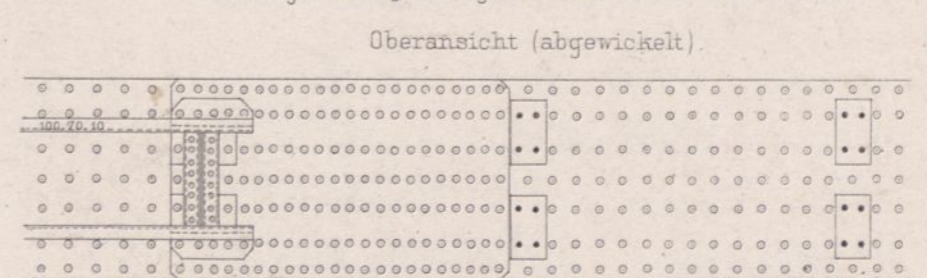
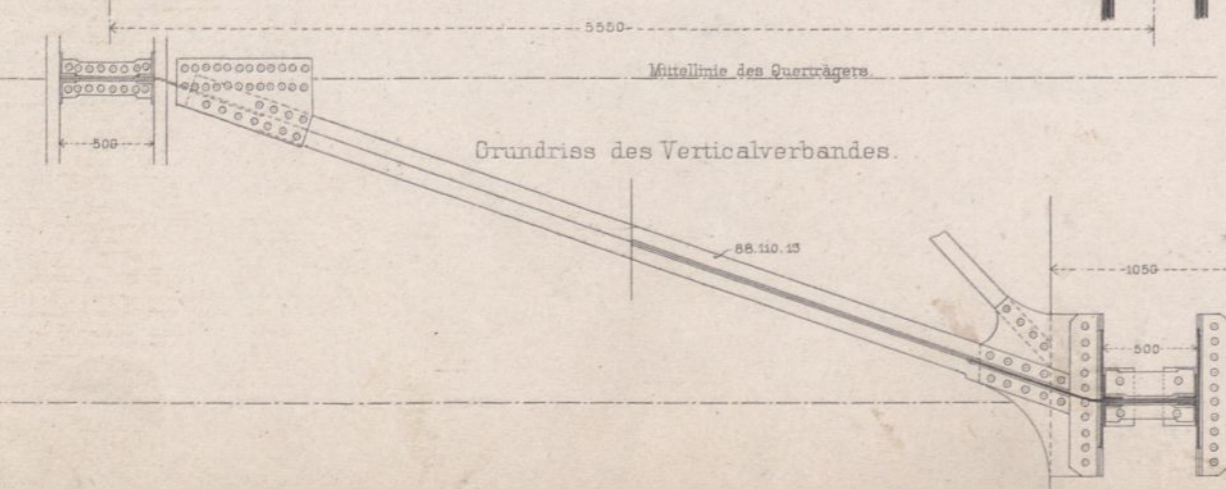
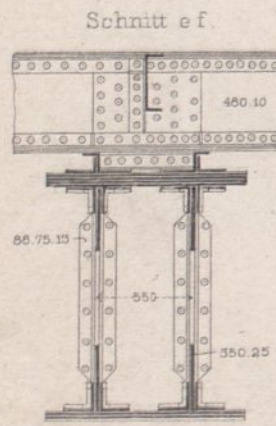
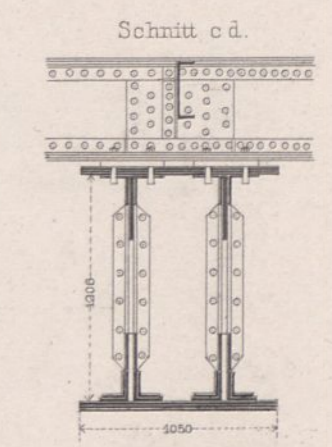
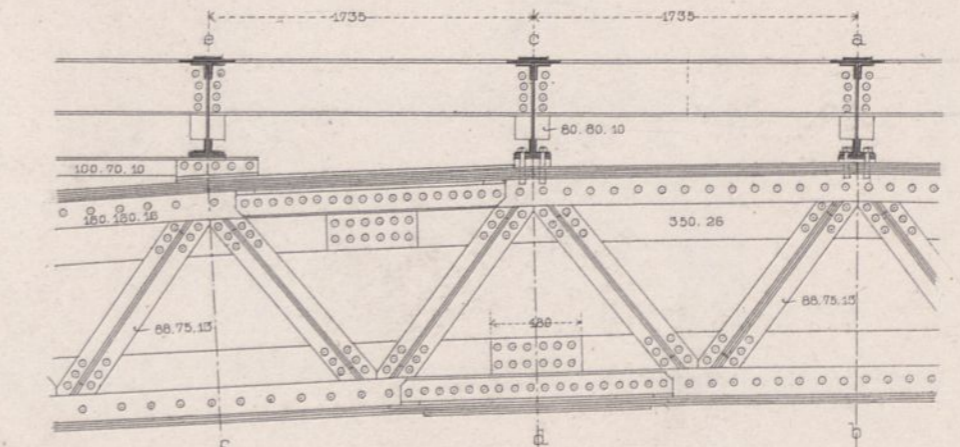
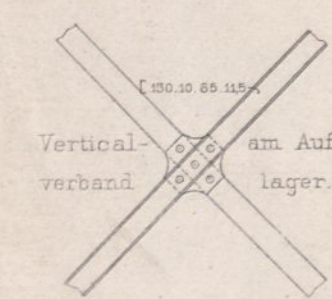
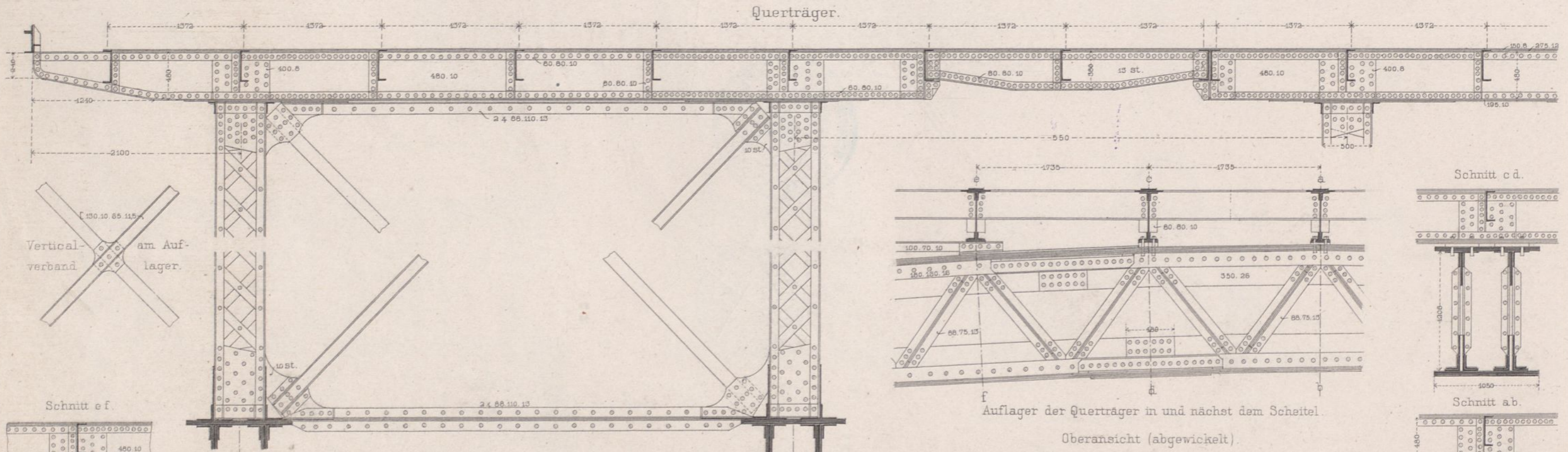
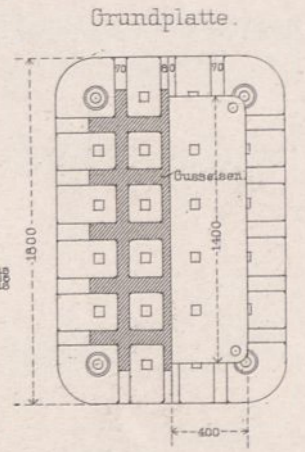
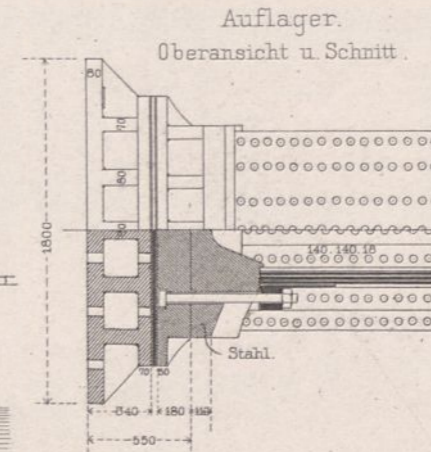
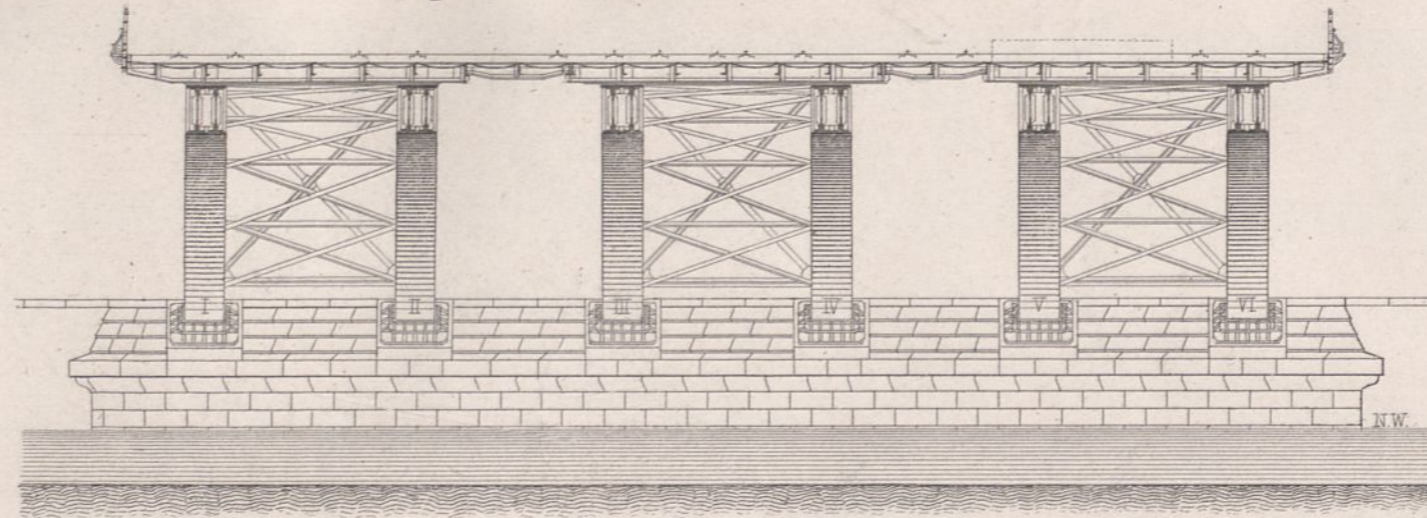
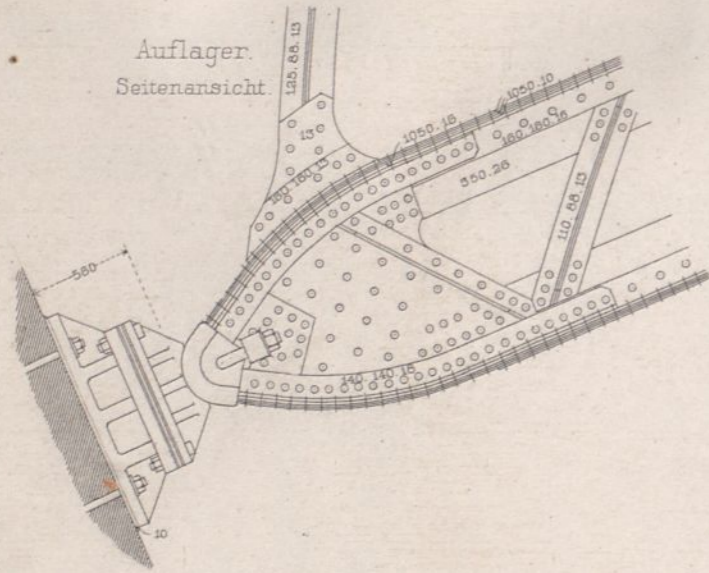

Ansicht der Nordfront.

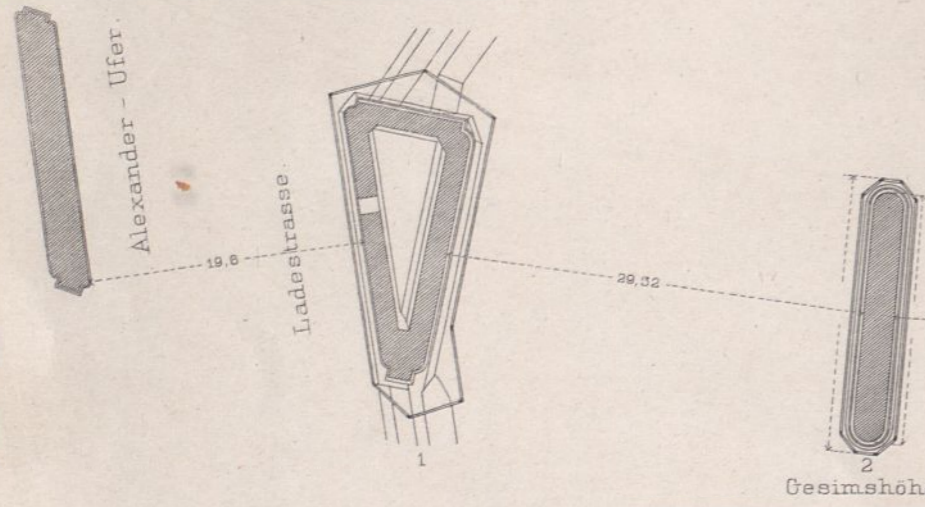
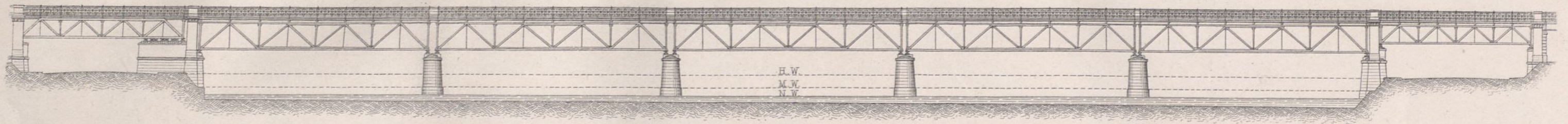

Grundriss.

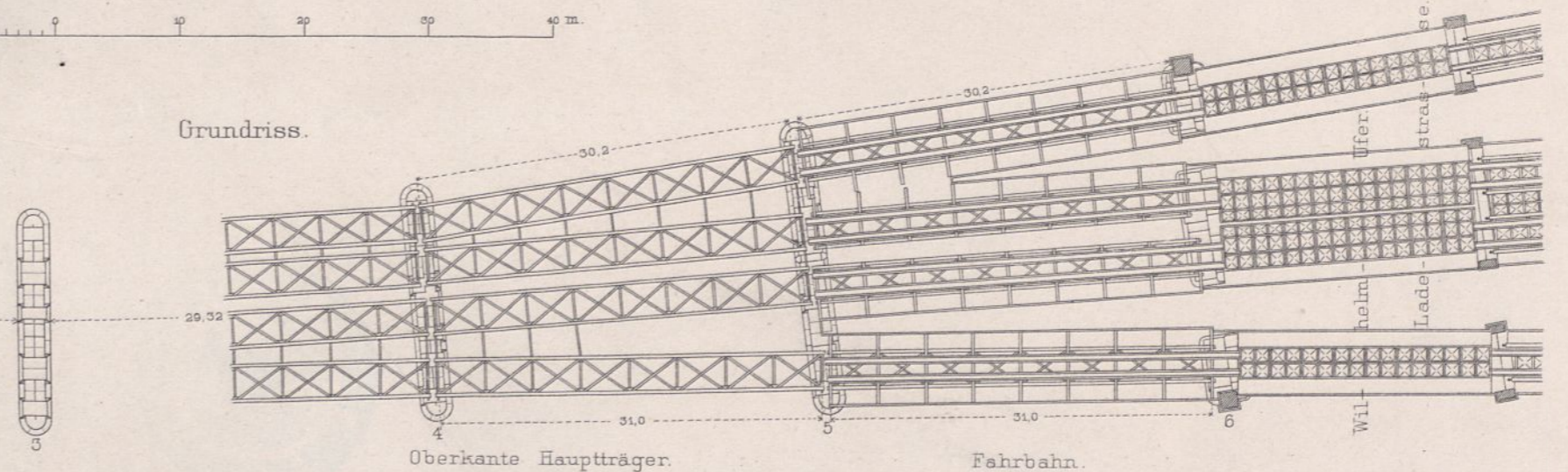

Querschnitte

durch d. Unterführung des Wilhelm-Ufers.

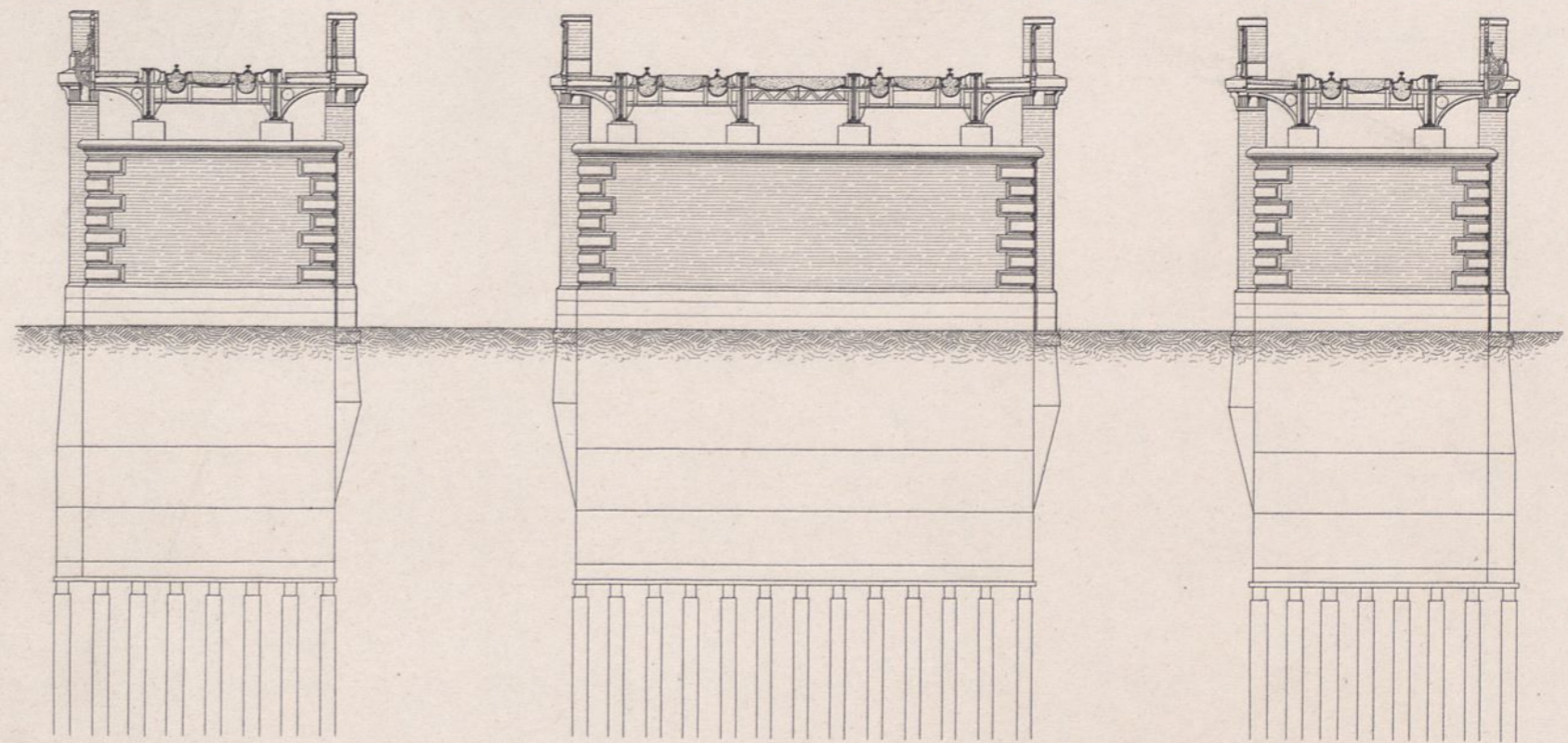
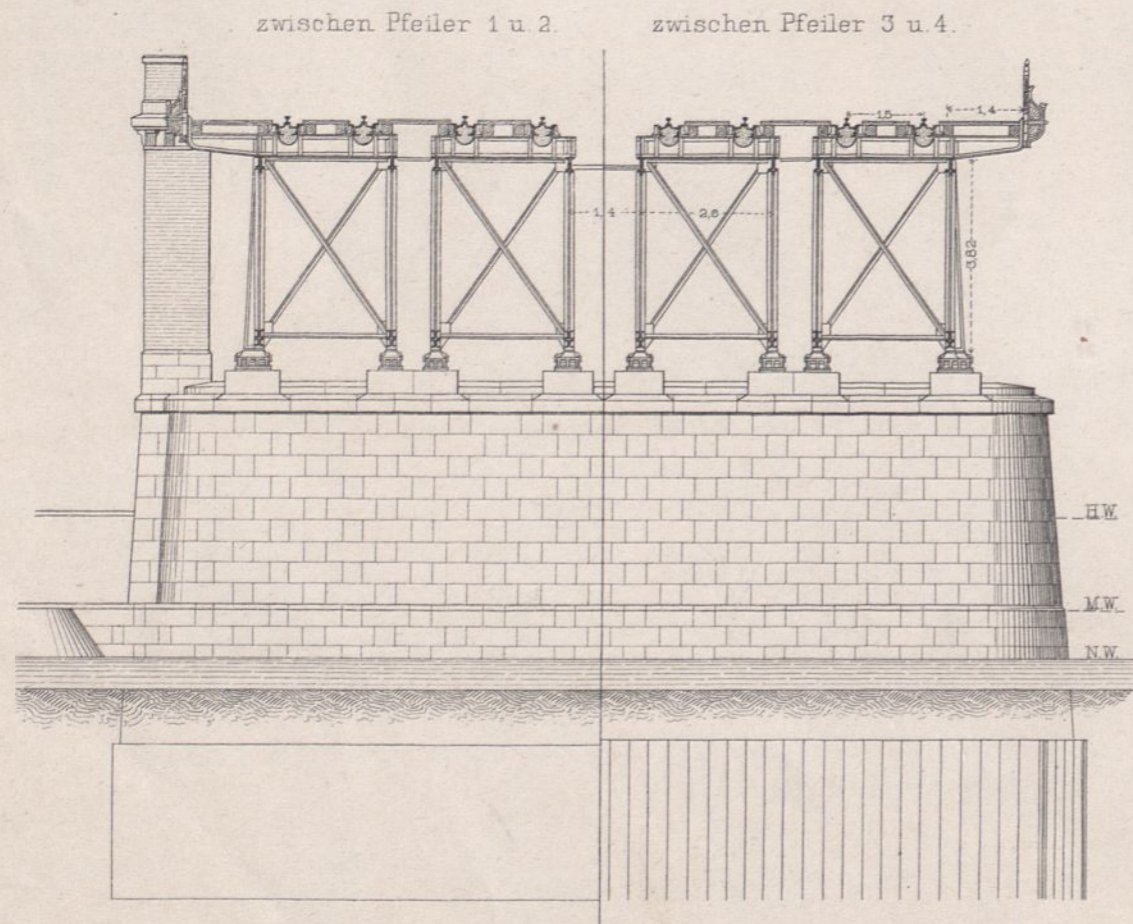

Brücke über den Humboldthafen.

Ansicht eines Hauptträgers.

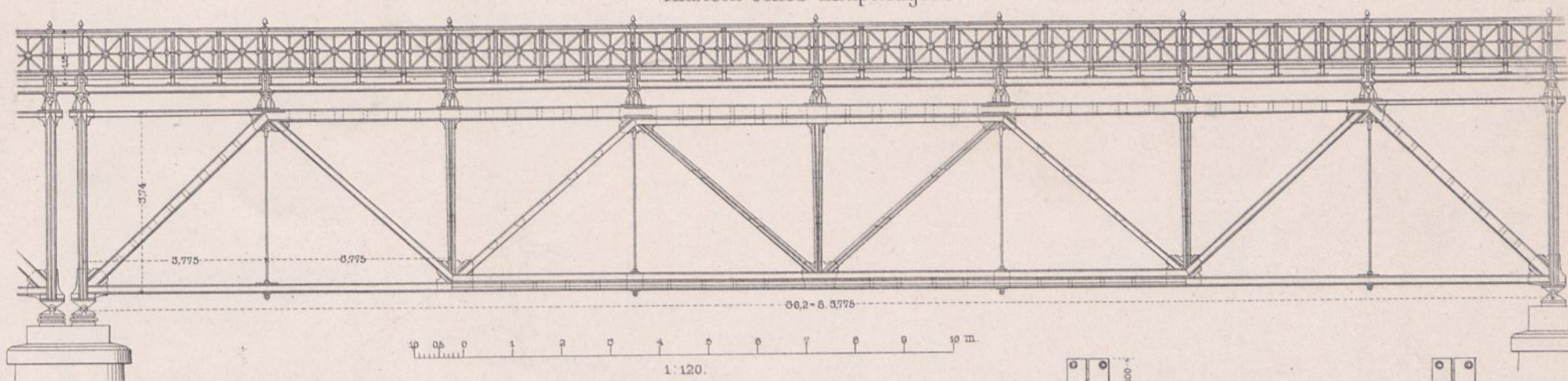

Details der Knotenpunkte.

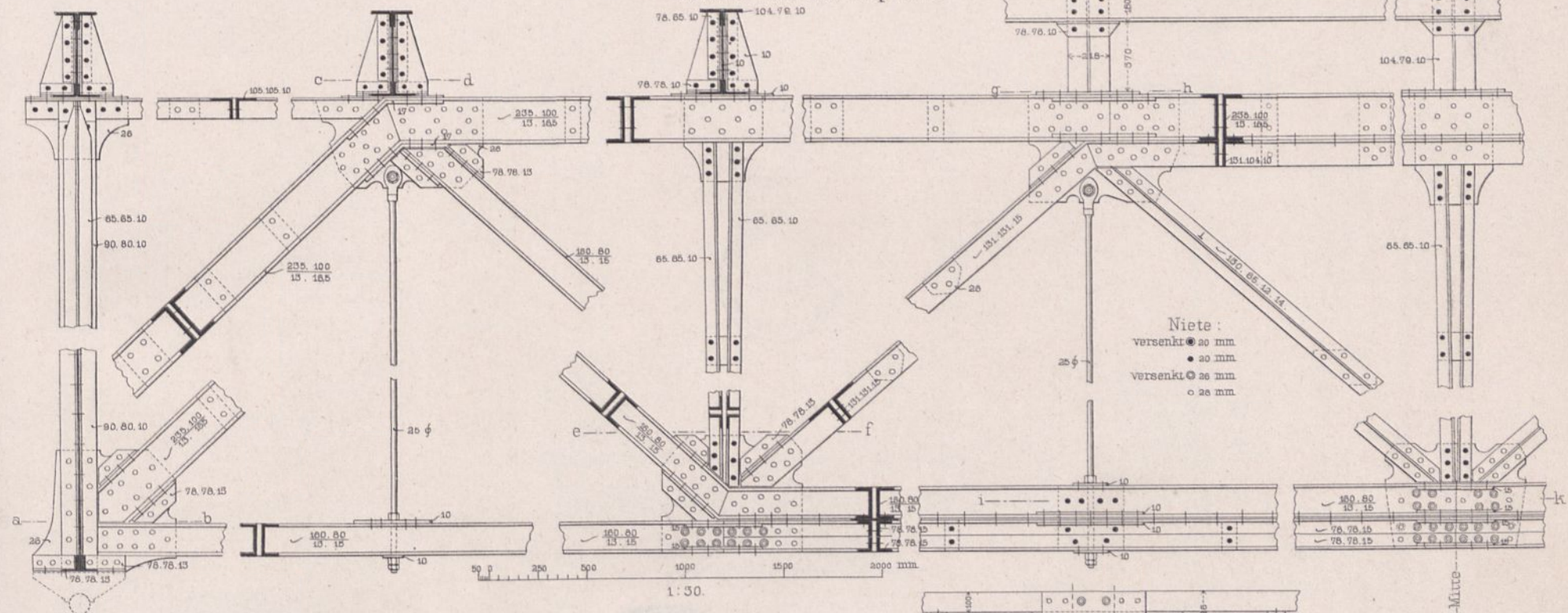

Horizontalschnitte.

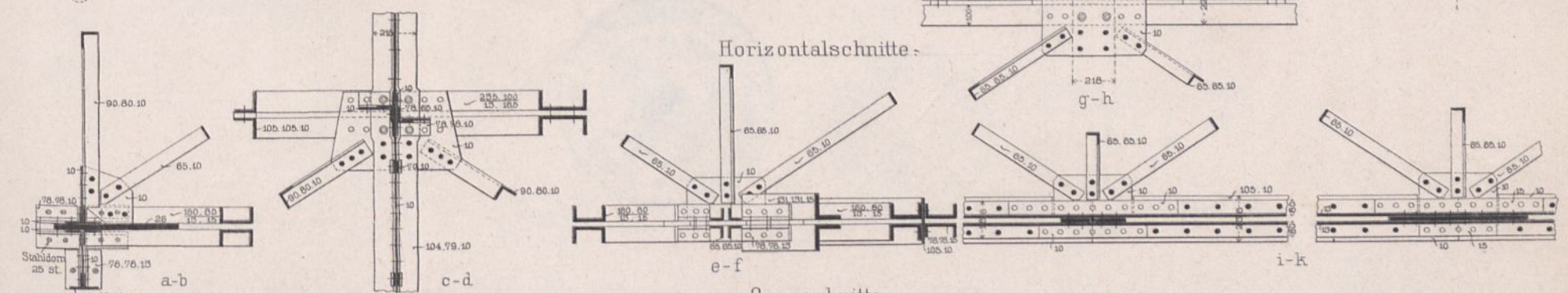

Querschnitte.

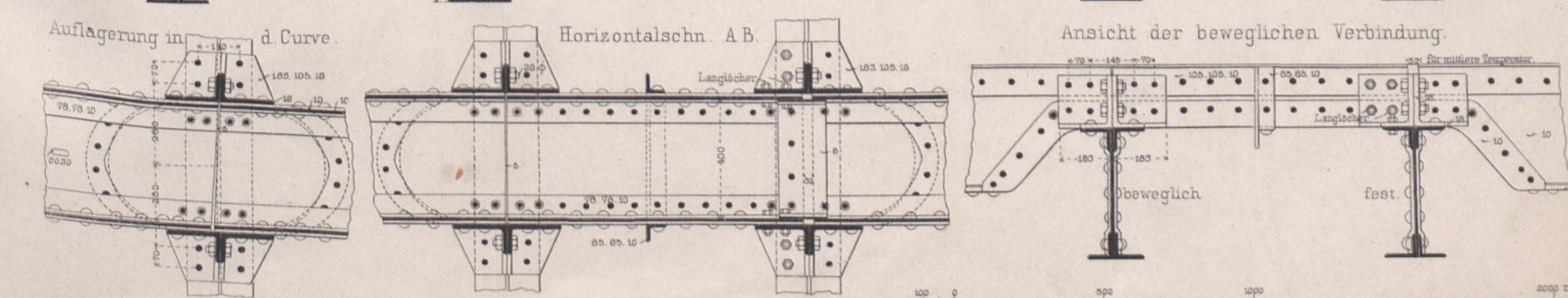
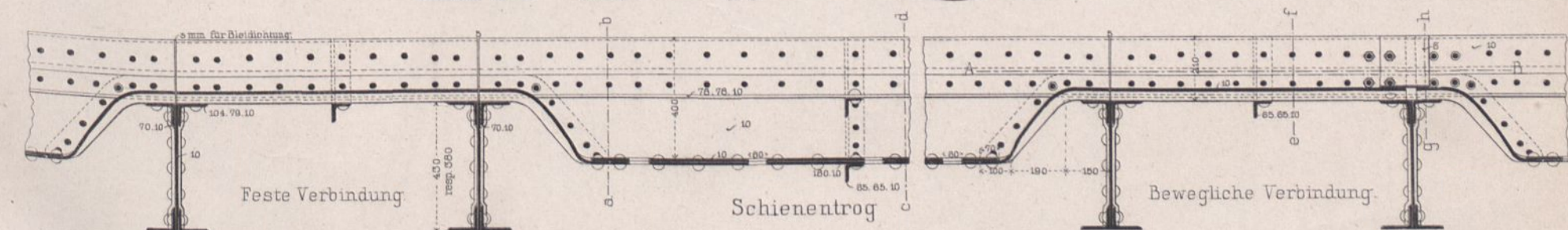
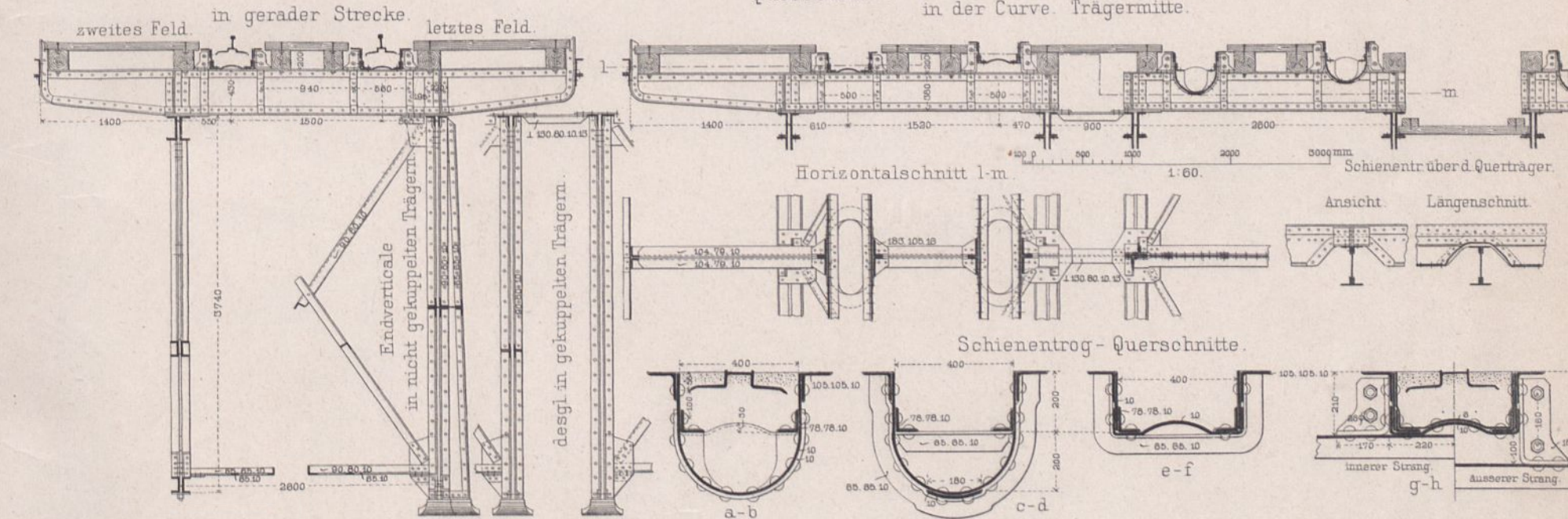

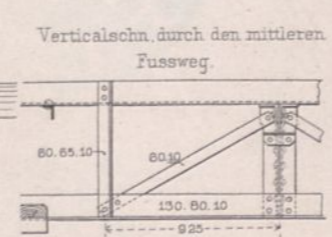
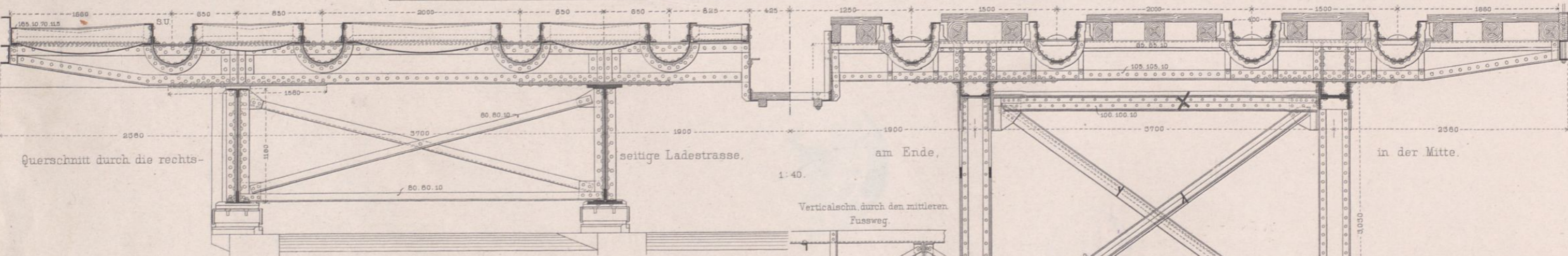
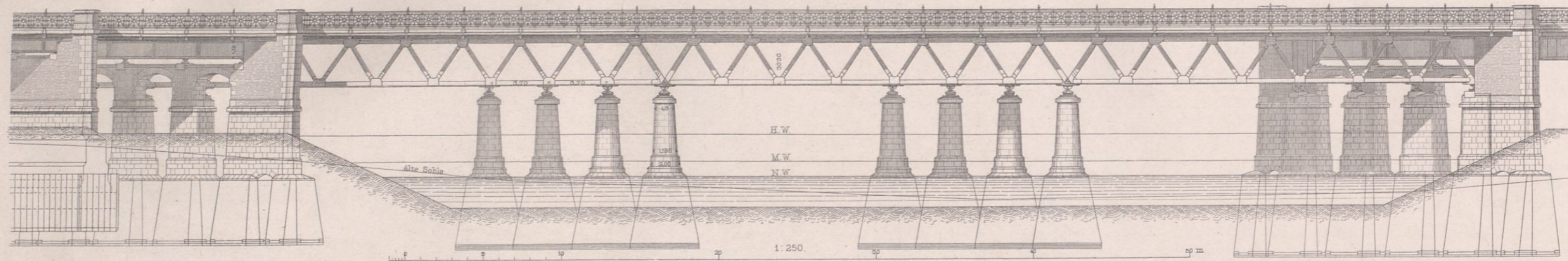

Details des Auflagers auf den Stropfpfeilern.

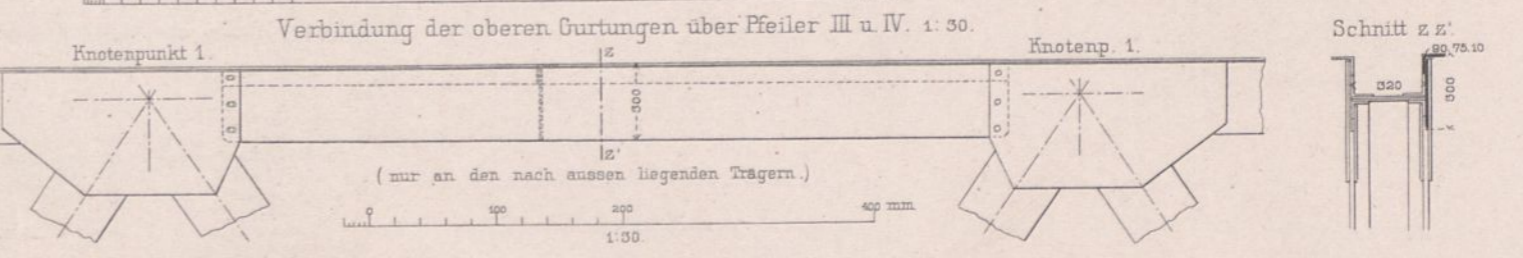
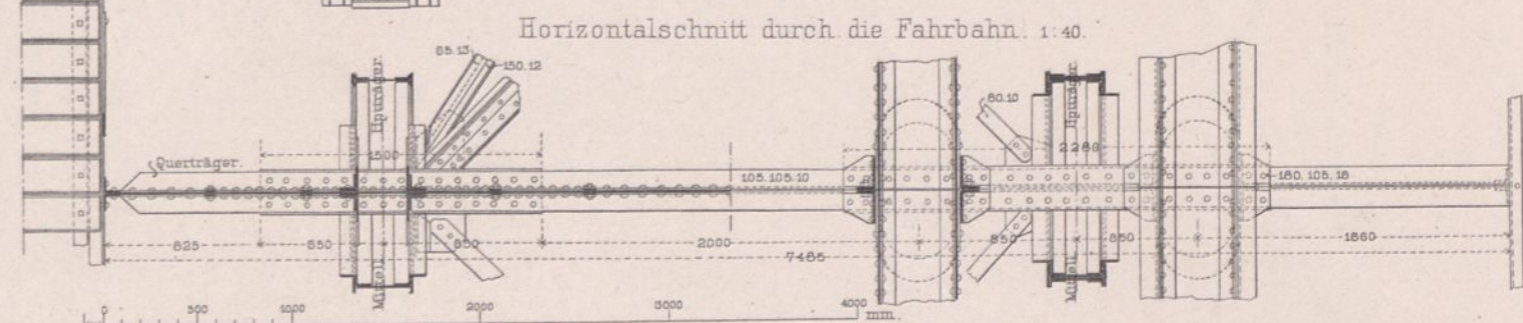
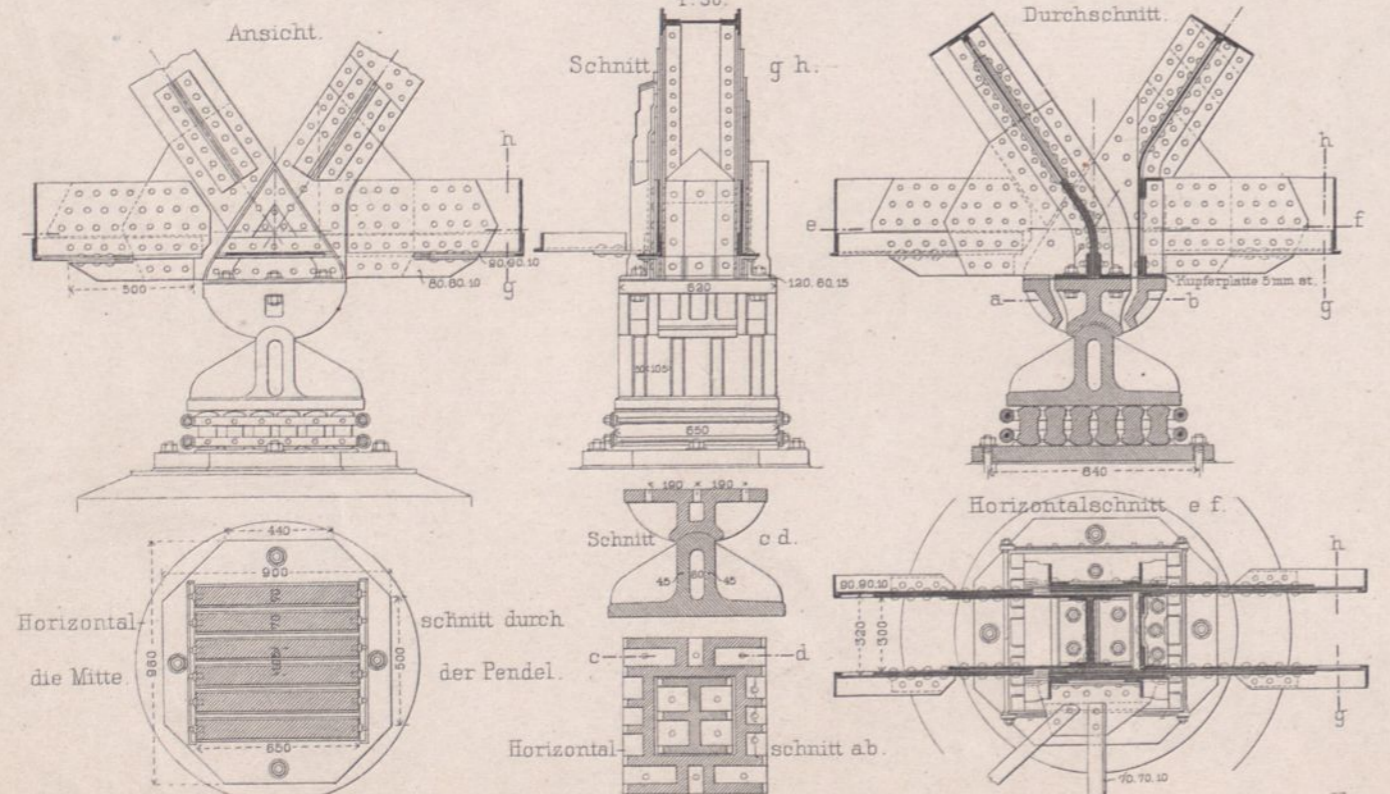

Spreebrücke am Park Bellevue

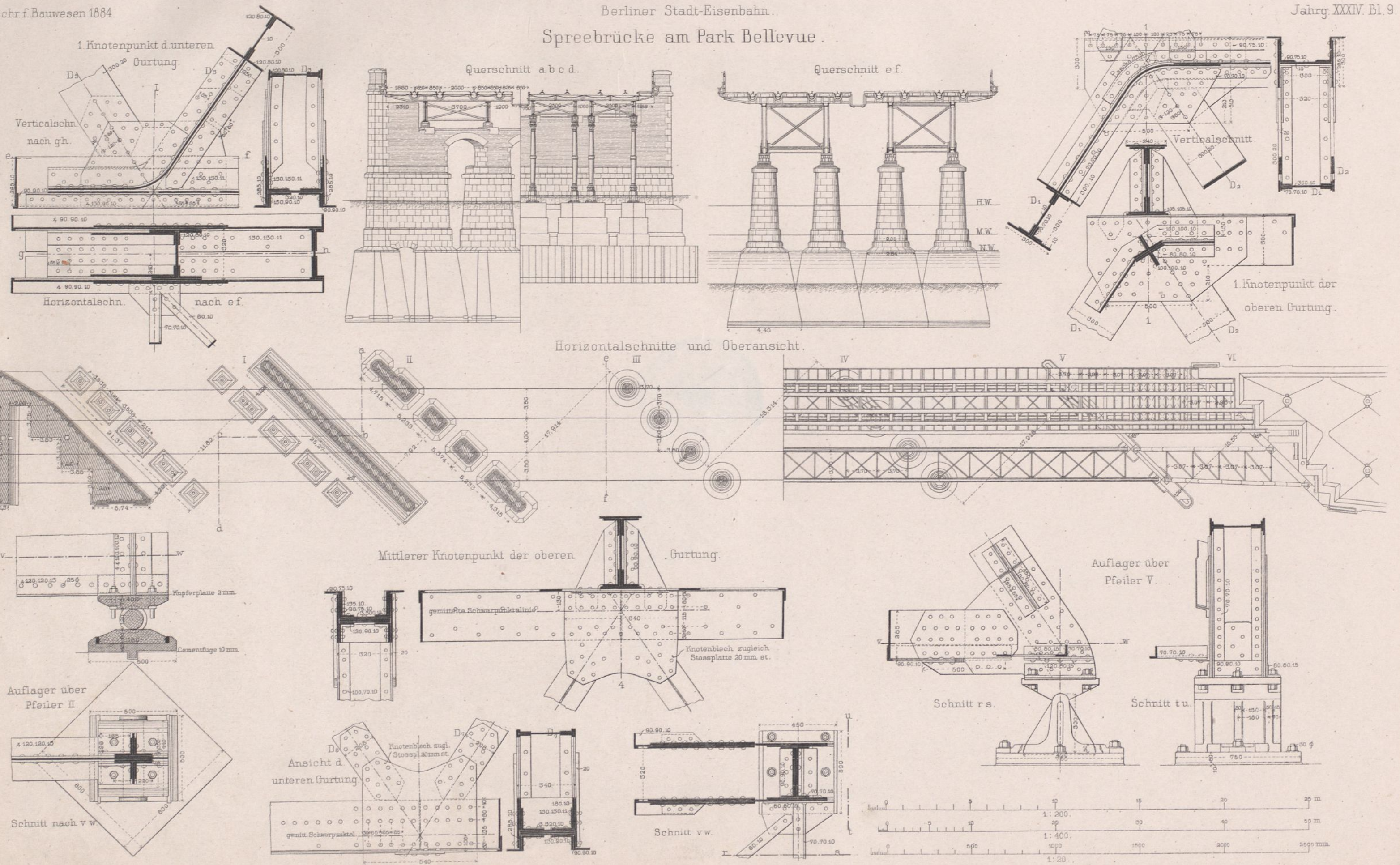

Unterführung des Kupfergrabens und der Strasse am Kupfergraben.

1 Ansicht

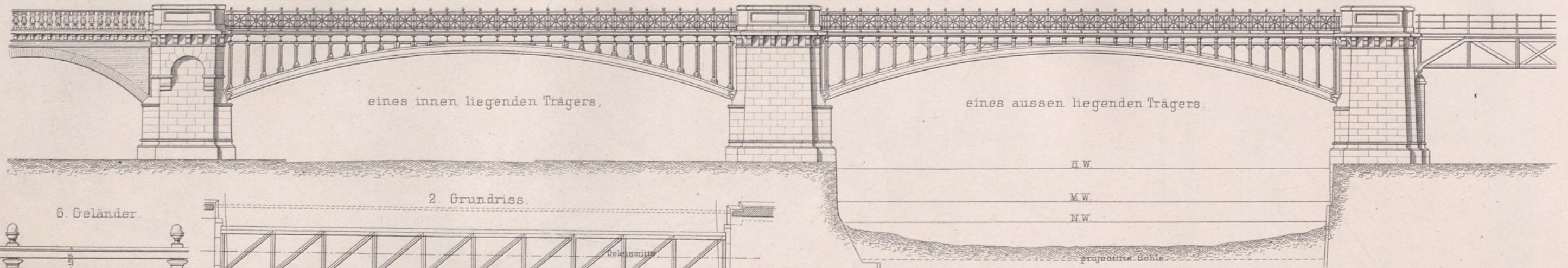

2 Grundriss

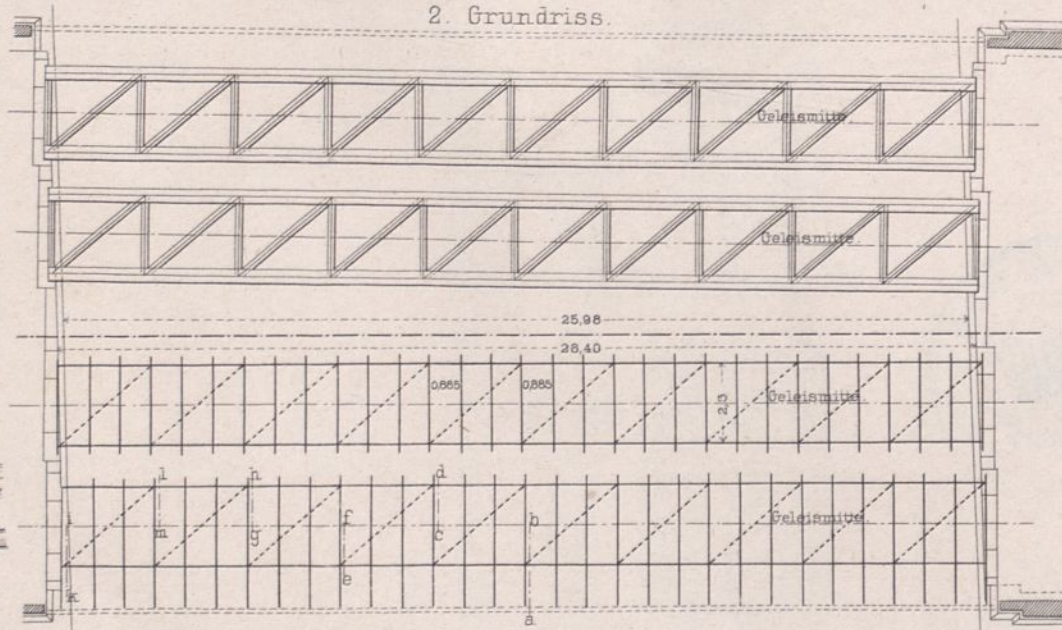

6 Geländer

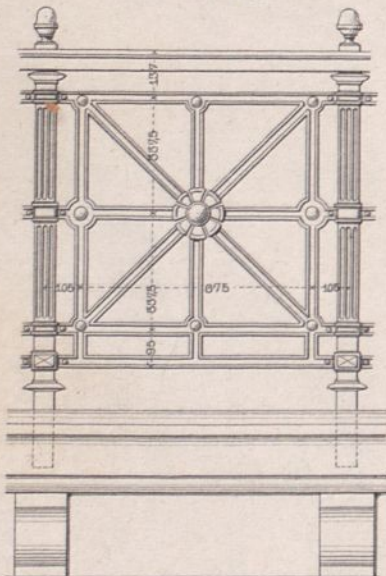

4 Schnitt a b

5 Schnitt c d

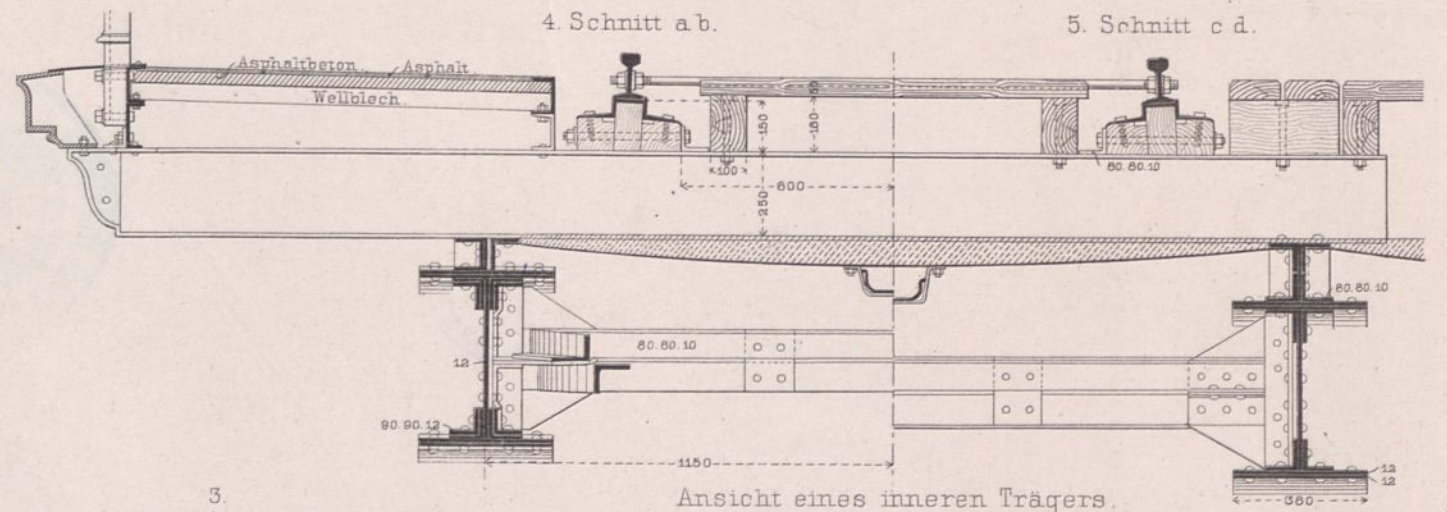

Ansicht eines äusseren Trägers

Ansicht eines inneren Trägers

Schnitt i k

Schnitt l m

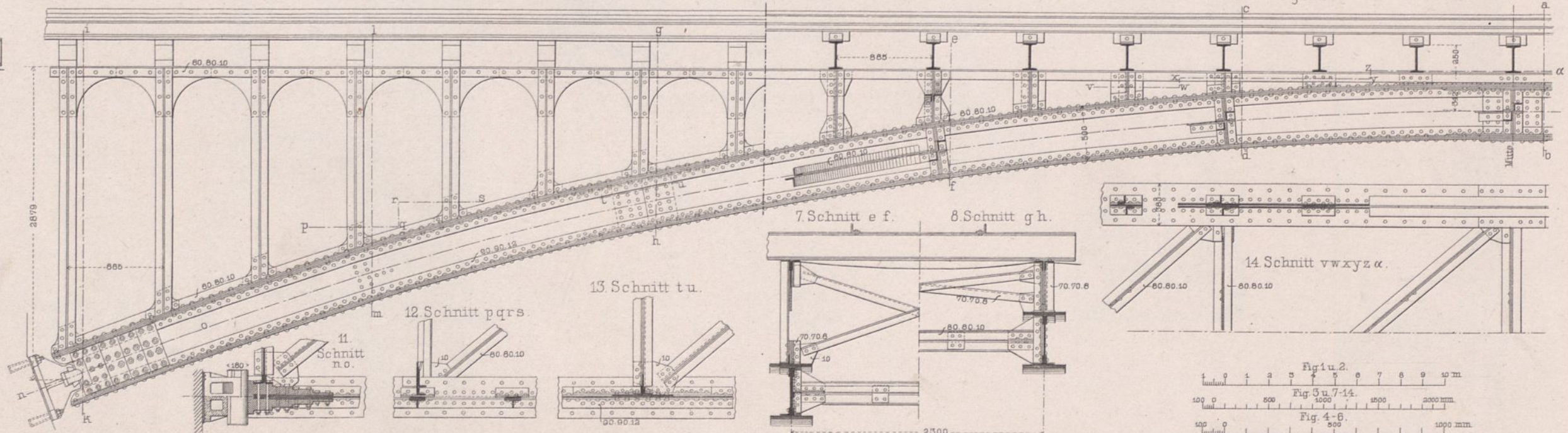
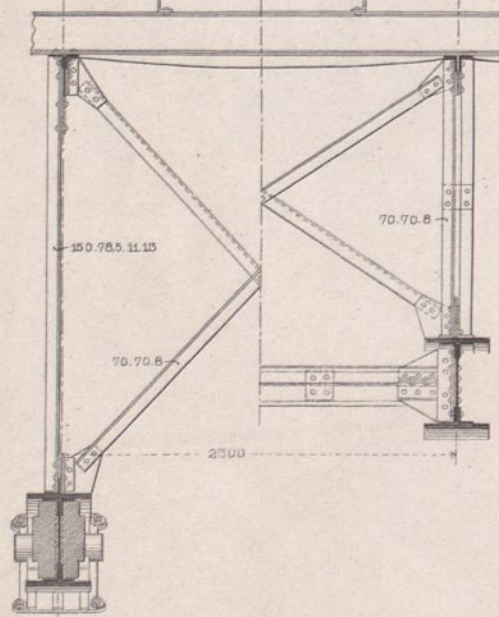

13 Schnitt t u

12 Schnitt p q r s

11 Schnitt n o

7 Schnitt e f

8 Schnitt g h

14 Schnitt v w x y z α

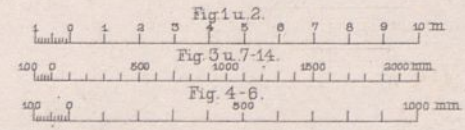

Unterführung der Königstrasse.

1. Ansicht.

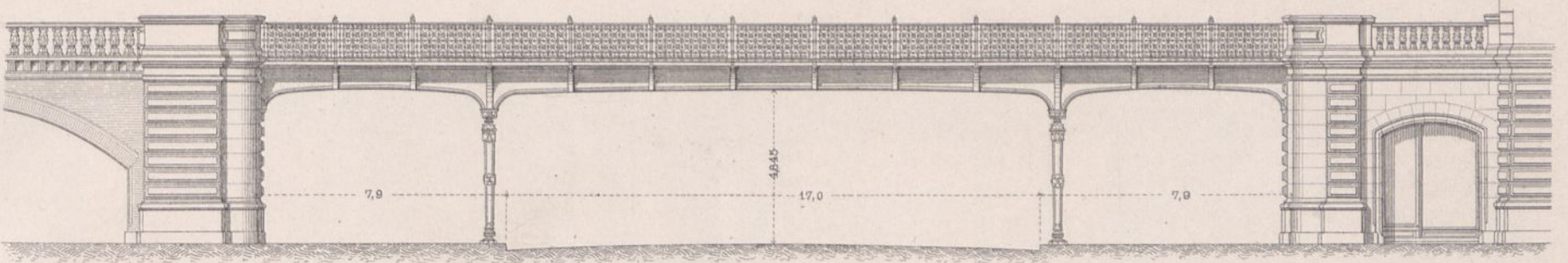

4-4c. Säule.
4. Vorderansicht.

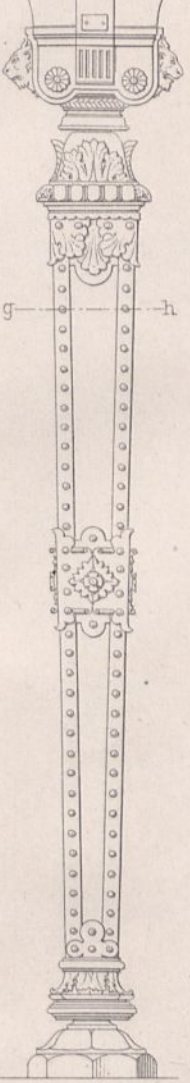

2. Querschnitt u. Ansicht des östlichen Widerlagers.

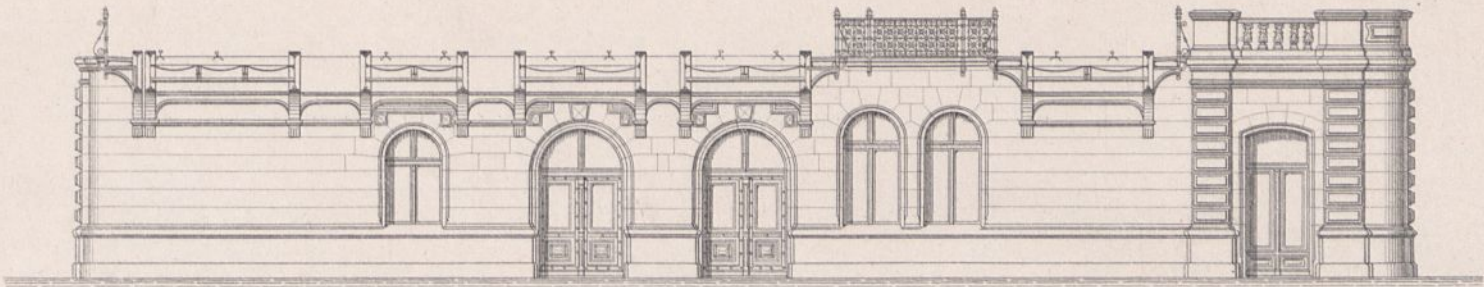

Seiten-4^a Schnitt
ansicht. ab.

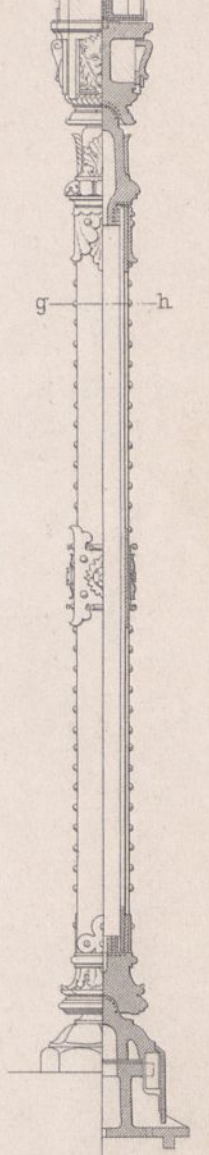

3. Grundriss.

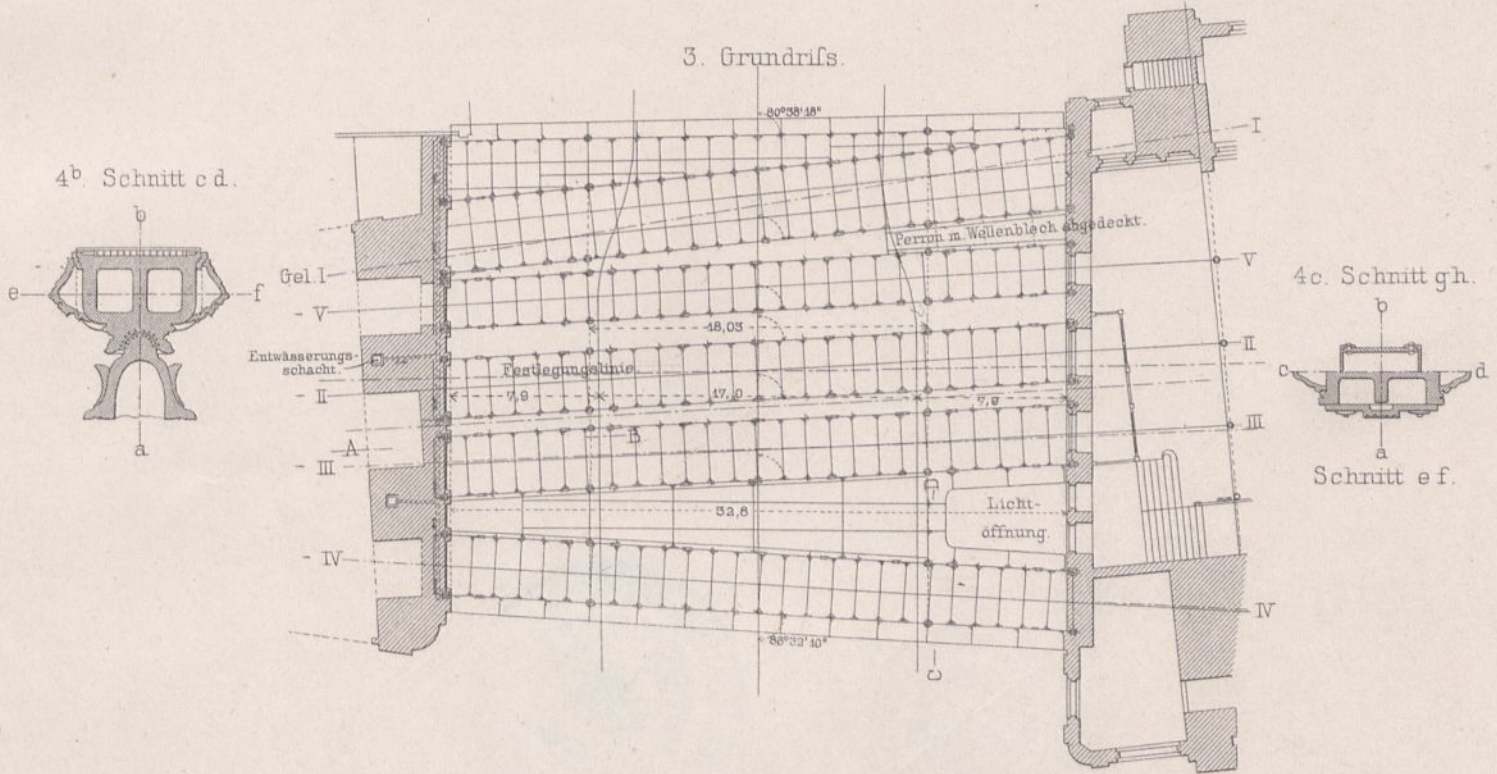

4^b Schnitt c d.

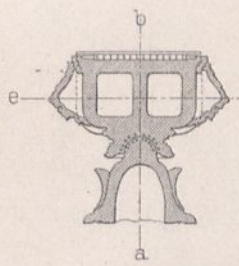

4c. Schnitt gh.

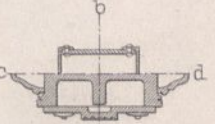

Schnitt ef.

5. Längenschnitt der Hauptträger nach AB.

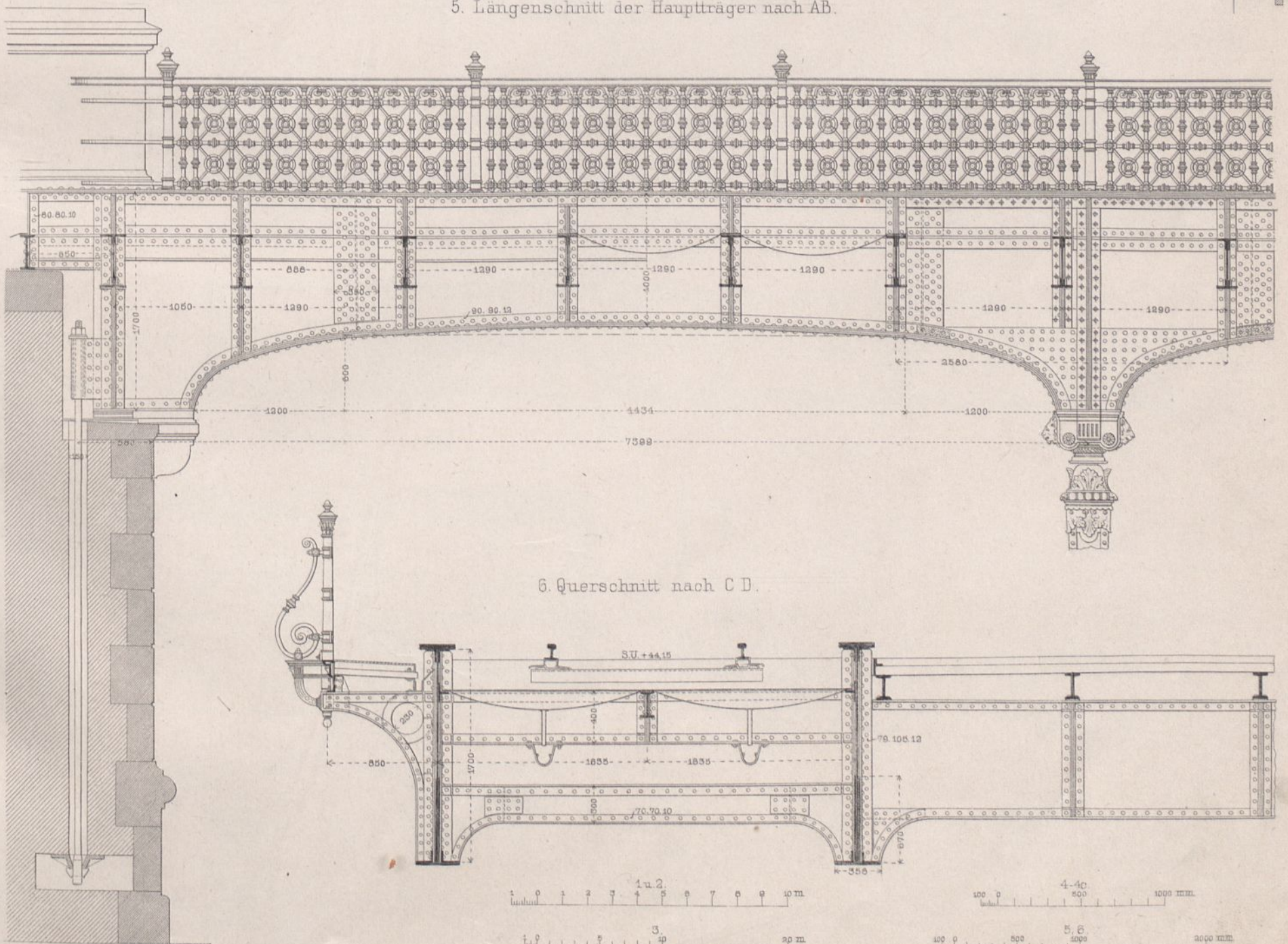

6. Querschnitt nach C D.

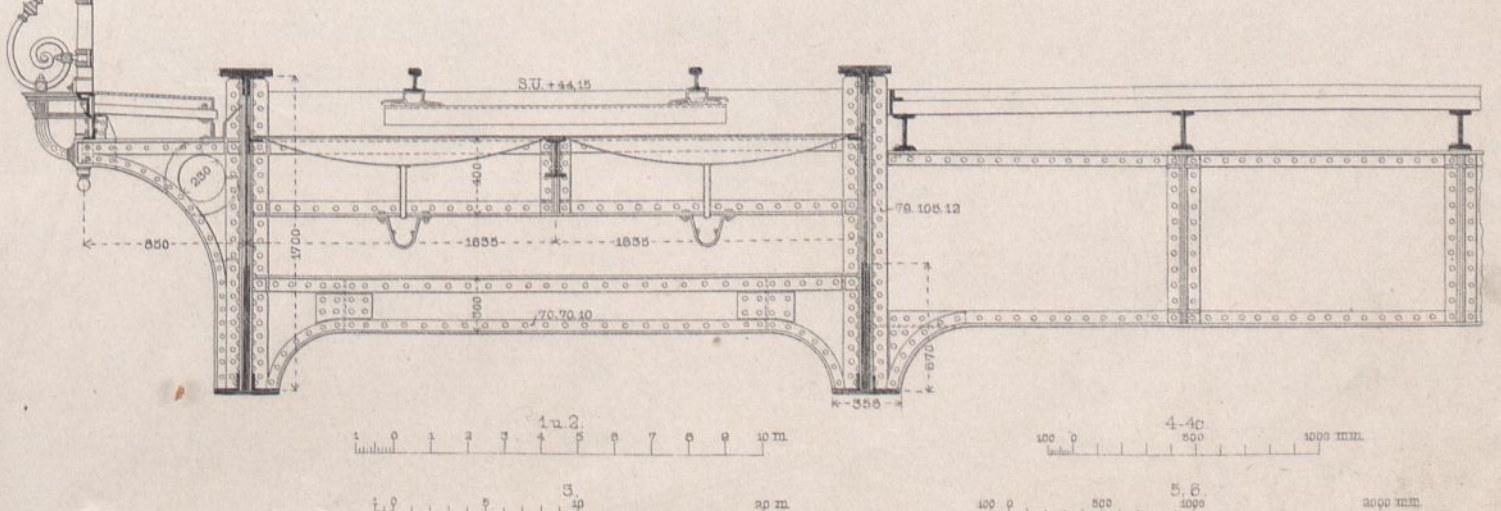

Unterführung der Strasse Alt-Moabit.

1. Nordwestliche Ansicht.

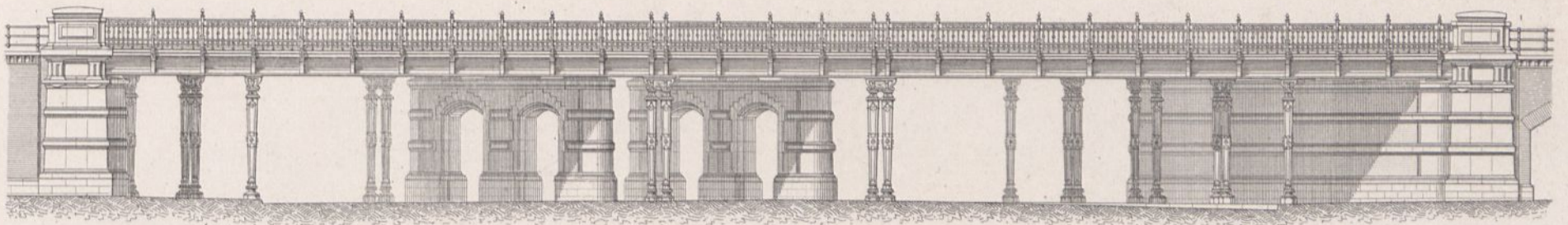

2 Grundriss der Eisenconstruction.

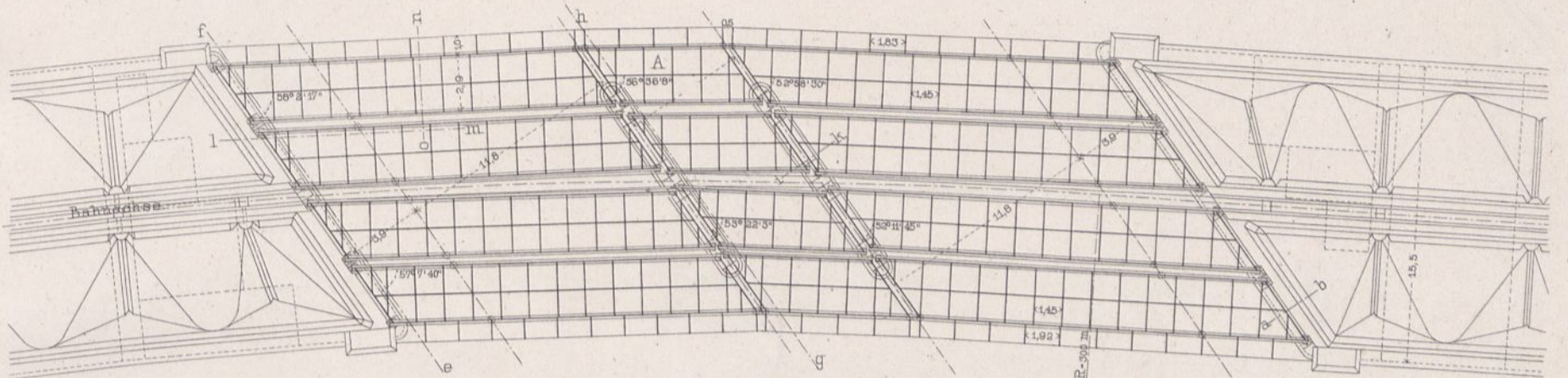

3 Schnitt ab.

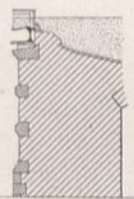

4 Schnitt e f.

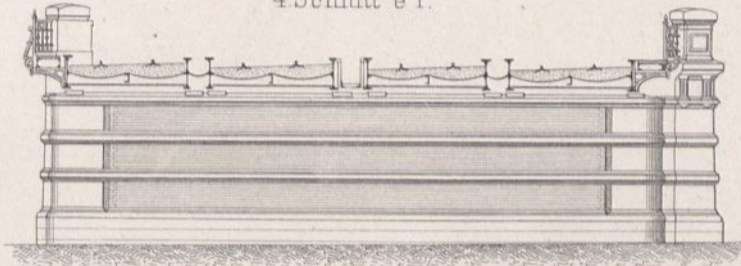

5 Schnitt g h.

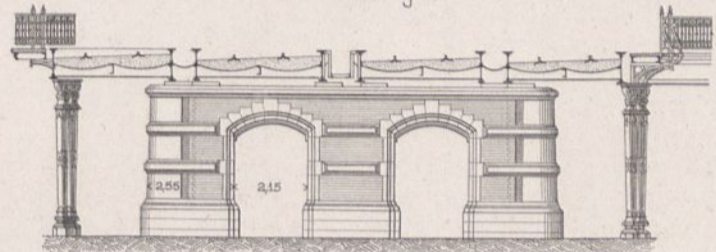

6 Schnitt i k.

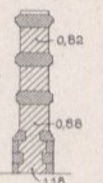

7 Grundriss des Ueberbaues bei A.

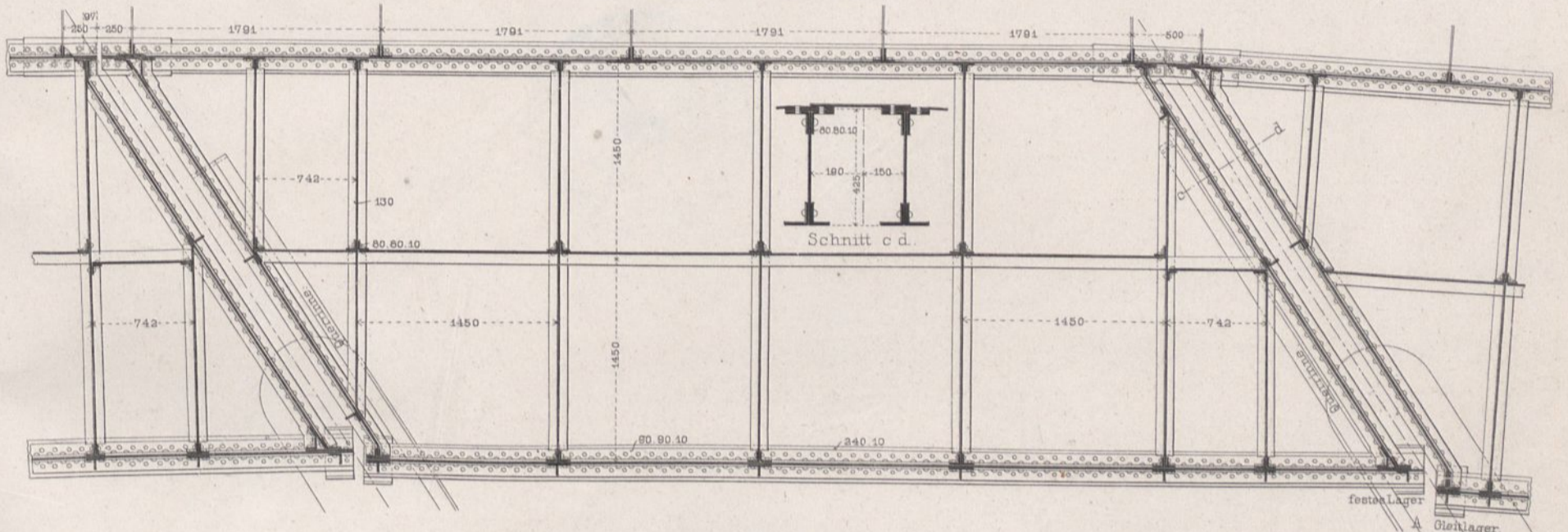

8 Schnitt l m.

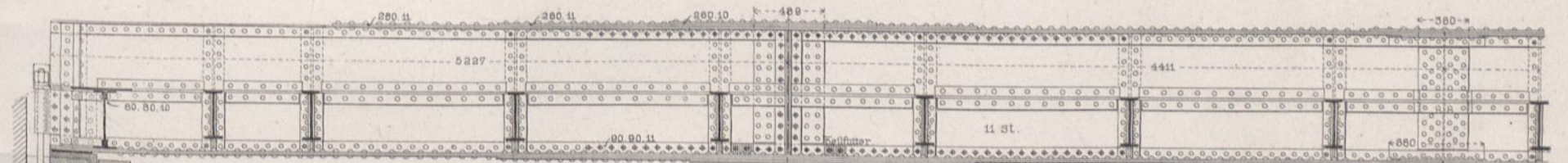

9 Geländer-Ansicht.

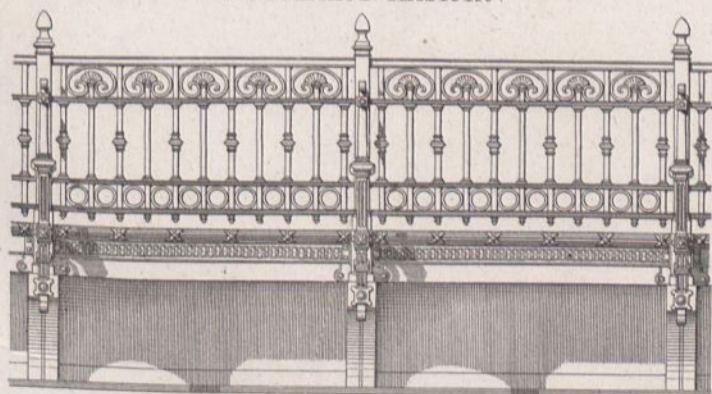

10 Schnitt n o.

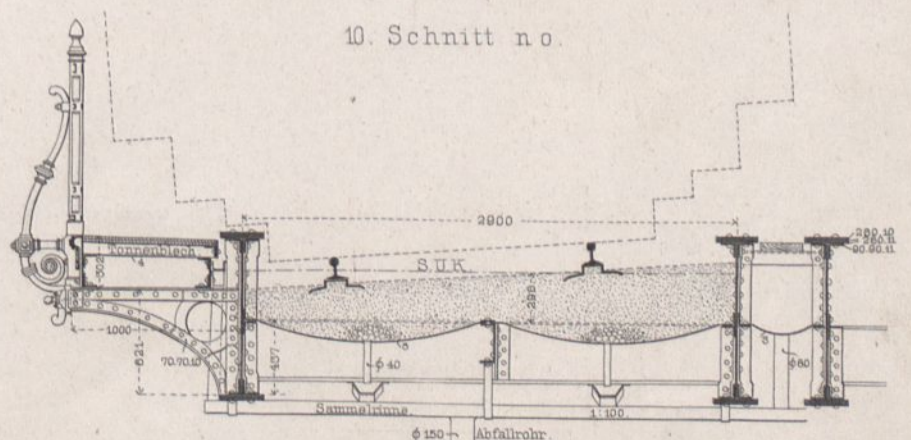

11. Details der schmiede-eisernen Säulen.

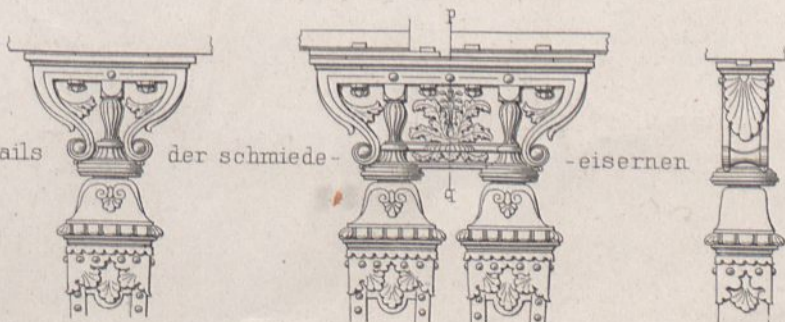

Säulen.

Schnitt p q.

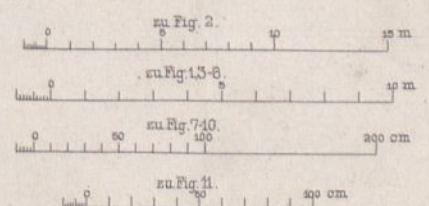

Unterführung der Kleinen Präsidentenstrasse.

1. Ansicht nach a b c d.

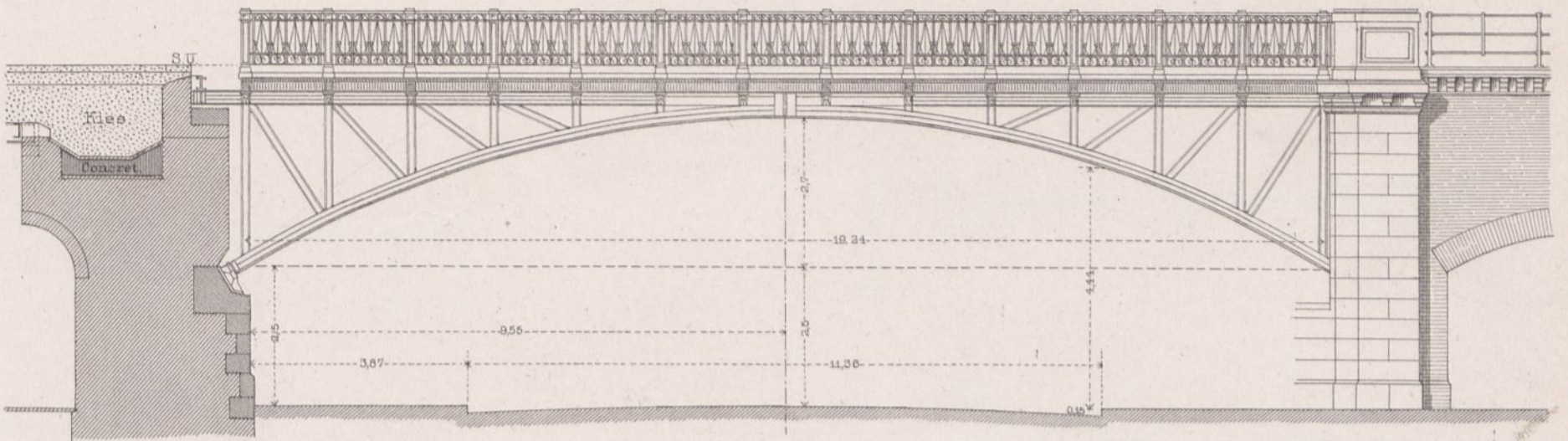

2. Grundriss des Geleises IV.

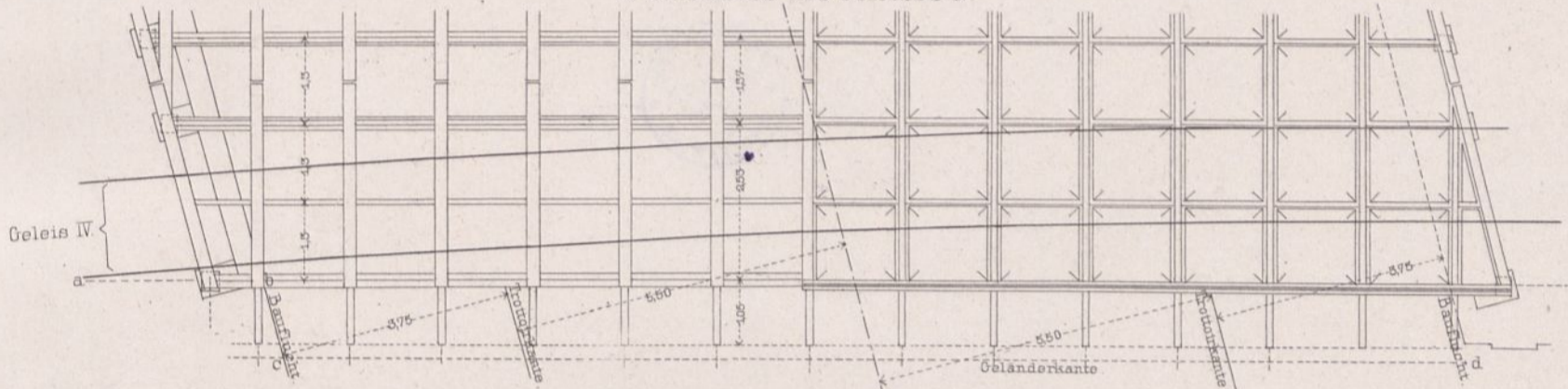

3. Ansicht

eines inneren Trägers.

eines äusseren Trägers.

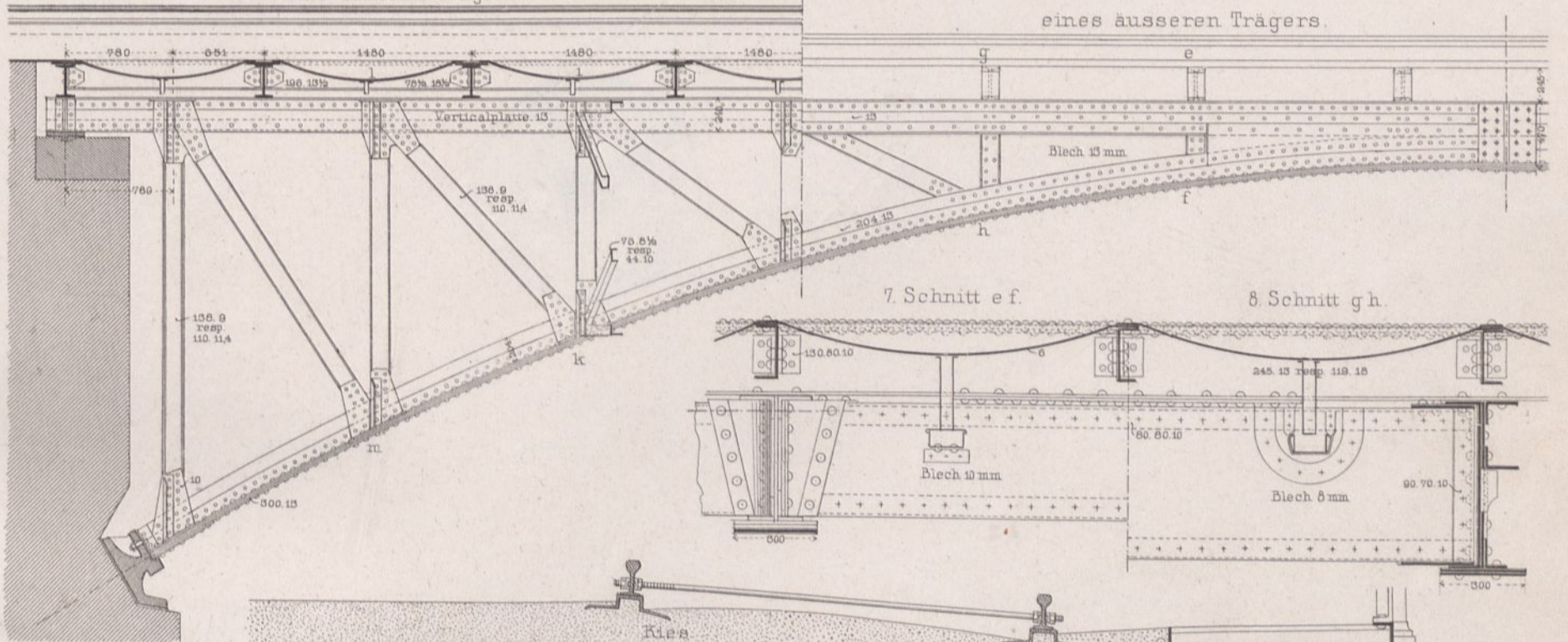

7. Schnitt e f.

8. Schnitt g h.

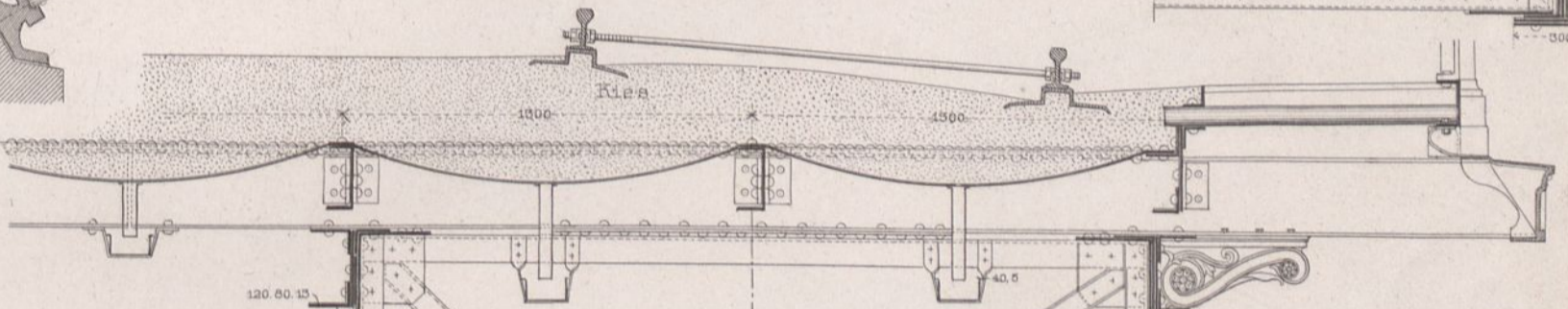

4. Schnitt r s.

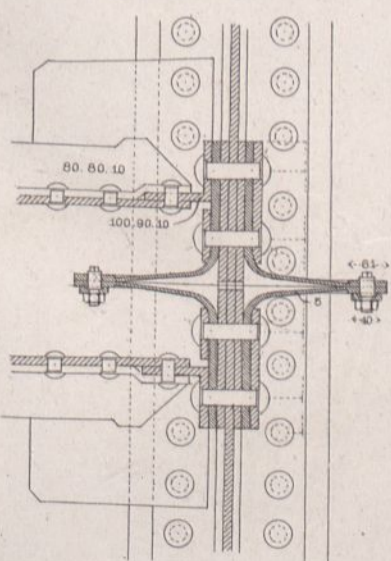

5. Schnitt l m.

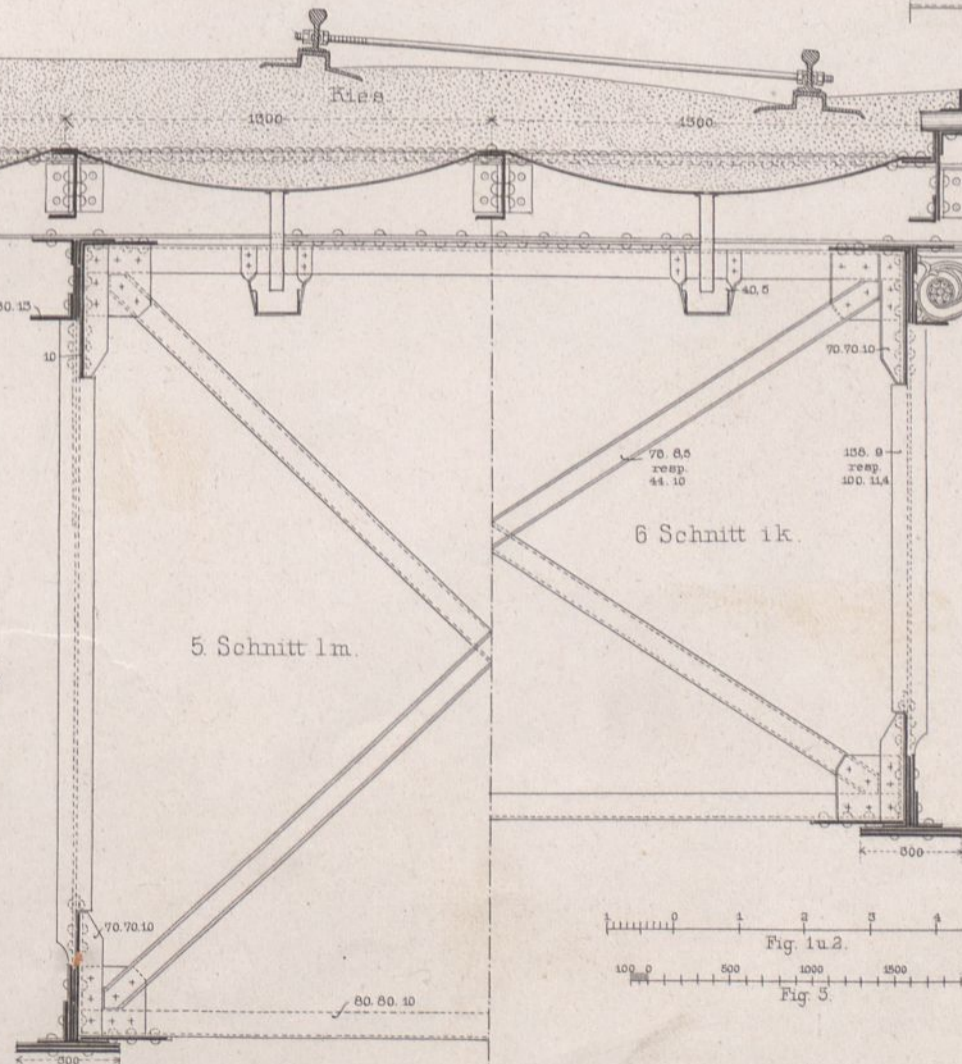

6. Schnitt i k.

9. Situation.

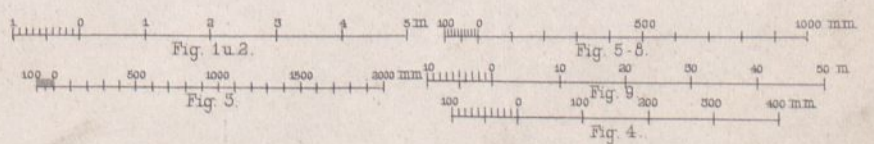
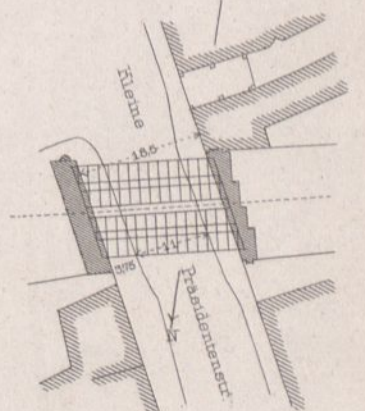

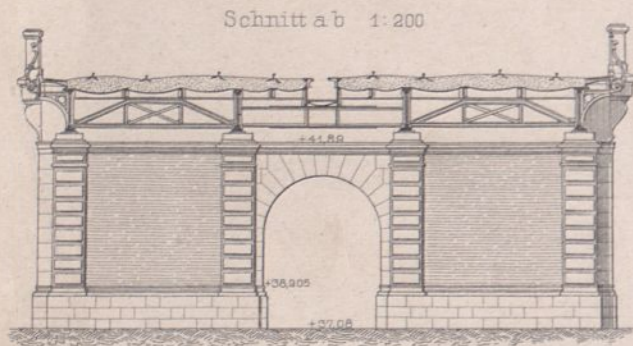
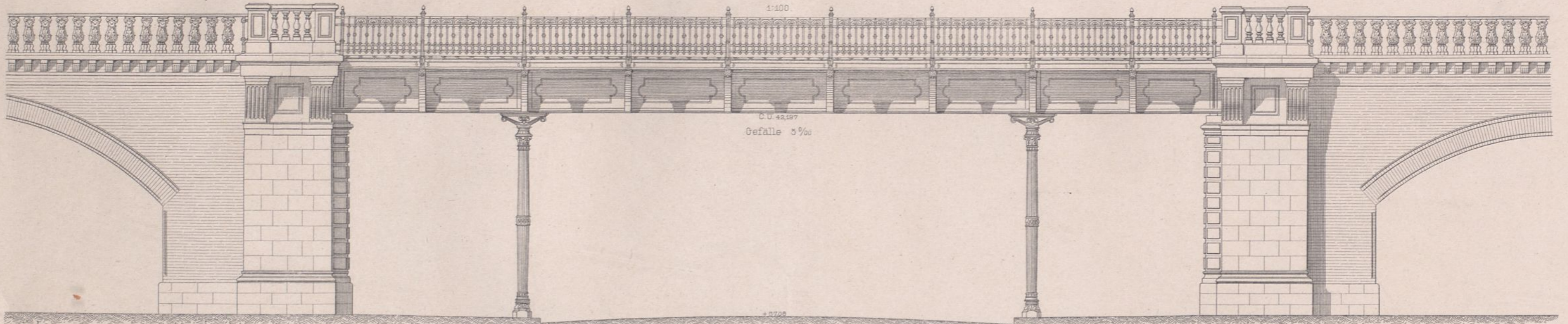

Schnitt a b 1:200

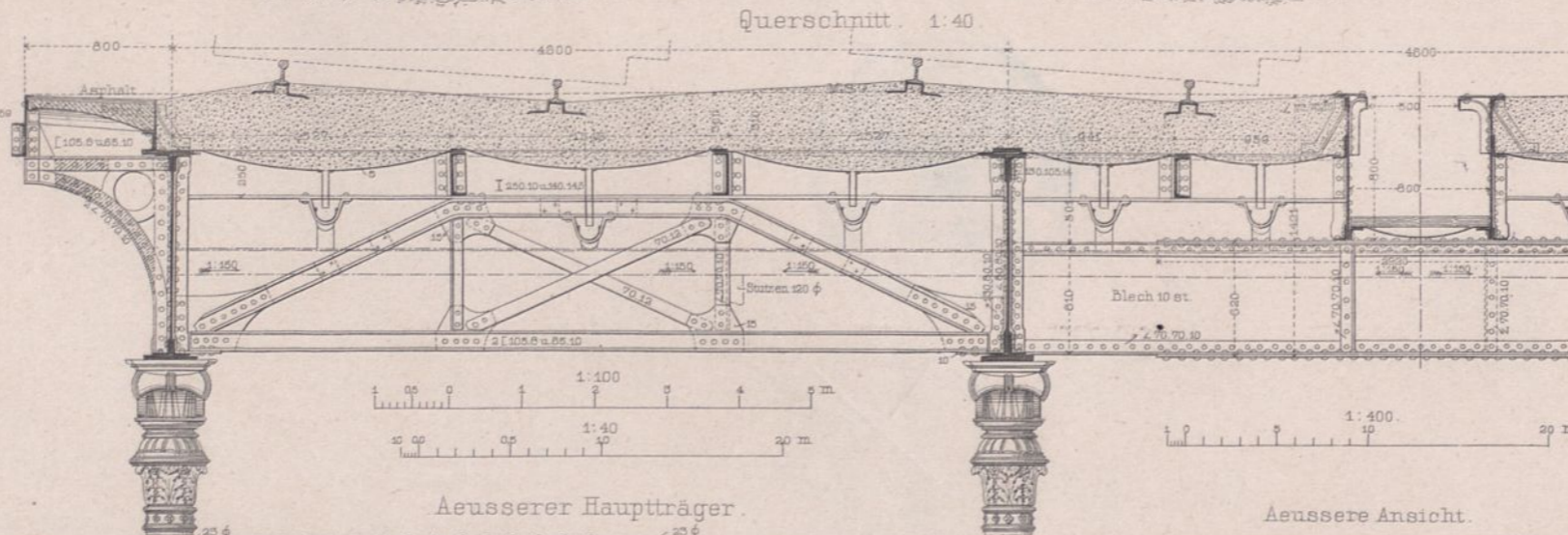

Querschnitt 1:40

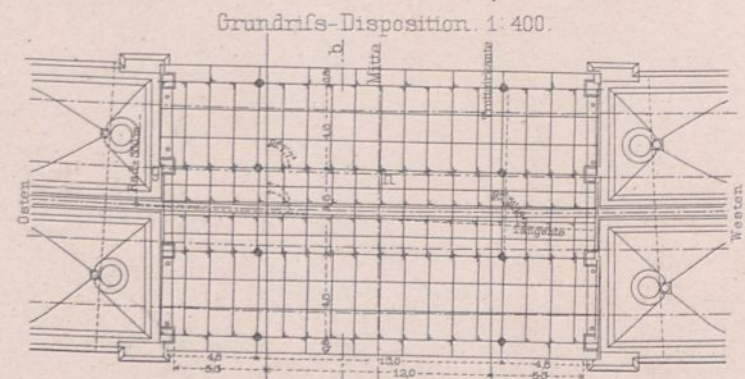

Grundriffs-Disposition 1:400

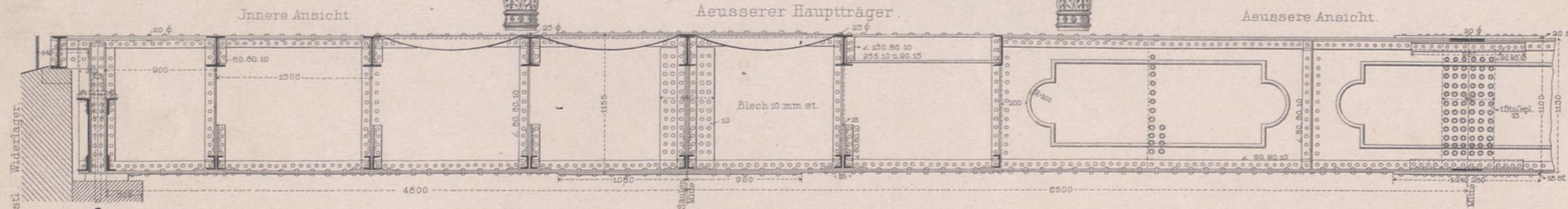

Innere Ansicht

Aeusserer Hauptträger

Aeusserer Ansicht

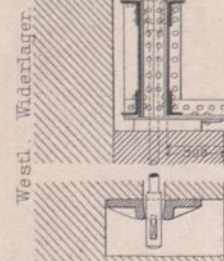

Westl. Widerlager

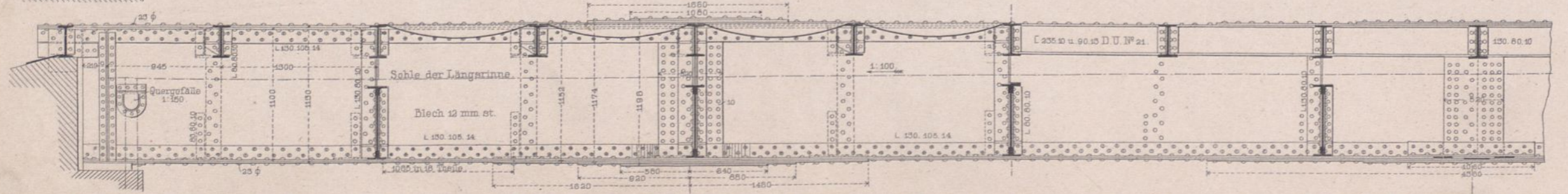

Innere Ansicht des inneren Hauptträgers

Schnitt g h

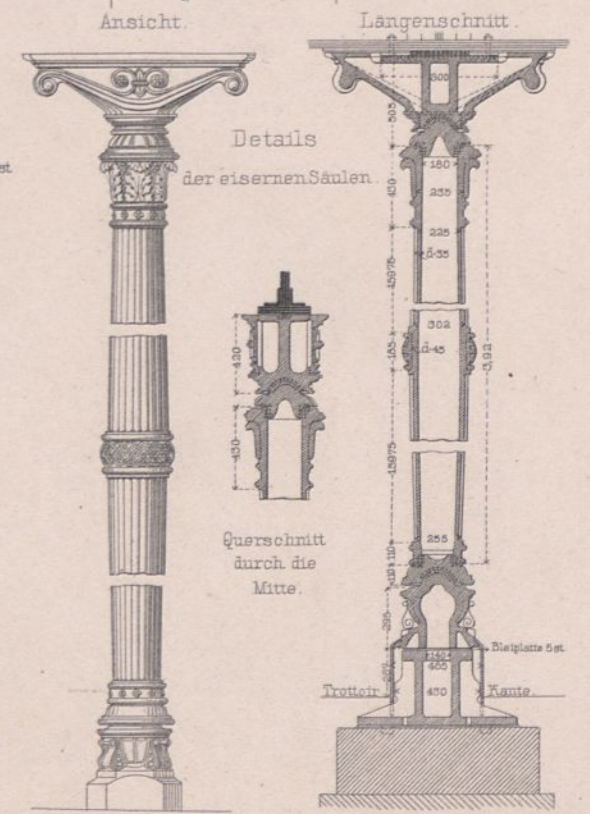

Ansicht

Langenschnitt

Details der eisernen Säulen

Querschnitt durch die Mitte

Unterführung der Stallstrasse.

1. Ansicht.

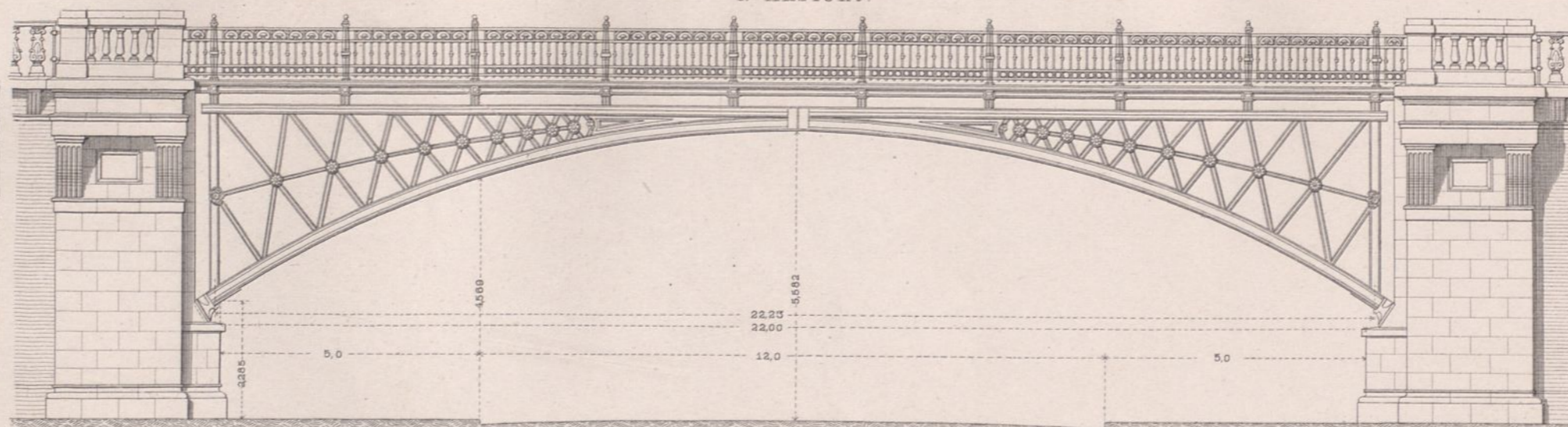

2 Grundriss des Geleises I.

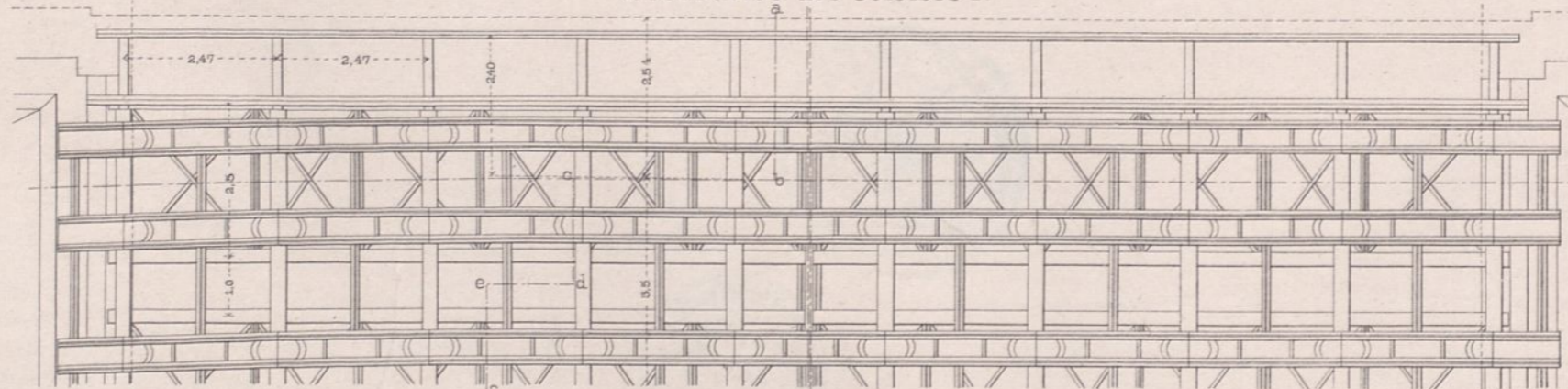

3 Längenschnitt vor einem inneren Träger.

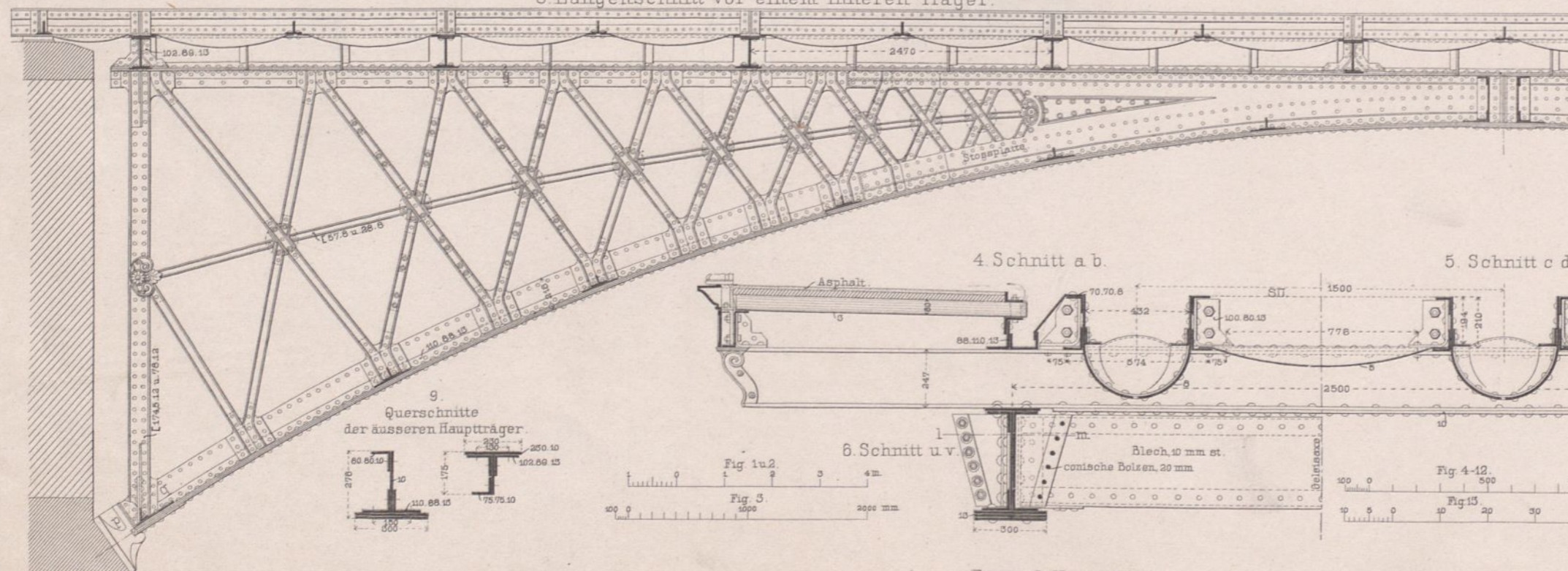

4 Schnitt a b.

5 Schnitt c d.

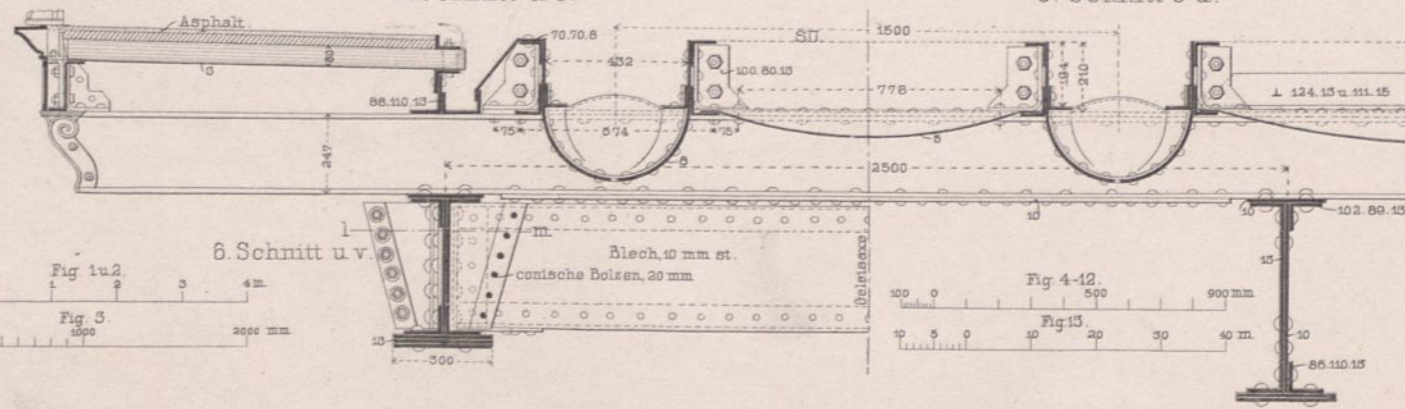

9 Querschnitte der äusseren Hauptträger.

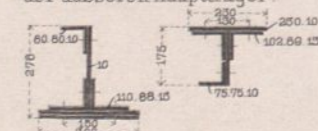

6 Schnitt u v.

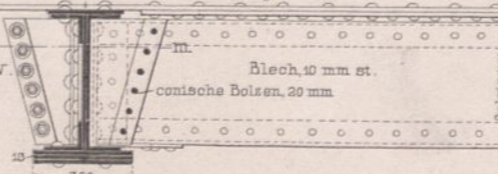

7 Schnitt l m.

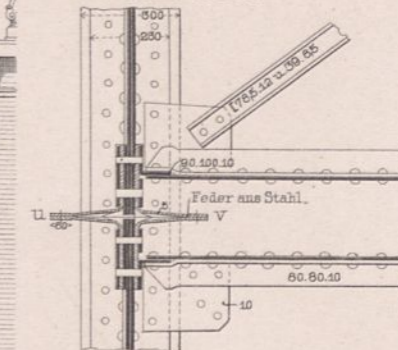

8 Ansicht auf d. Feder.

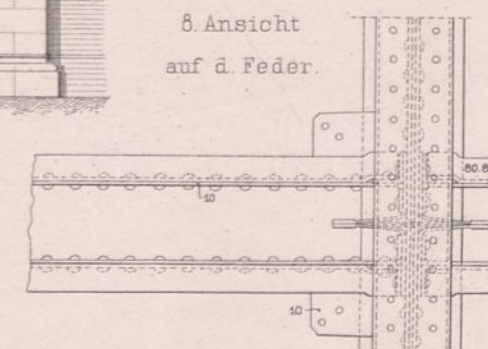

9 Schnitt e f.

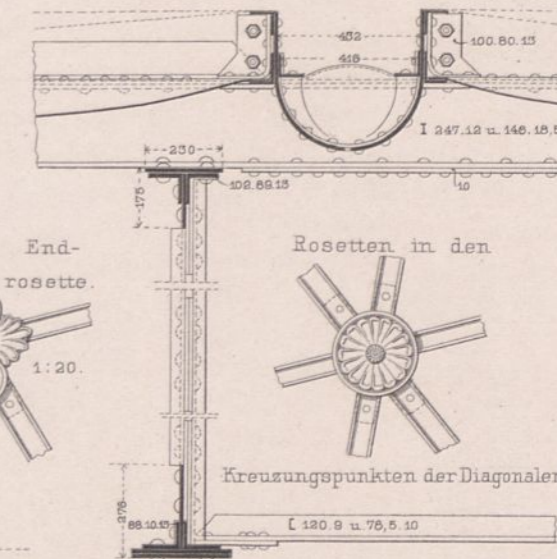

Endrossette.

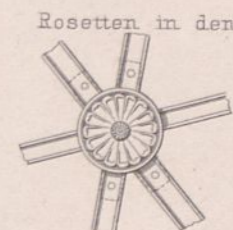
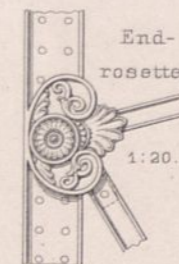

13. Situation

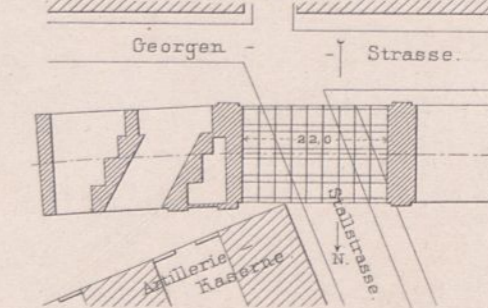

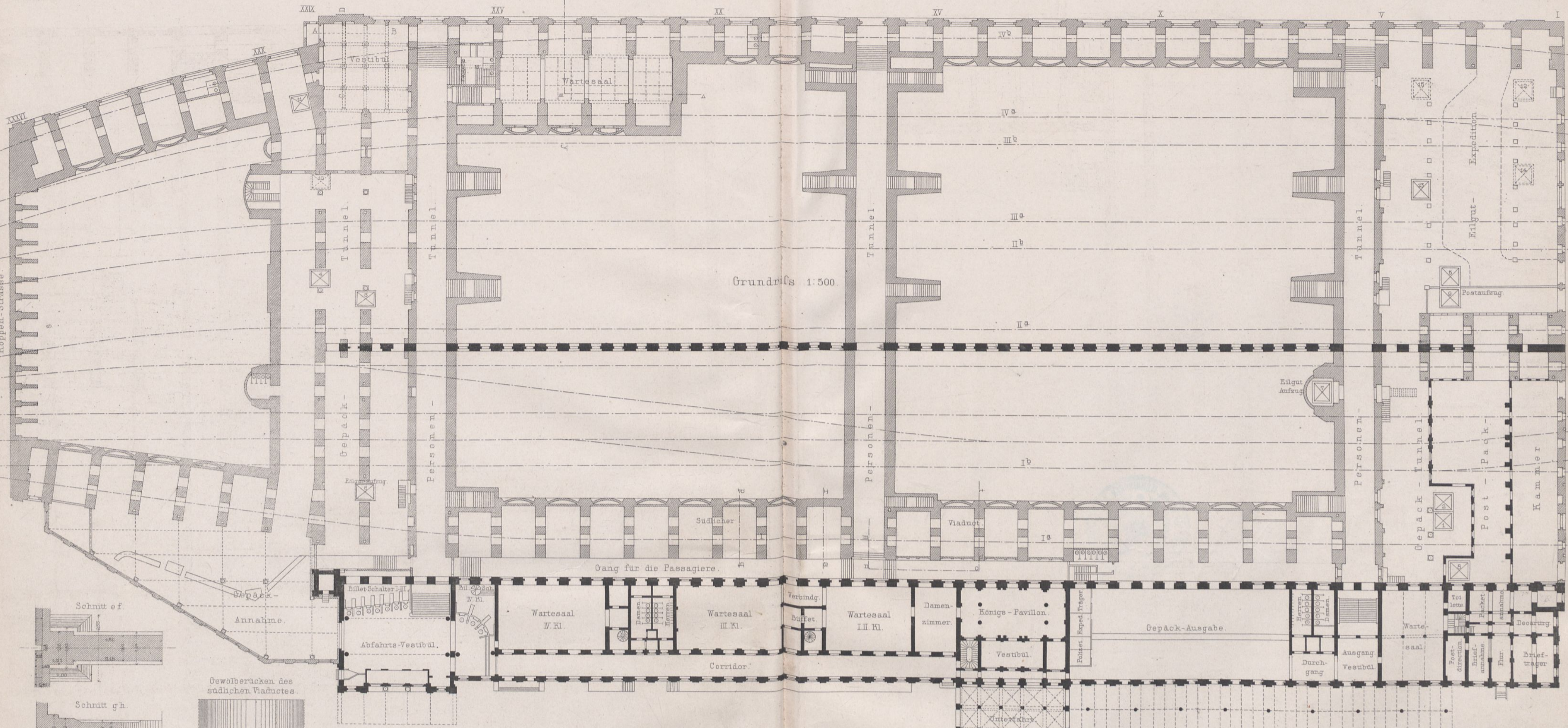

Grundriss 1:500.

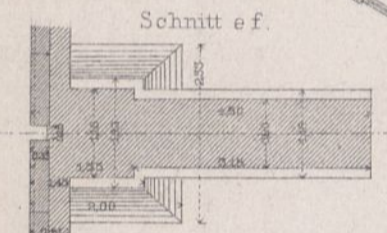

Schnitt ef.

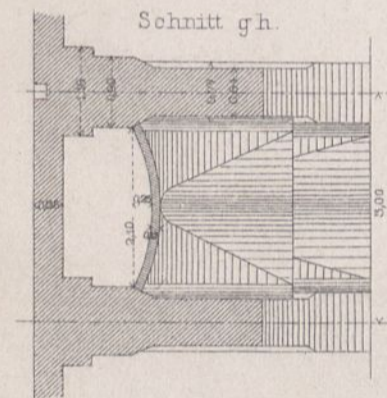

Schnitt gh.

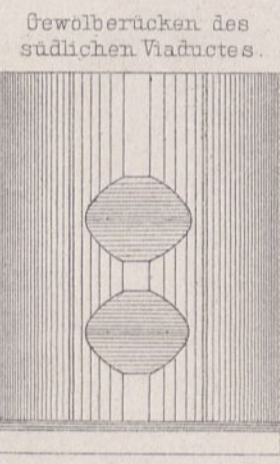

Gewölberücken des südlichen Viaductes.

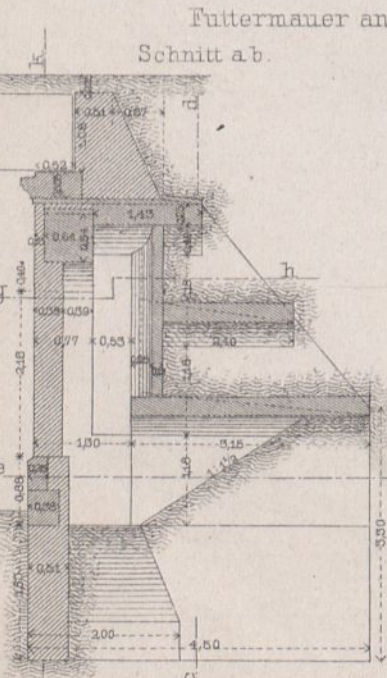

Schnitt ab.

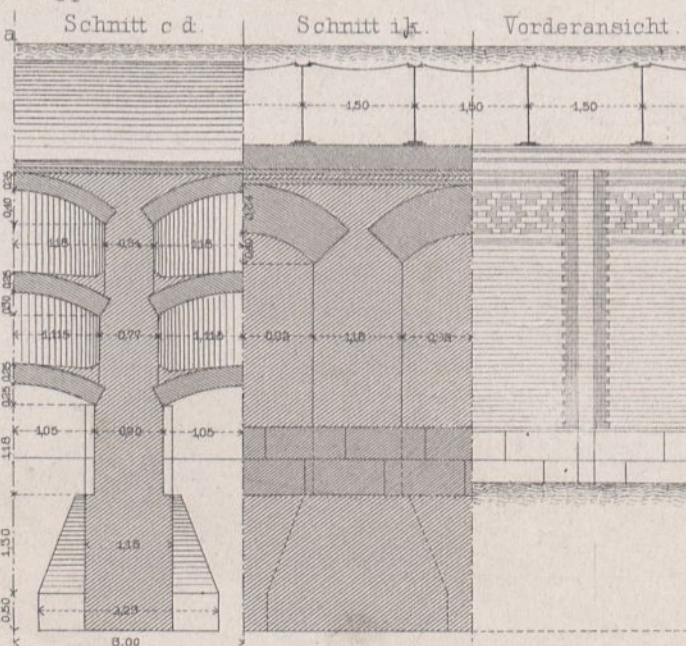

Schnitt cd.

Schnitt ik.

Vorderansicht.

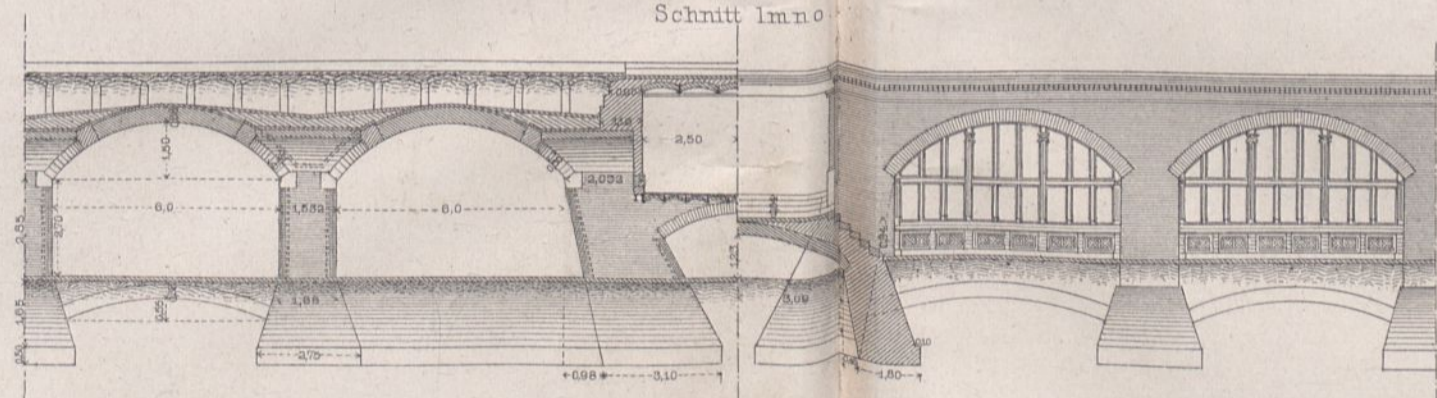

Schnitt lmno

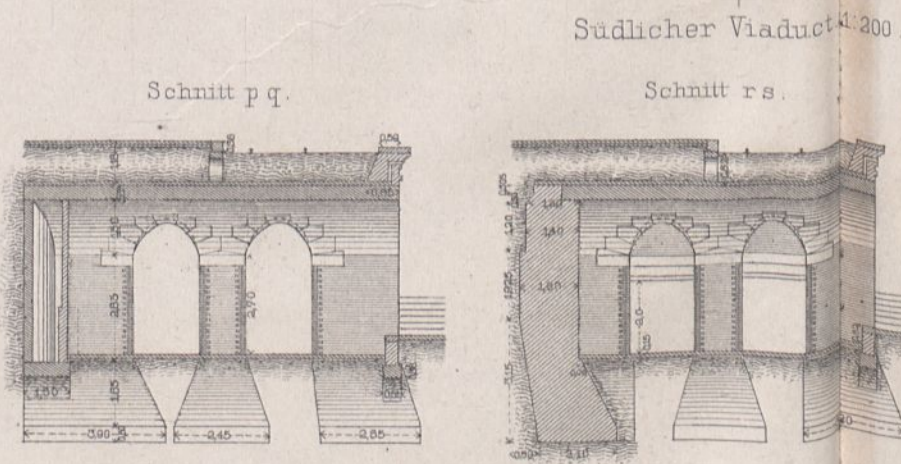

Schnitt pq.

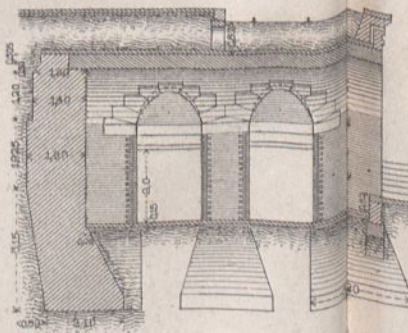

Schnitt rs.

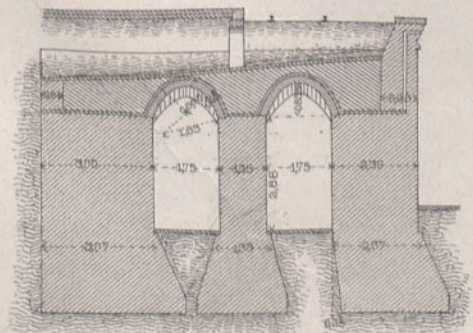

Schnitt tu.

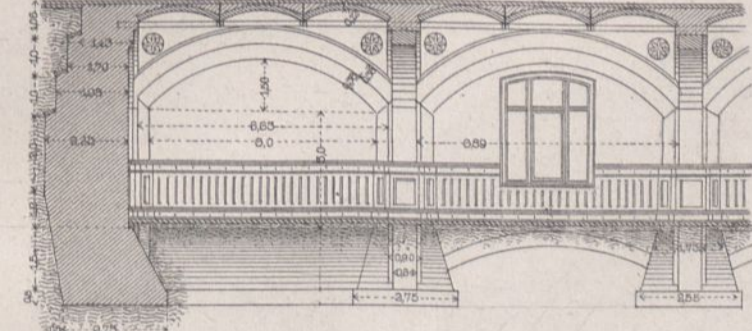

Schnitt vw

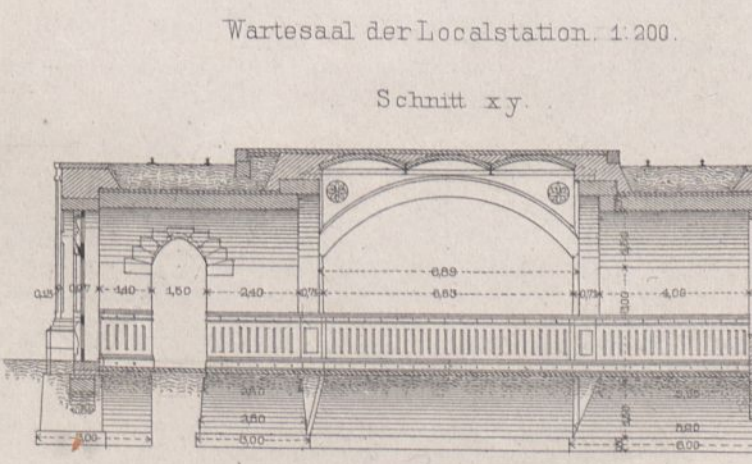

Schnitt xy

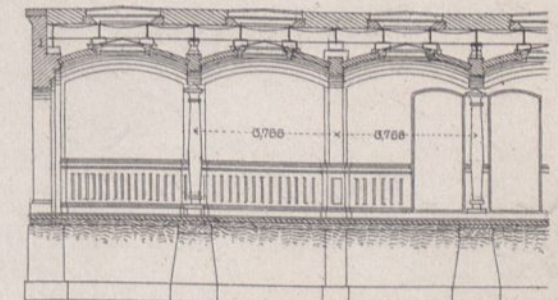

Schnitt AB

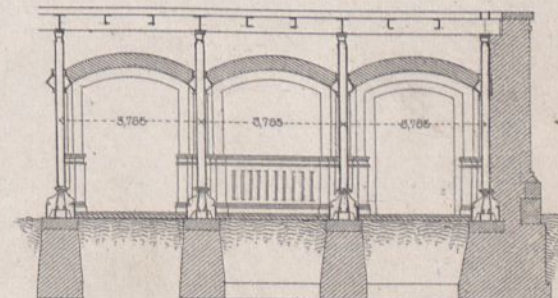

Schnitt CD

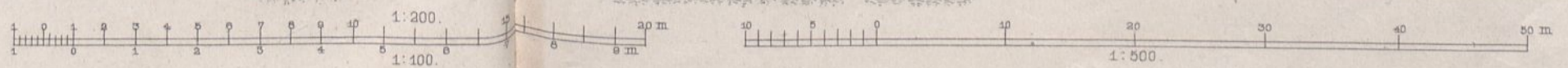

Bahnhof Alexanderplatz.

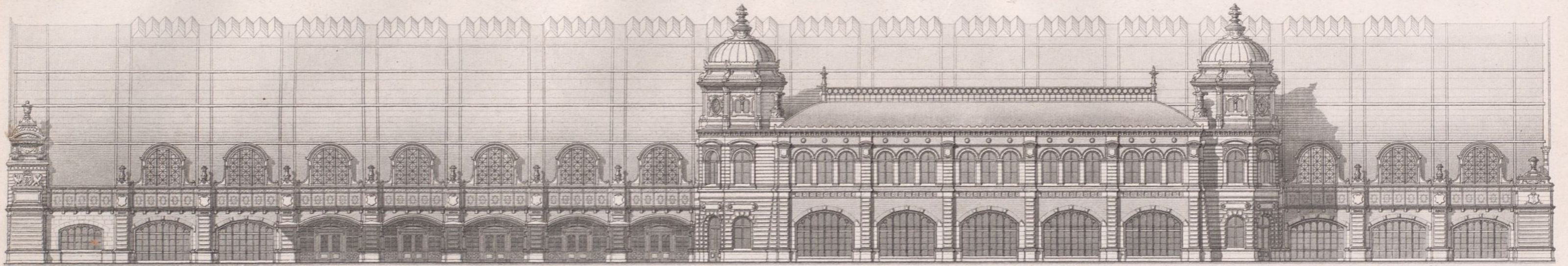

Ansicht.

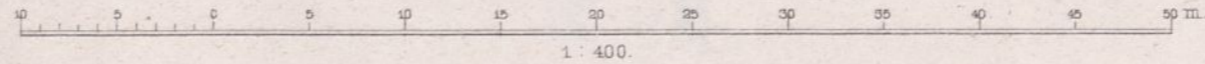

Grundriss.

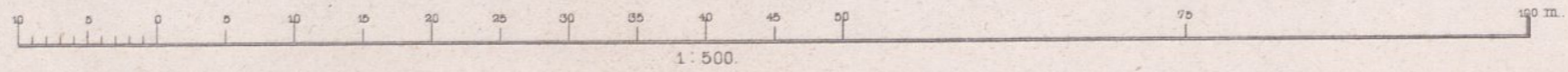
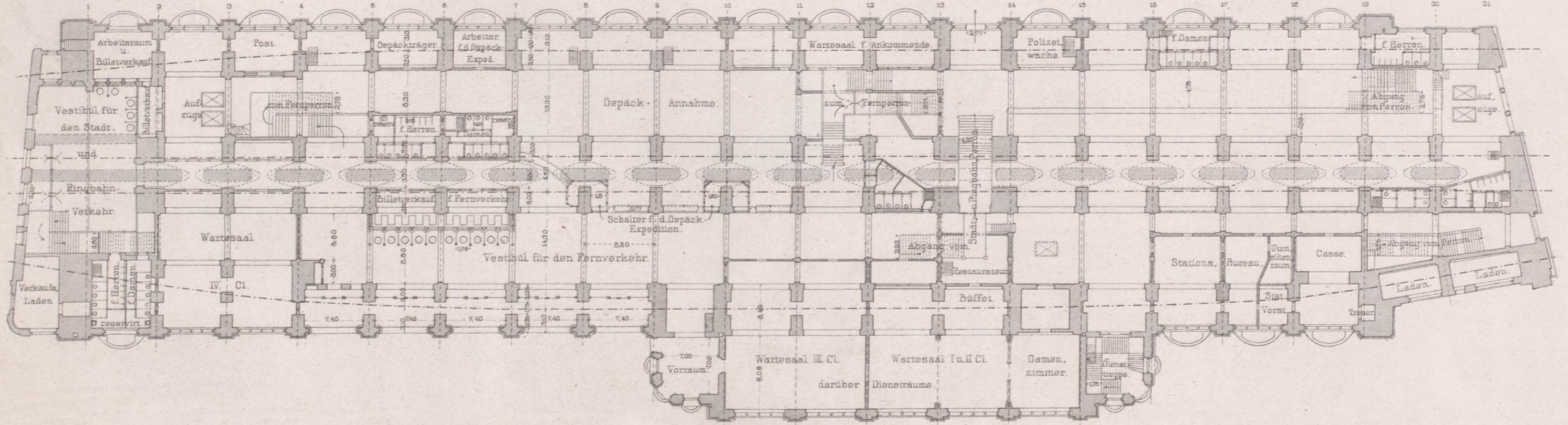

Arch. Gebr. Ritter u. Riegel.

Bahnhof Alexanderplatz.

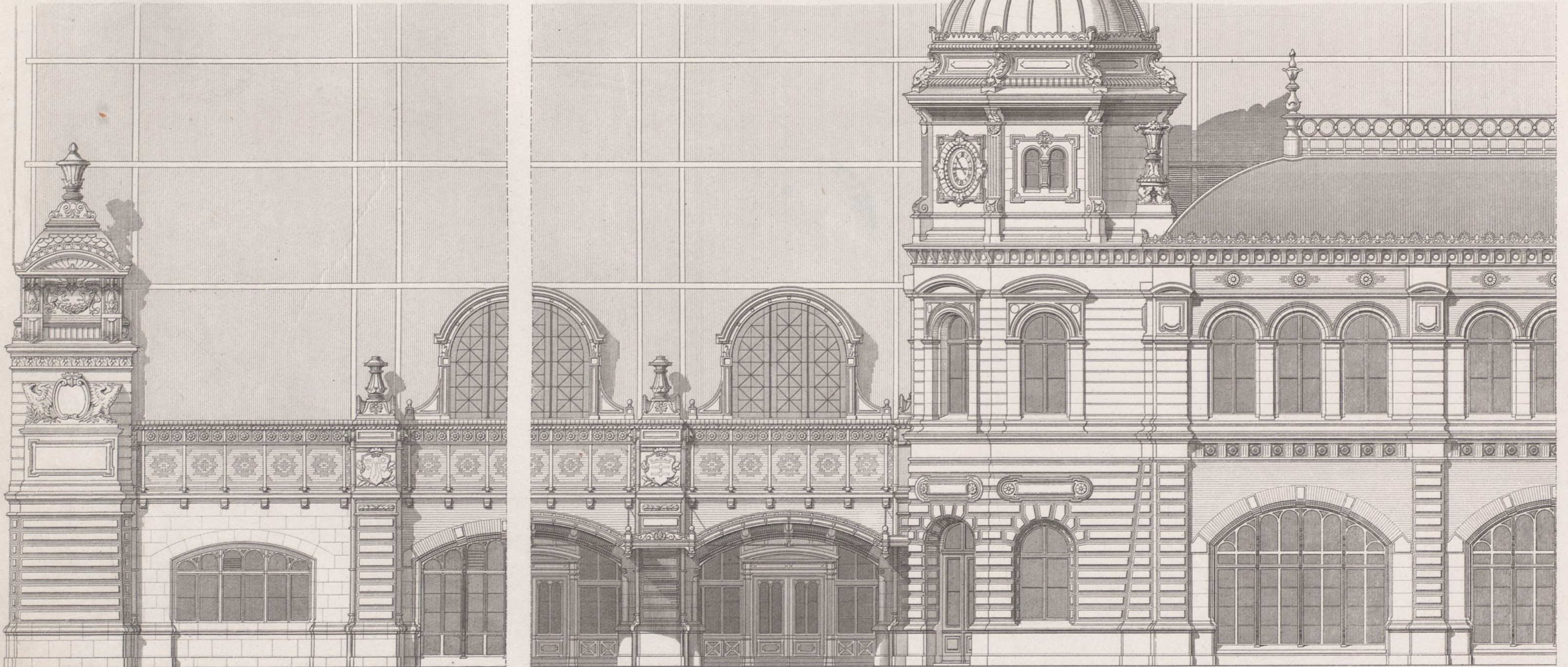

Systeme der Nordfaçade.

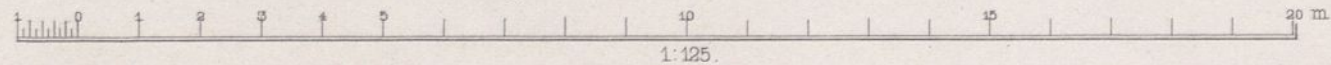

Ernst & Korn. Berlin.

Bahnhof Alexanderplatz.

Querschnitt zwischen Achse 7 u. 8.

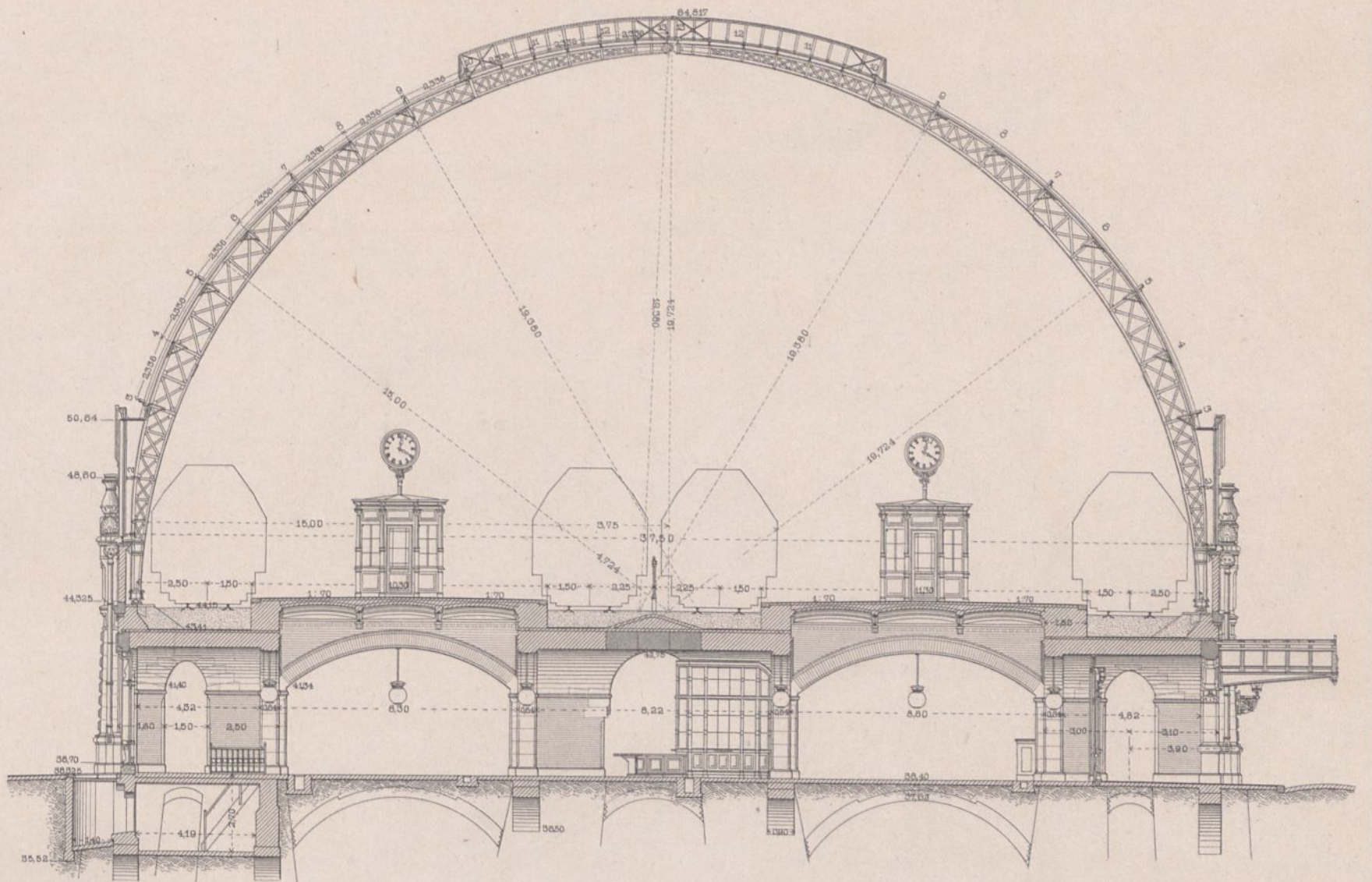

Querschnitt durch die Pfeiler 8.

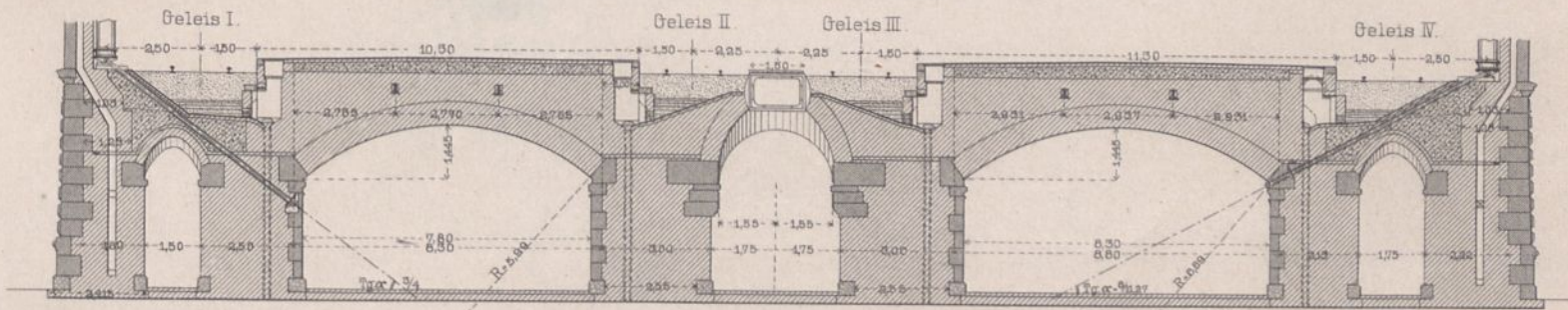

Längenschnitt durch die Mitte der Pfeilerdurchbrechungen der Viaducte

Nördlicher Viaduct

Mittlerer Viaduct

Südlicher Viaduct

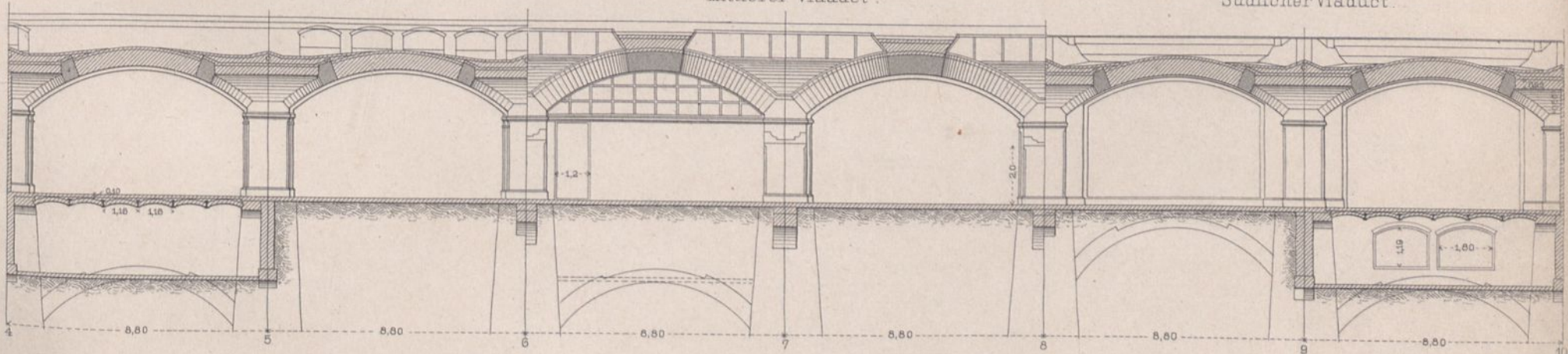

Oberer Grundriss

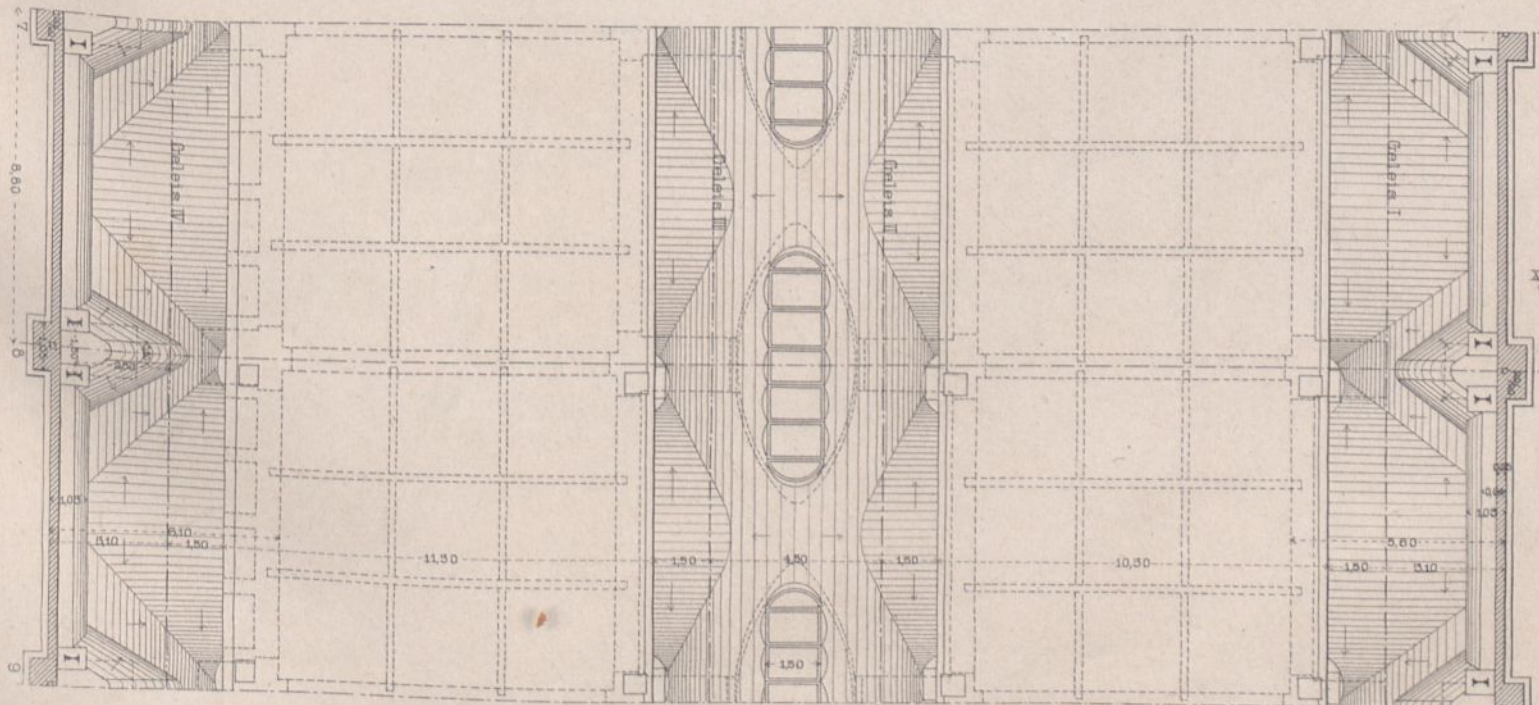

Normale Abwässerung

Querschnitt ab

Querschn. cd

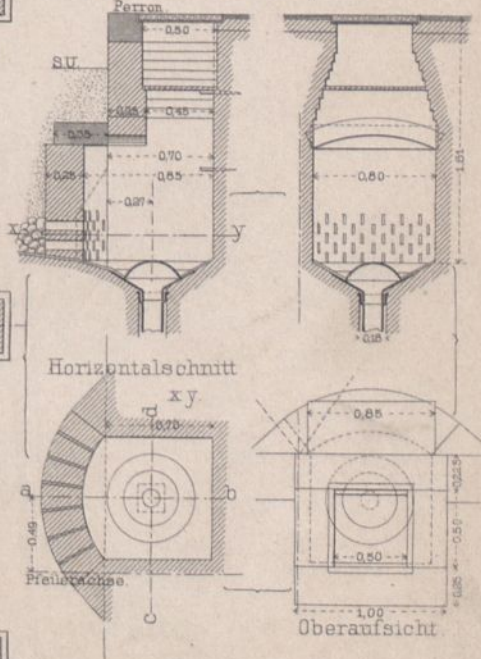

Haltestelle Börse.



Façaden-System.

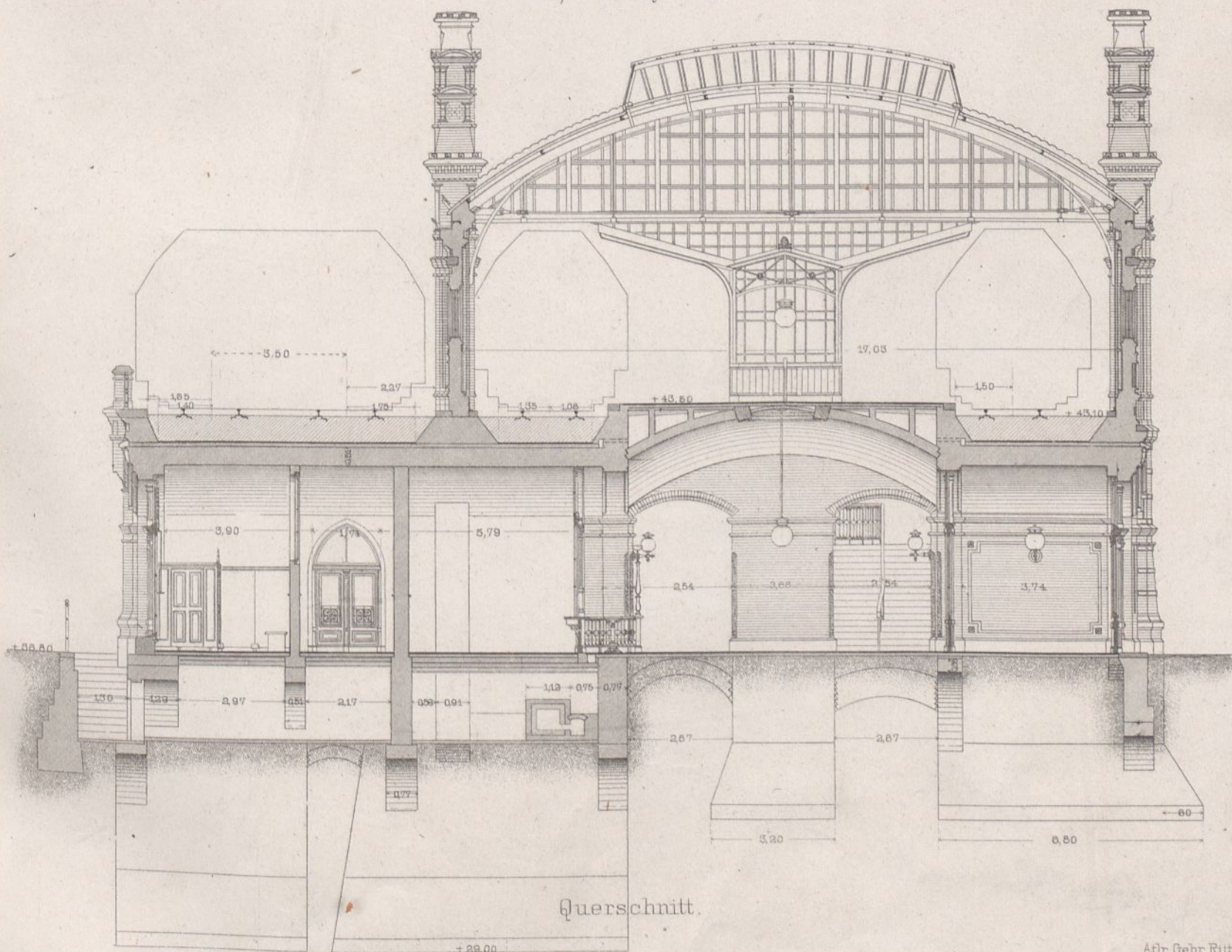

Querschnitt.

Arch. Gebr. Ritter u. Riegel.

1:150. 0 1 2 3 4 5 6 7 8 9 10 m.

1:75. 0 1 2 3 4 m.

Die Vorfluthbrücke.

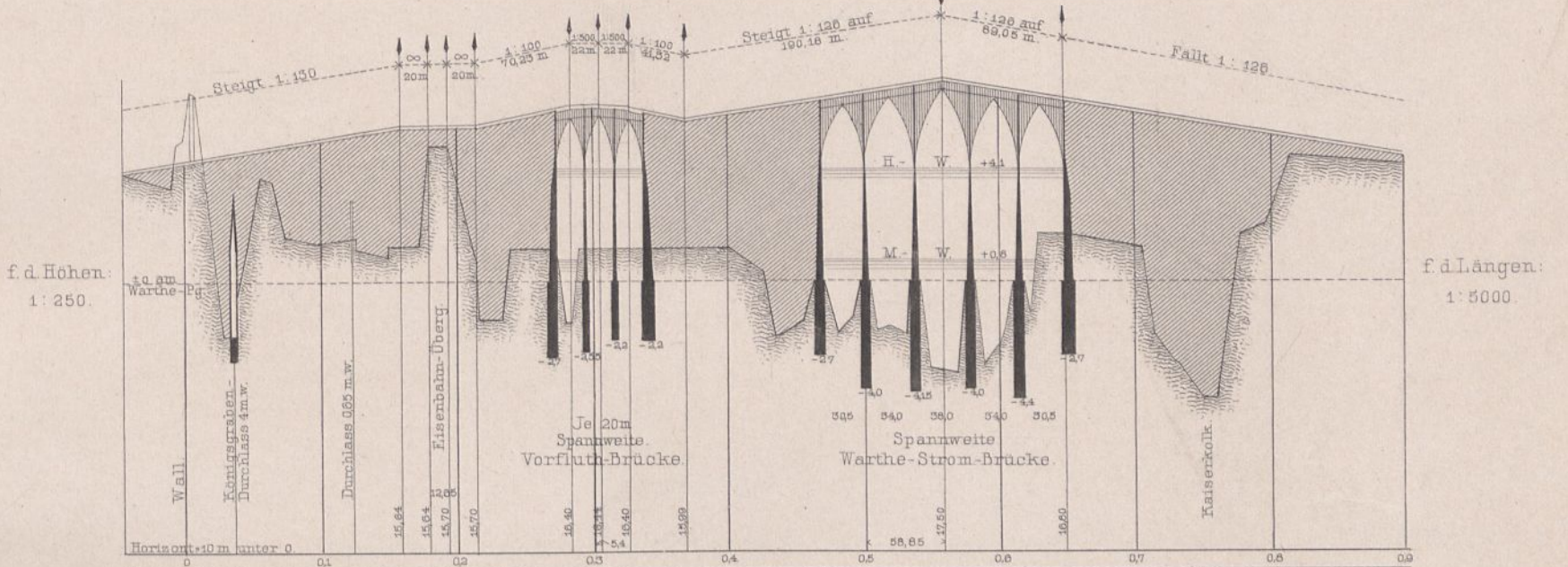
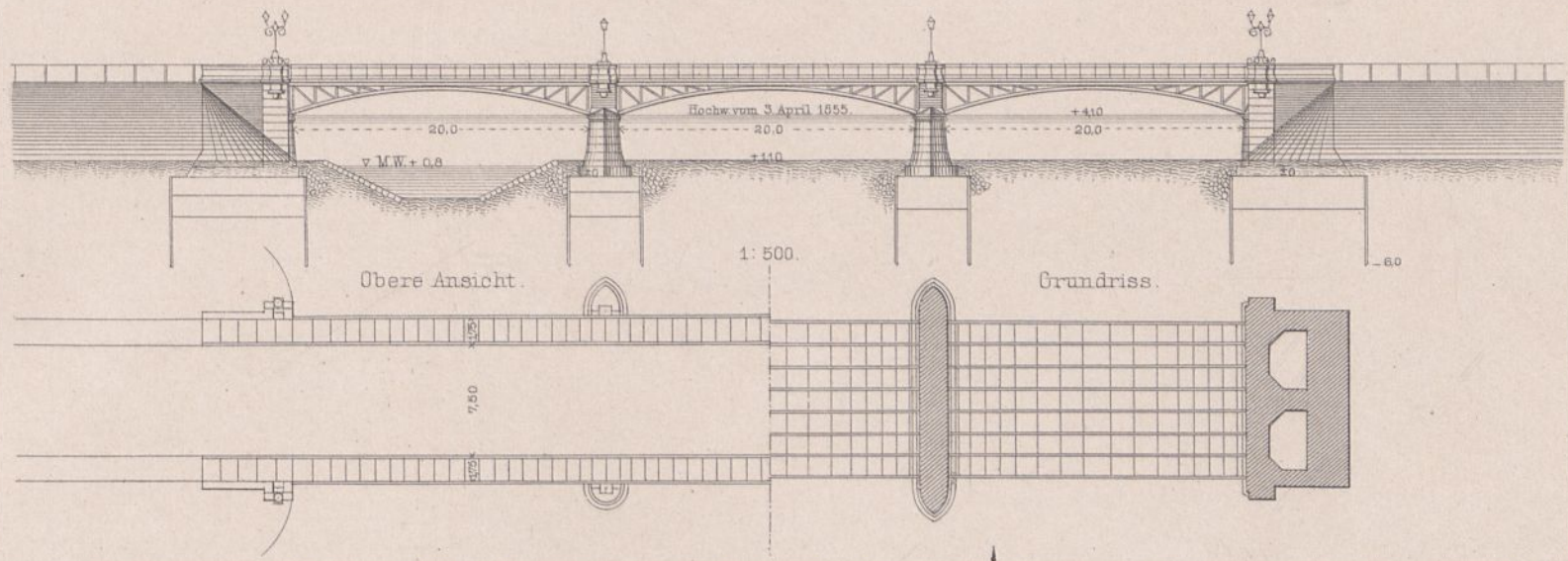

Längenprofil der neuen Strasse. (1:250)

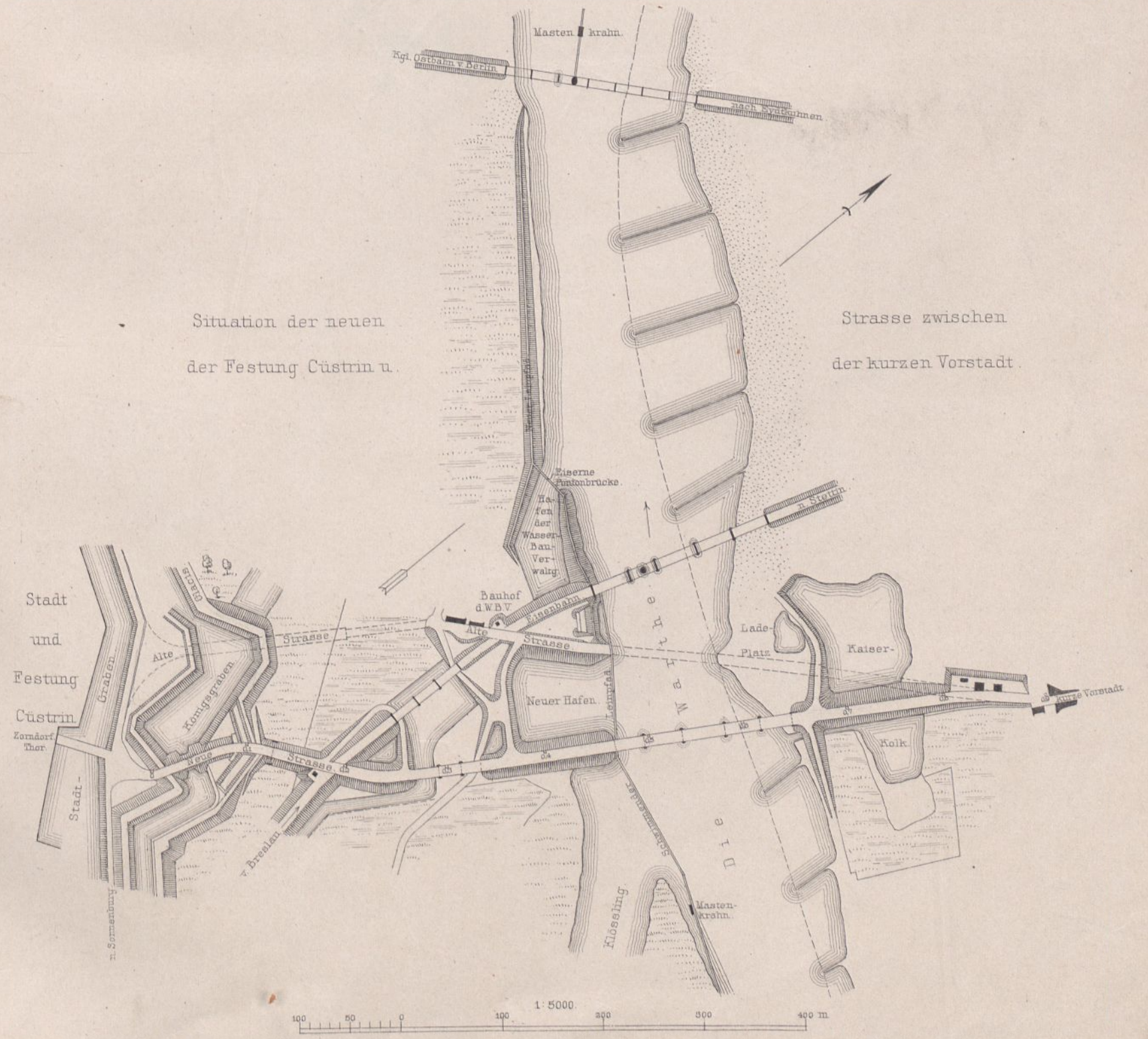

Die Strombrücke.

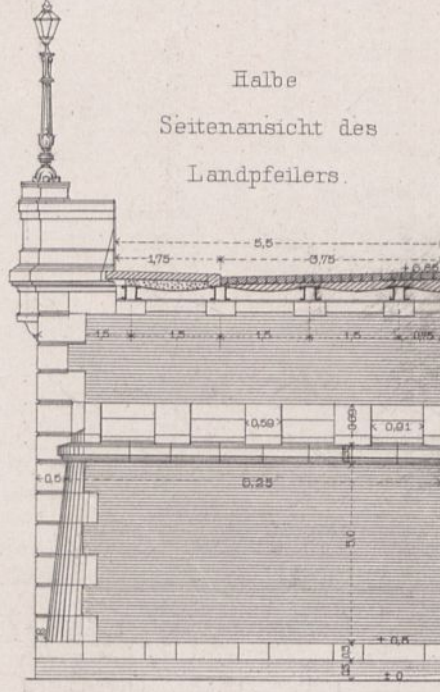
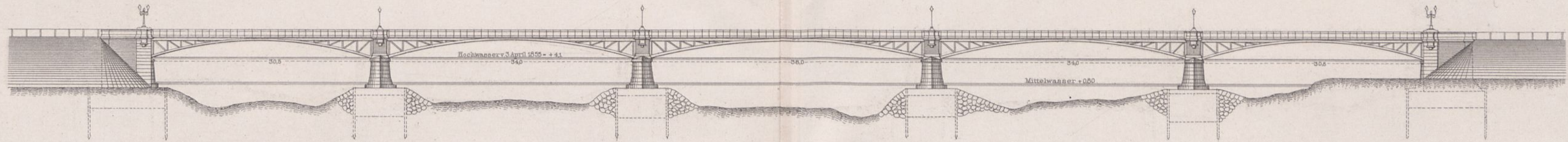

Ansicht der Öffnung I.

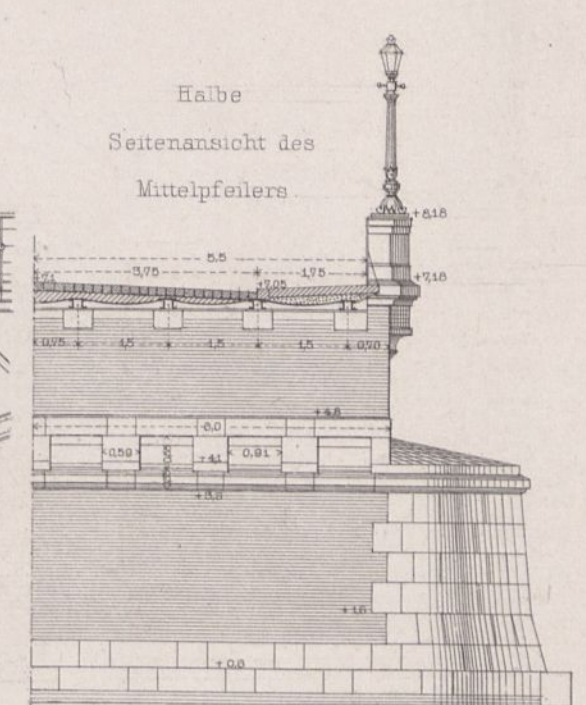
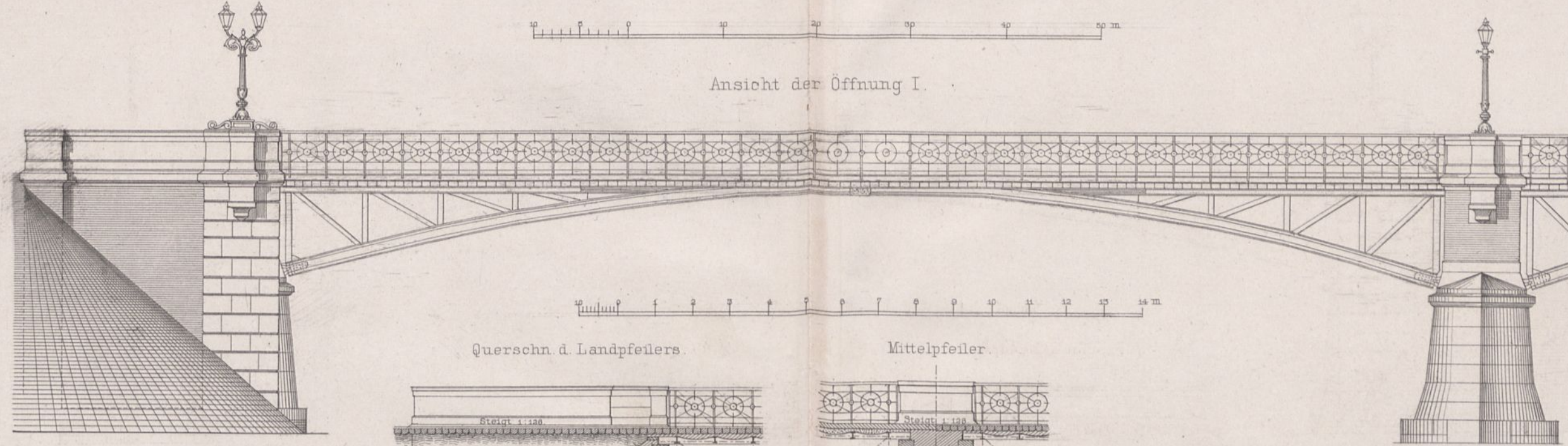

Querschn d. Landpfeilers.

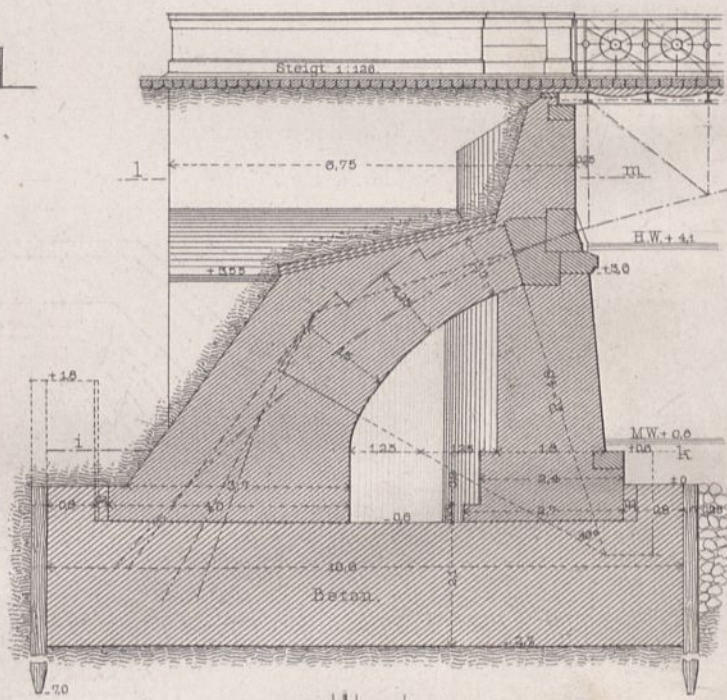

Mittelpfeiler.

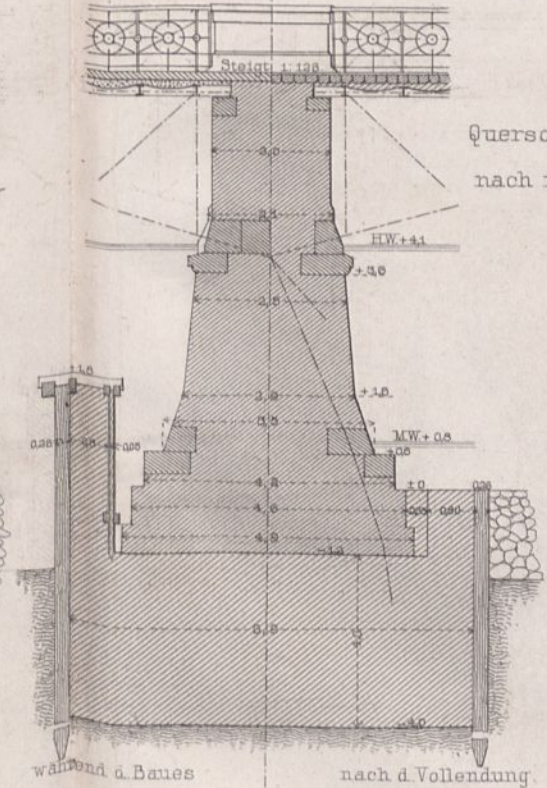

Querschn nach n.o.

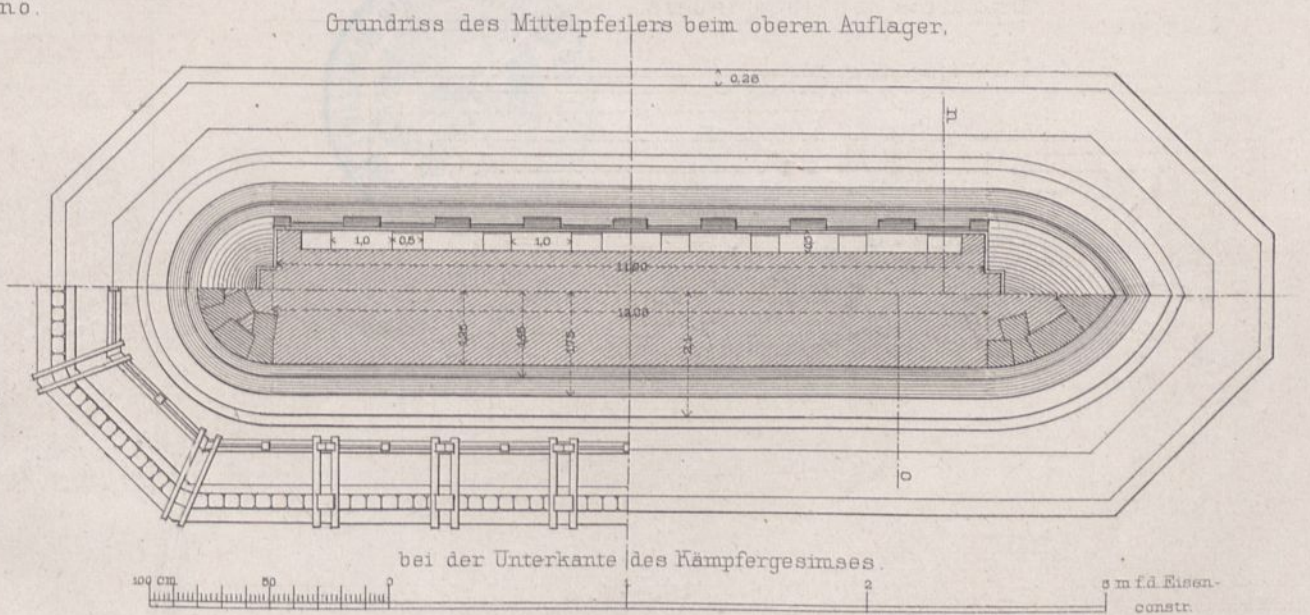

Grundriss des Landpfeilers

in 1:k, in 1:m.

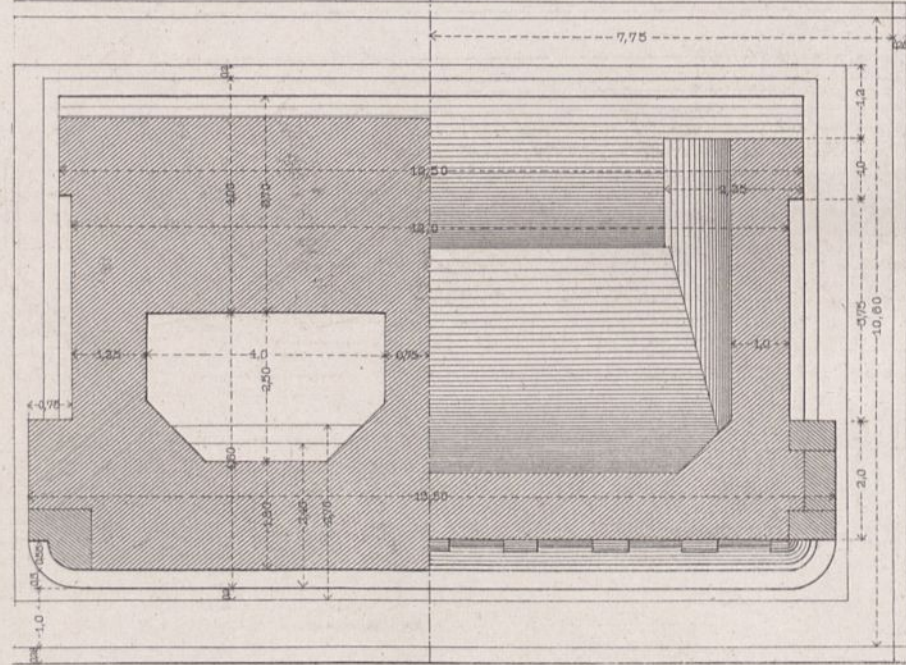

Anflager d. oberen Gurtung

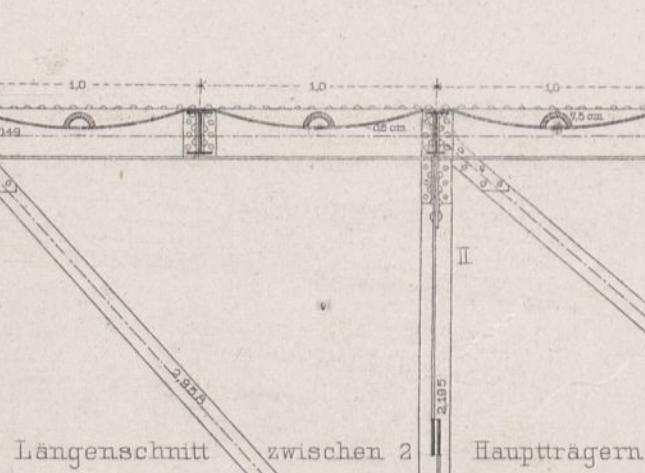
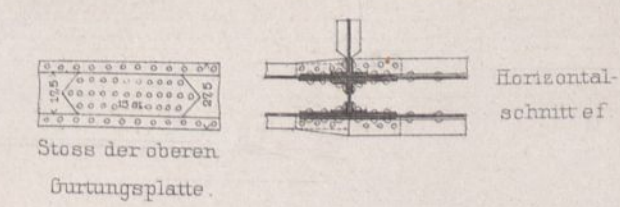
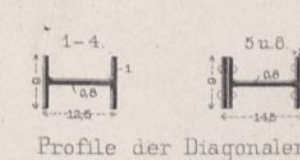
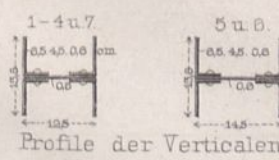
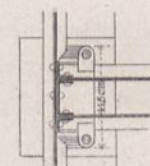

Ansicht von aussen.

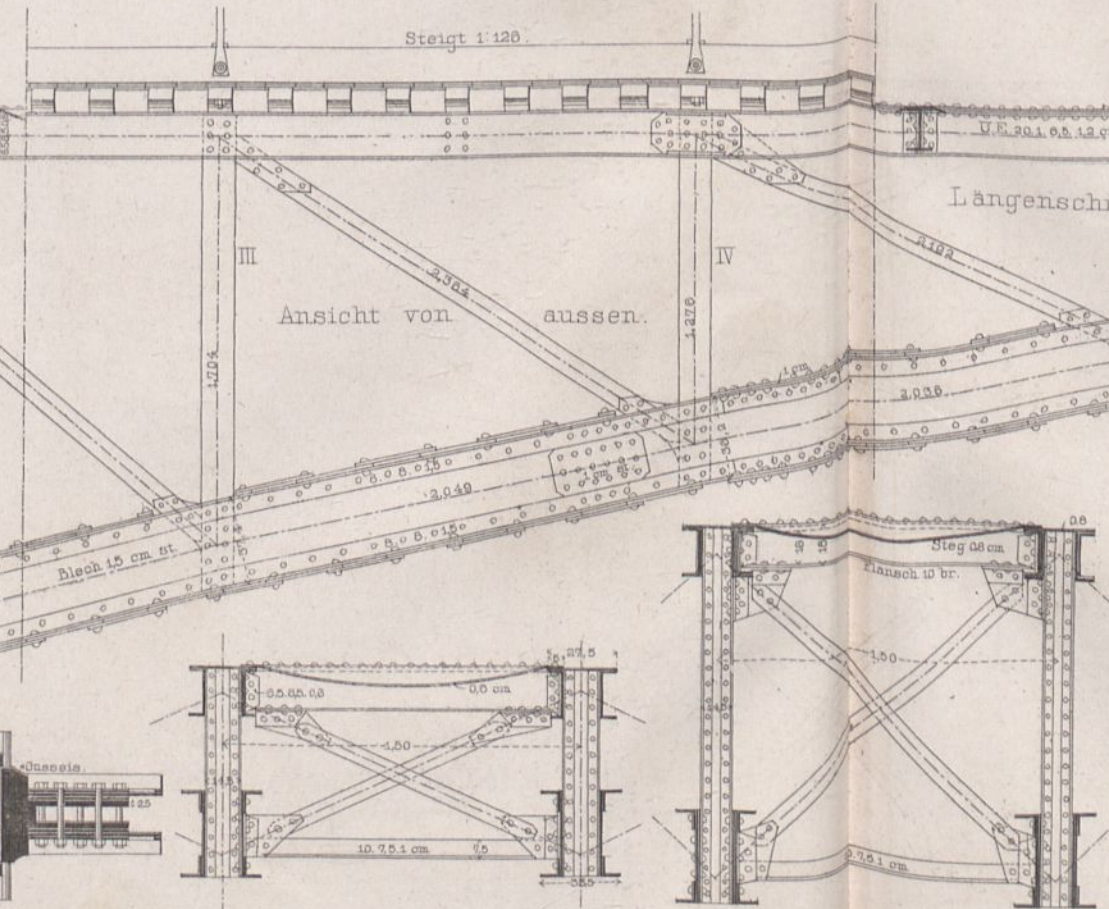

Längenschnitt zwischen 2 Hauptträgern.

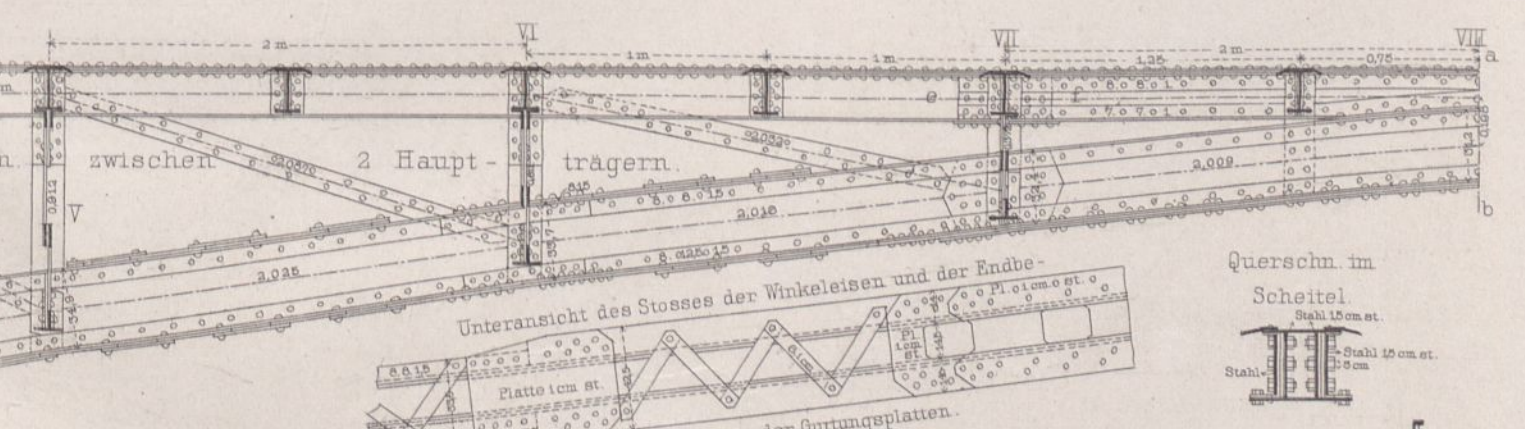

Querschn im Scheitel

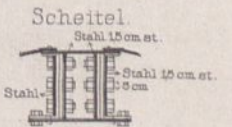

Querschnitt.

Übersicht.

Schnitt gh.

Querverbindung bei VI.

Querverbindung bei IV.

Querschnitt der halben Brücke bei c d.

Das Kurische Hauff.

Uebersichtsplan zur Beschreibung vom
Hafen zu Memel.

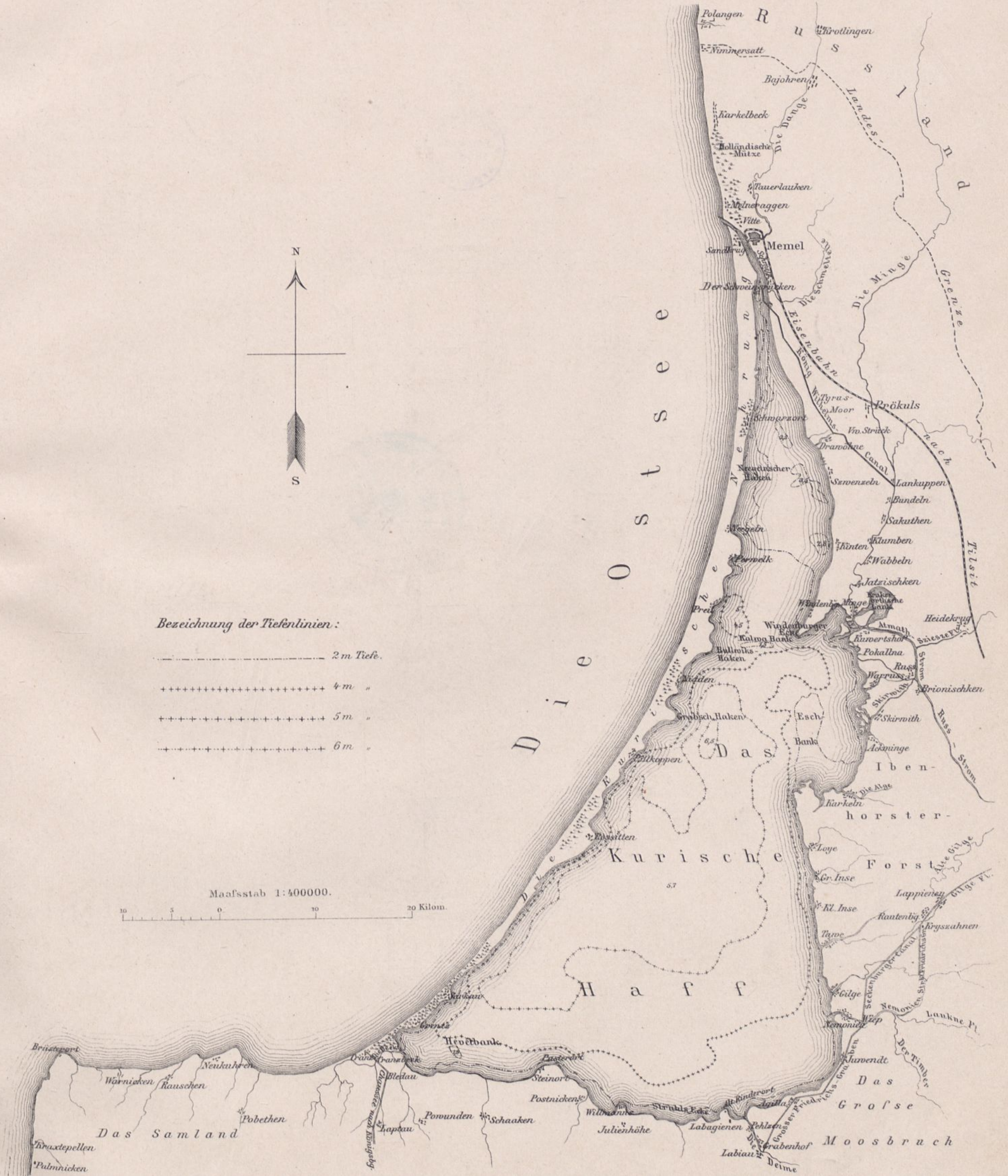

Der Hafen zu Memel.



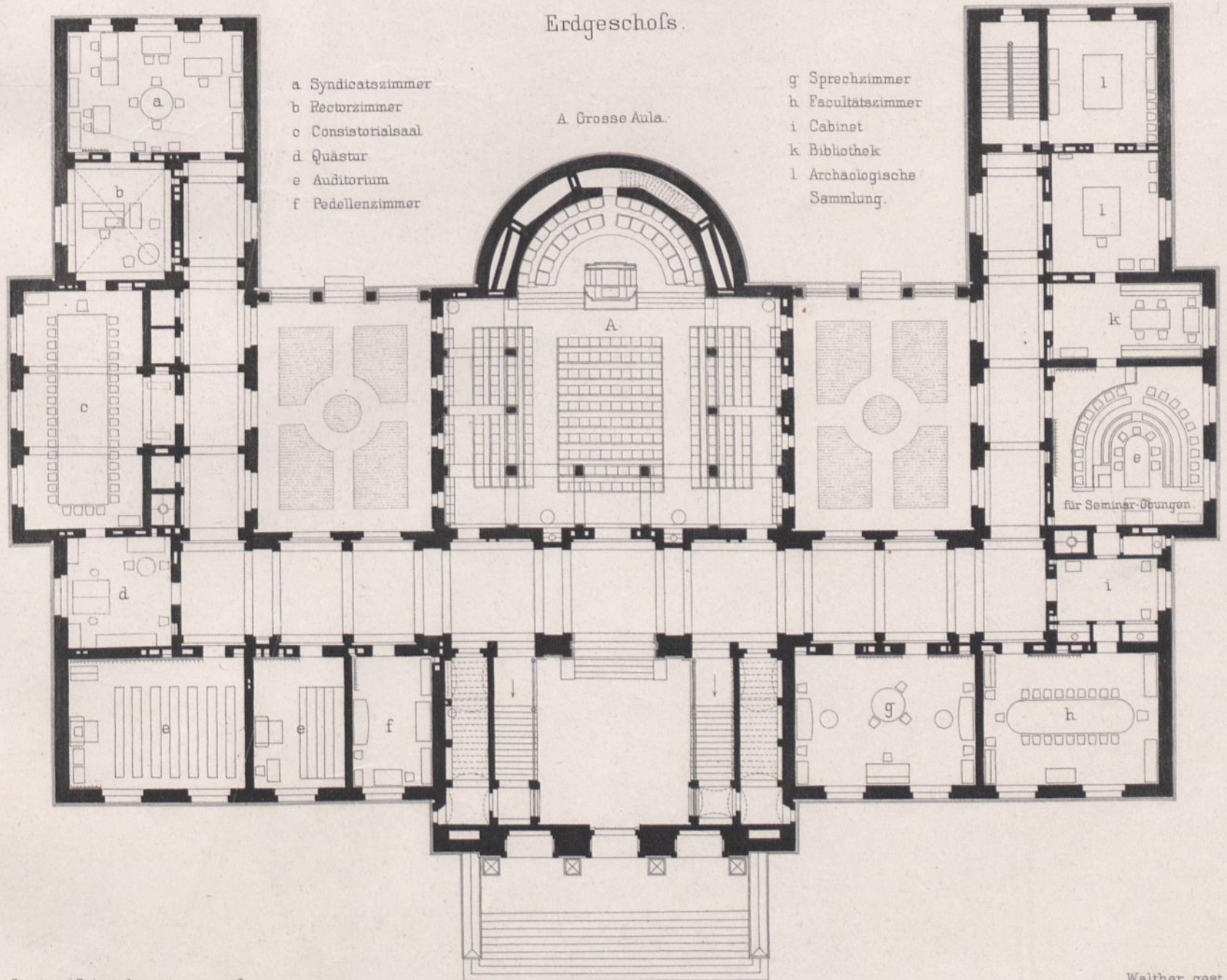
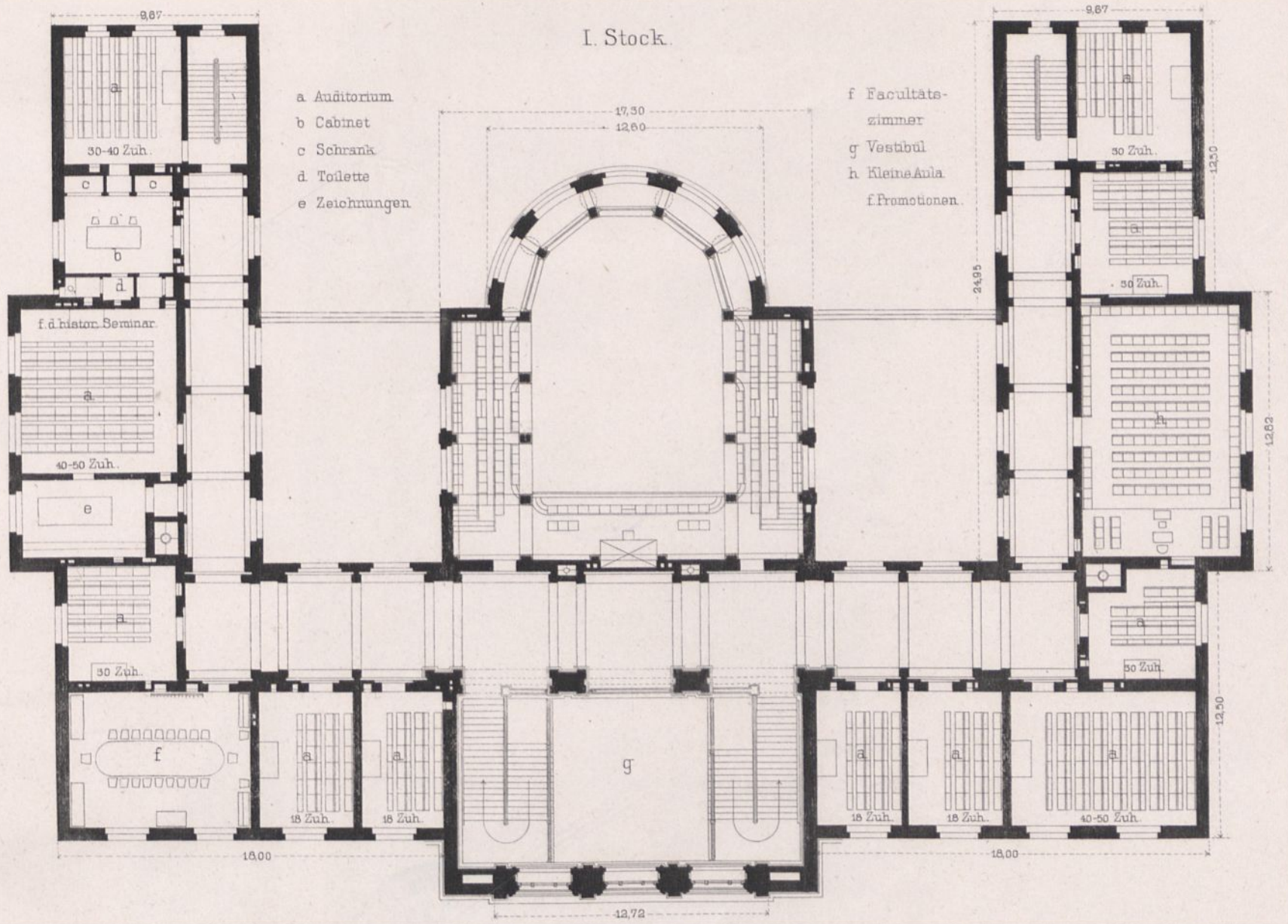

Gropius u. Schmieden entw u. ausgef.

Walther gest.

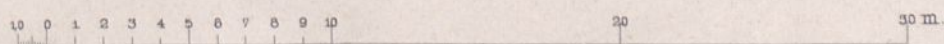



Universitätsgebäude in Kiel.

Vorder-Ansicht.

Oropius u. Schmieden entw. u. ausgef.

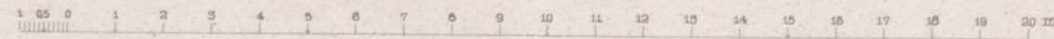

Arch. Gebr. Ritter u. Riegel.

Ernst & Korn. Berlin.

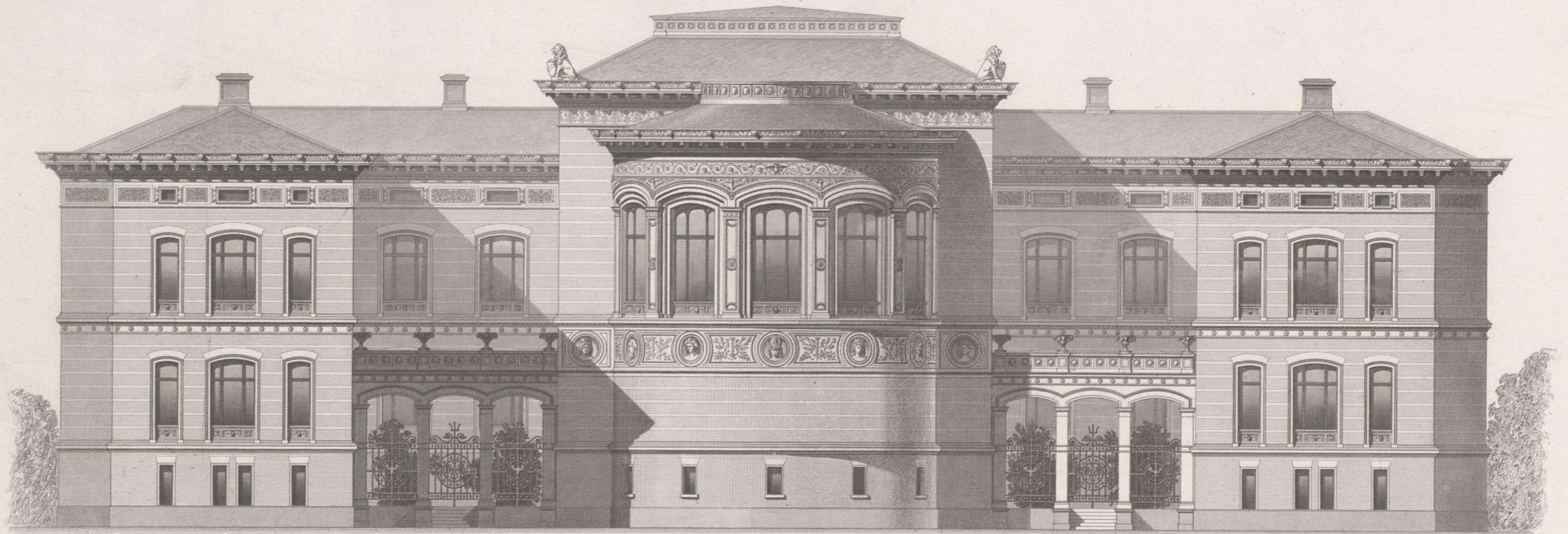

Hinter-Ansicht.

Gropius u. Schmieden Arch.

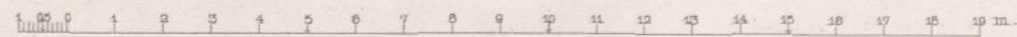

Arch. Gebr. Ritter u. Riegel.

Ernst & Korn. Berlin.

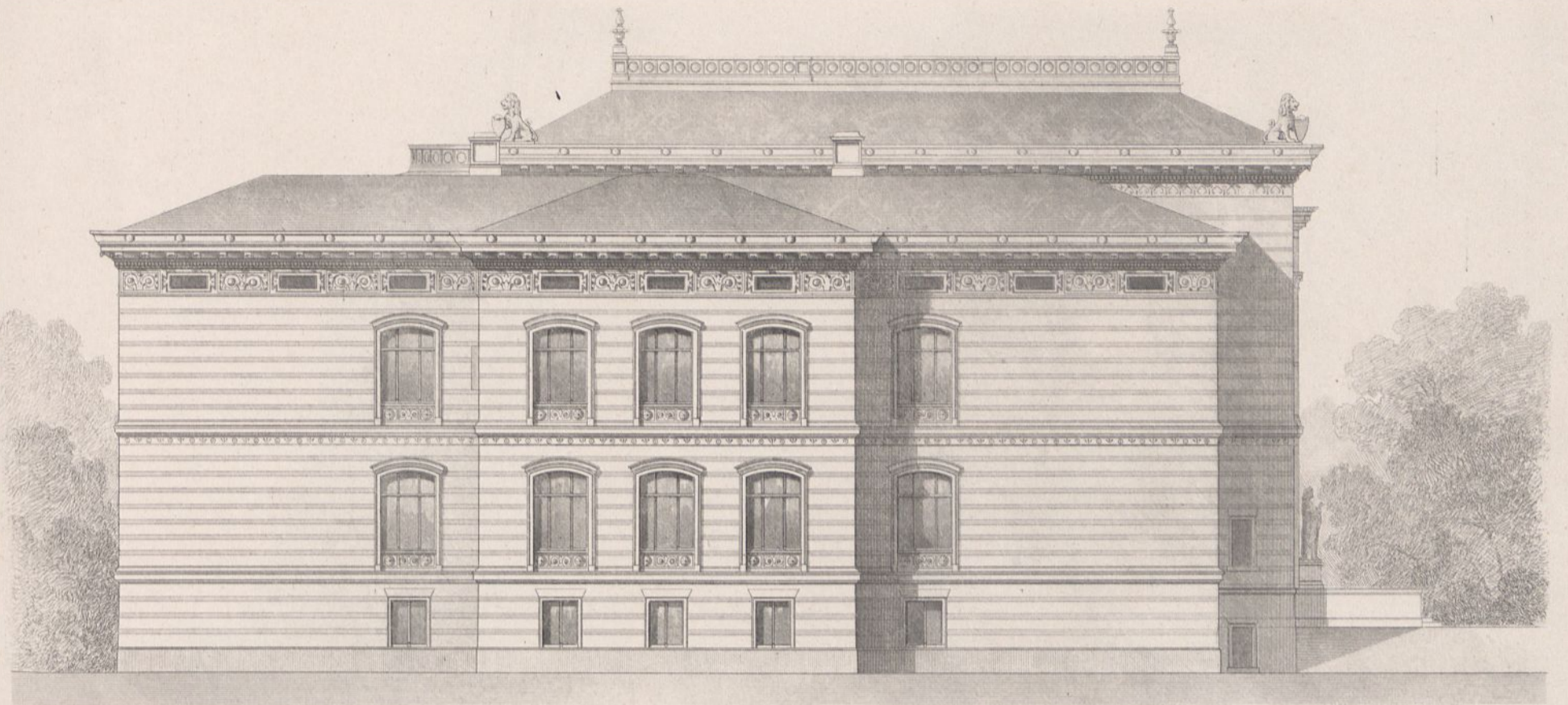

Seiten-Ansicht.

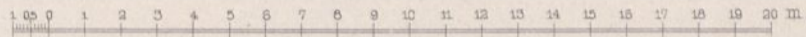

Querschnitt durch die grosse Aula.

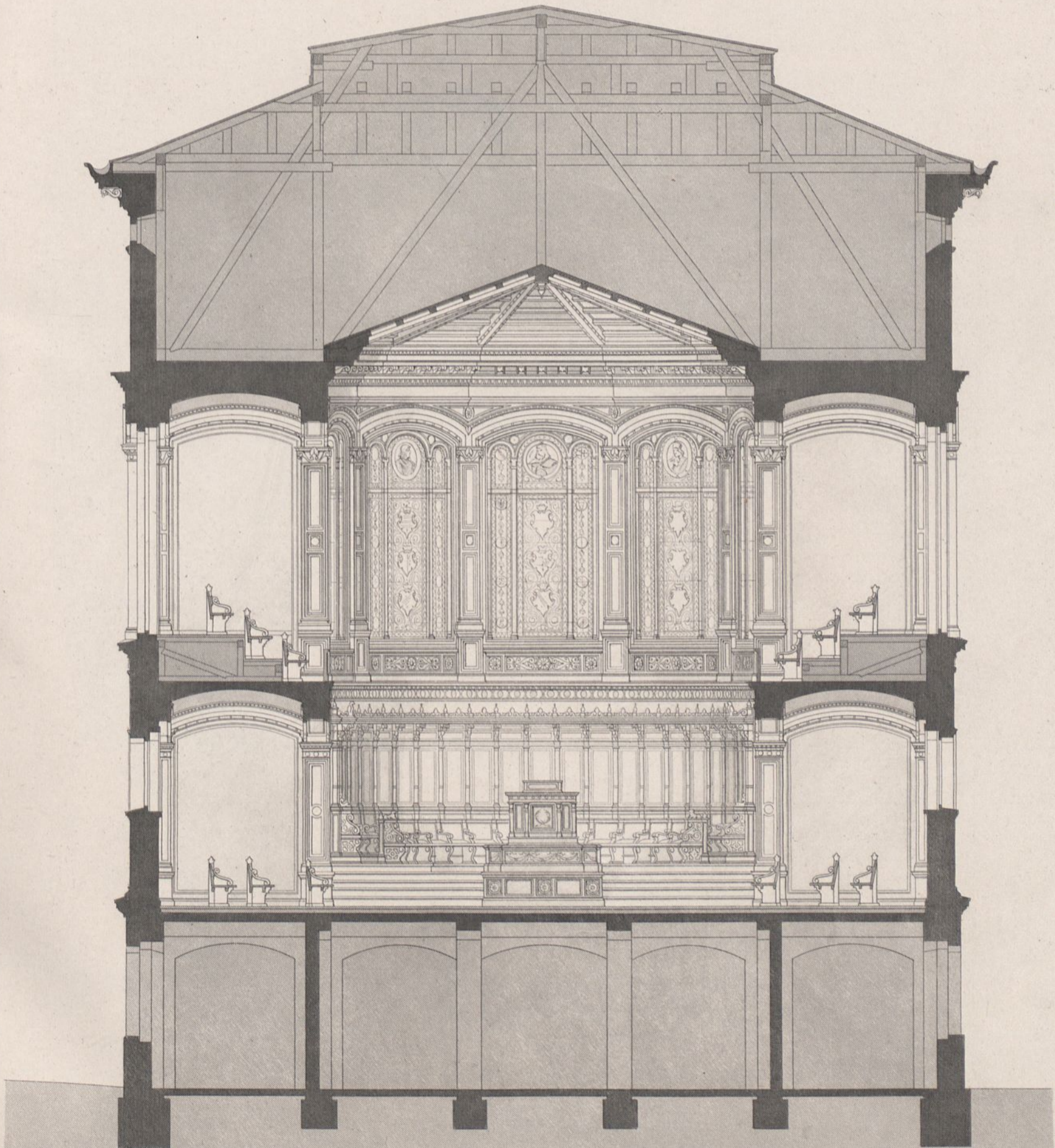

Gropius u. Schmieden Arch.

Atlr. Gebr. Ritter u. Riegel.

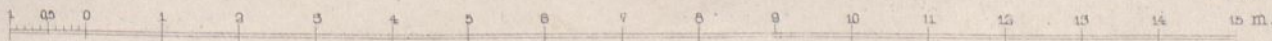

Schnitt durch den Mittelbau.

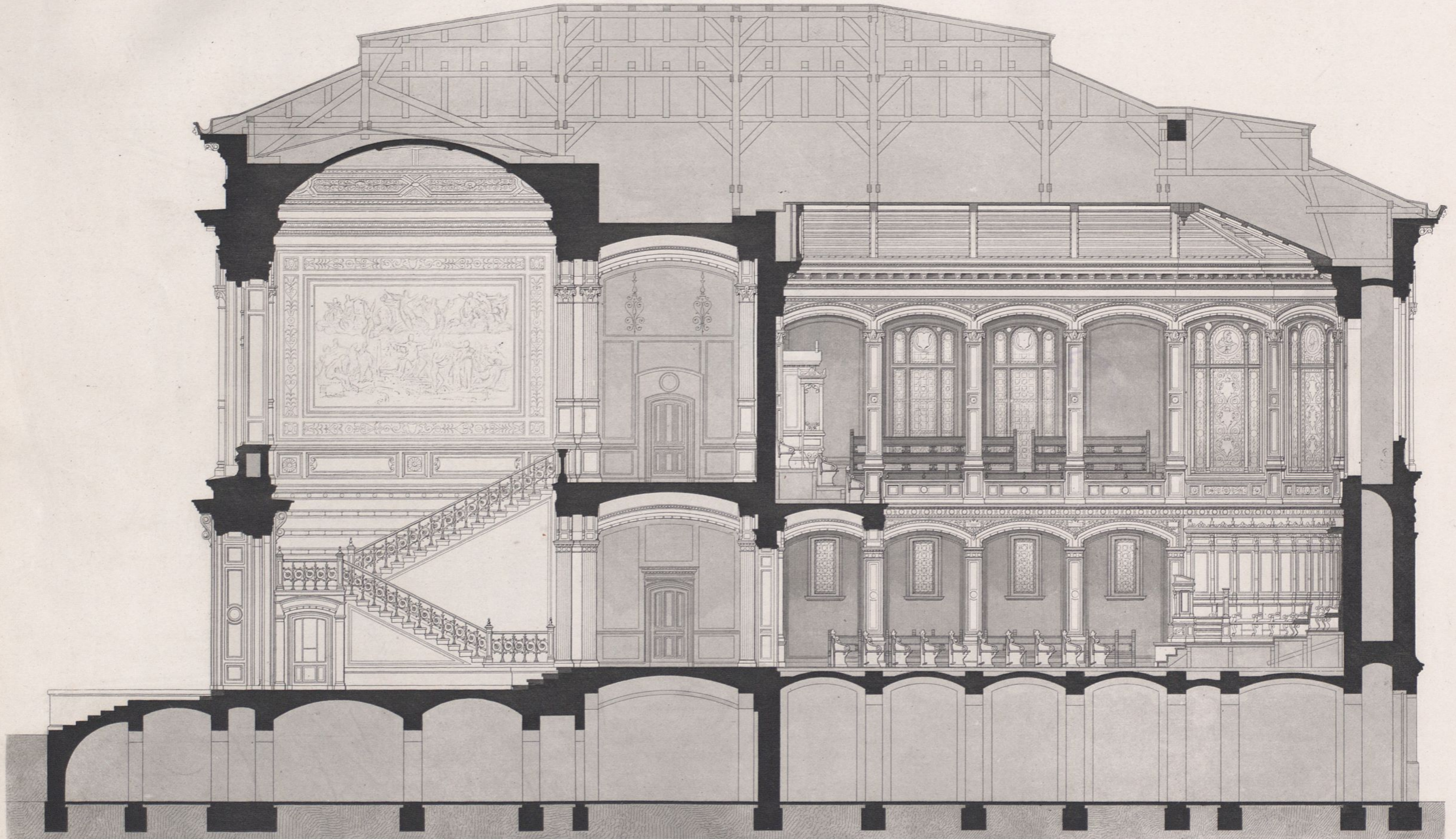

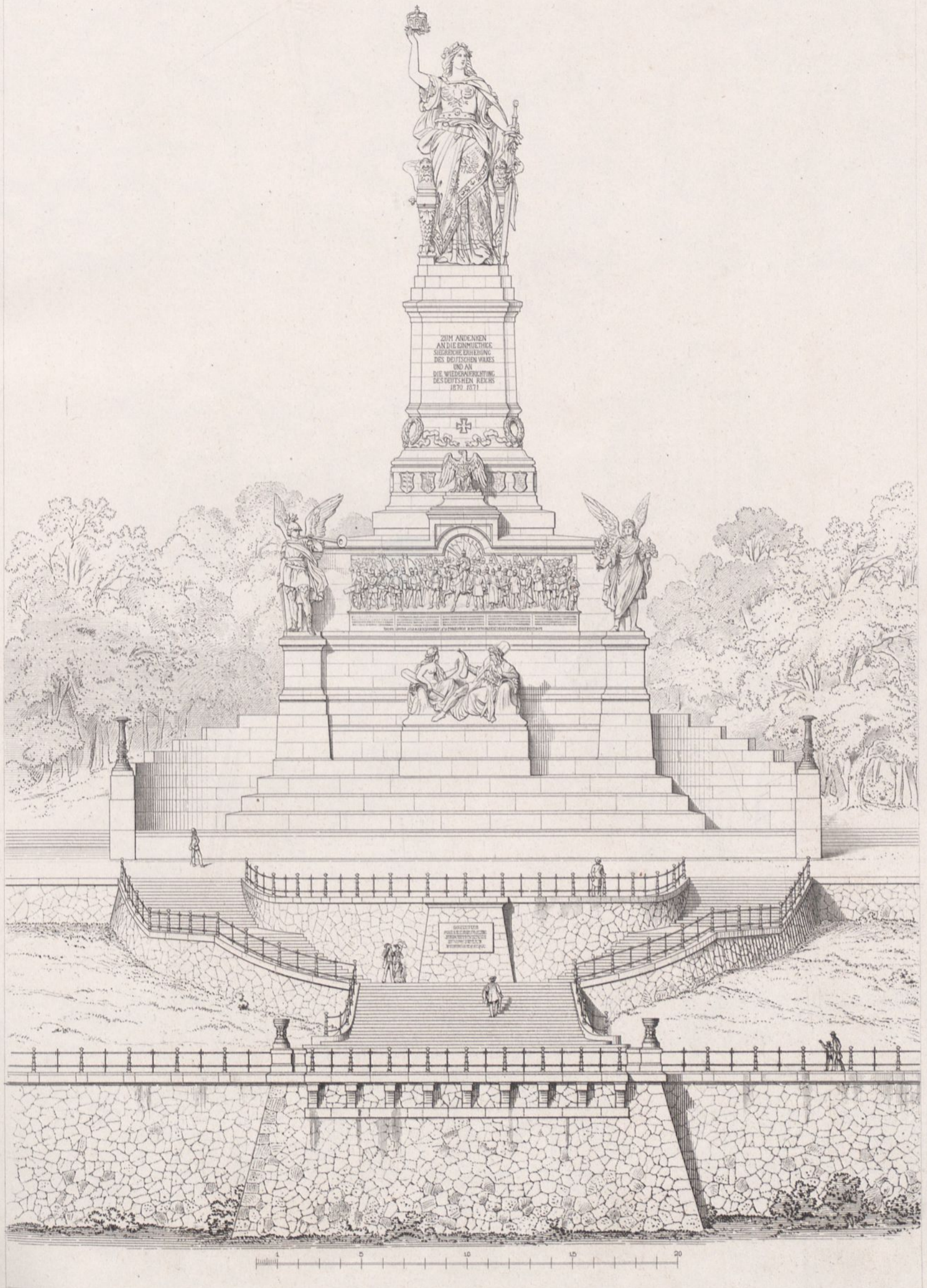

Johannes Schilling.
Architekt: Karl Weißbach.

Verlag von Ernst & Korn Berlin.

Das Nationaldenkmal auf dem Niederwald.

gez. Paul Ritter.
gest. Atir. Ritter u. Regel.

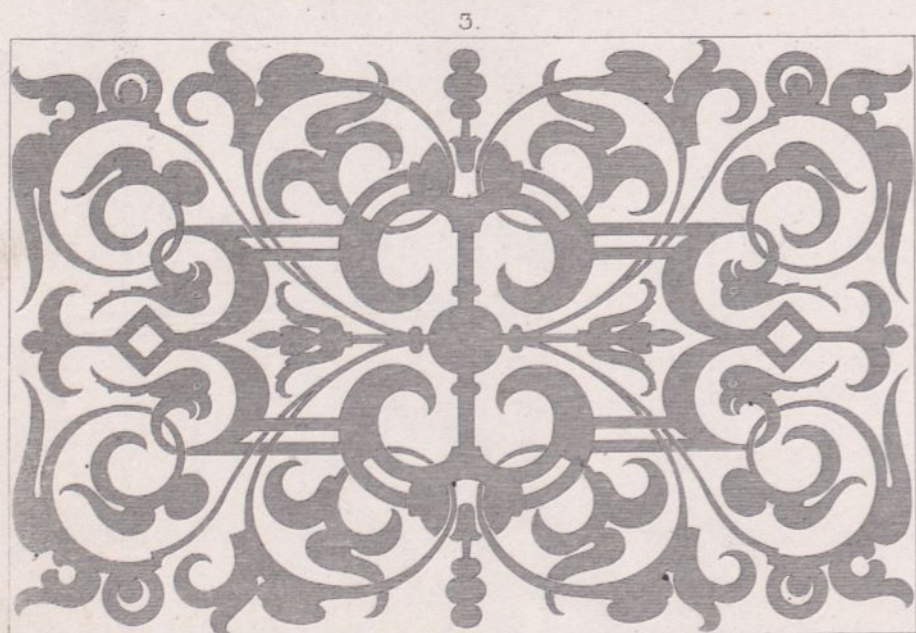
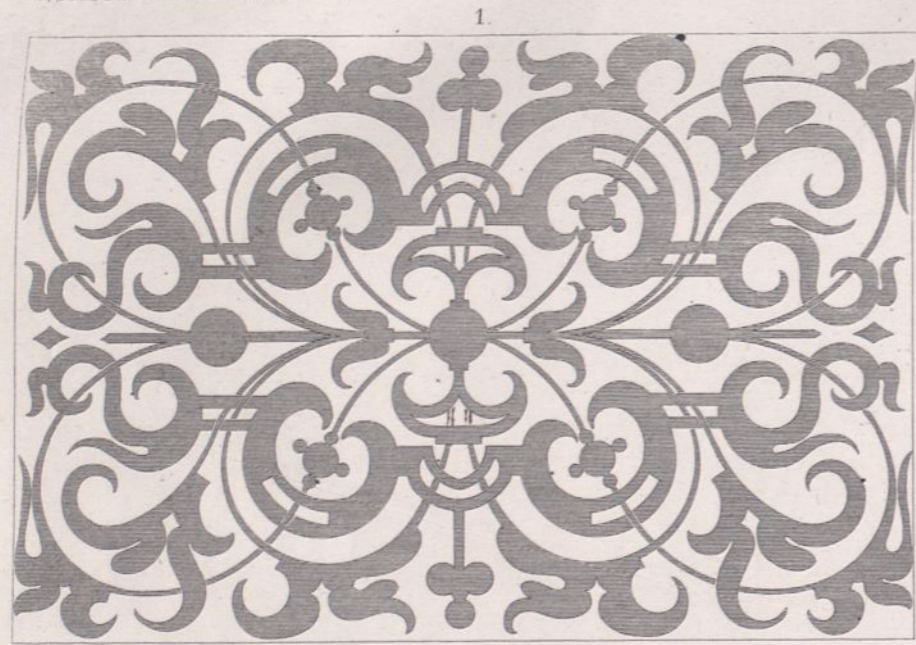

Flachornamente an der Decke
im Innern der
Johanniskirche in Leipzig.

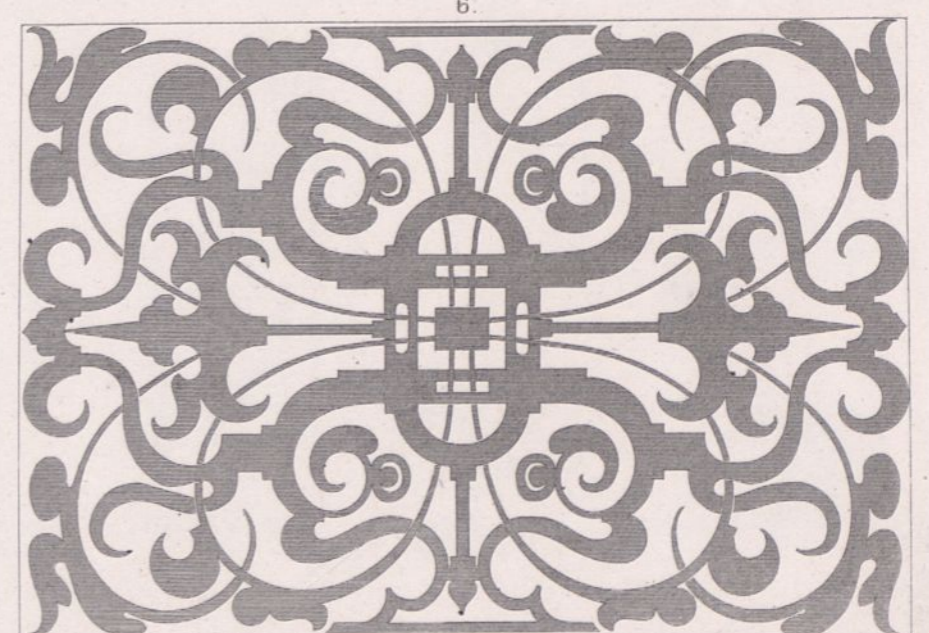
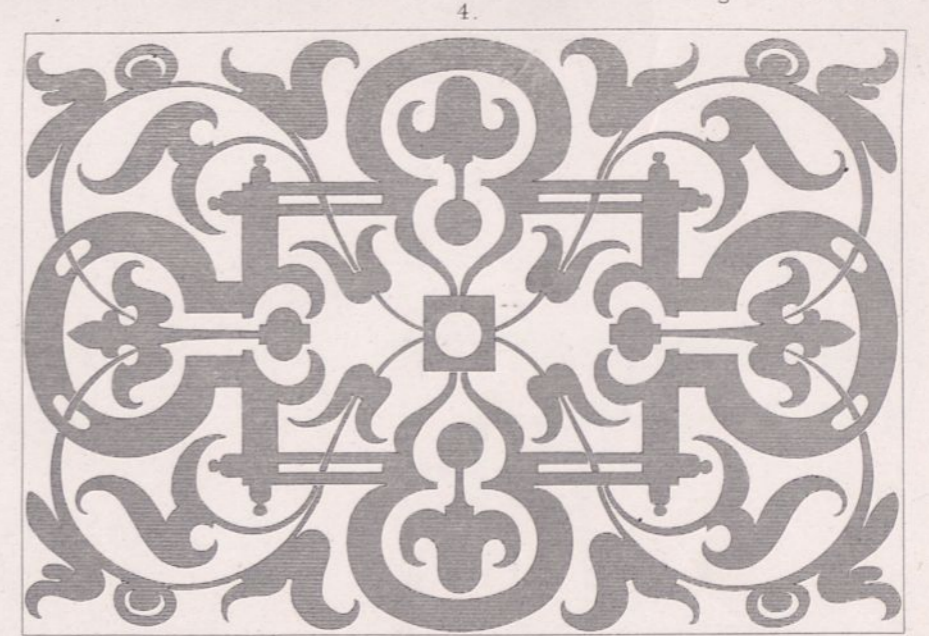
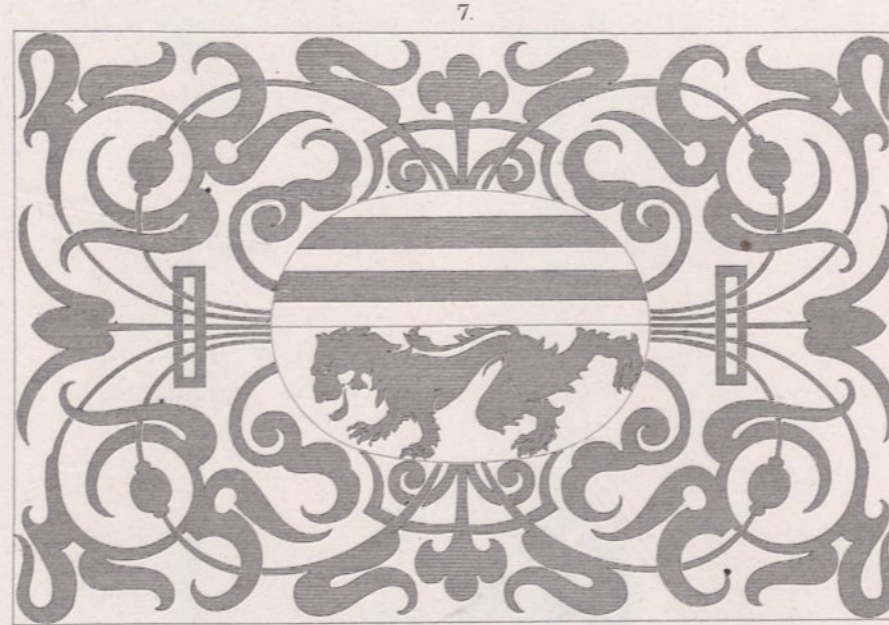

Grundriss der Kirche.

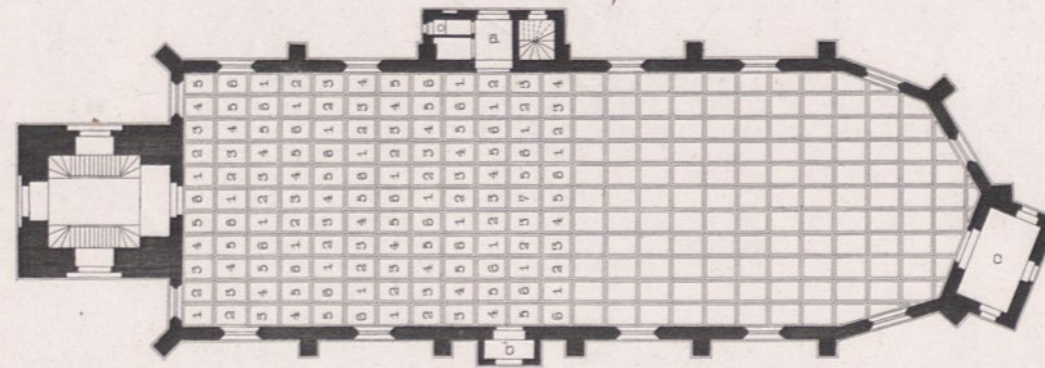

a, b, c sind Anbauten neuerer Zeit.

Maasstab der Ornamente 1/2 nat. Gr.

Maasstab für den Grundriss.

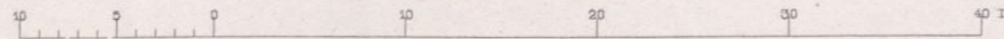

Schleusenanlage zu Bougival (Seine).

Fig. 3-8. Hydraulischer Cabstan zum Verholen der Schiffe

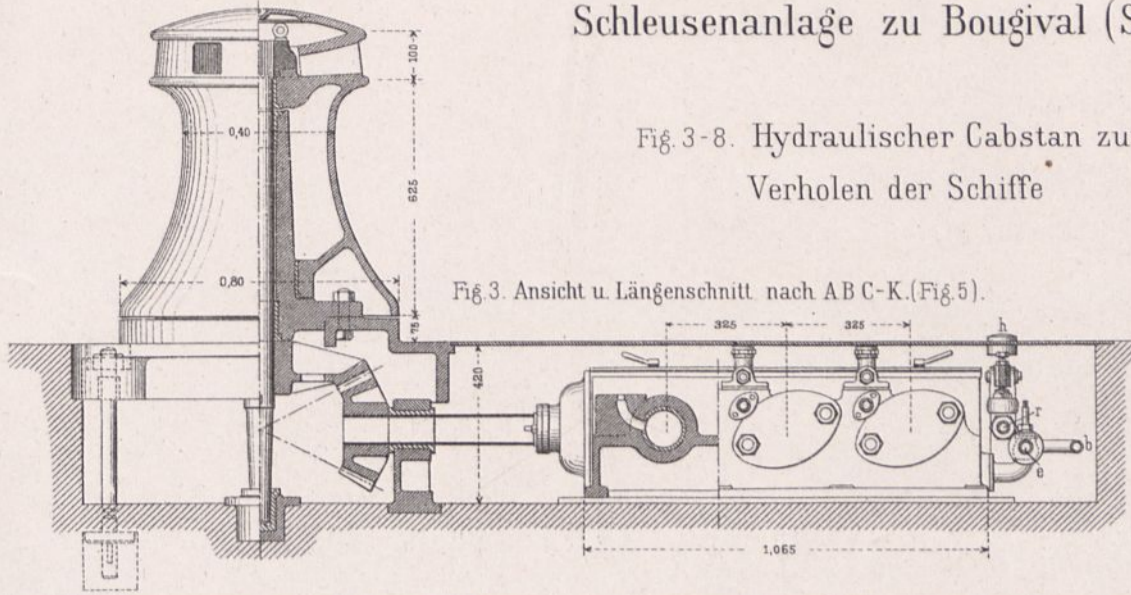

Fig. 3. Ansicht u. Längenschnitt nach ABC-K. (Fig. 5).

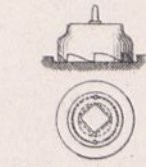

Fig. 7. Klauenhut.

Fig. 4. Schnitt nach OP. (Fig. 5).

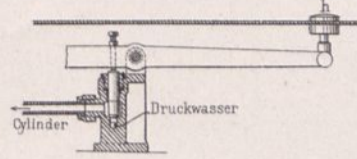

Fig. 6. Querschnitt nach LM. (Fig. 5).

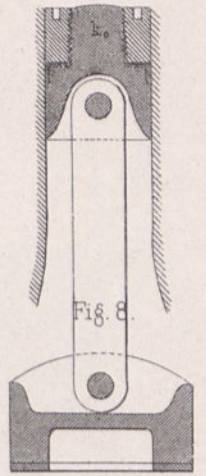
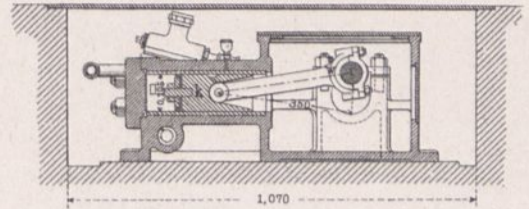

Fig. 8.

Fig. 11. Schnitt nach AB. (Fig. 10).

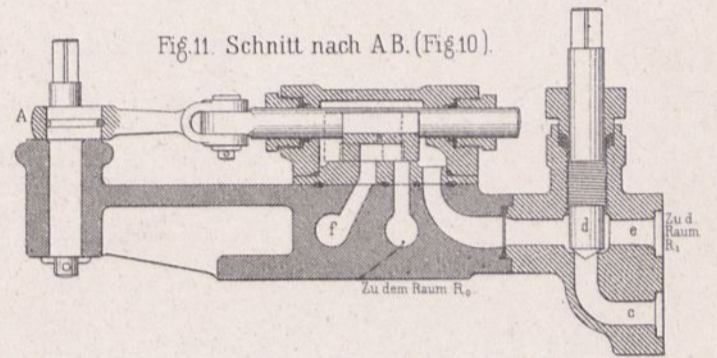

Fig. 5. Grundriss.

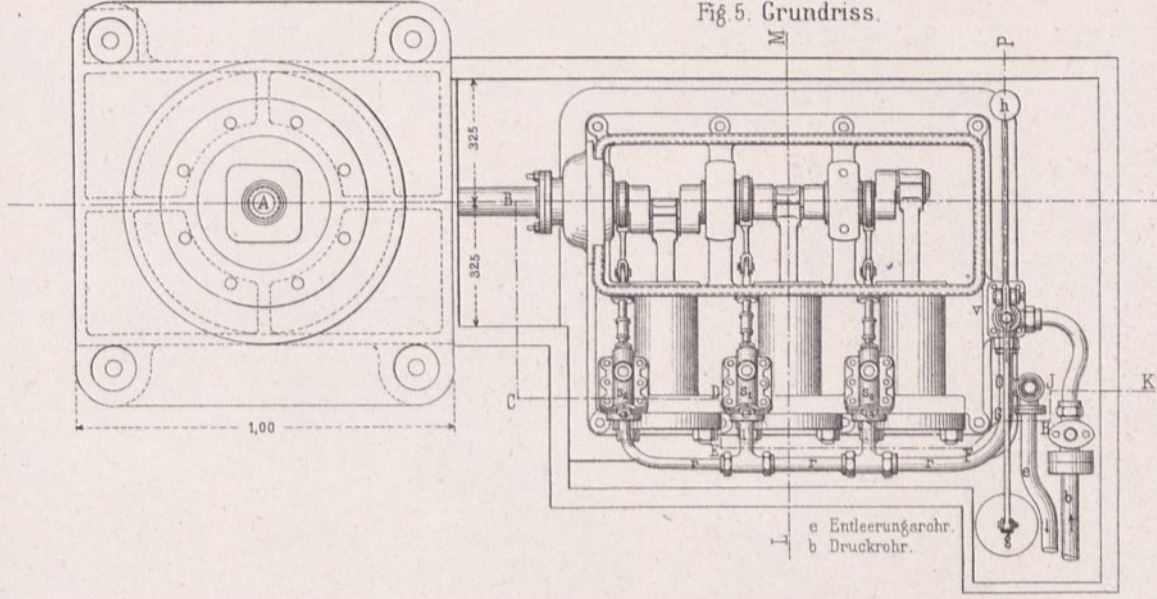

Fig. 9-14. Apparat zum Bewegen der Thore.

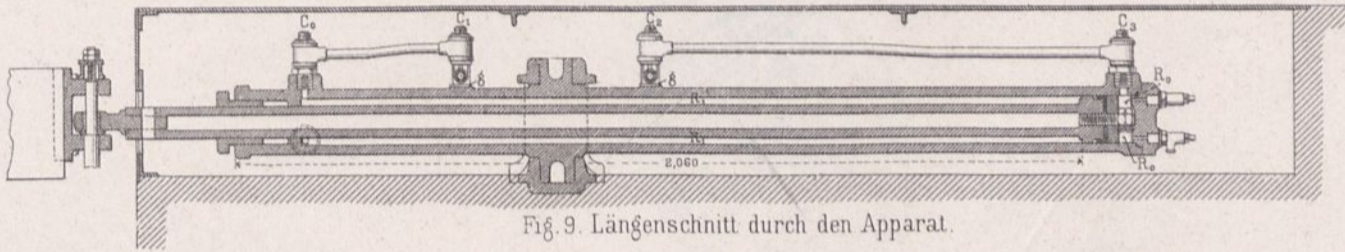

Fig. 9. Längenschnitt durch den Apparat.

Fig. 12. Querschnitt durch den Schieberkasten.



Fig. 10. Grundriss.

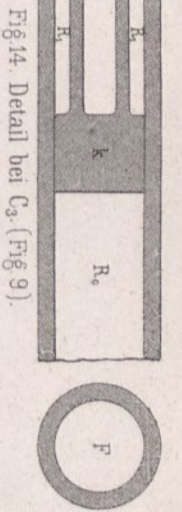
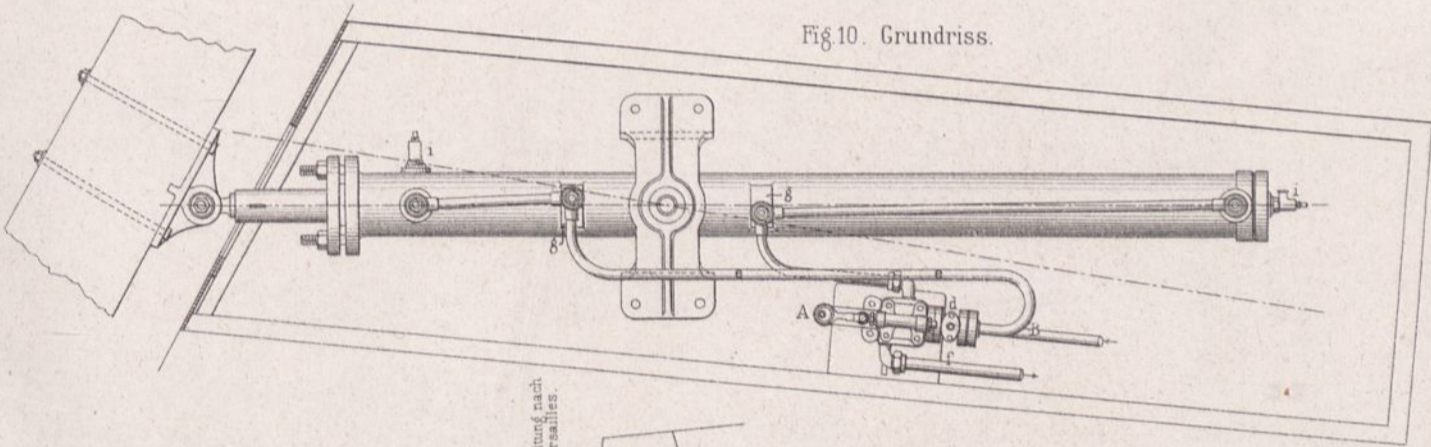

Fig. 14. Detail bei Ca. (Fig. 9).

Fig. 13. Detail bei C. (Fig. 9).

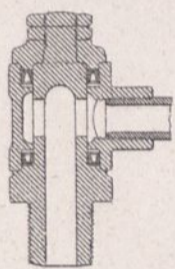
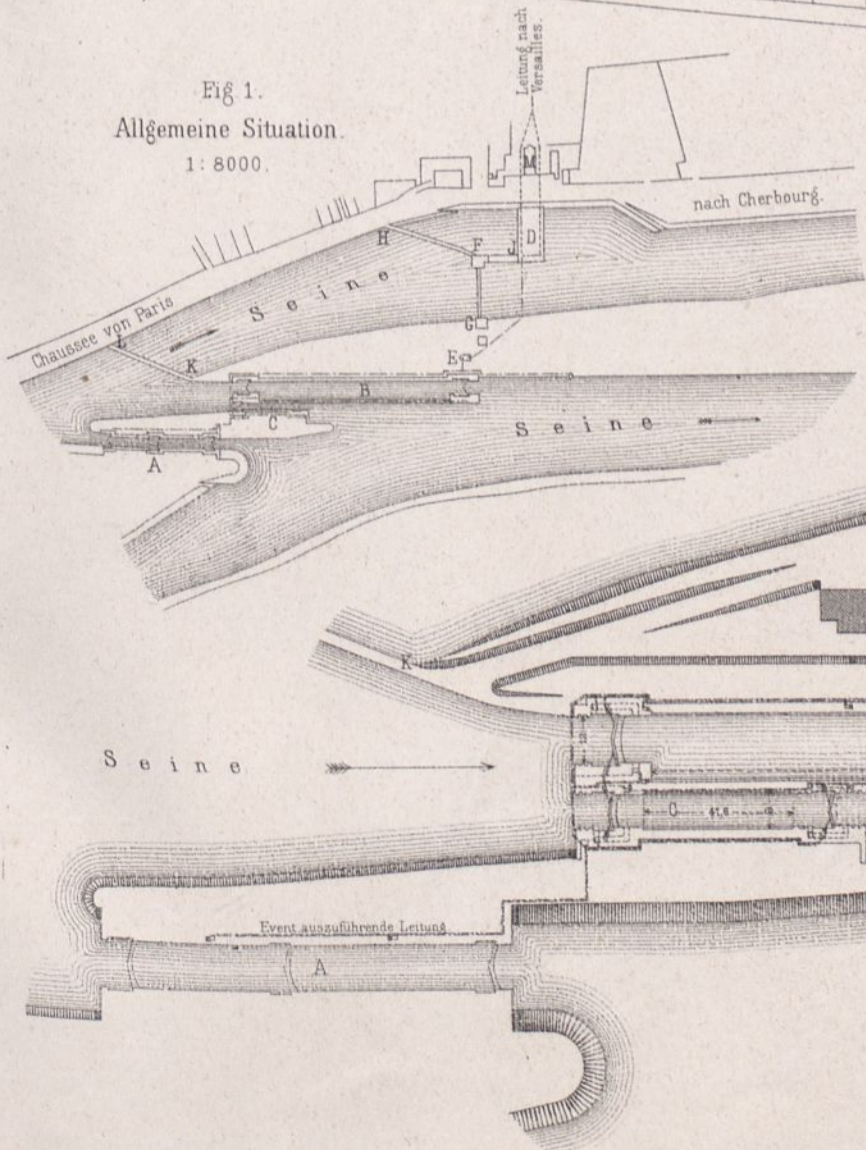
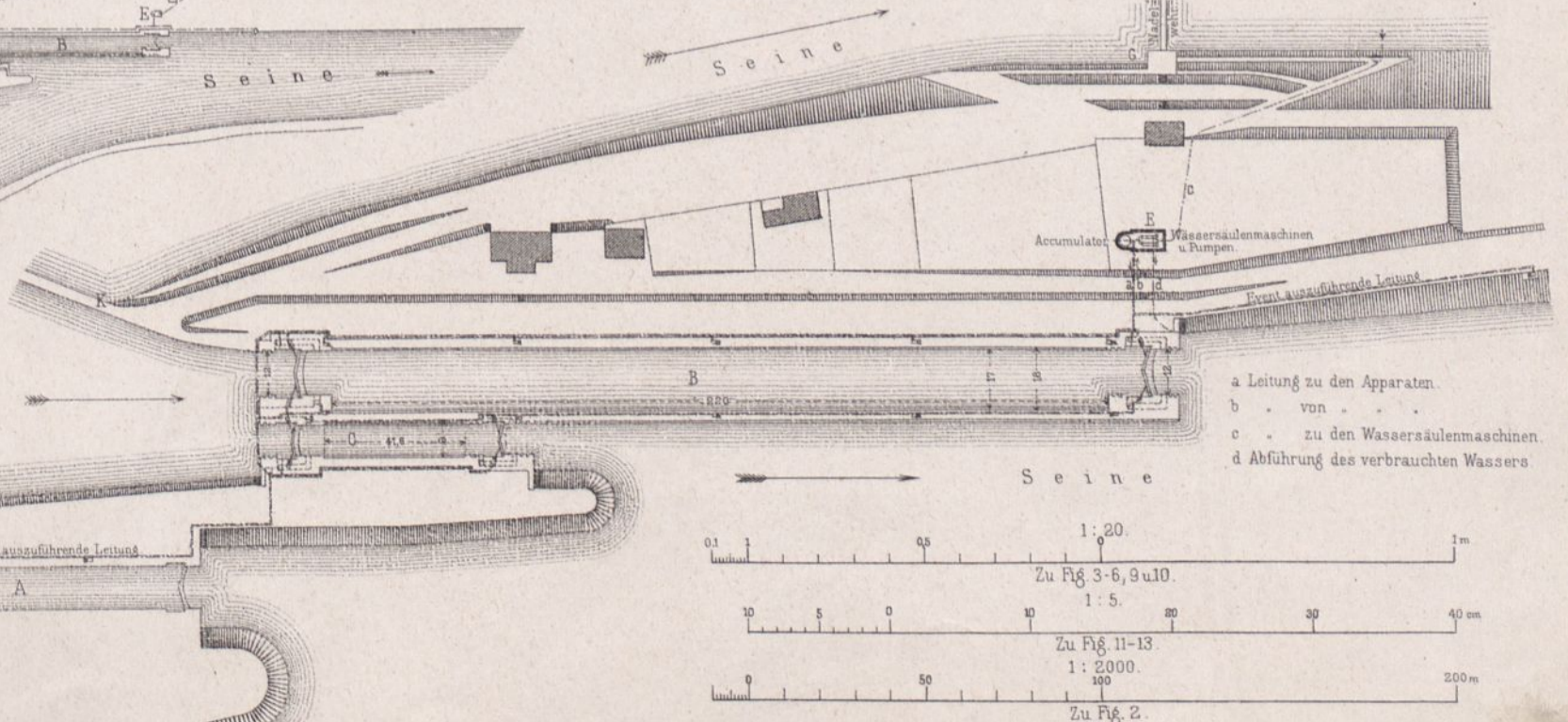

Fig. 1. Allgemeine Situation. 1: 8000.



- A Alte Schleuse. B u. C Neue Schleusen.
- D Altes Maschinenhaus mit 6 Wasserrädern.
- E Neues mit Wassersäulenmaschinen u. Accumulator.
- F J Grundablass. F G Nadelwehr.
- F H Gitter. L K Holzbrücke.
- M Alte, jetzt unbenutzte Dampfmaschine.

Fig. 2. Spezielle Situation der Schleusenanlage. 1: 2000.



Längenprofil.

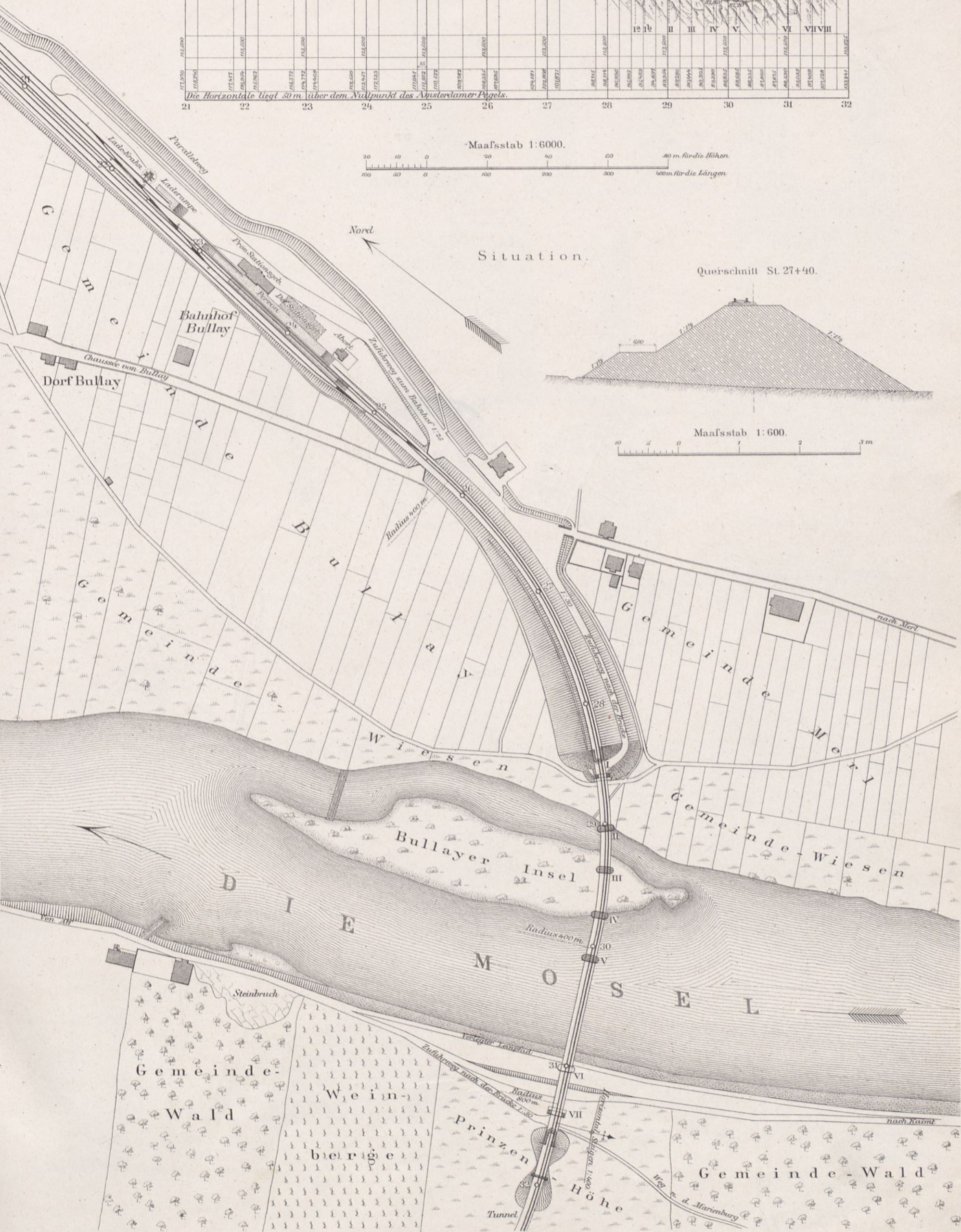
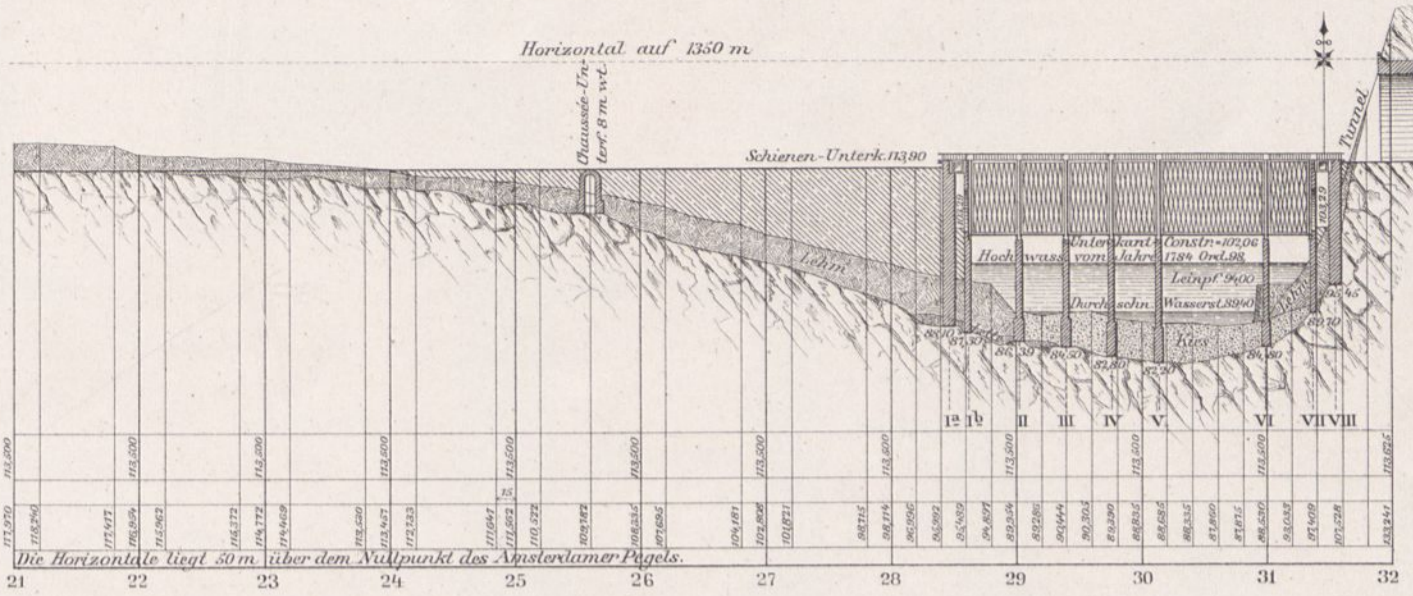

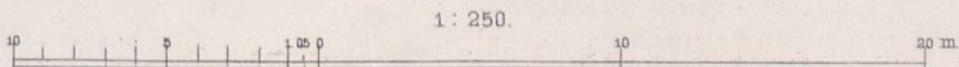
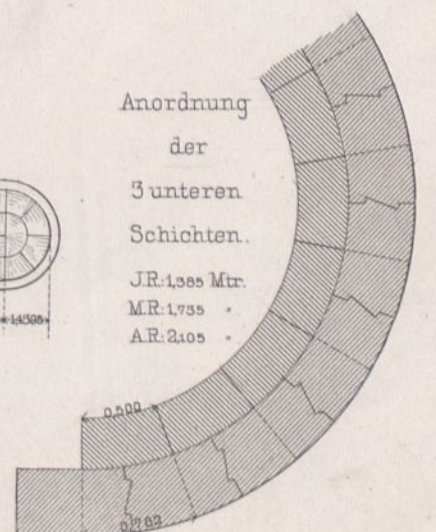
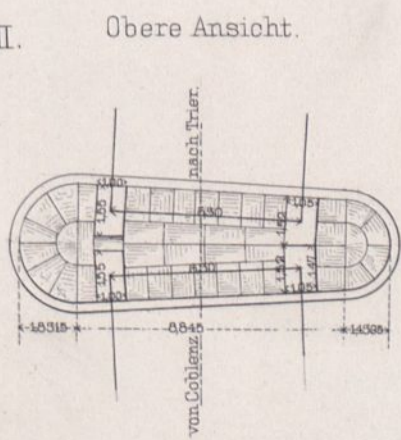
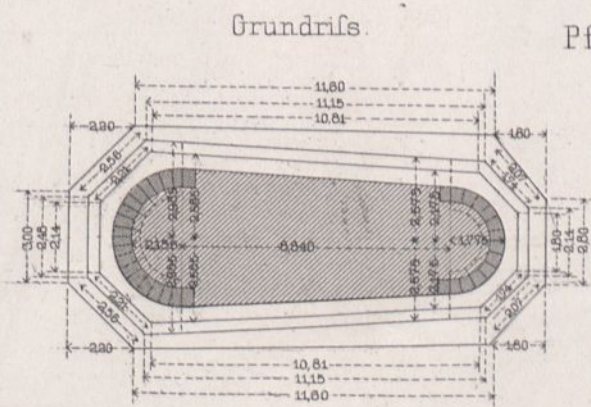
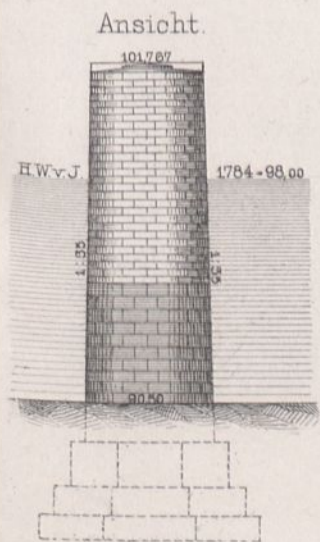
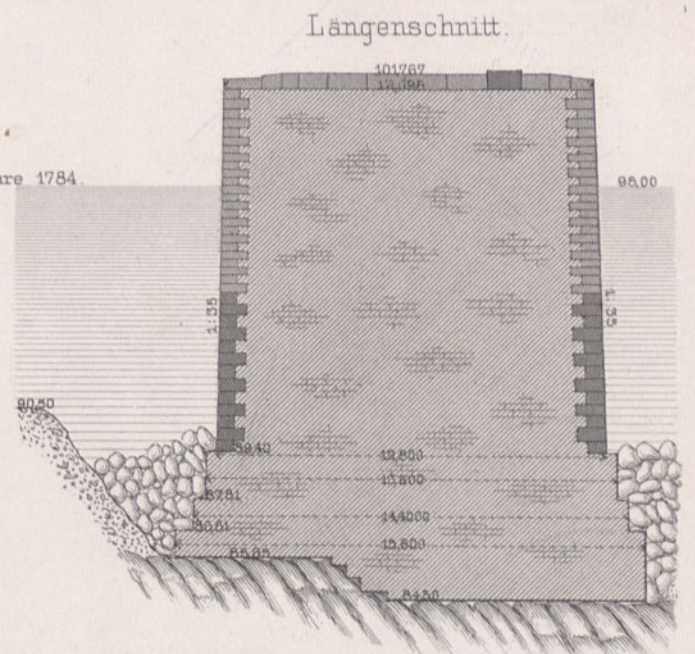
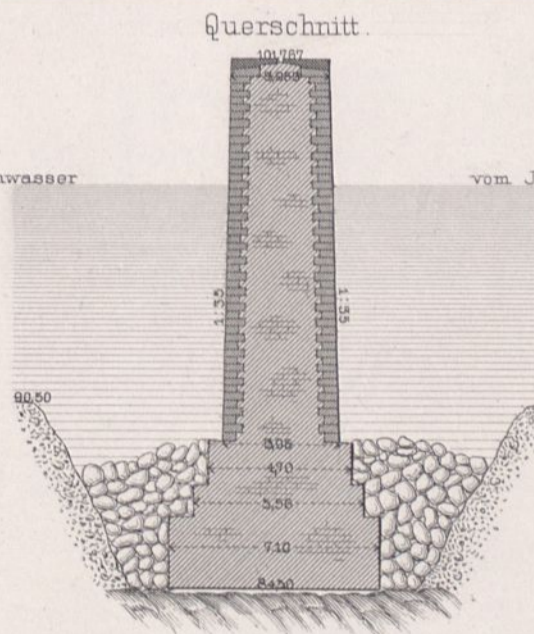
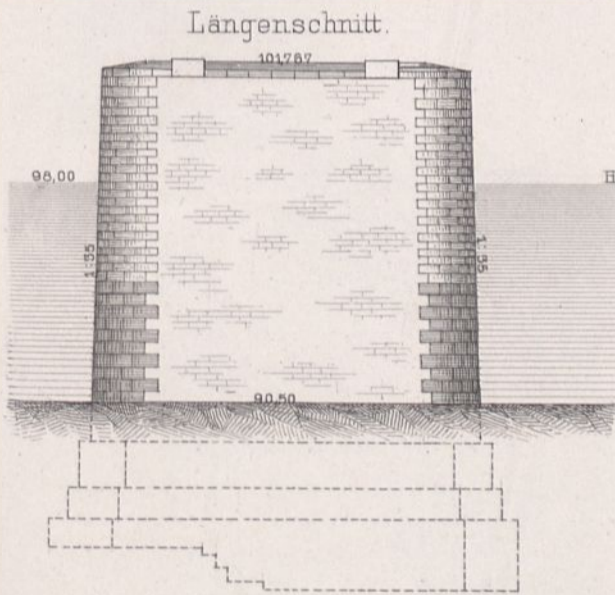
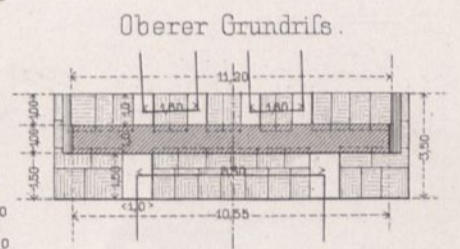
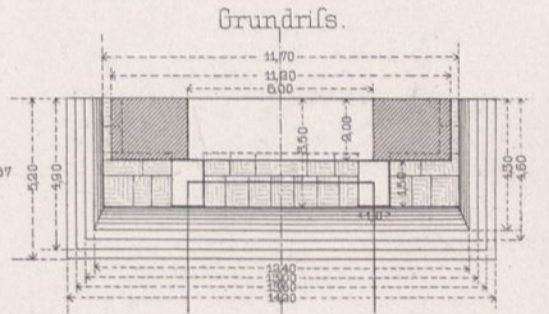
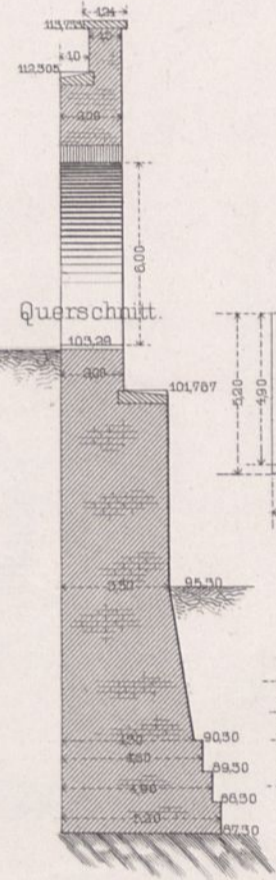
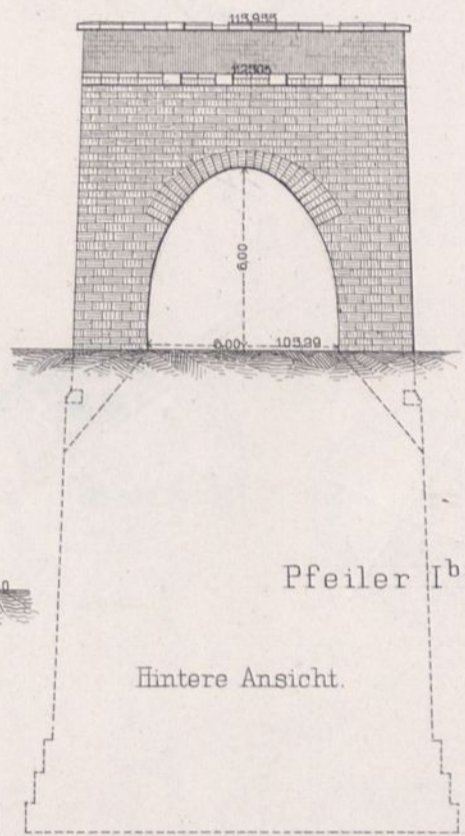
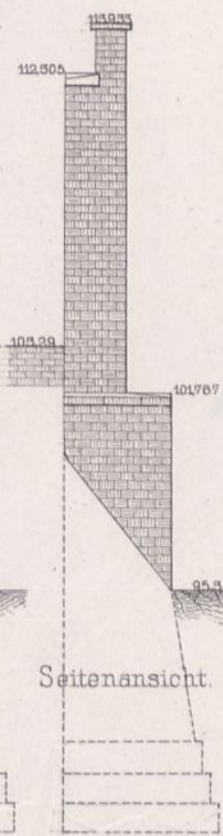
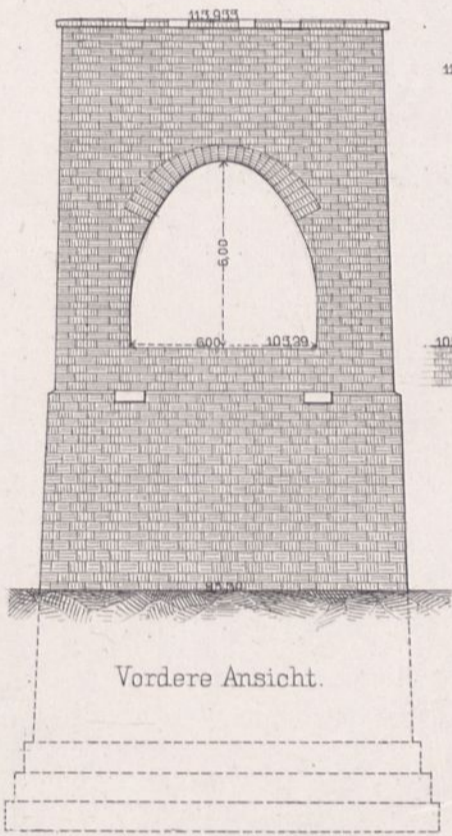
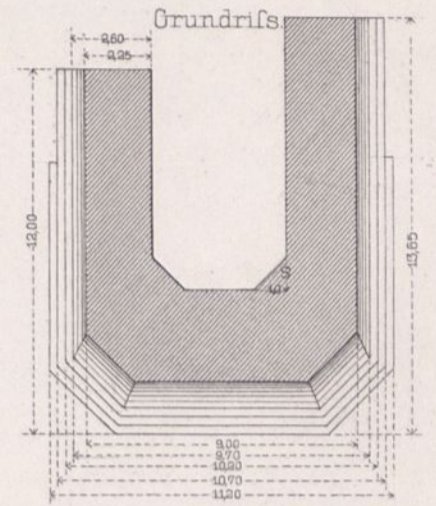
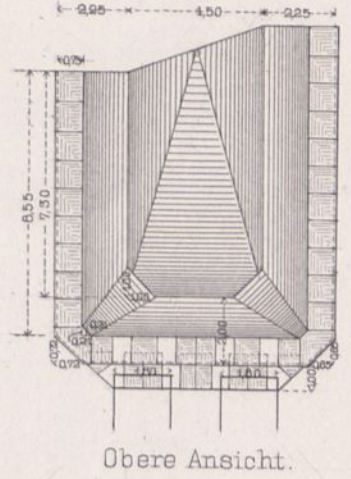
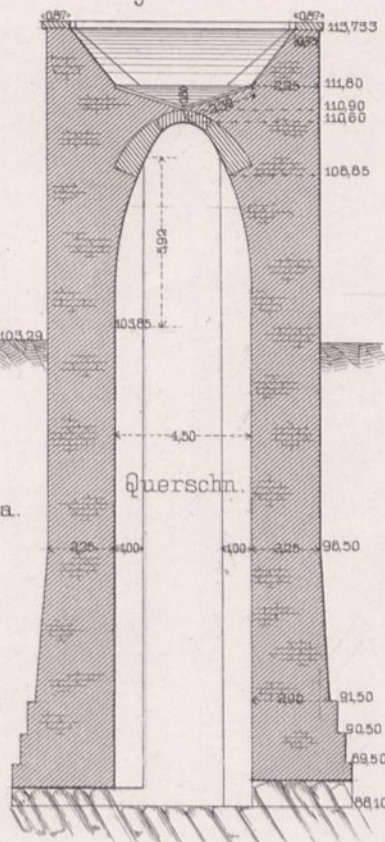
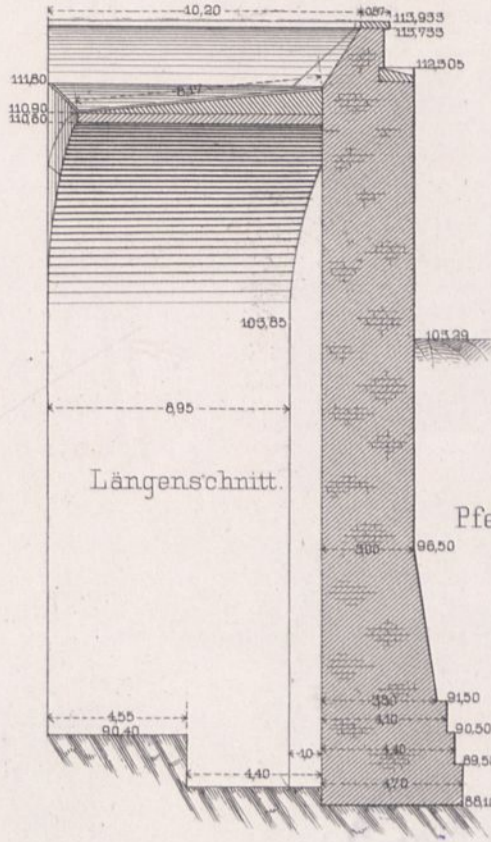
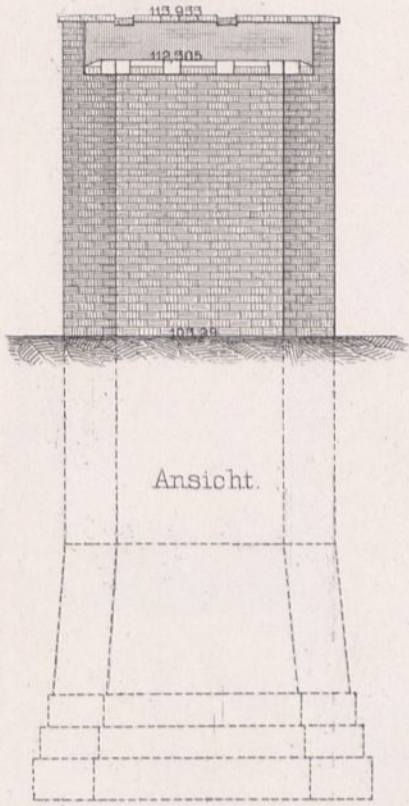

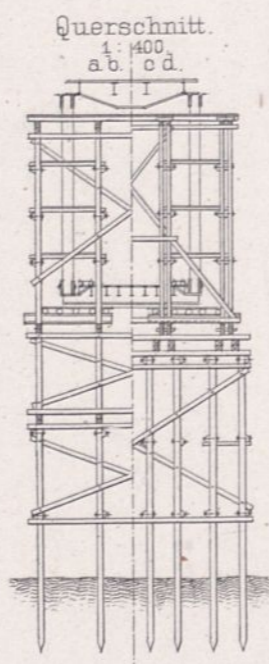
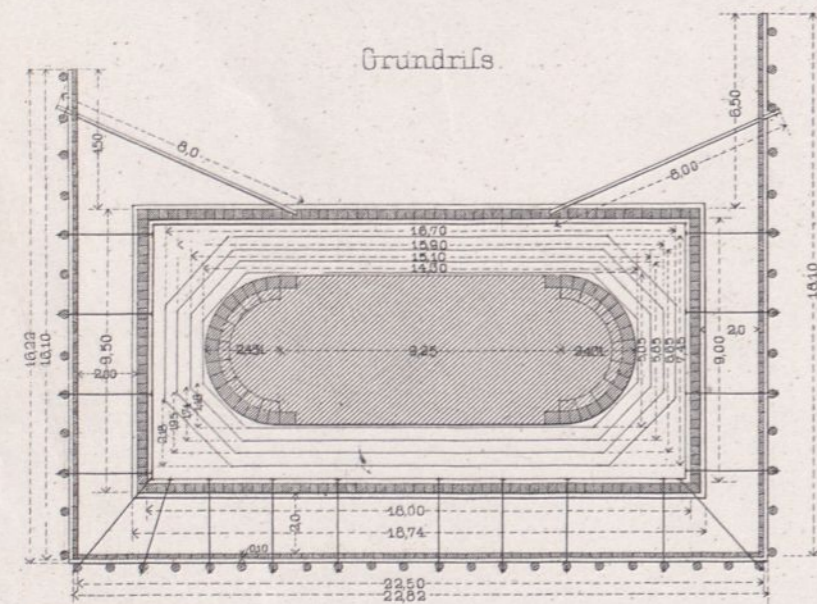
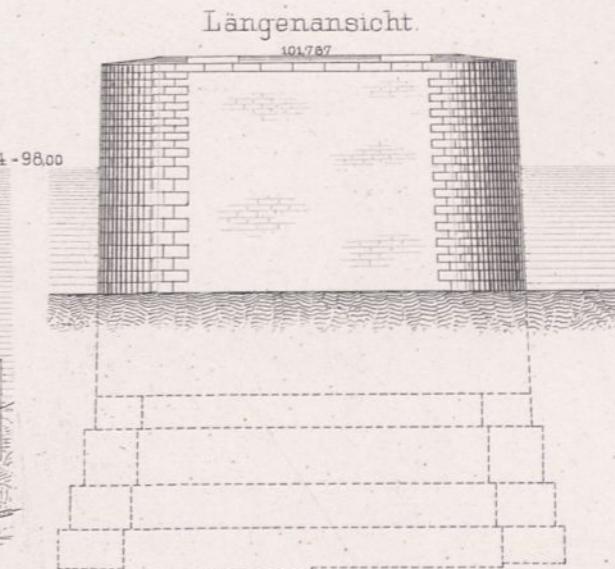
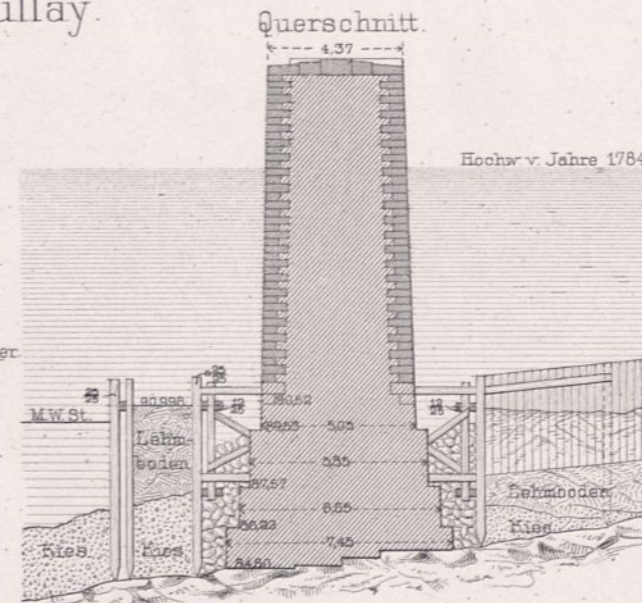
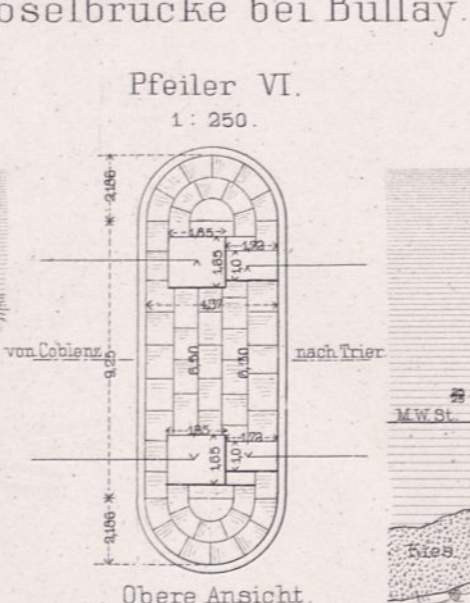
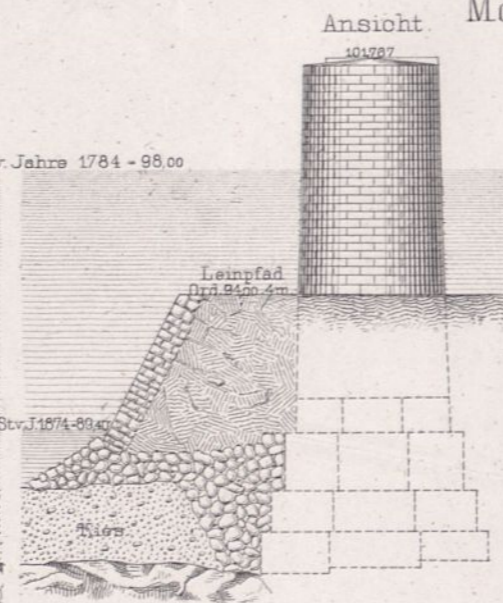
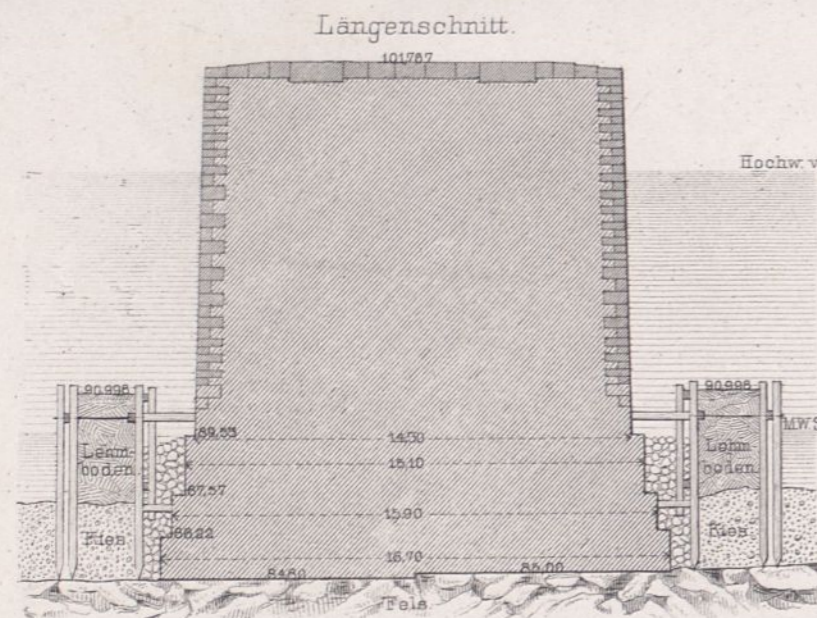

Montagegerüst der grossen Oeffnung.

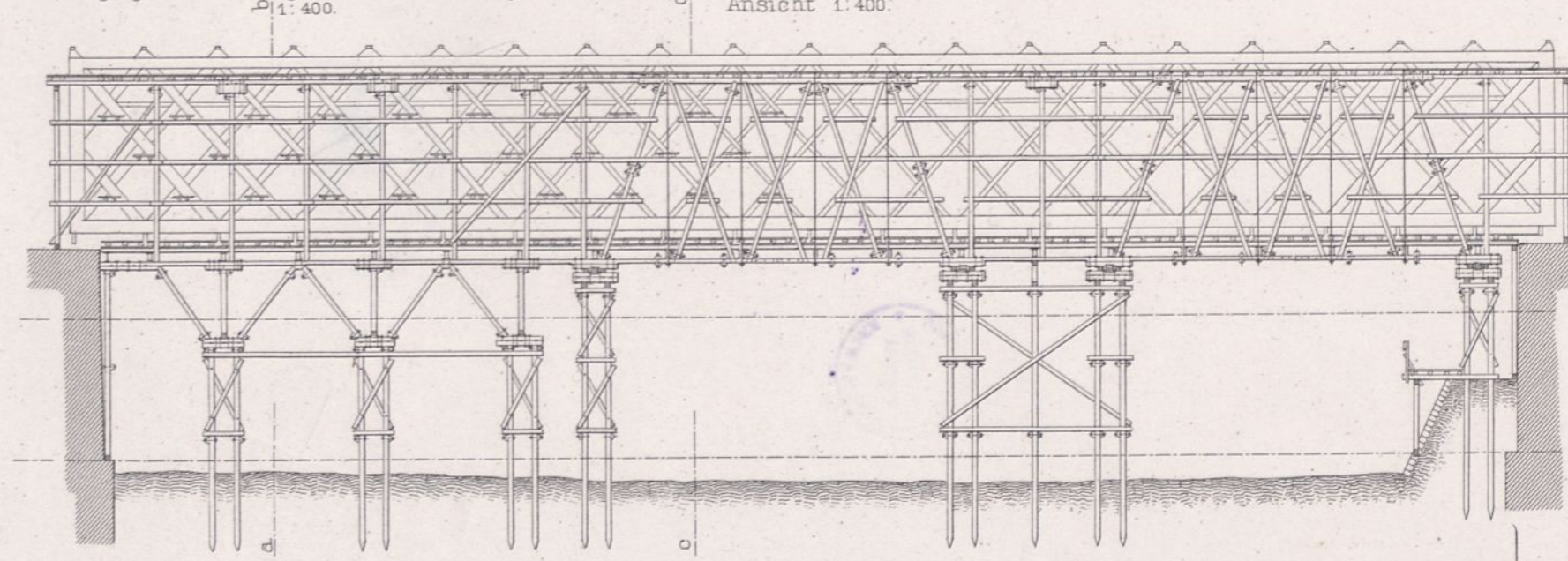

Oberer Knotenp am Trägerende.

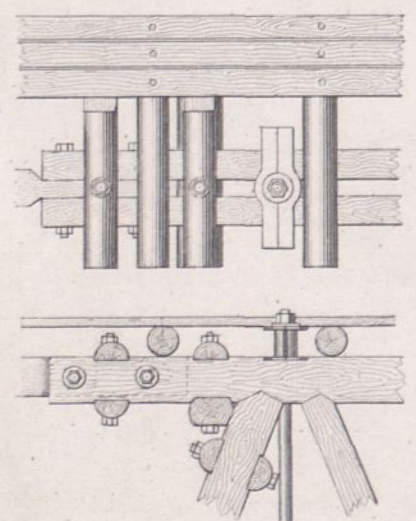

Keil u. Kopfschraubenstellung.

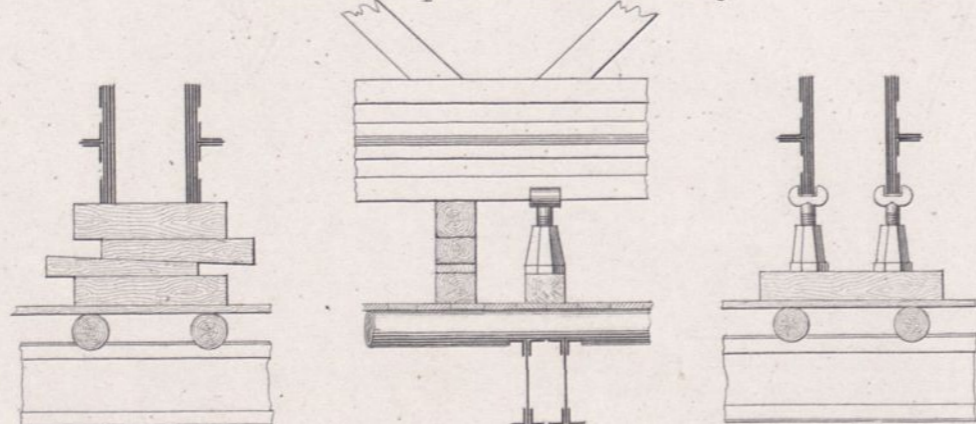

Ansicht u. Schnitt eines unteren Knotenpunktes.

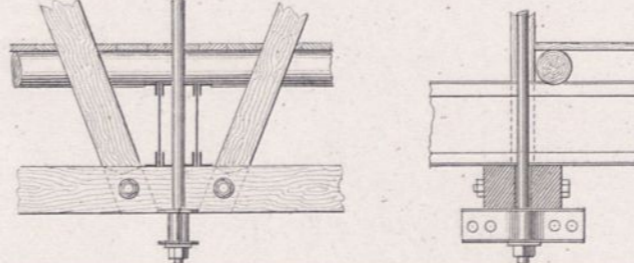

Grundriss 1: 400.

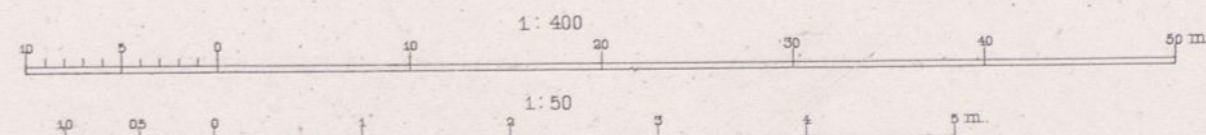
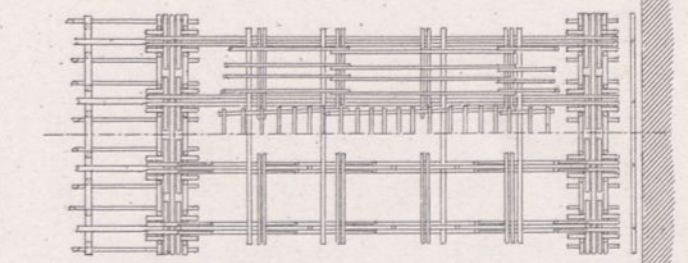

Ansicht.



Grundriss.

1:900.
 10 20 30 40 50 m.

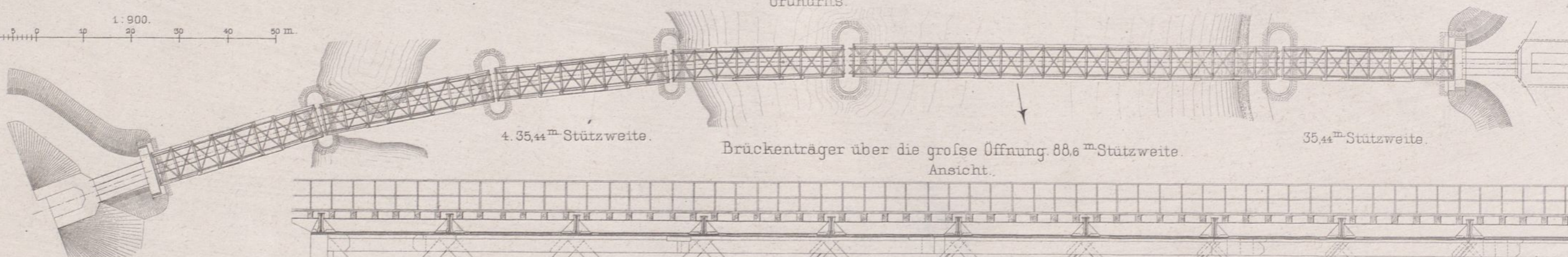

Brückenträger über die große Öffnung 88,6^m Stützweite.
Ansicht.

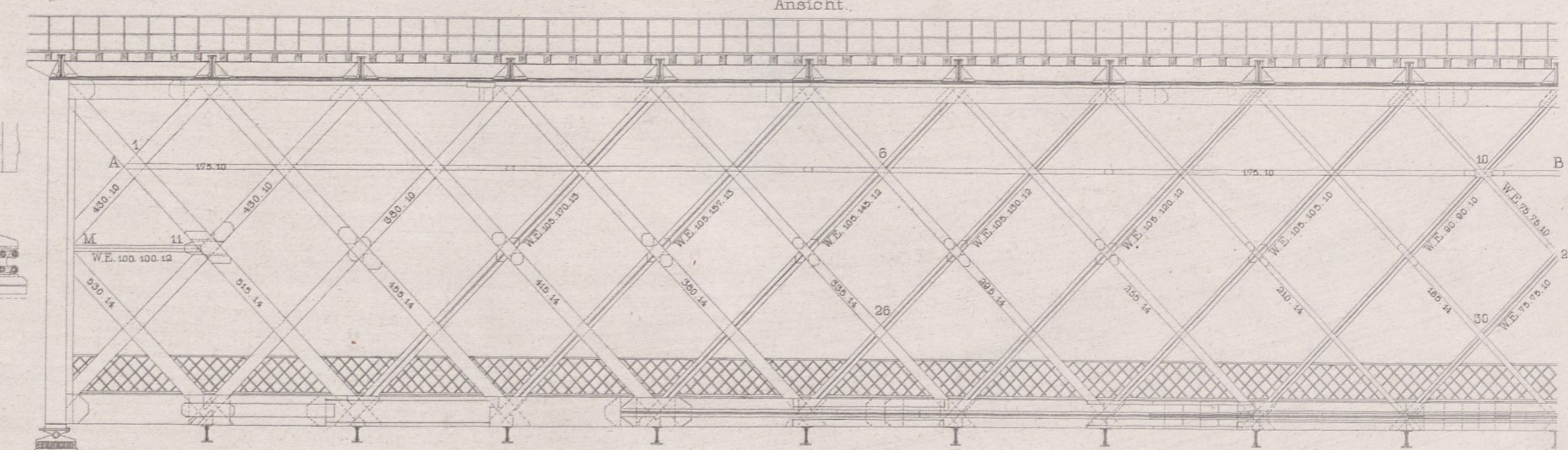
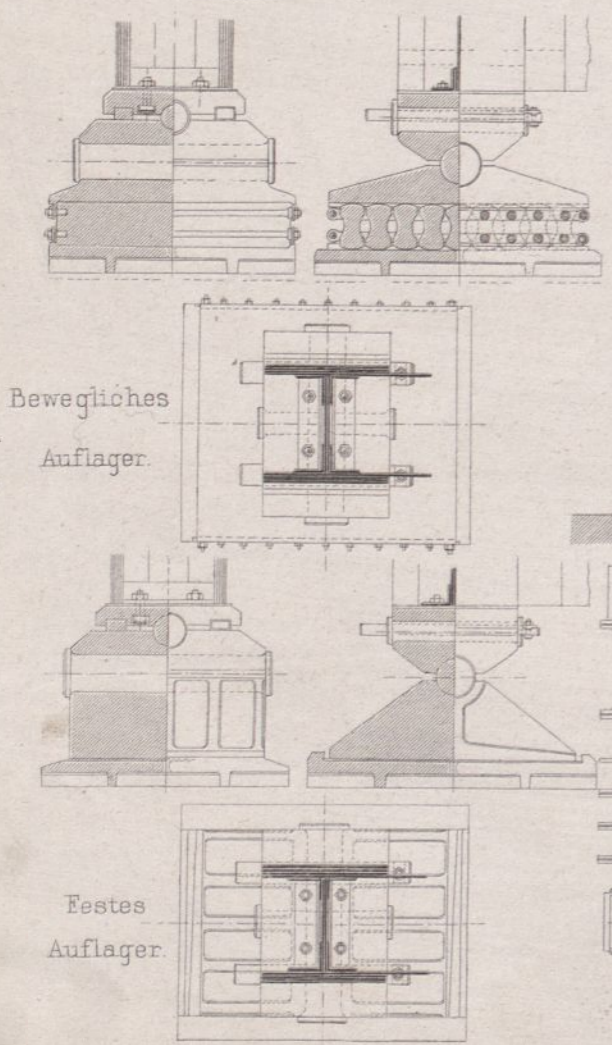

Obere Ansicht mit Fahrbahn.

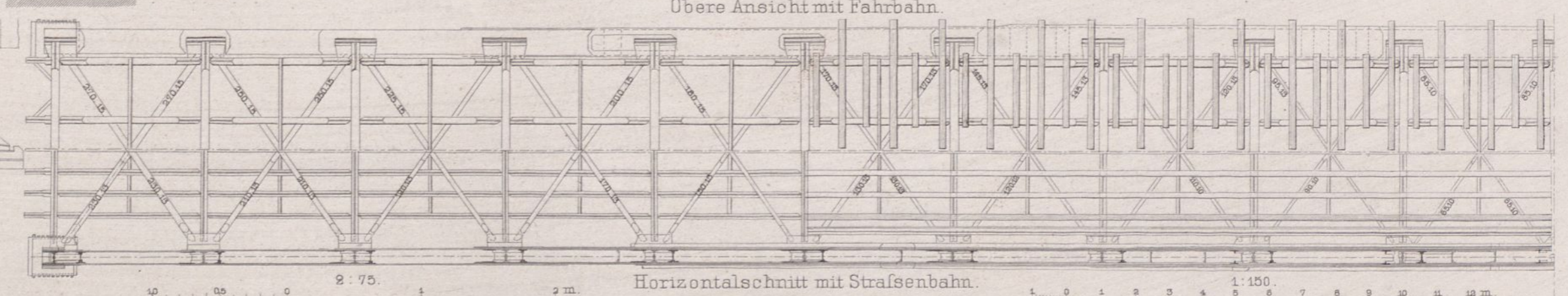

Horizontalschnitt mit Straßenbahn.

10 05 0 2:75 2 m.

1:150.
 1 2 3 4 5 6 7 8 9 10 11 12 m.

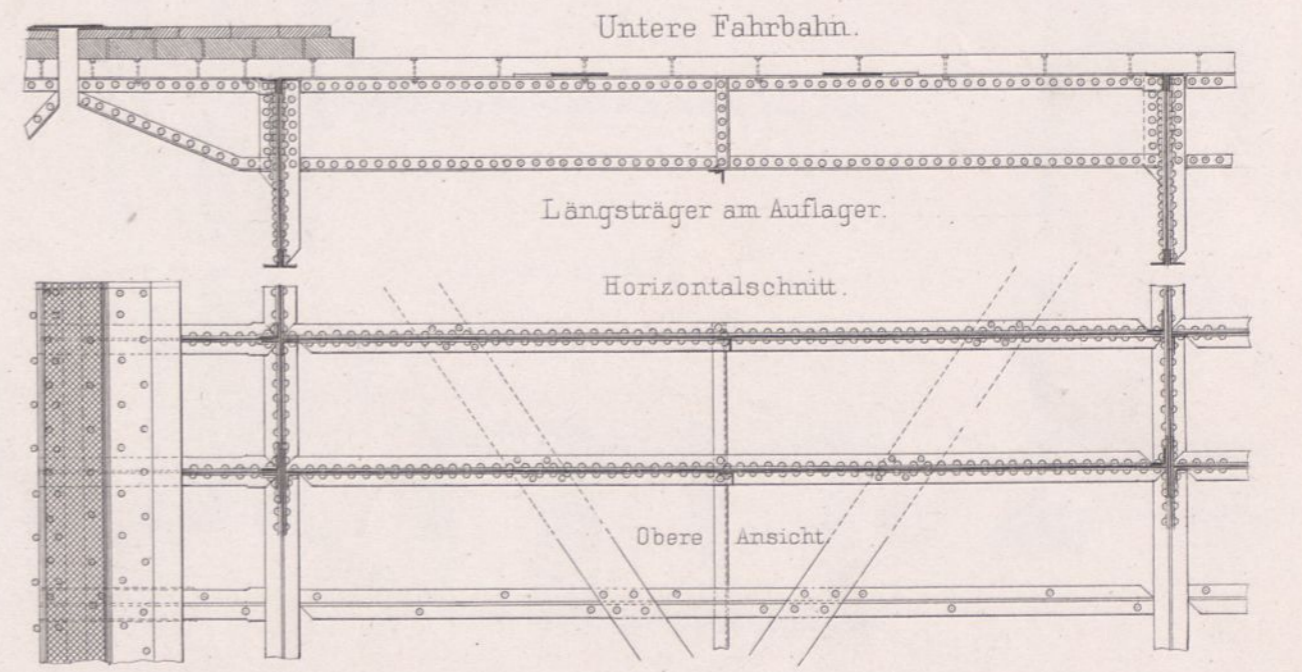
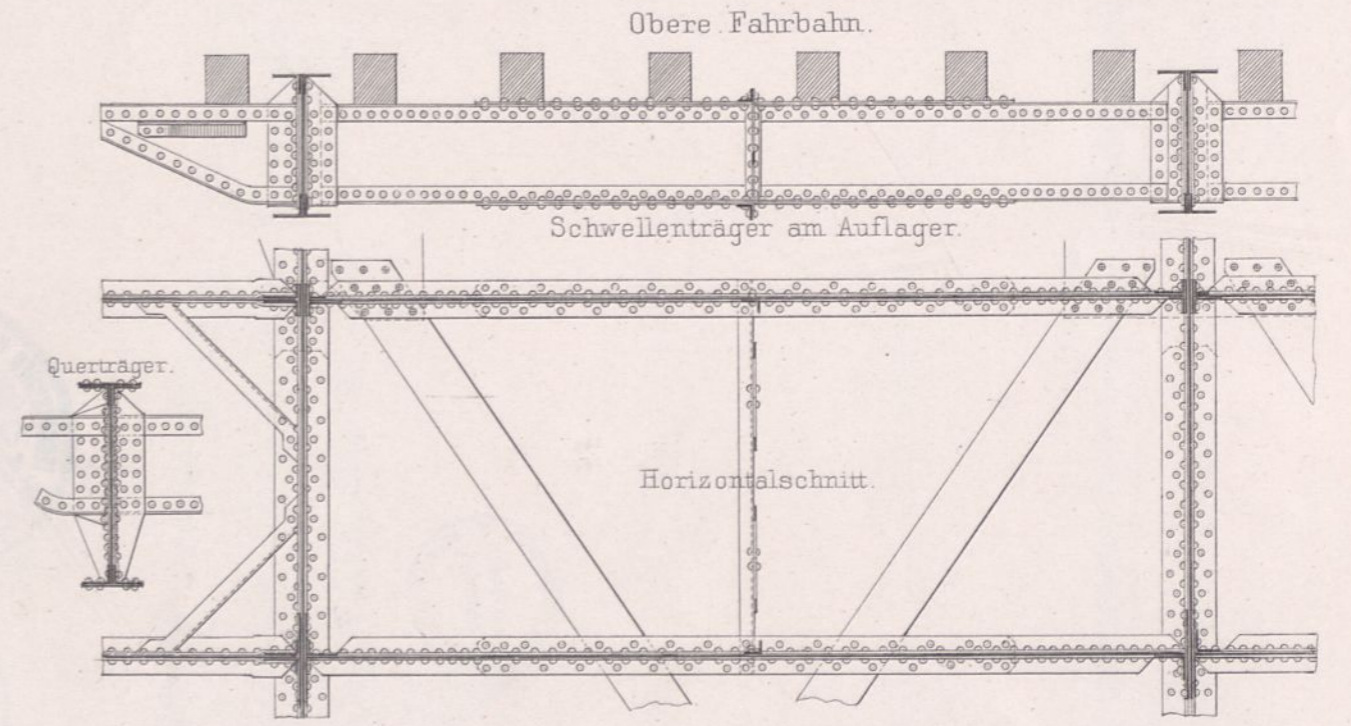
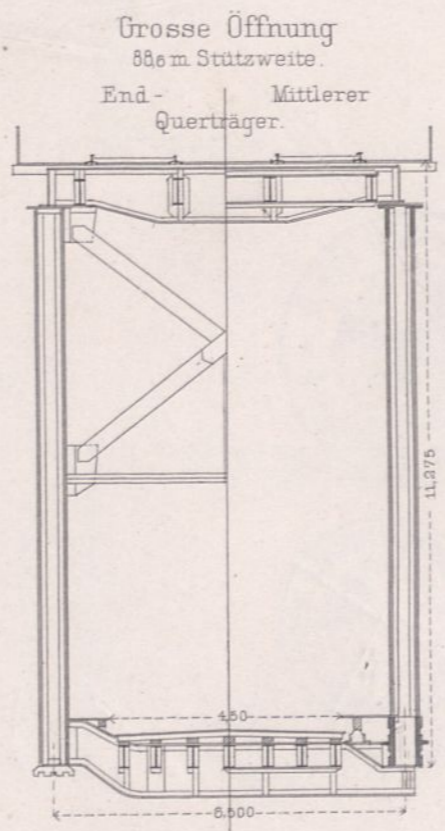
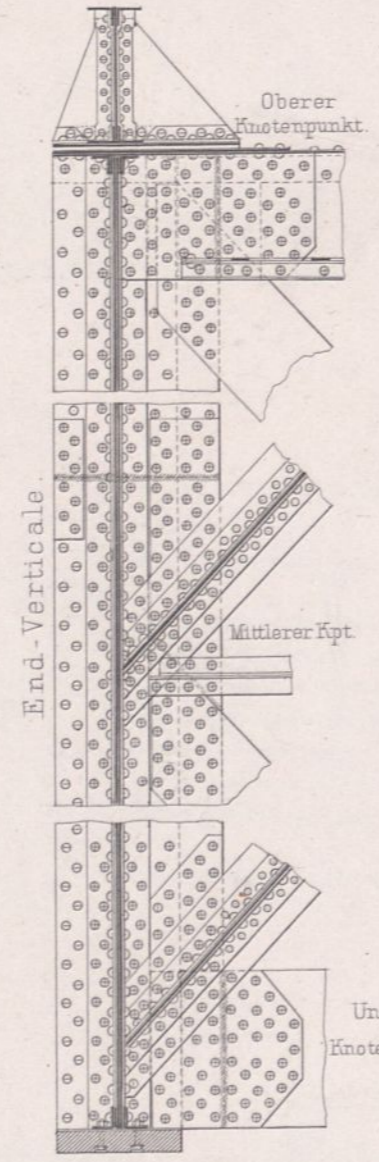
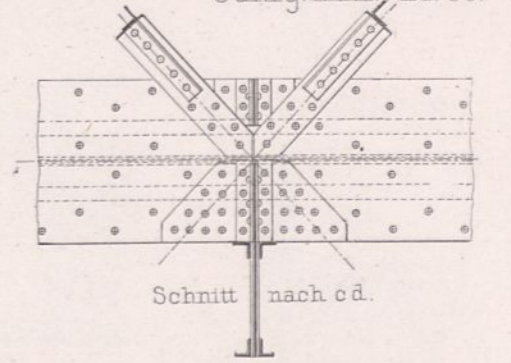
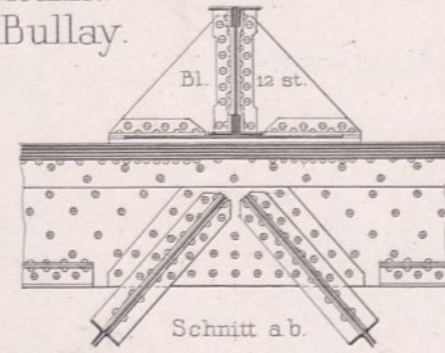
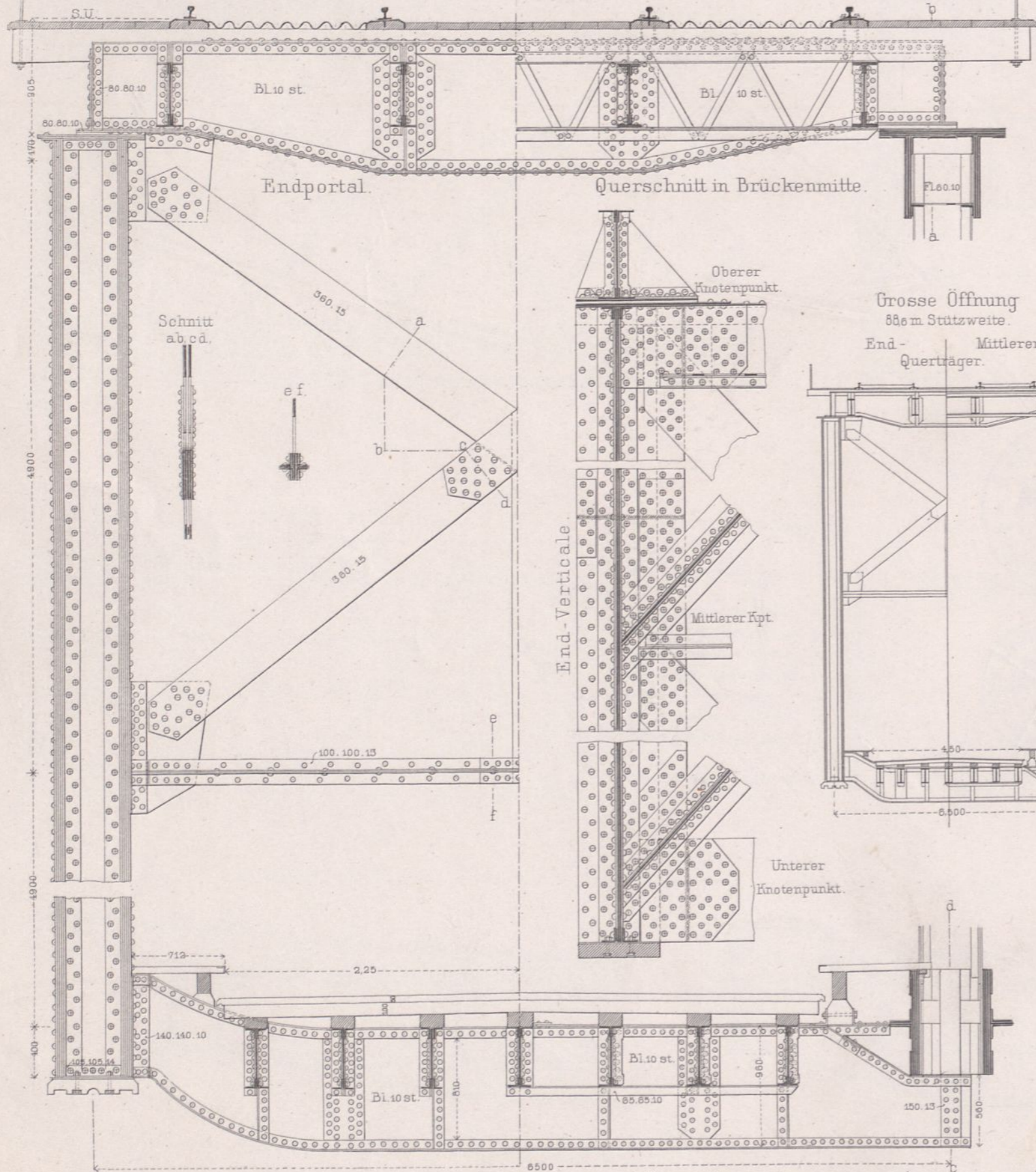

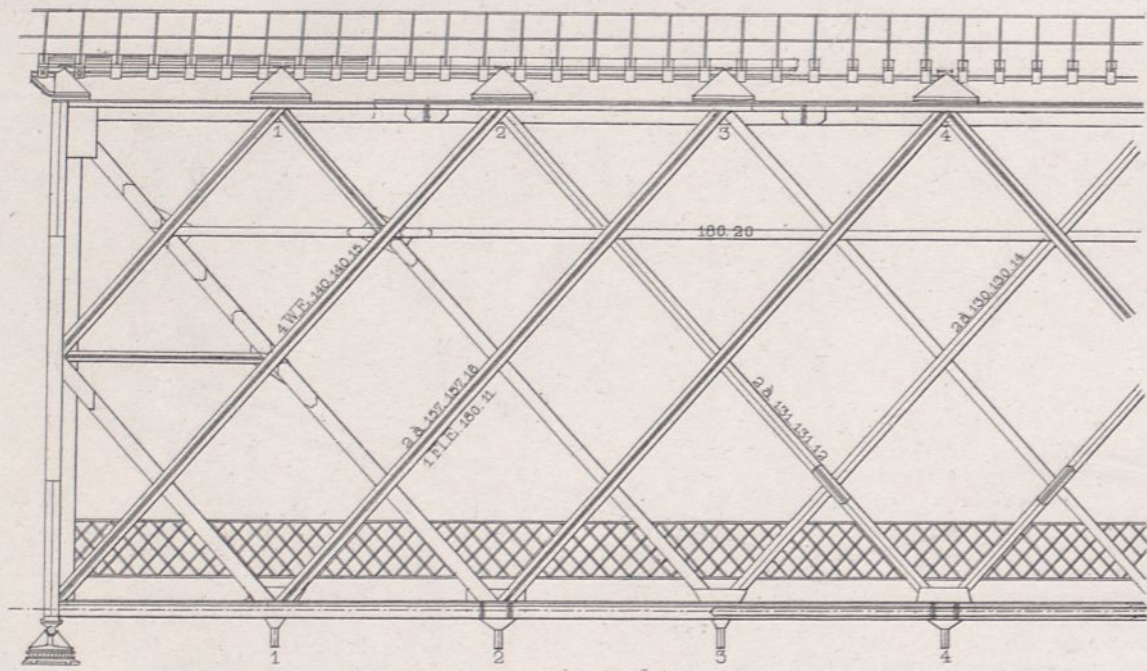

Ansicht.

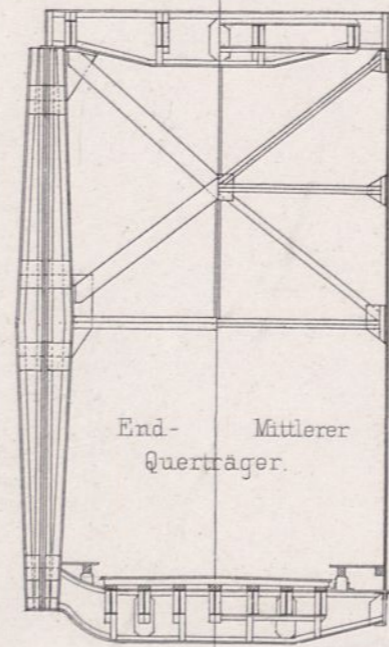

End- Mittlerer Querträger.

Kleine Oeffnung.
354 m Stützweite.

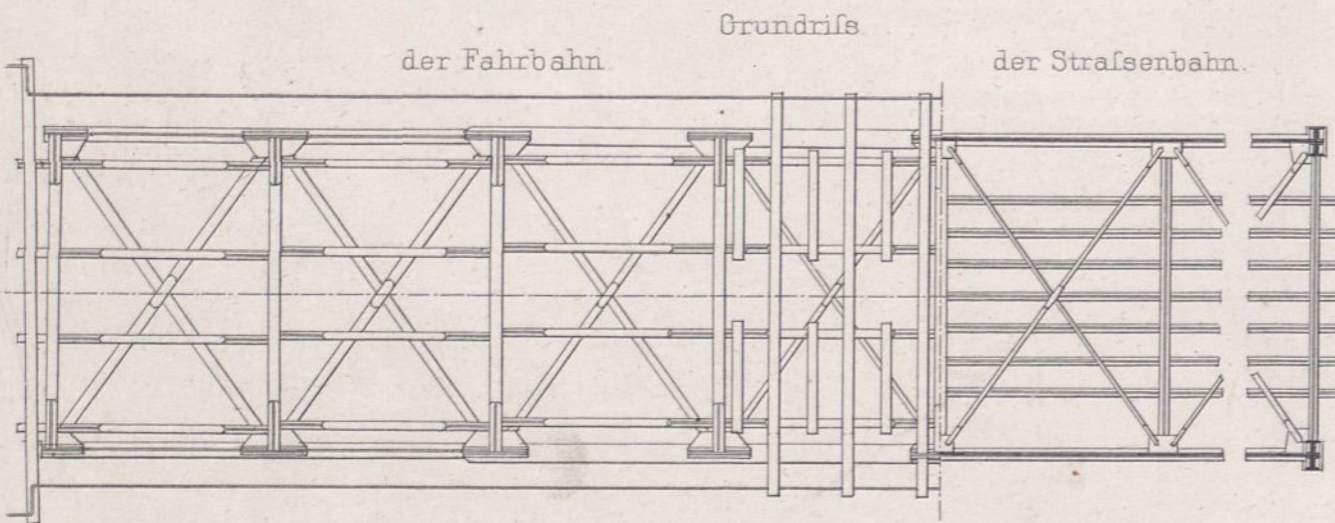

der Fahrbahn.

Grundriss

der Straßebahn.

Schienencompensation.

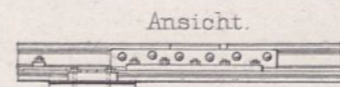

Ansicht.

Schnitt a b.



Grundriss.

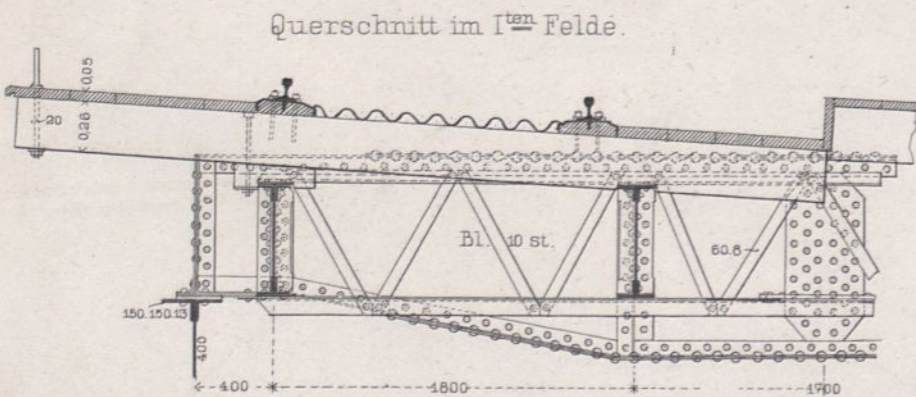
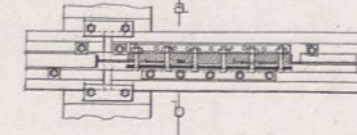

Querschnitt im 1^{ten} Felde.

Bl. 10 st.

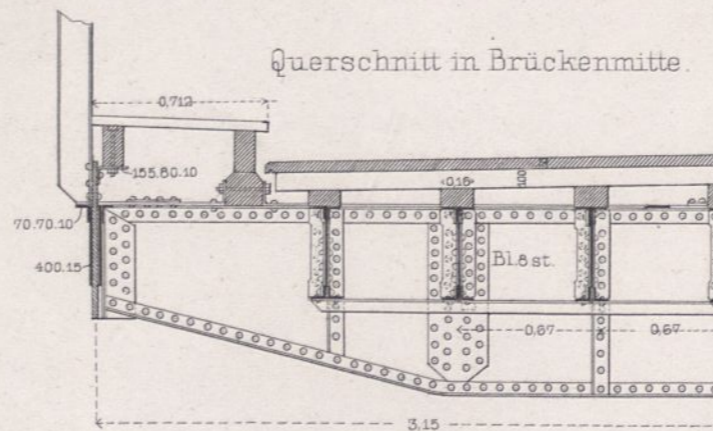

Querschnitt in Brückenmitte.

Bl. 8 st.

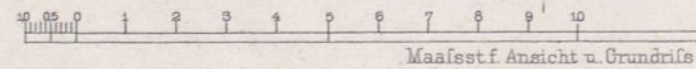

Maassst. f. Ansicht u. Grundriss.

Ernst & Korn. Berlin.

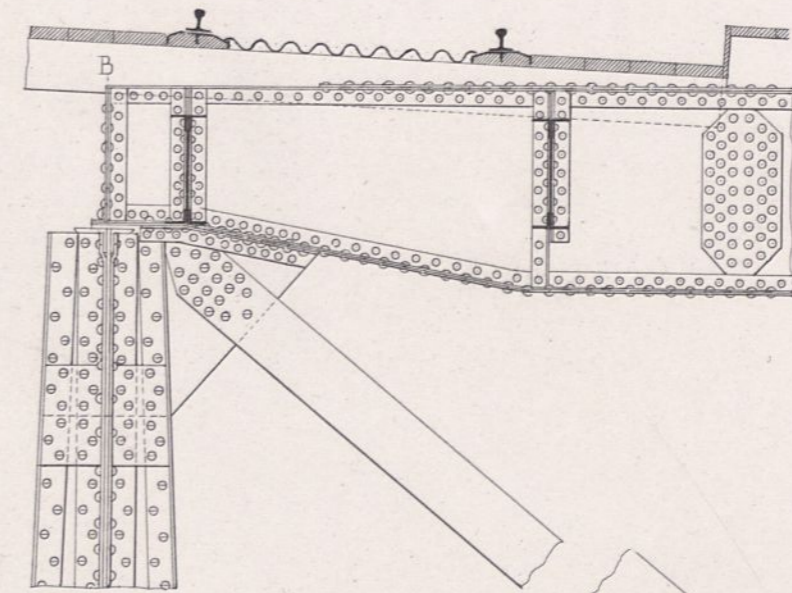

Verticalschnitt A.B.

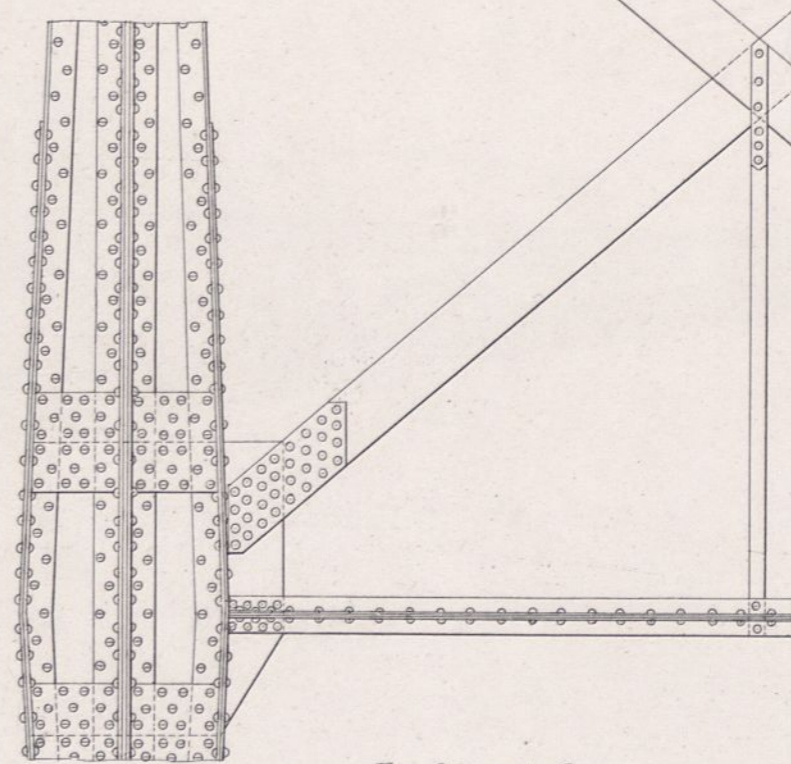
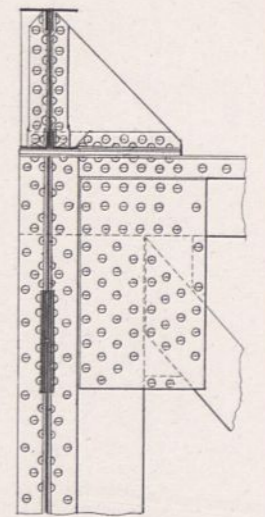

Endportal.

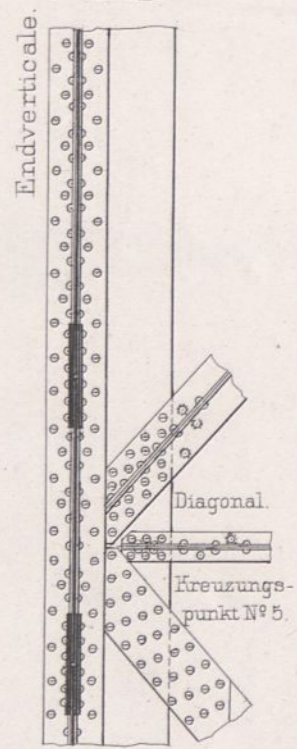

Endverticale.

Diagonal.

Kreuzungs-
punkt N^o 5.

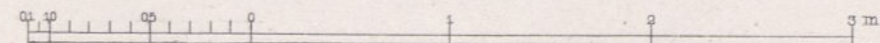

3 m.



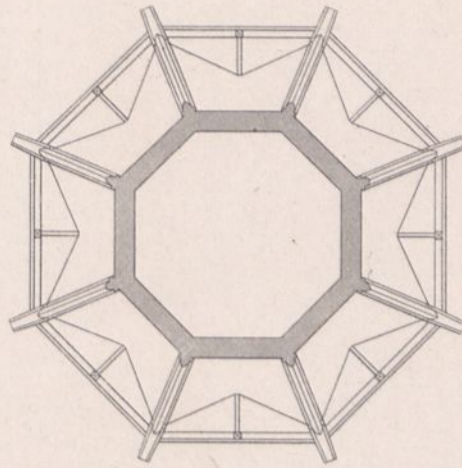
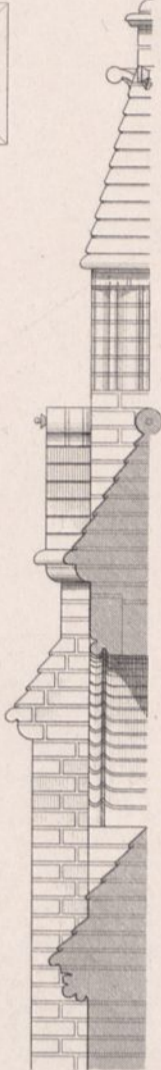
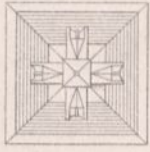
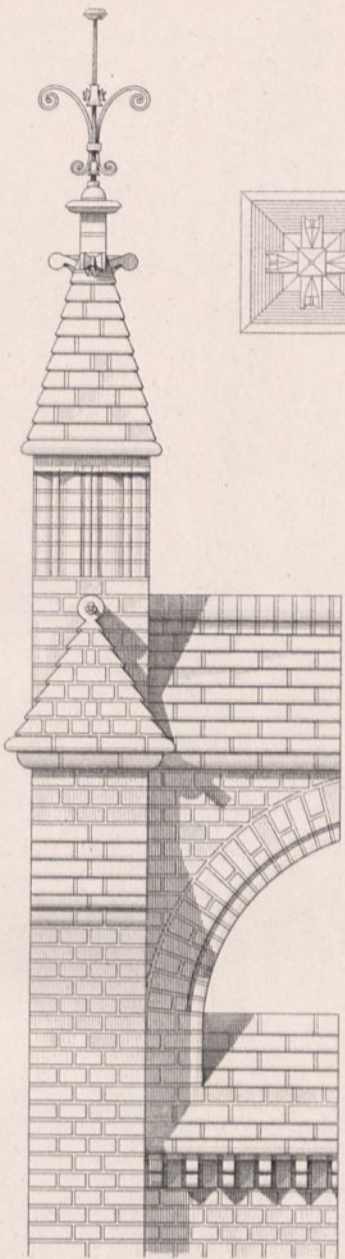

Grundriss G H.

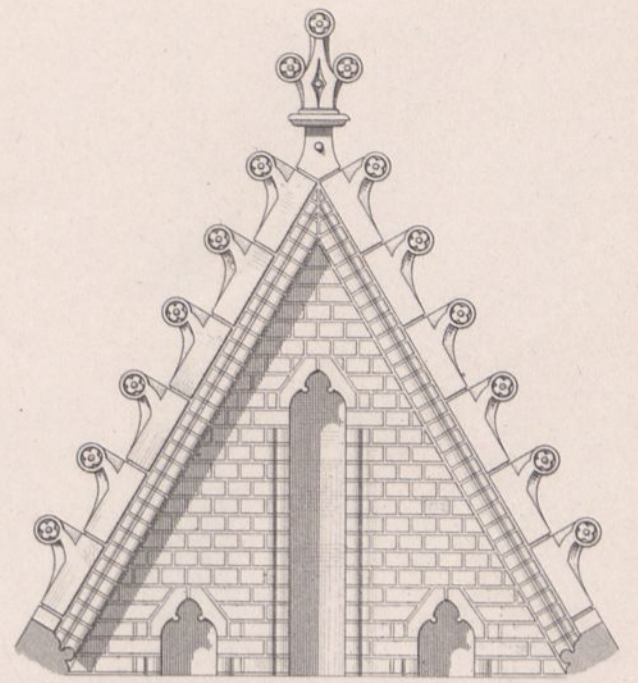

Giebel am Helm.

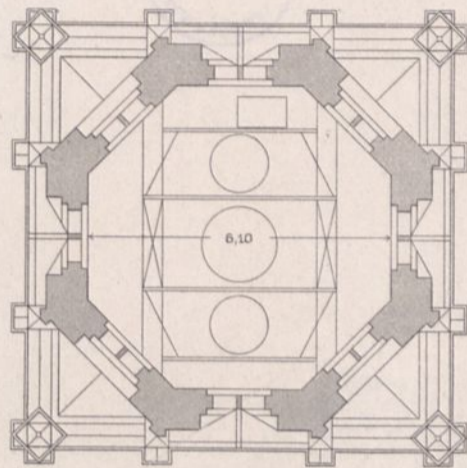

Grundriss E F.

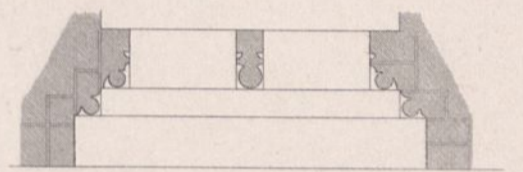
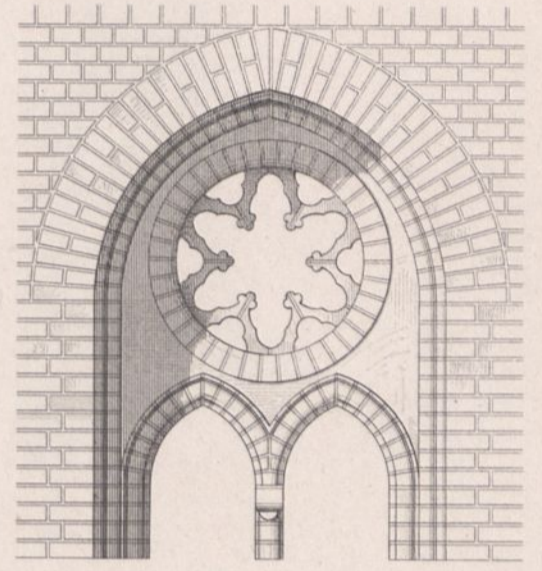

Schallöffnung.

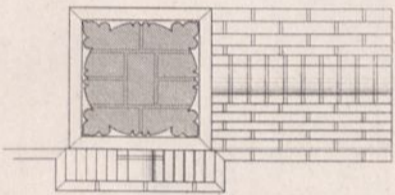

Fiale.

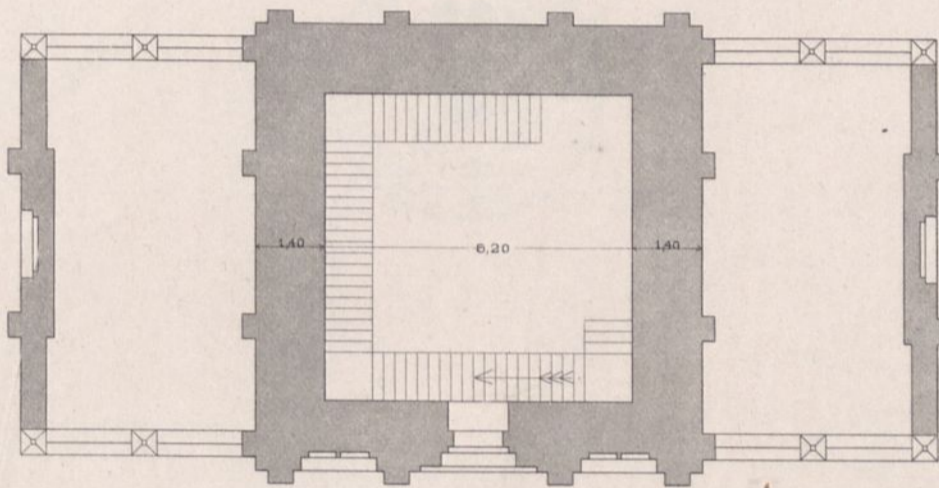

Grundriss C D.

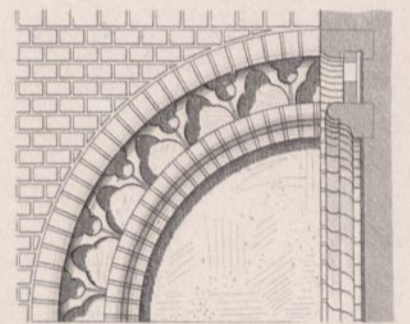

Uhrumrahmung.

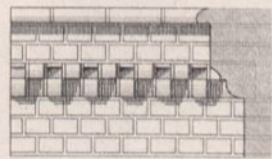

Gesims u. d. Helm.

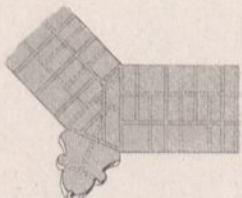

Helmrippe.

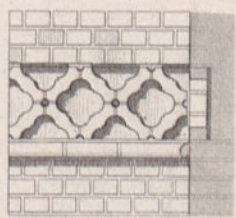

Fries am Thurmquadrat.



Giebelrose.

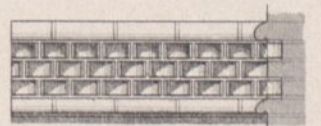

Zahnschnitt am Helm.

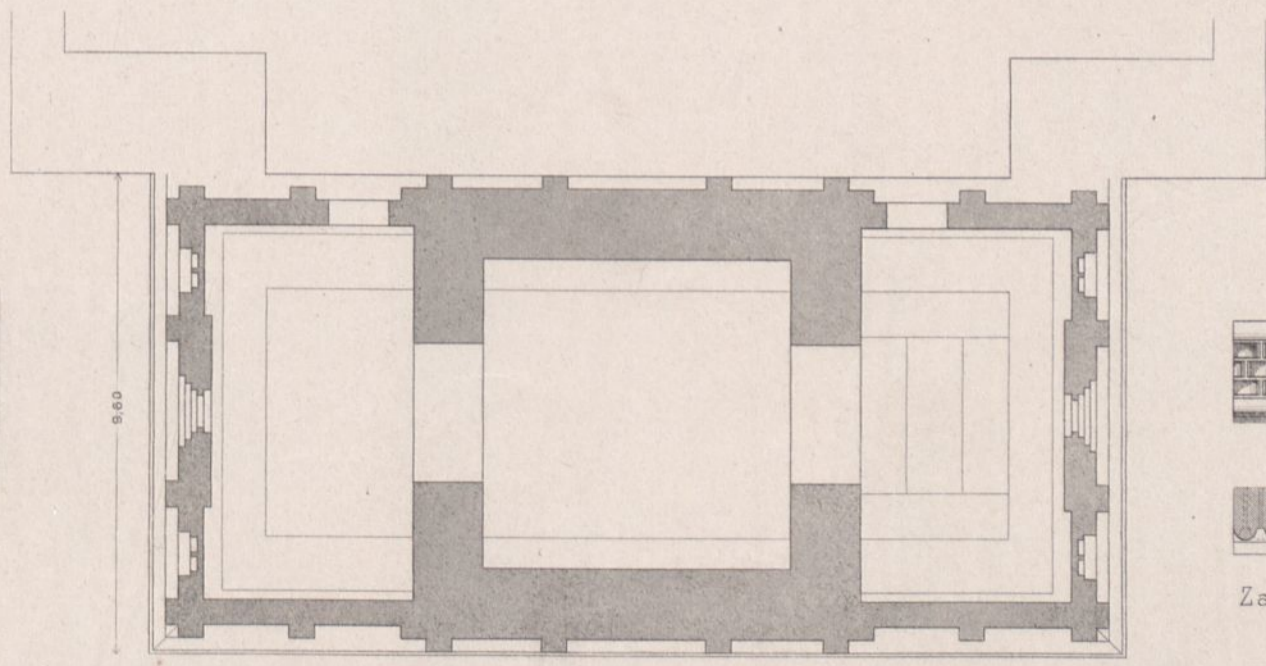

Grundriss A B. (Bl. 42).

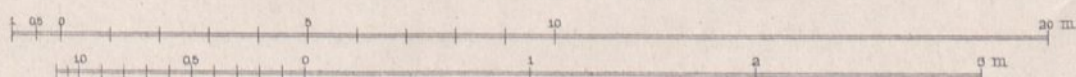

F. Adler entw.

Atlr. Gebr. Ritter u. Riegel.

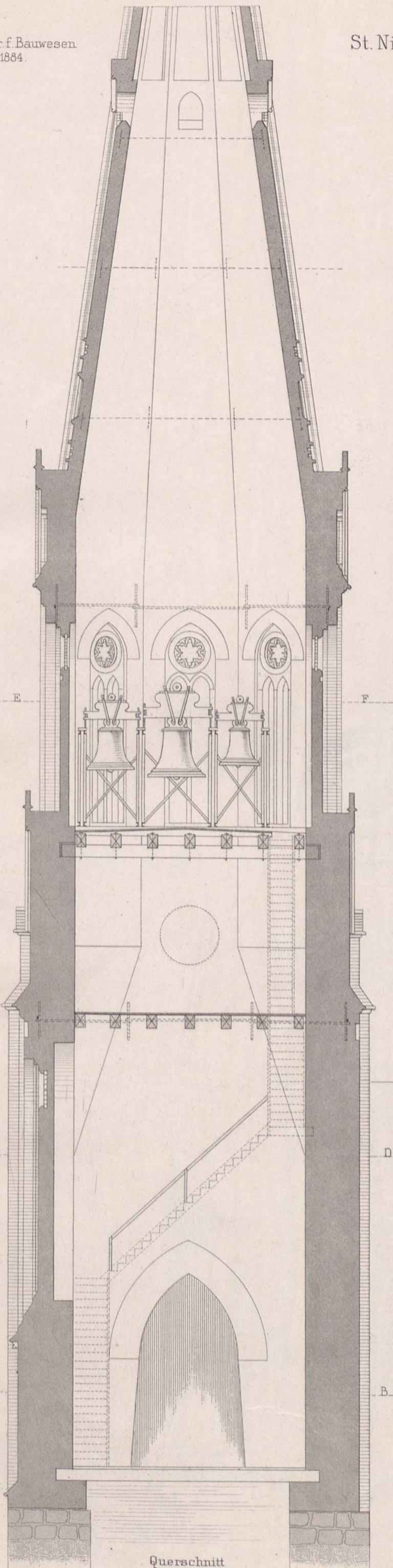

Querschnitt

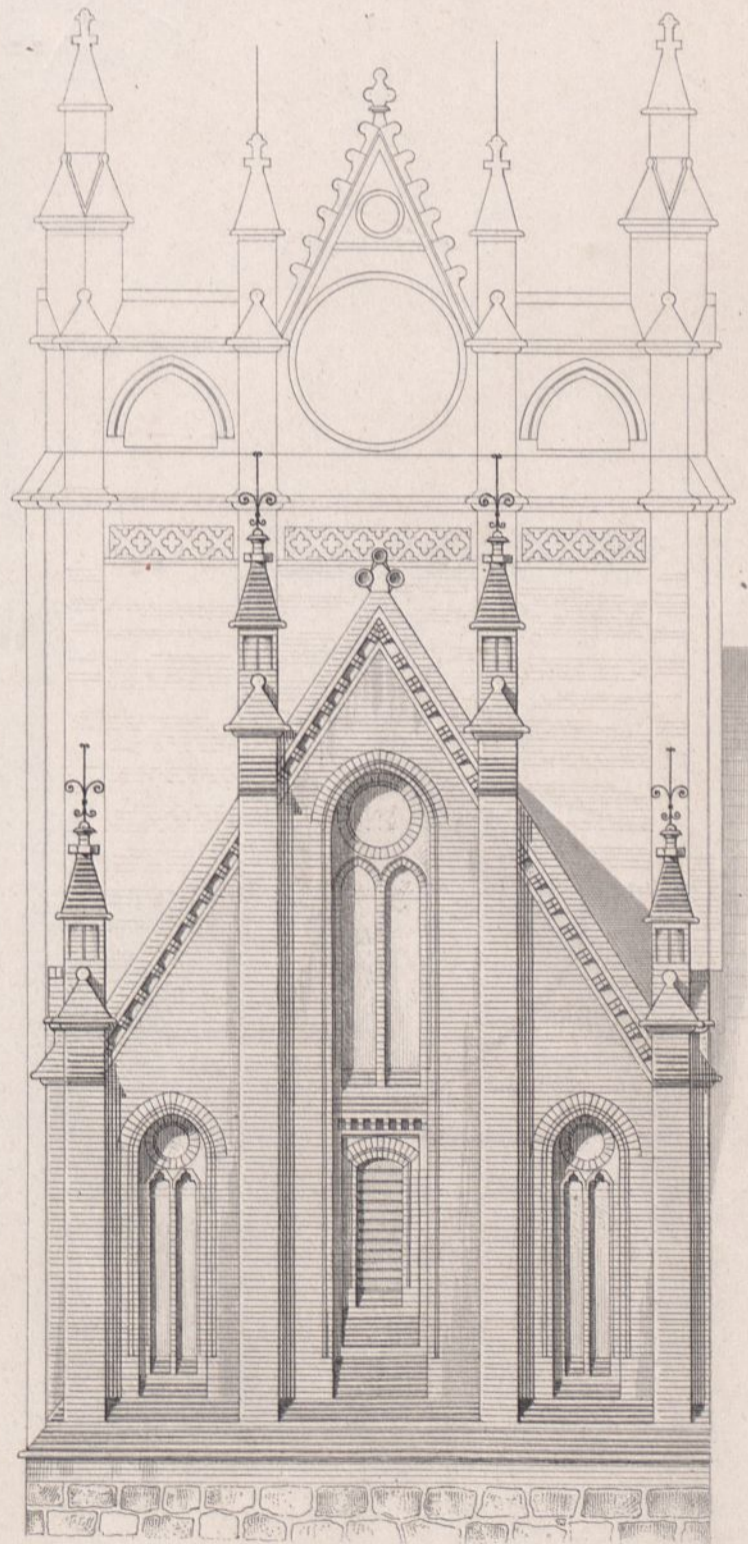
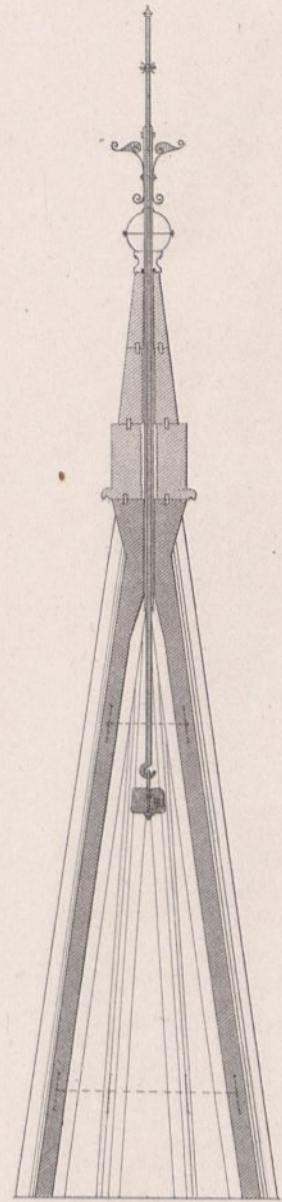

Süd - Front.

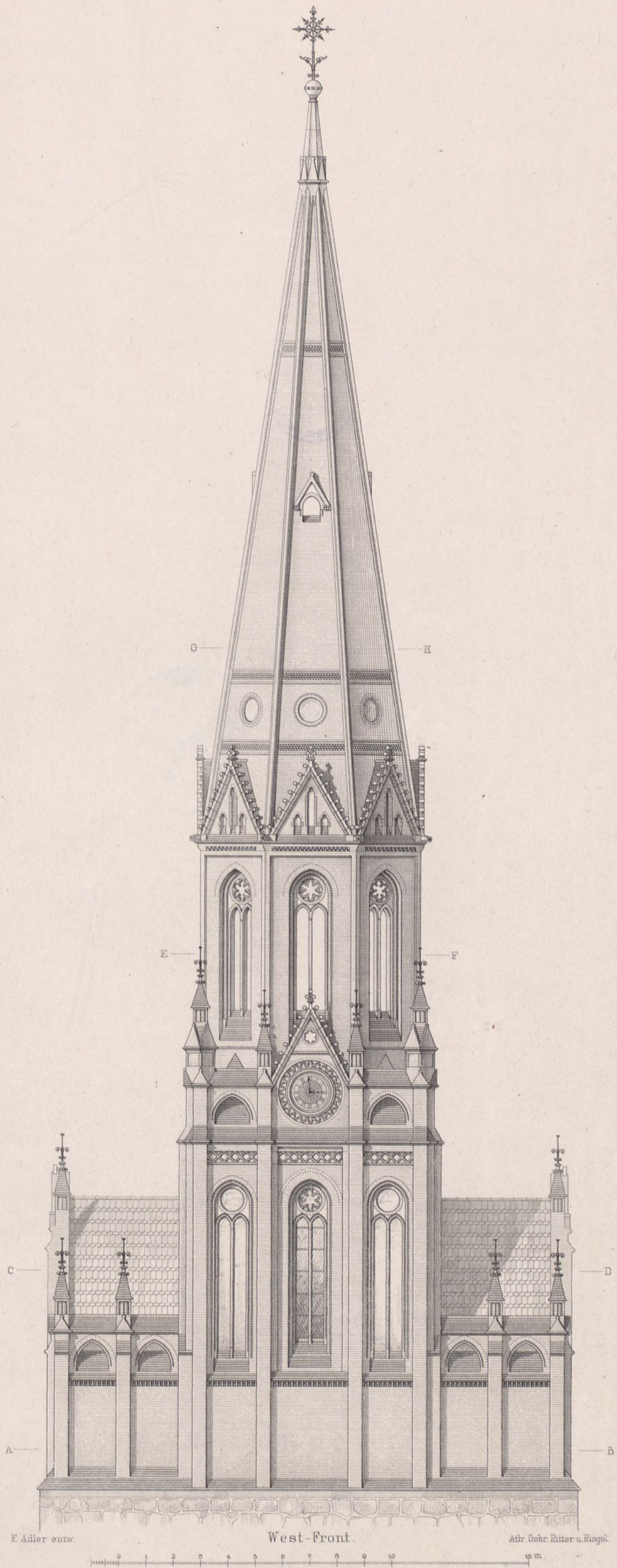

St. Nicolaus-Kirche zu Pritzwalk.

Kunstbauten der Moselbahn. Viaduct an der Pündericher Bergwand.

Pfeilergrundrisse
in der Geraden. in der Curve.

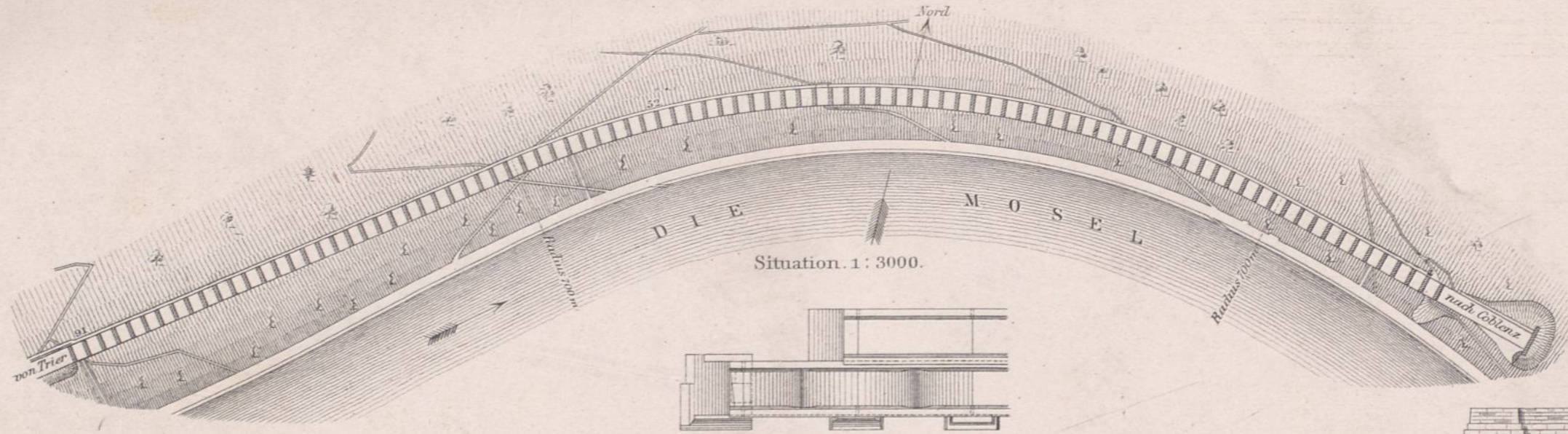
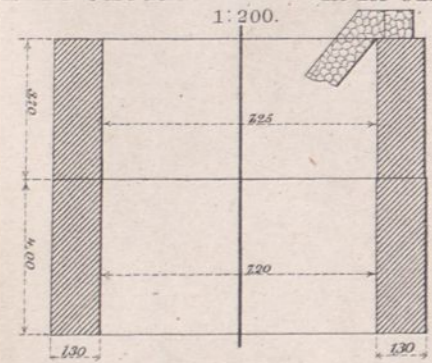

Seitenansicht
der westlichen Einfahrt des
Prinzenkopf-Tunnels.
1:400.

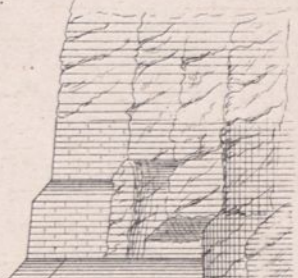

Ansicht des Viaductes. 1:400.
(92 Öffnungen à 7,2 m)

Obere Ansicht. 1:400.

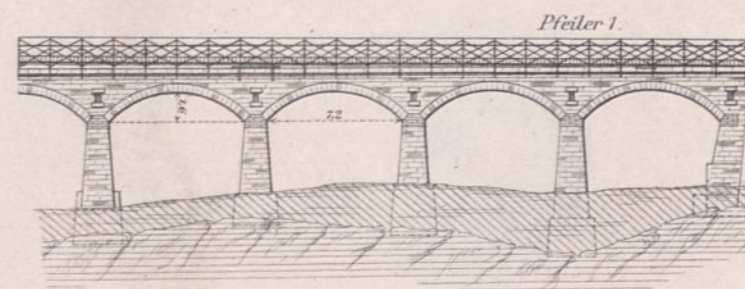
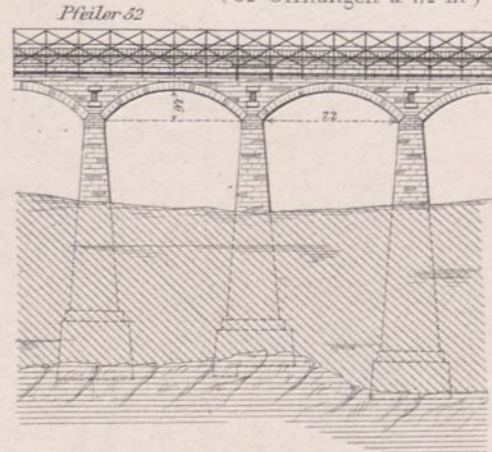
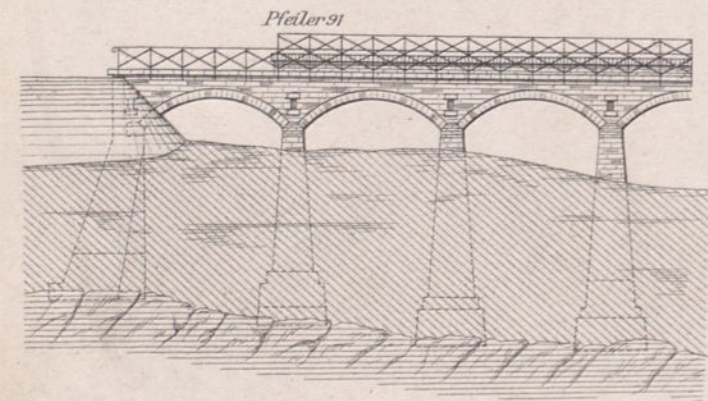

Obere Ansicht der Tunnel-Einfahrt.
1:400.

Schnitt ab.
1:400.

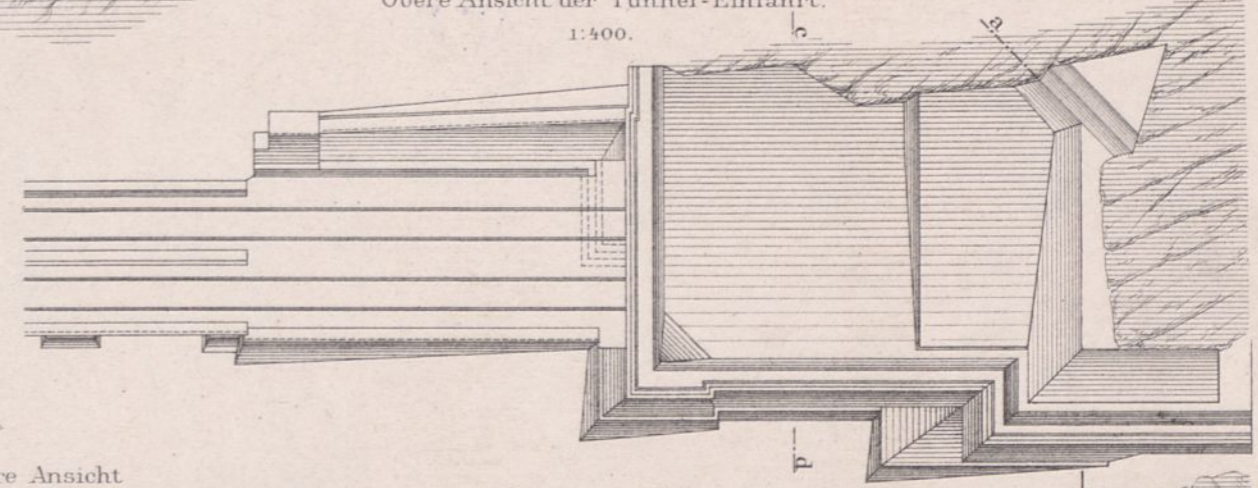
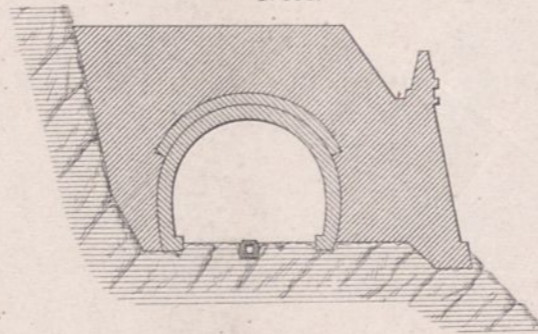

Querschnitt
durch einen Bogen des Viaductes.
1:200

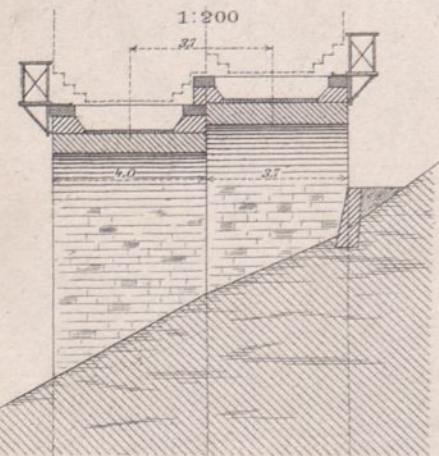

Querschnitt
durch einen Pfeiler
des Viaductes.
1:200.

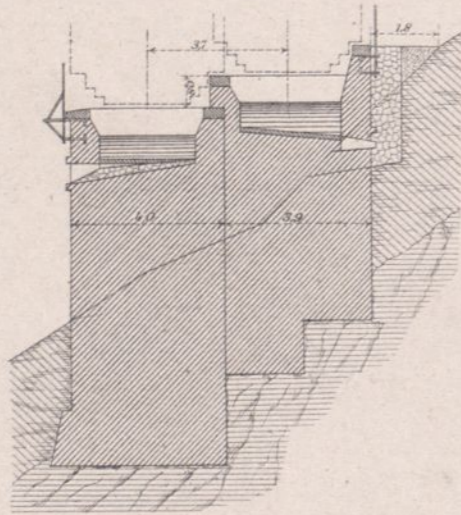

Schnitt cd.
1:400.

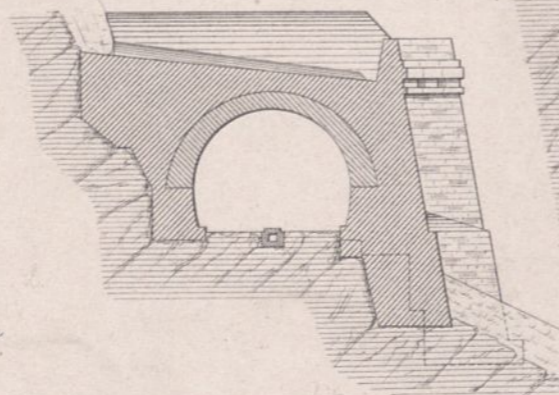

Vordere Ansicht
der Tunnel-Einfahrt.
1:400.

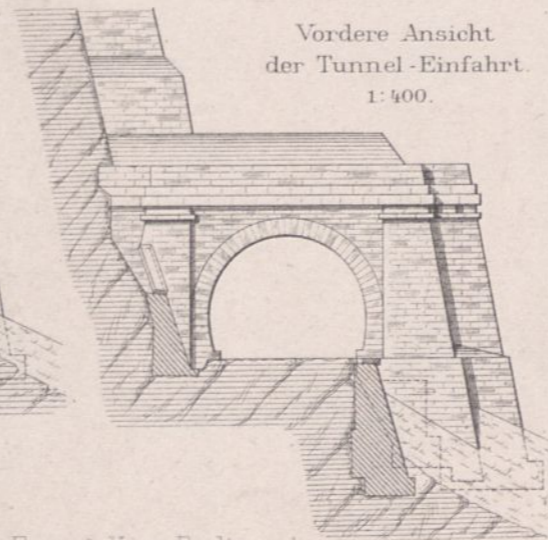

Längenschnitt der Tunnel-Einfahrt.
1:400.

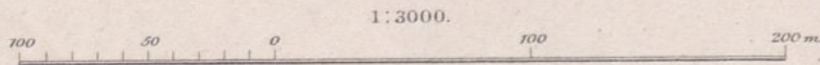
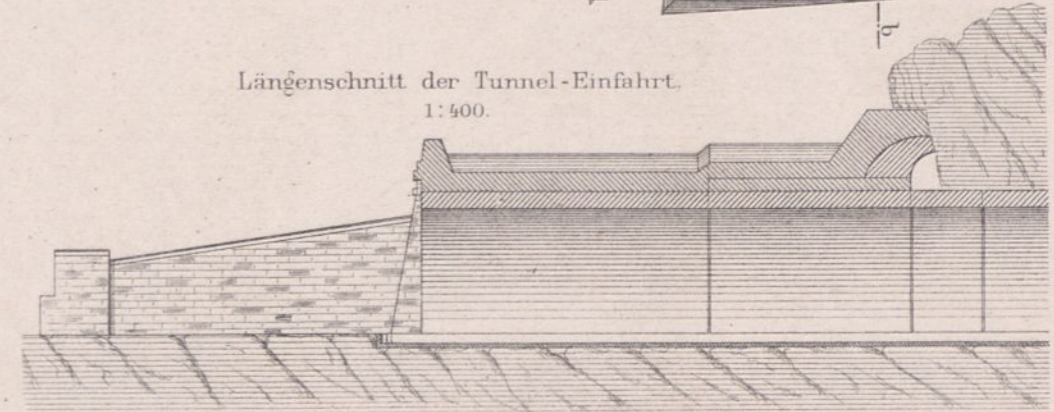

1:3000.

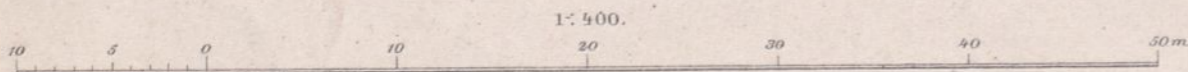

1:400.

Salm- und Lieser-Viaduct.

Ansicht des Salm-Viaductes.

Ansicht des Lieser-Viaductes.

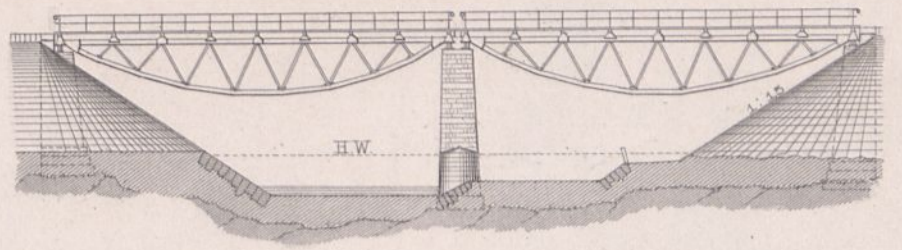
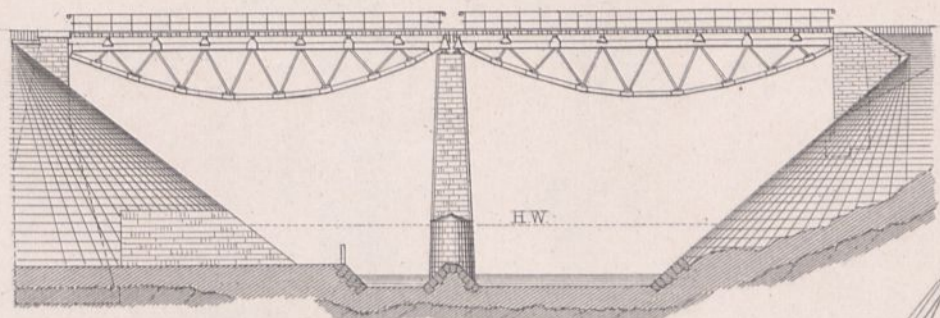

Obere Ansicht

Obere Ansicht

ohne Bohlenbelag. mit Bohlenbelag.

ohne Bohlenbelag. mit Bohlenbelag.

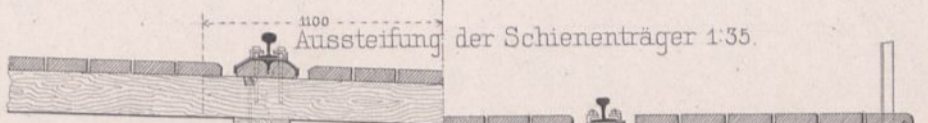
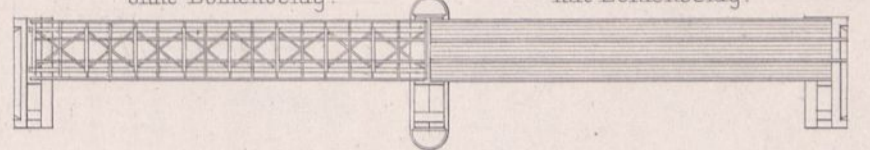
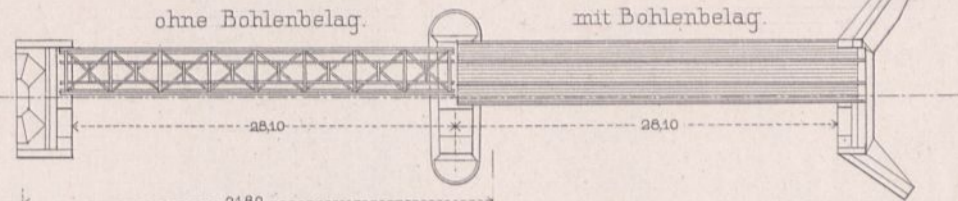

Querschnitt in Trägermitte des Salm-Viaductes. des Lieser-Viaductes. 1:35.

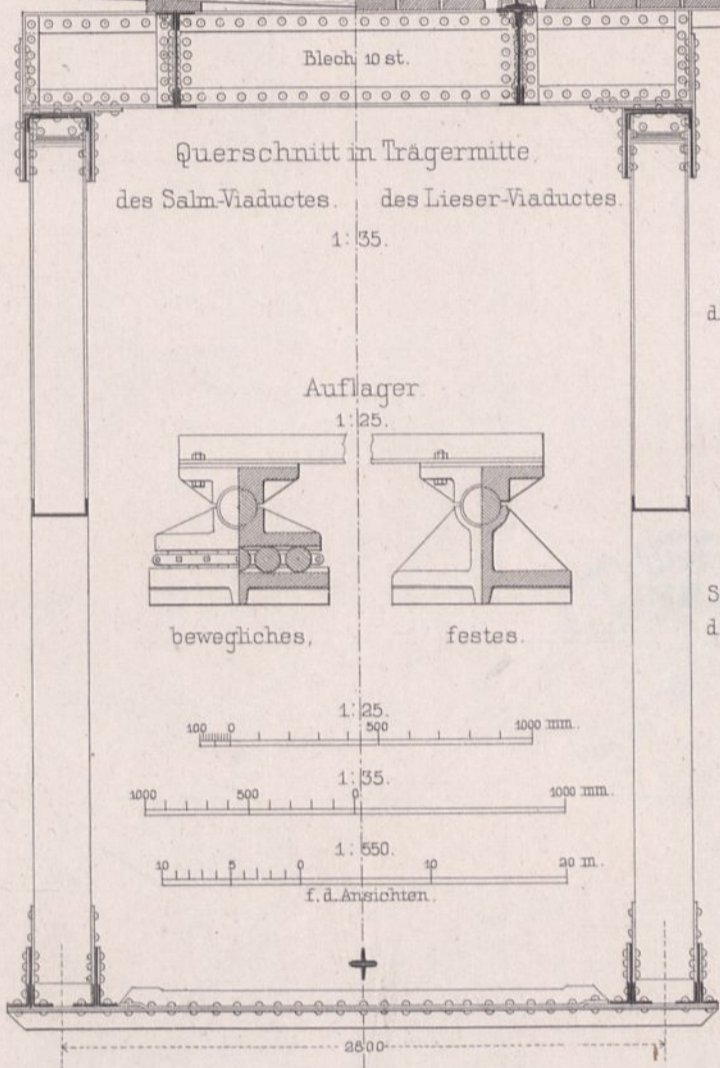

Schienenträger d. Lieser-Viaductes 1:55.

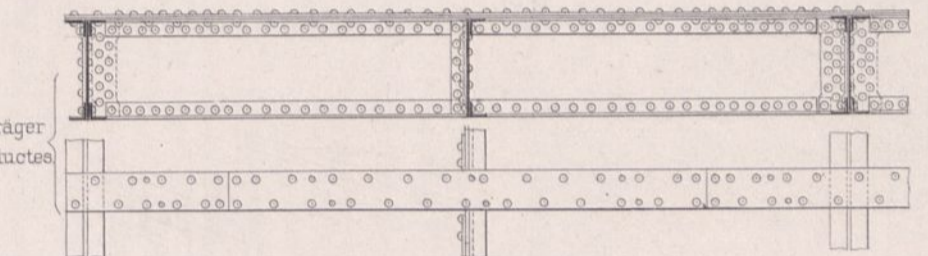
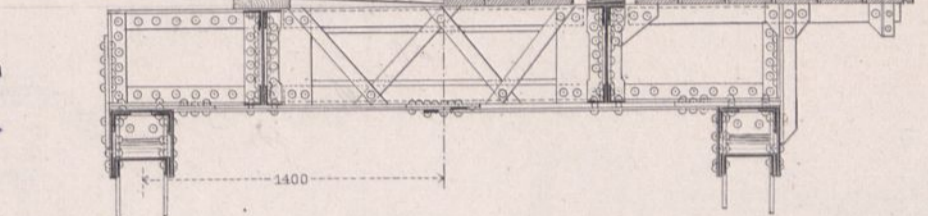

Schwellenträger d. Salm-Viaductes 1:55.

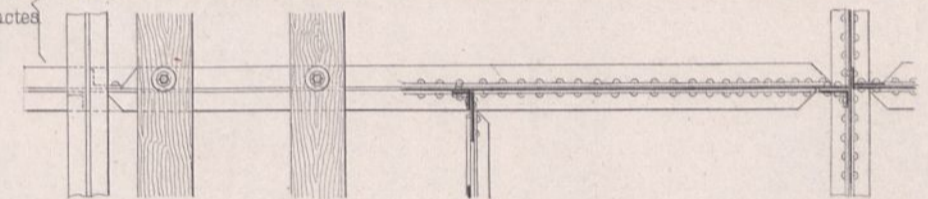
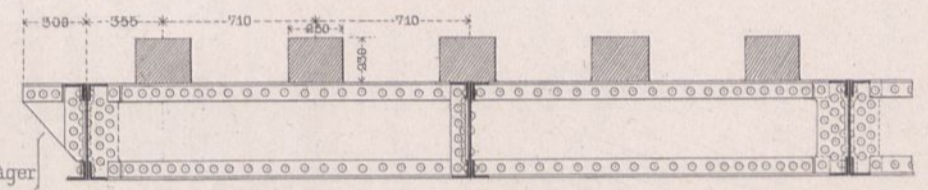

Geometrische Anordnung

Spannungen.

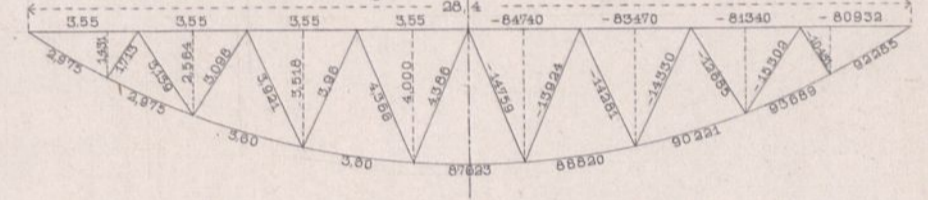

Ansichten und Querschnitte des Hauptträgers 1:30.

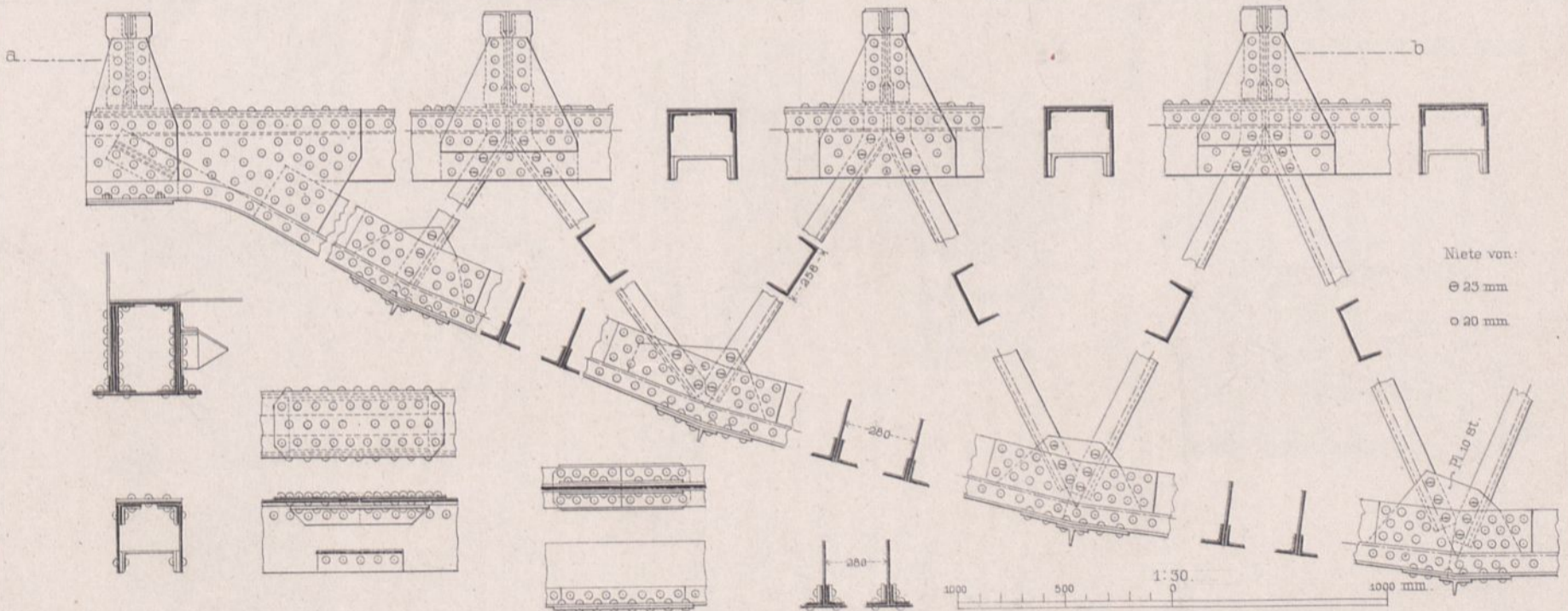

Obere Ansicht der oberen Gurtung nach Schnitt ab.

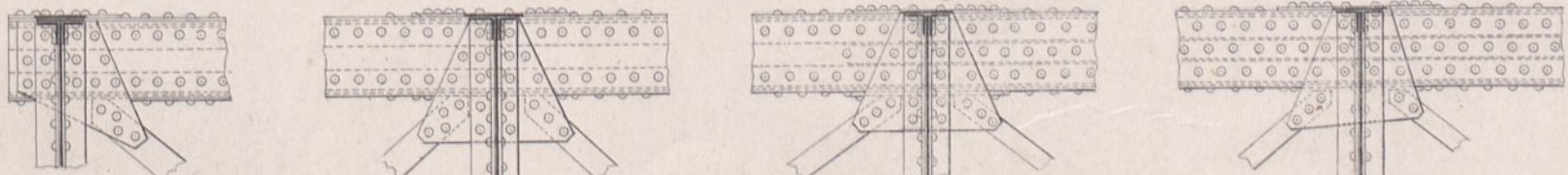

Längenschnitt der unteren Gurtung.

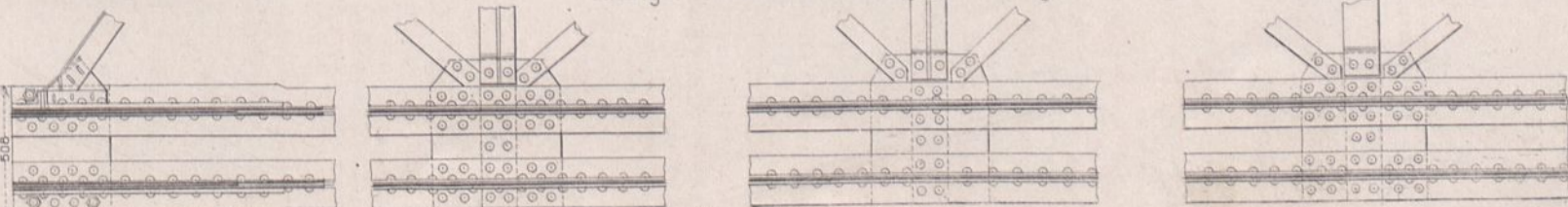

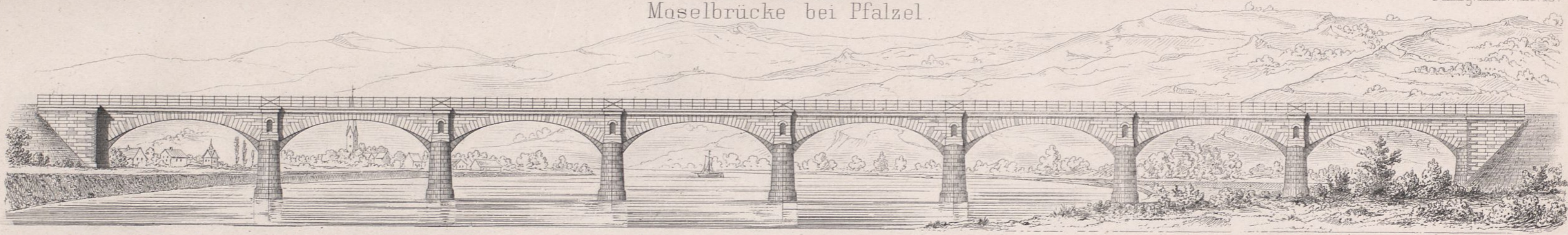

Obere Ansicht.

1: 550.

Horizontalschnitt.

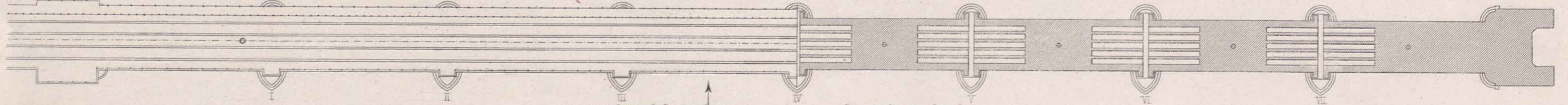

Längenschnitt.

Ansicht und Querschnitt
der Gewölbebrüstung.

Querschnitt durch
den Mittelpfeiler; den Gewölbescheitel.

Situation.
1: 4000.

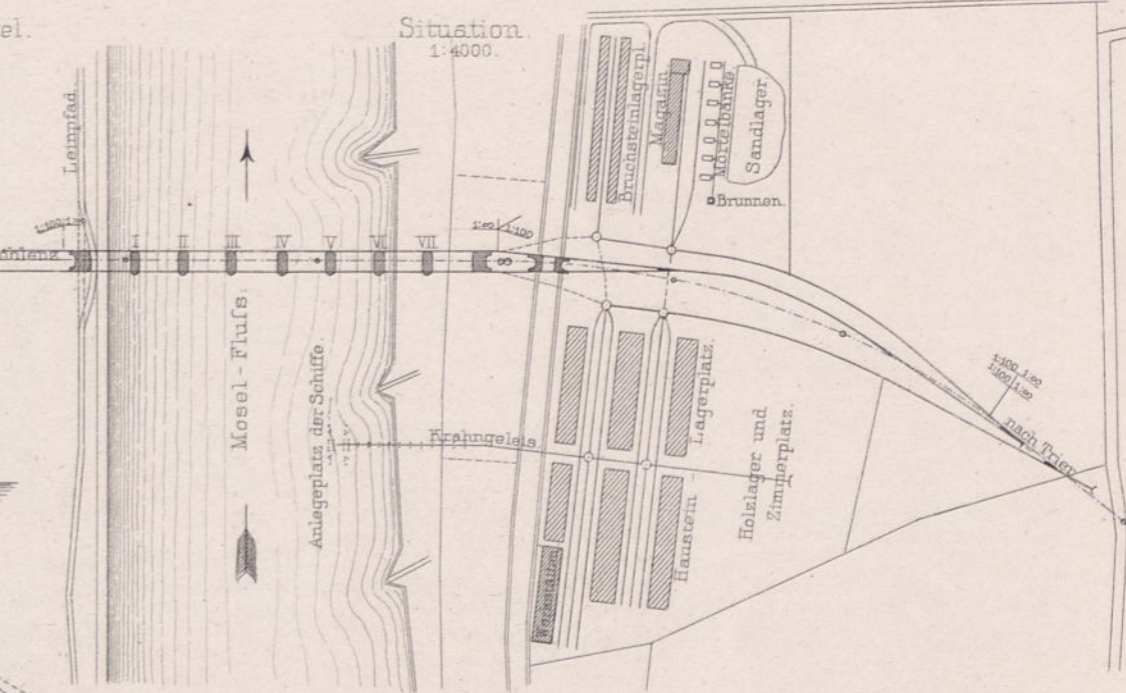
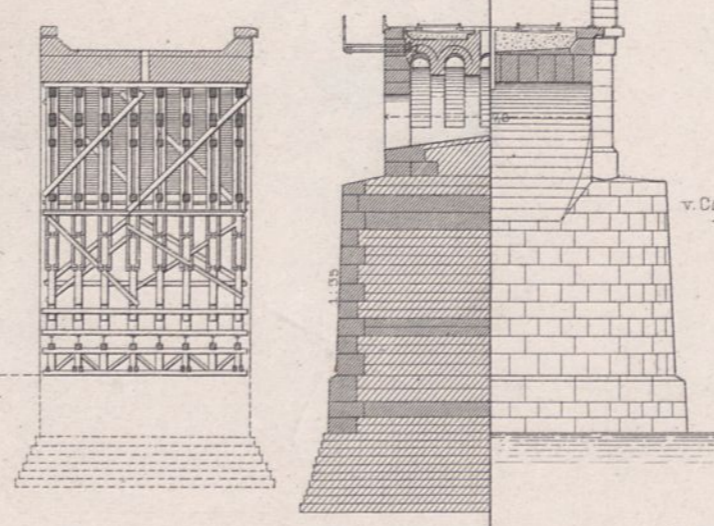
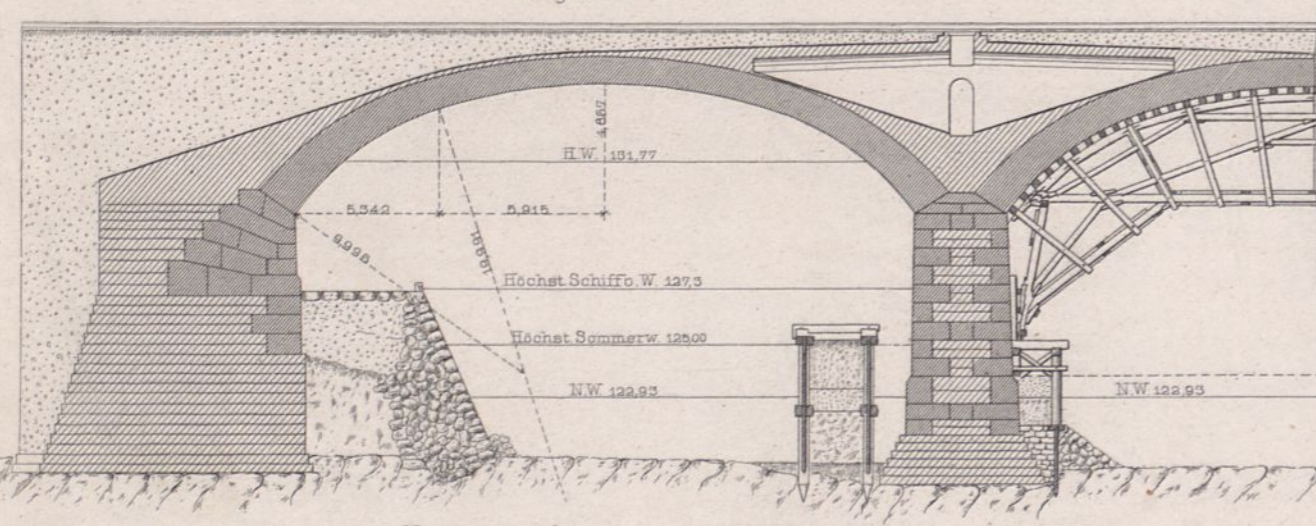

Knotenpunkt
des Howe'schen Trägers.

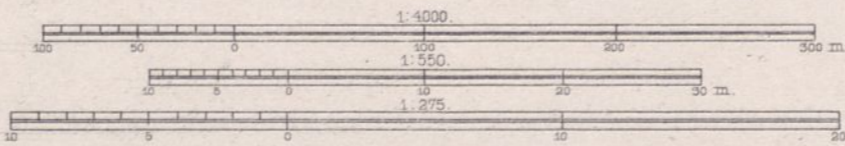
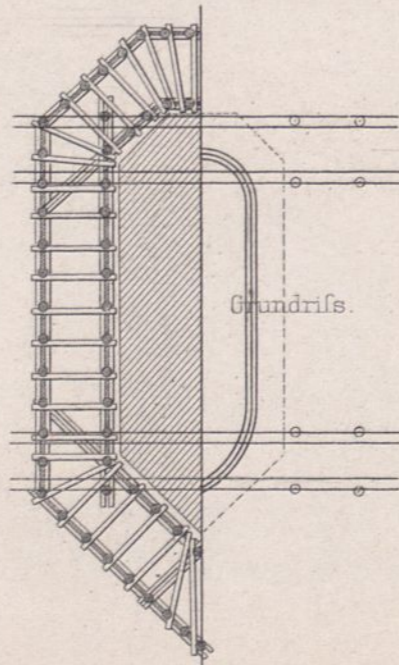
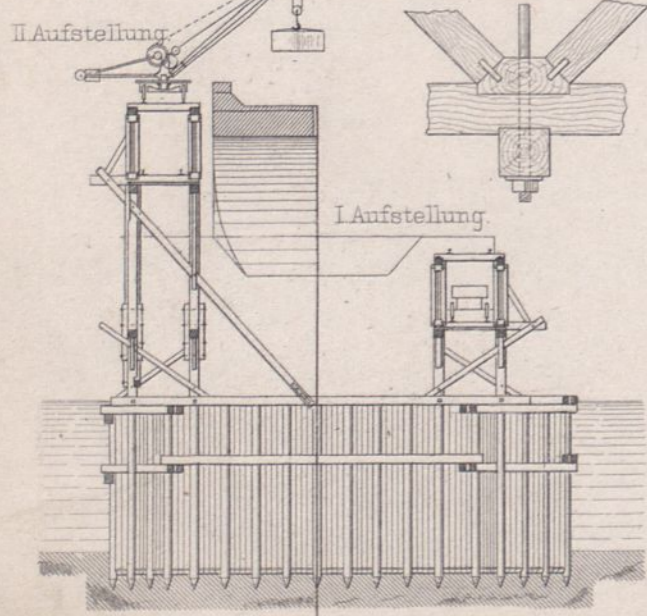

Transport- und Versetzgerüst.

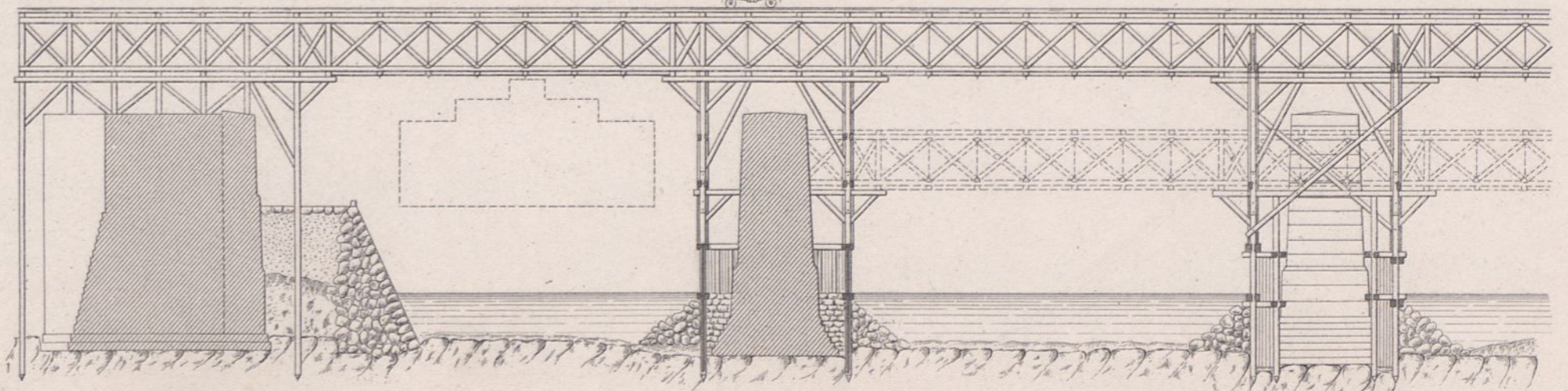

Saarbrücke bei Conz.

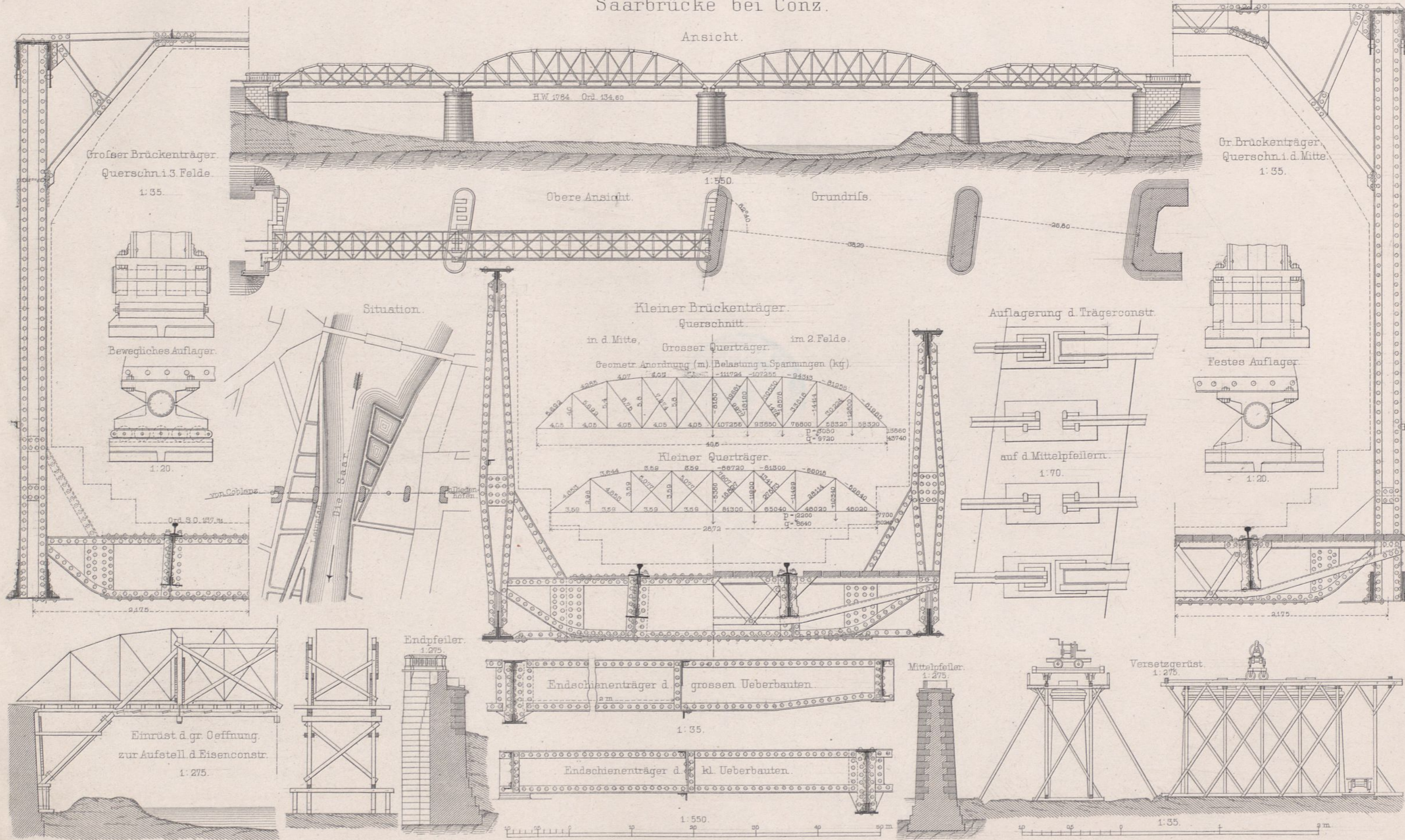

Saarbrücke bei Conz.

Ansichten und Querschnitte der Träger über den großen Öffnungen. 1:30.

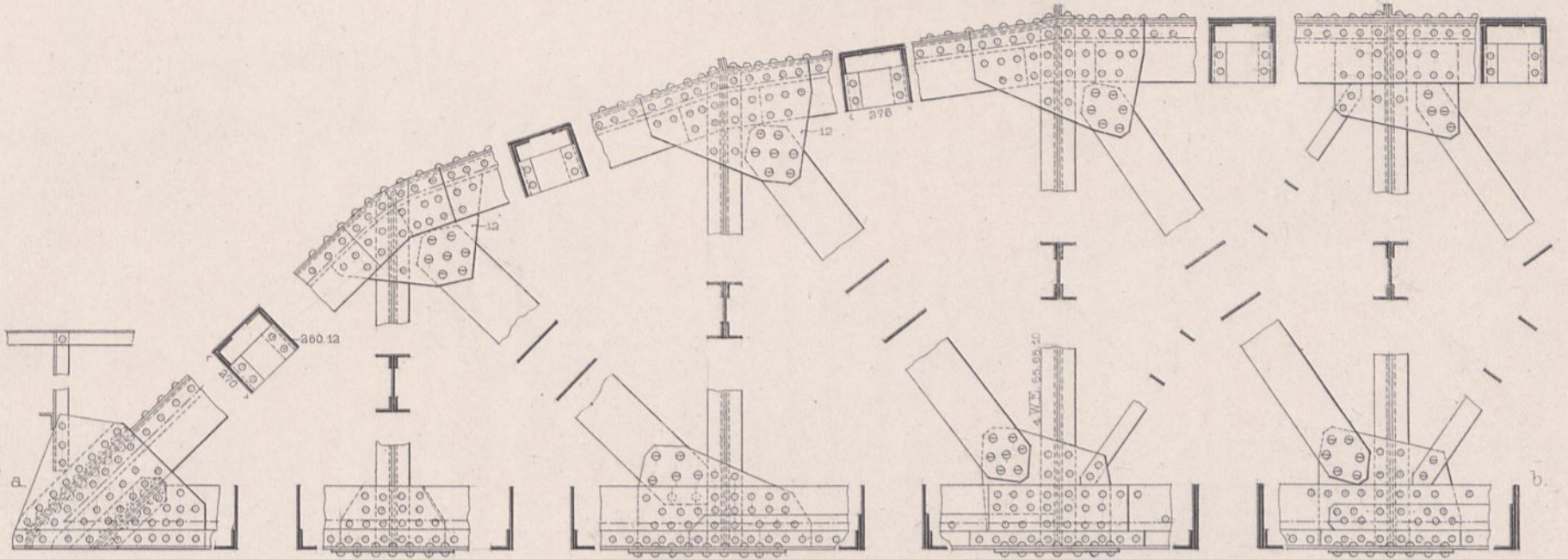

Horizontal-Schnitte durch die untere Gurtung nach a b.

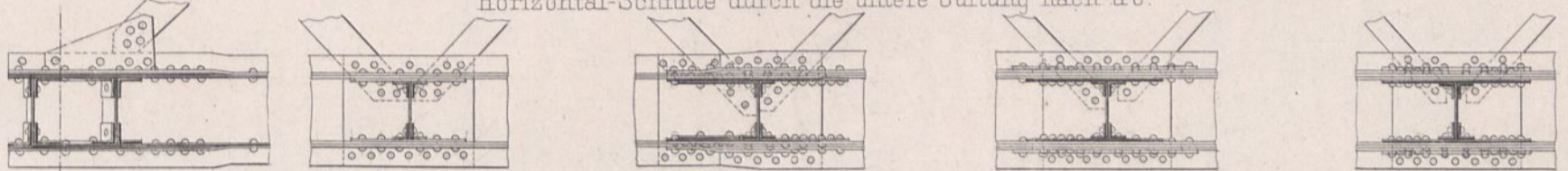

Obere Ansicht und Horizontalschnitt 1:80.

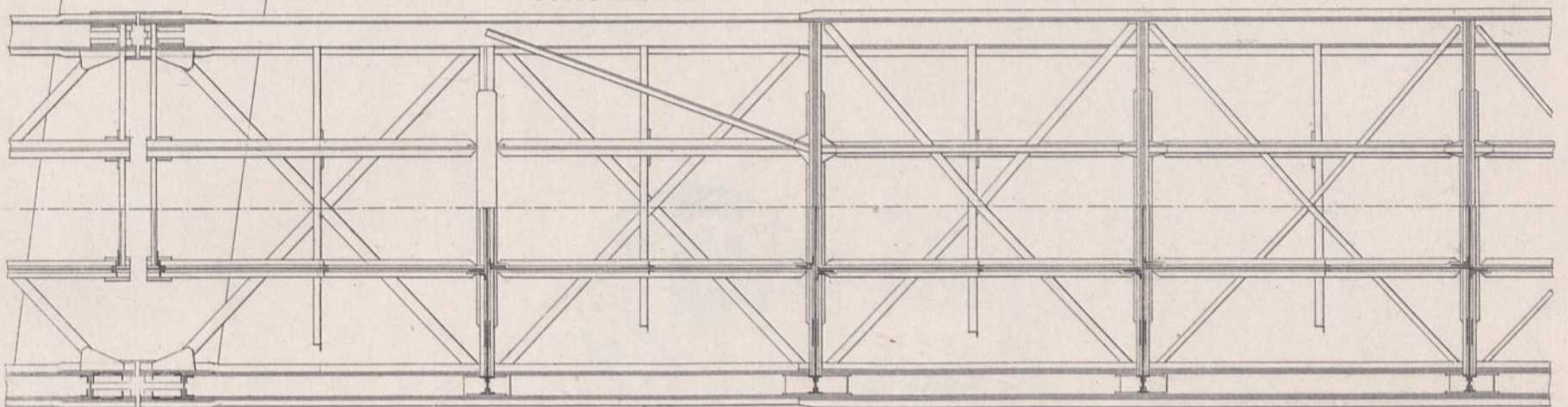

Ansichten und Querschnitte der Träger über den kleinen Öffnungen. 1:30.

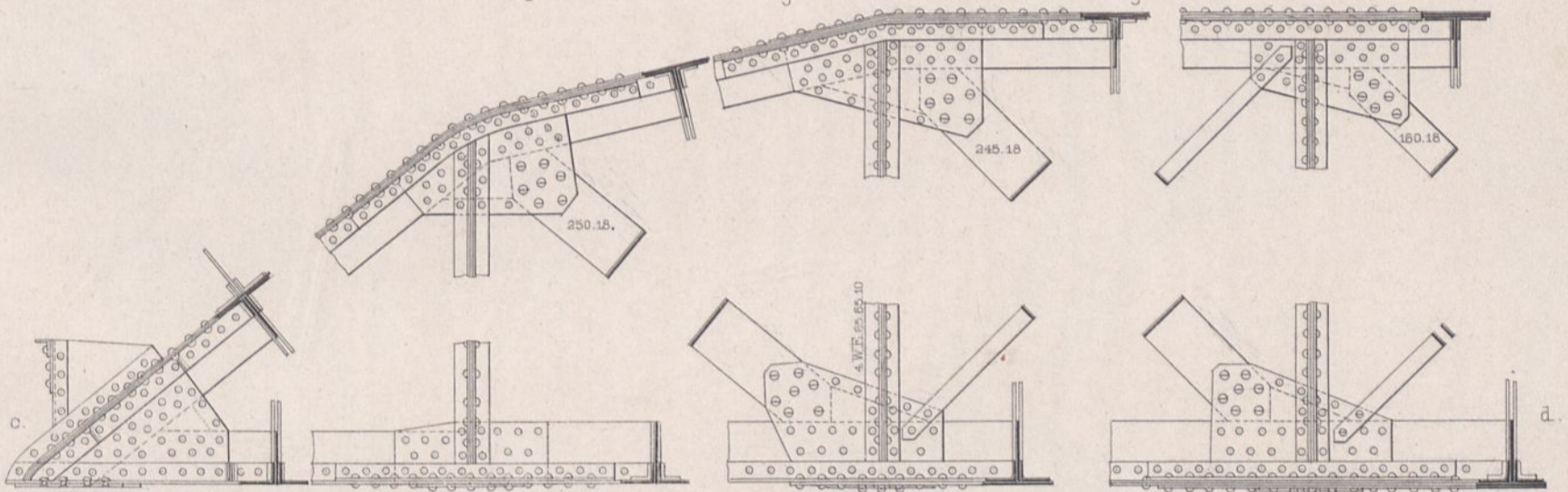

Horizontal-Schnitte durch die untere Gurtung nach cd.

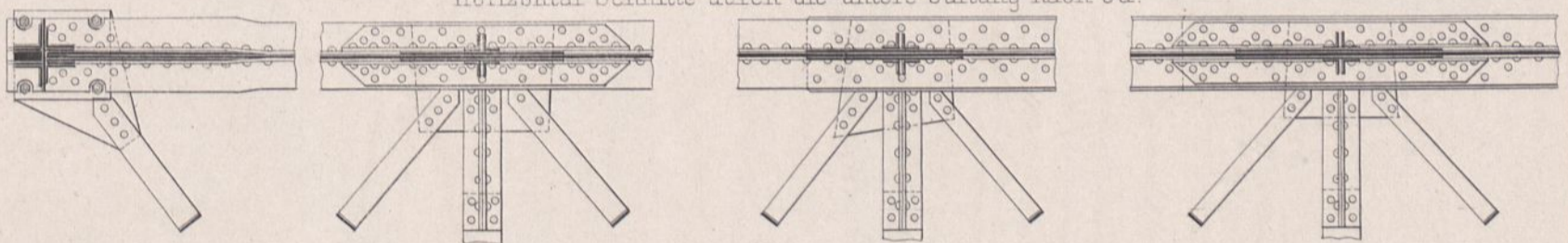

Obere Ansicht und Horizontalschnitt 1:80.

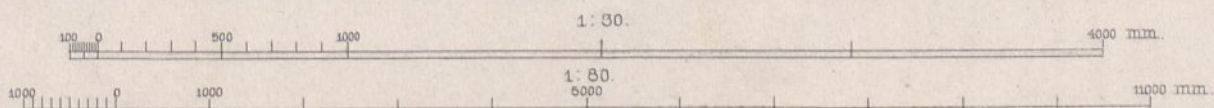
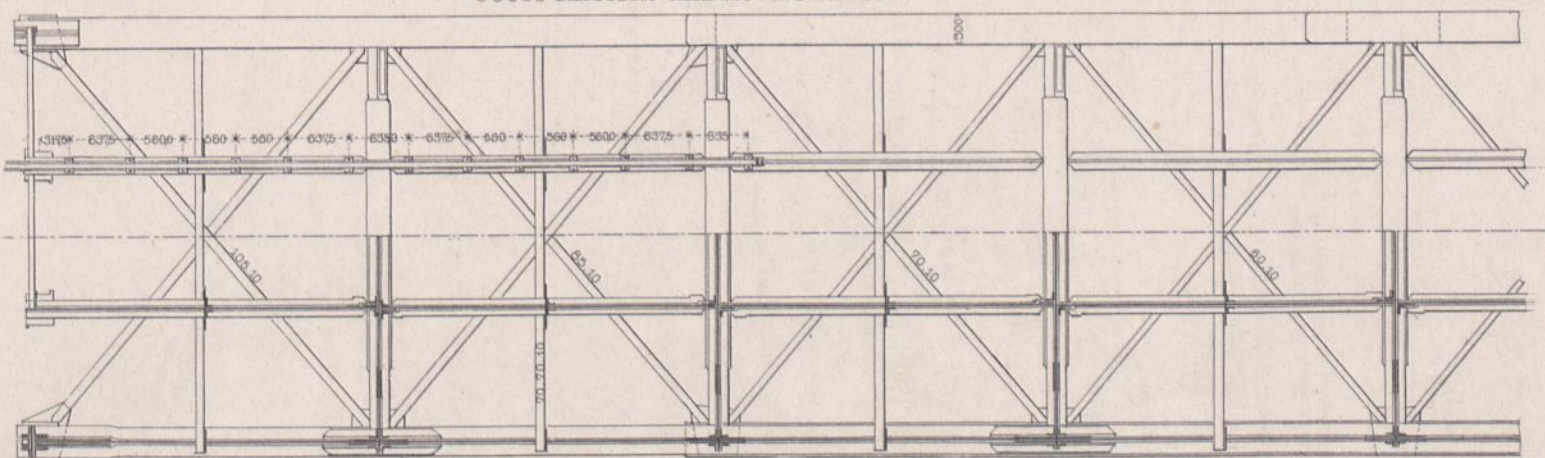

Preussische Staatsbauten

welche i. J. 1882 in der Ausführung begriffen gewesen sind.

Corrections-Plan der Ems bei Dorf Borsum.

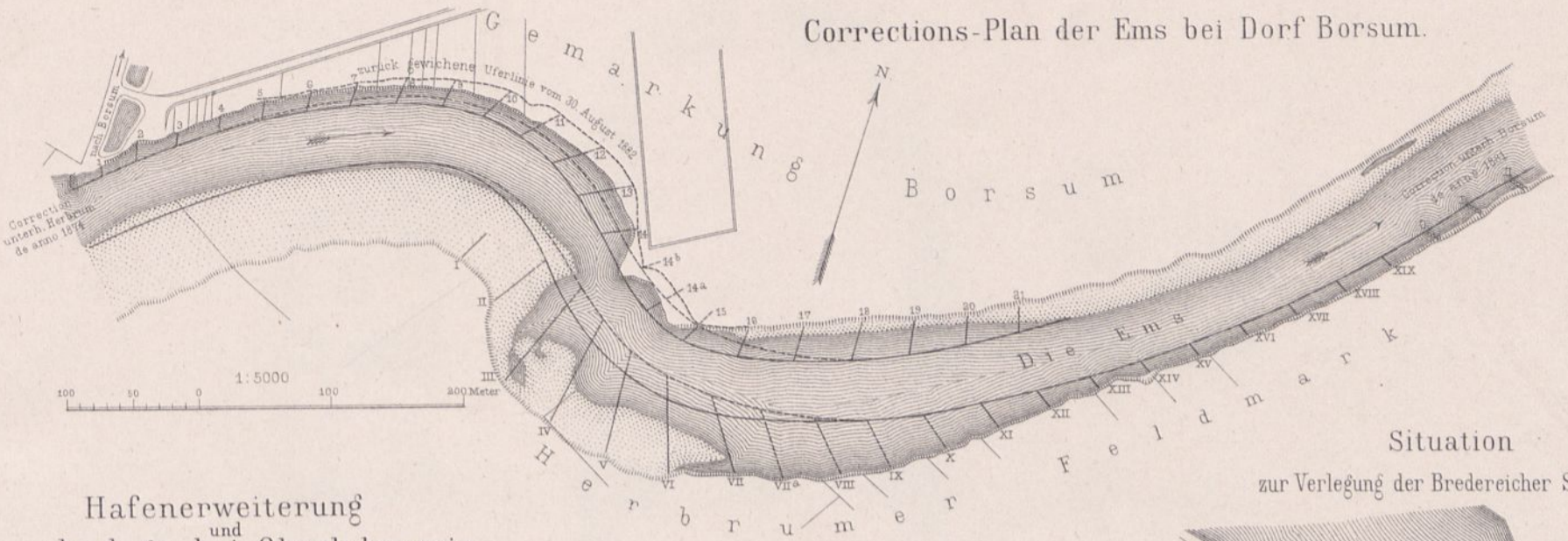

Situation zur Verlegung der Bredereicher Schleuse.

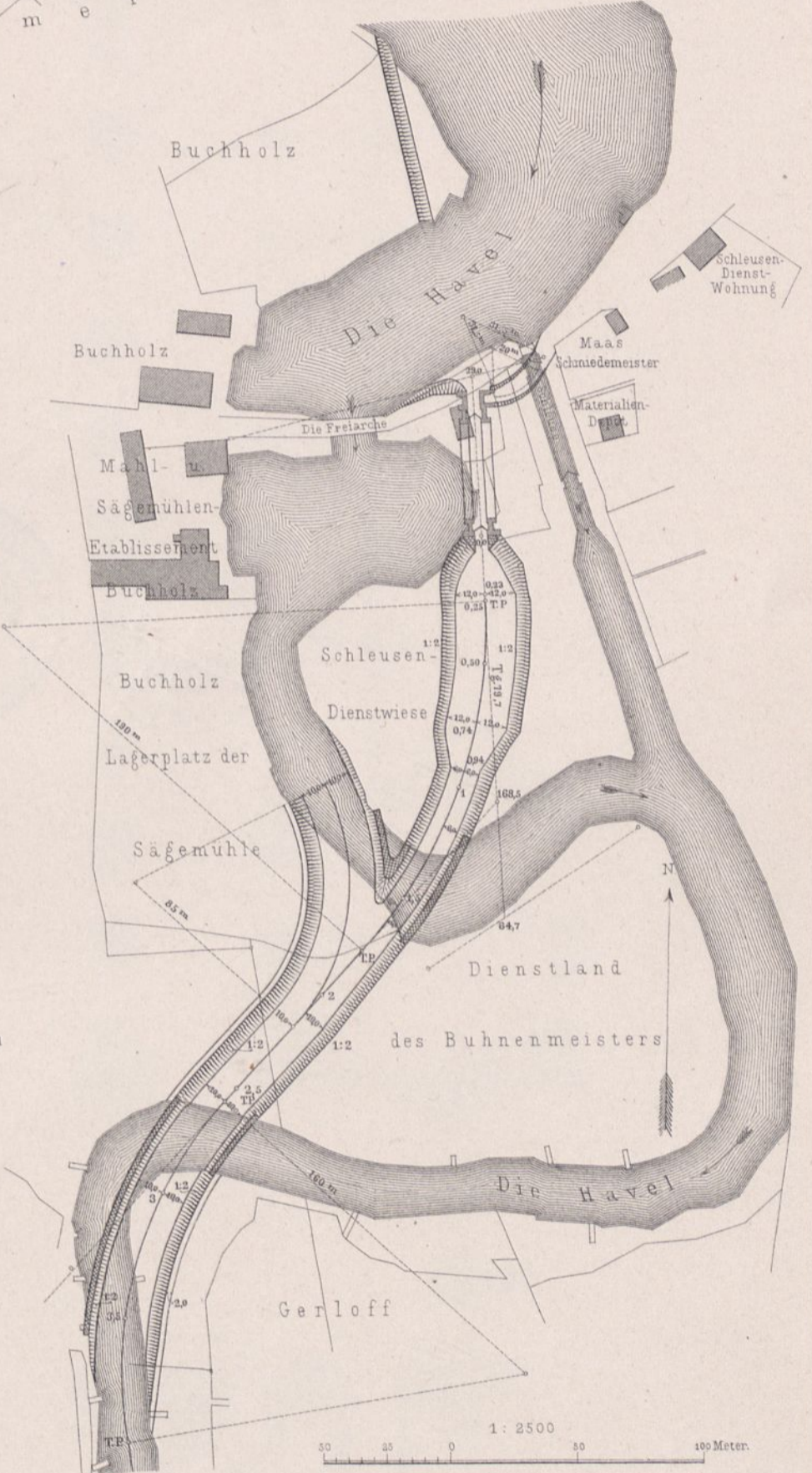

Hafenerweiterung und Canalanlage bei Oberlahnstein.

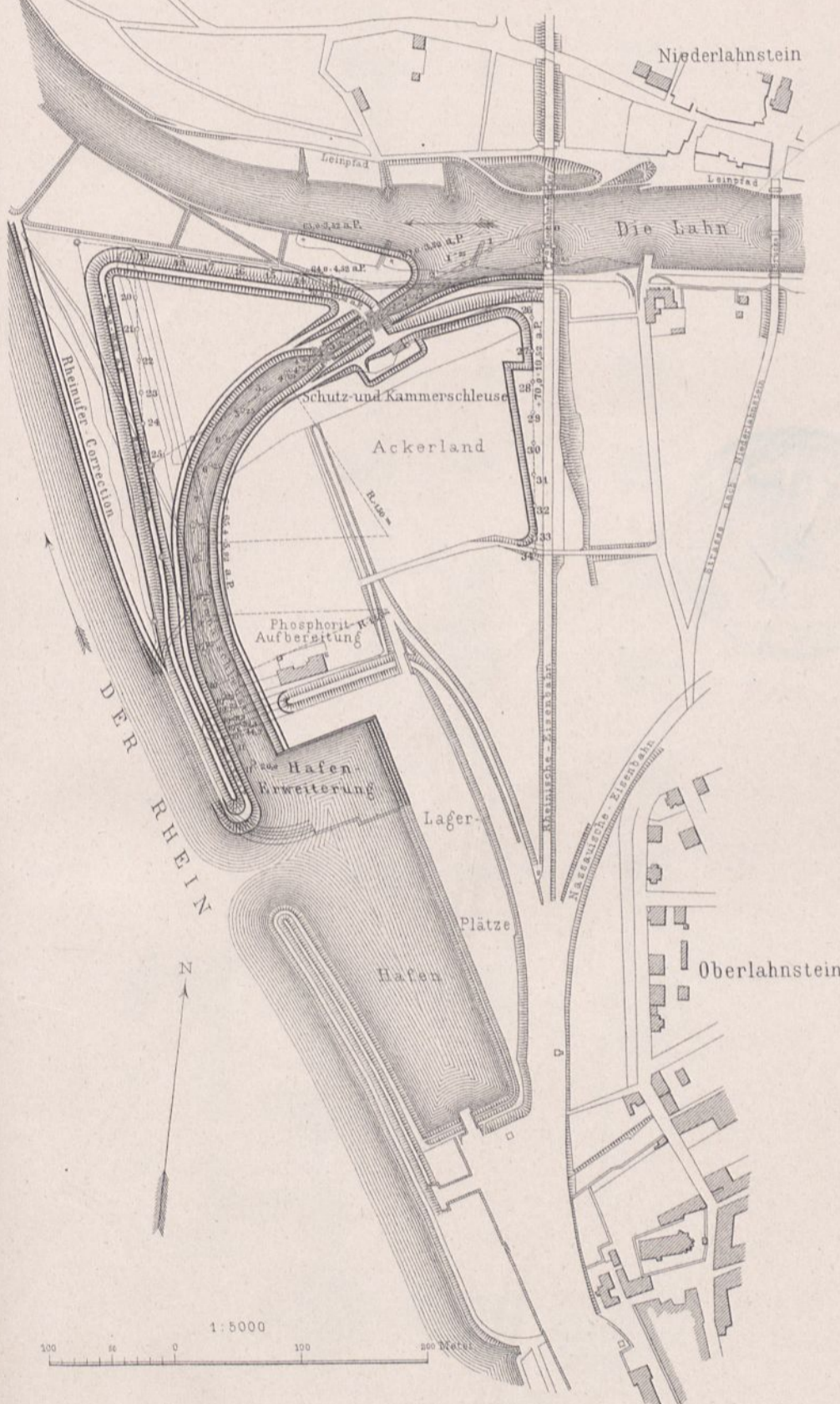

Lahnwehr bei Löhnberg.

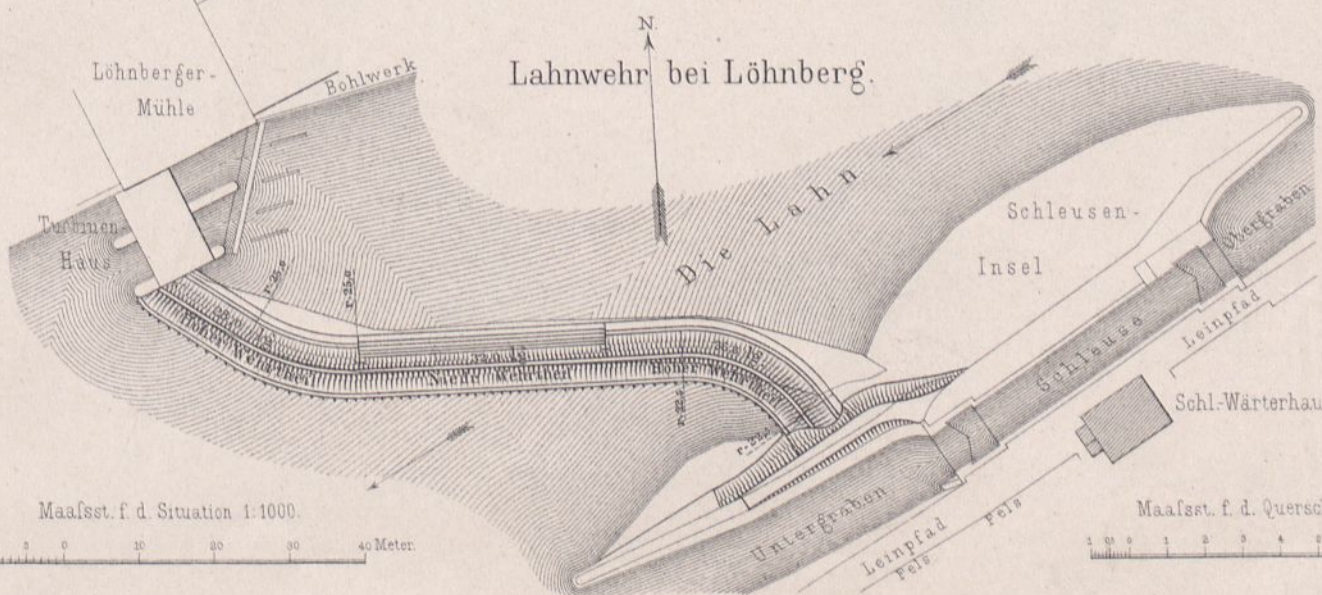

Querschnitt der hohen Wehrtheile.

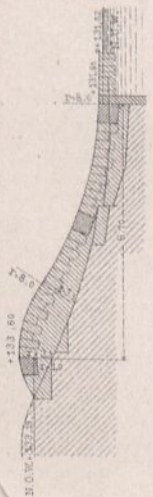

Querschnitt der niedrigen Wehrtheile.

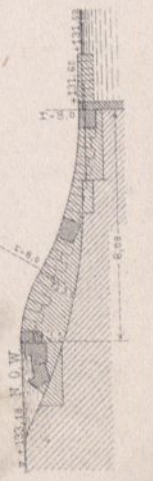

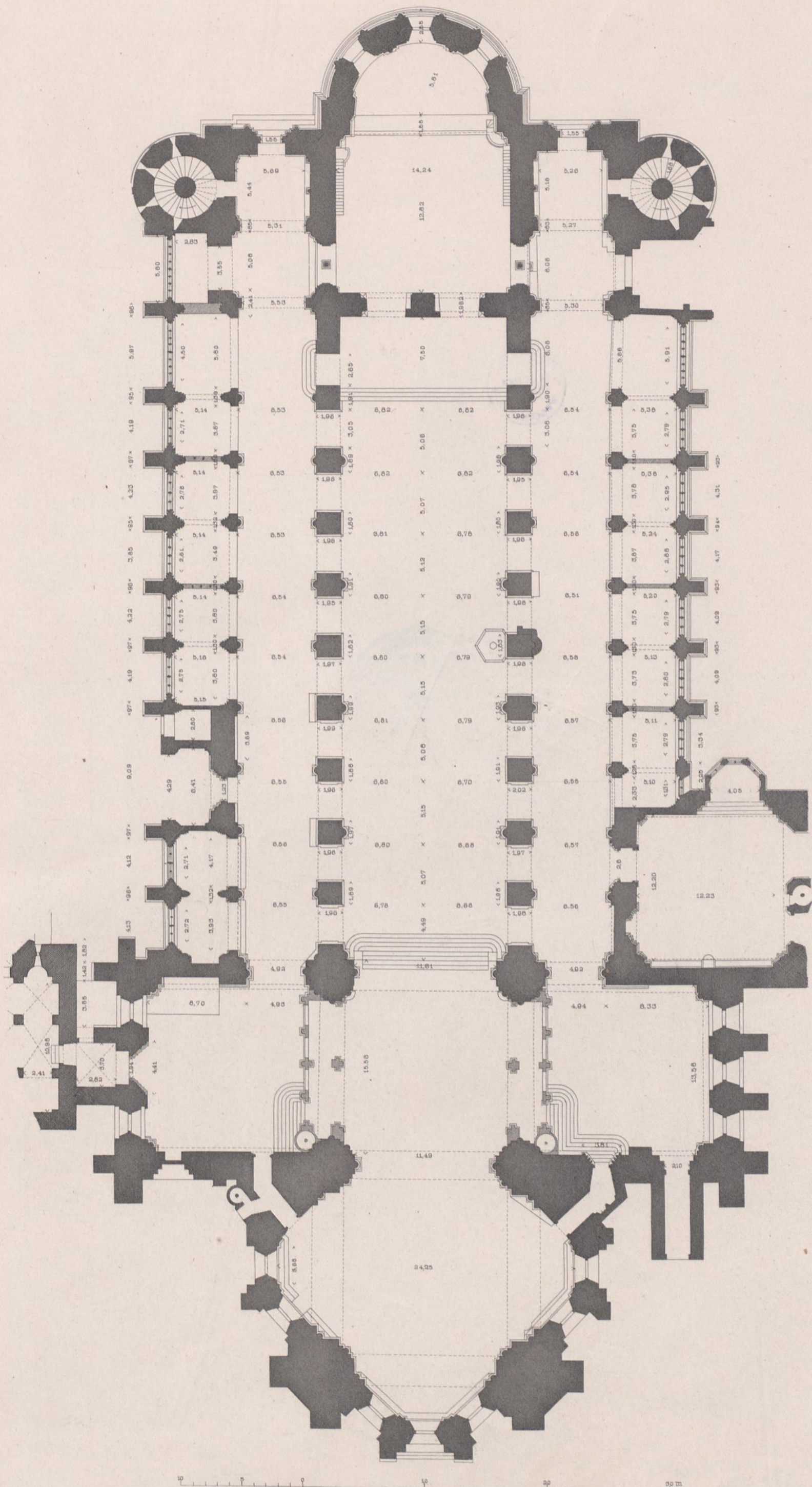

Walther gest.

Dom zu Mainz.

Ernst & Korn. Berlin.

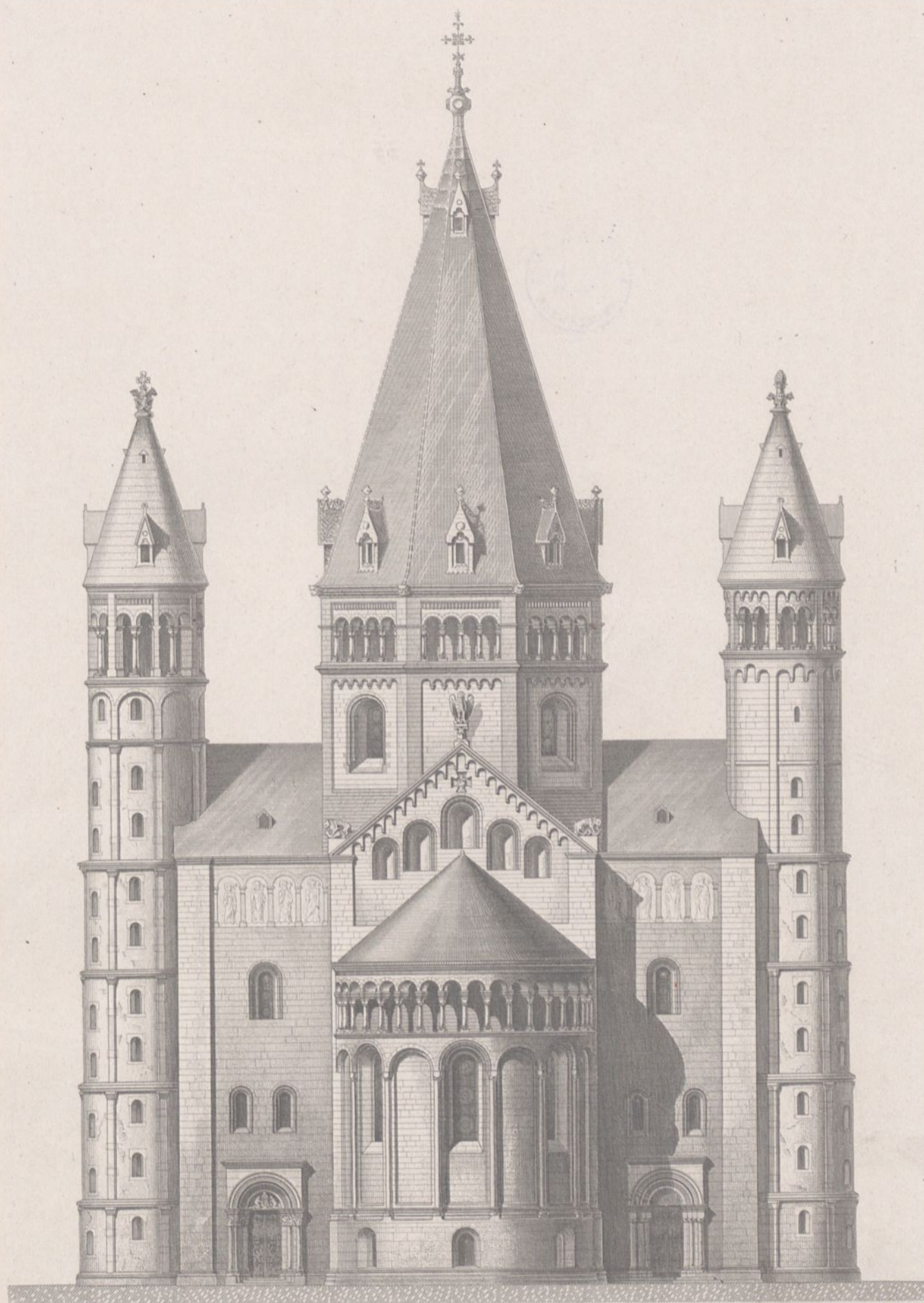

Arch. Gebr. Ritter u. Regel.

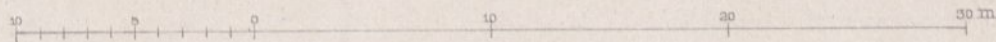

Dom zu Mainz.

Oestliche Ansicht nach dem Entwurf

von P.J.H. Cuypers.

Ernst & Korn, Berlin.

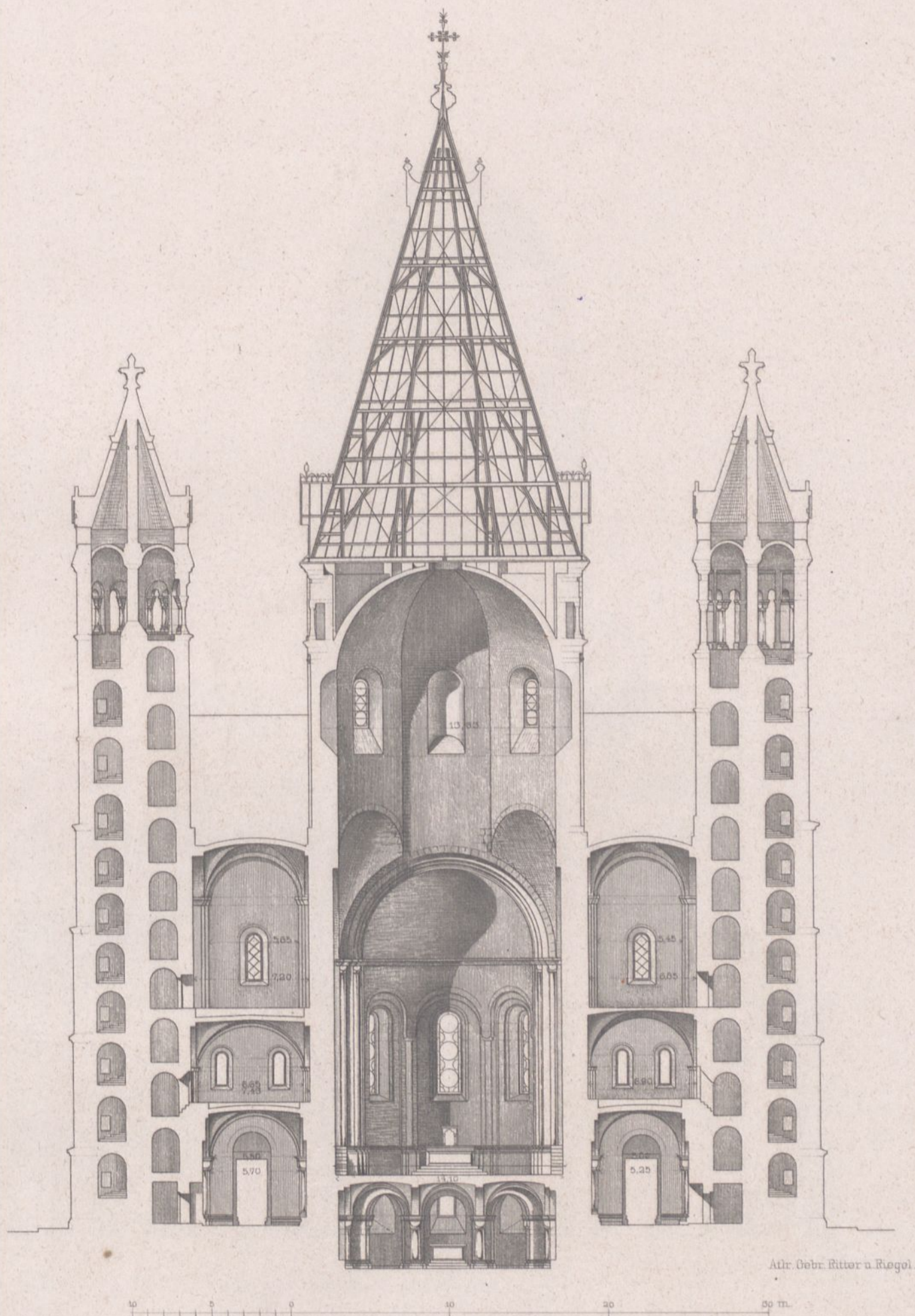

Arch. Gebr. Ritter u. Regel.

Dom zu Mainz.

Ostbau, von Westen gesehen, mit den Ergänzungen

nach dem Entwurf von P.J.H. Cuyppers.

Ernst & Korn Berlin.

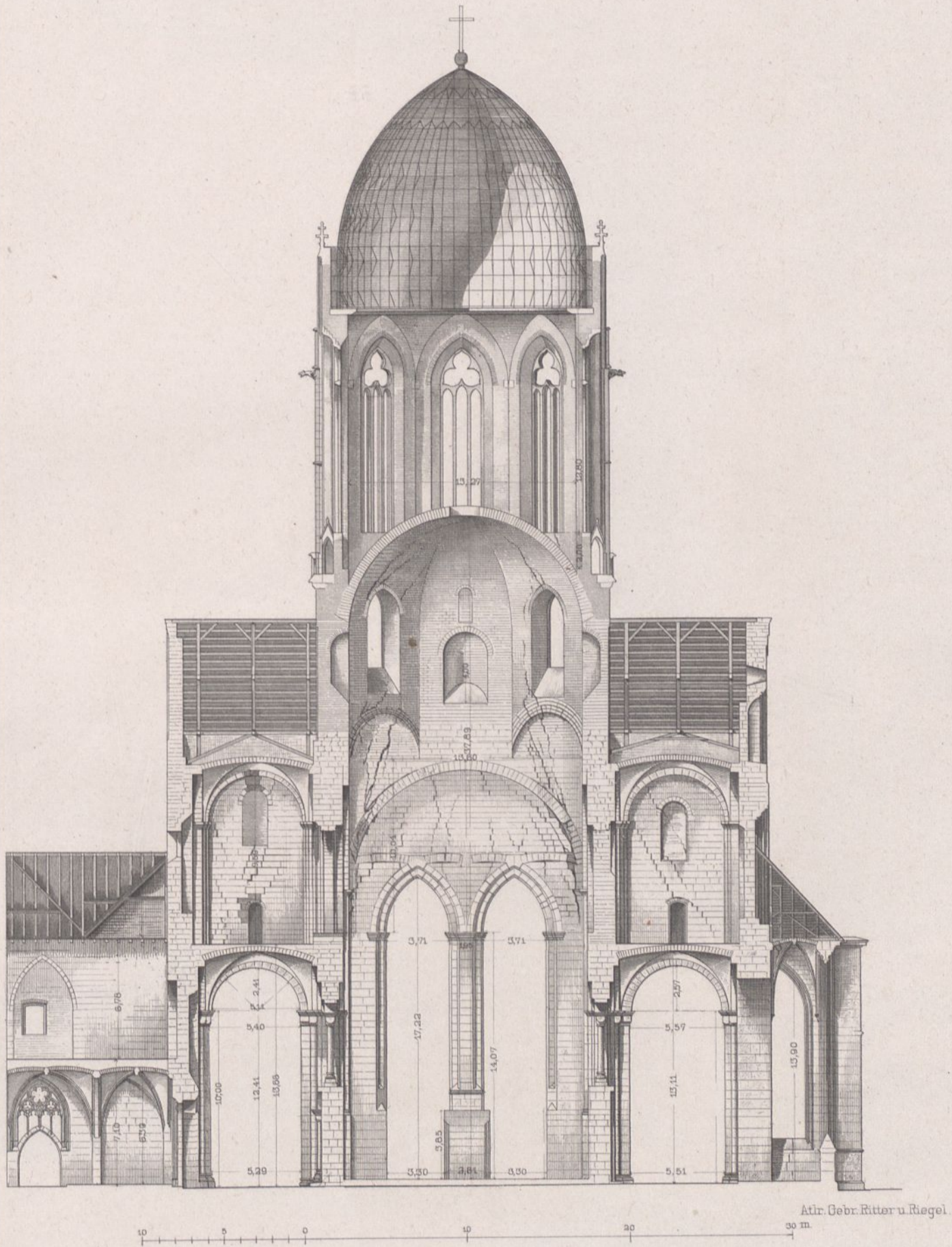

Dom zu Mainz.

Ostbau, vom Ostchore aus gesehen, Blick gegen Westen.

Zustand vor 1870.

Ernst & Korn, Berlin.

Längenansicht der Südseite

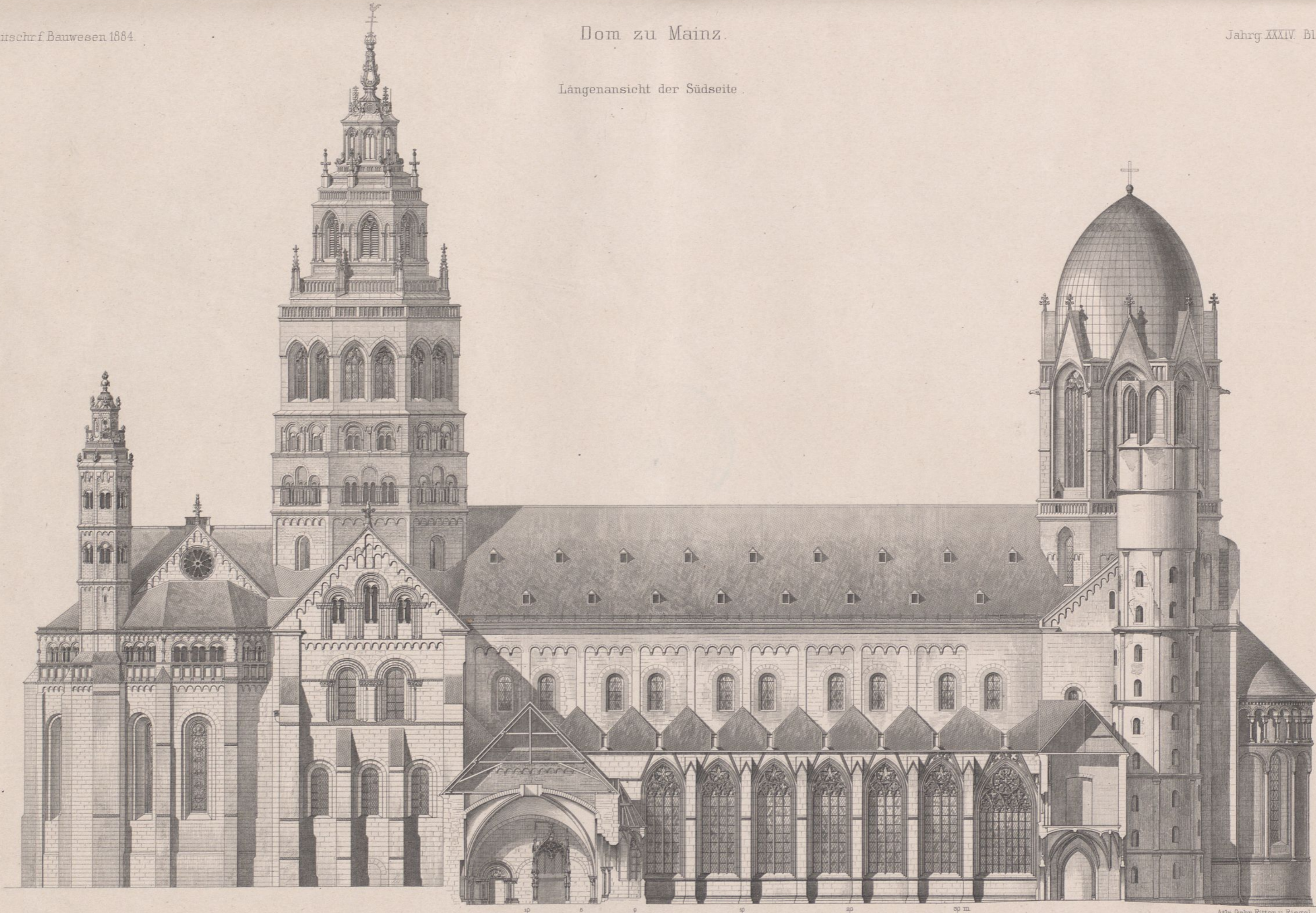

Arch. Gebr. Ritter u. Riegel.

Ostchor im Zustand vor 1870.

Dom zu Mainz.

Längenschnitt.

Zustand vor 1870.

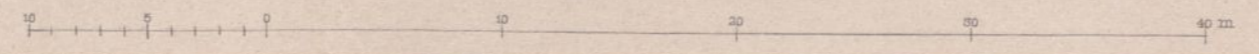
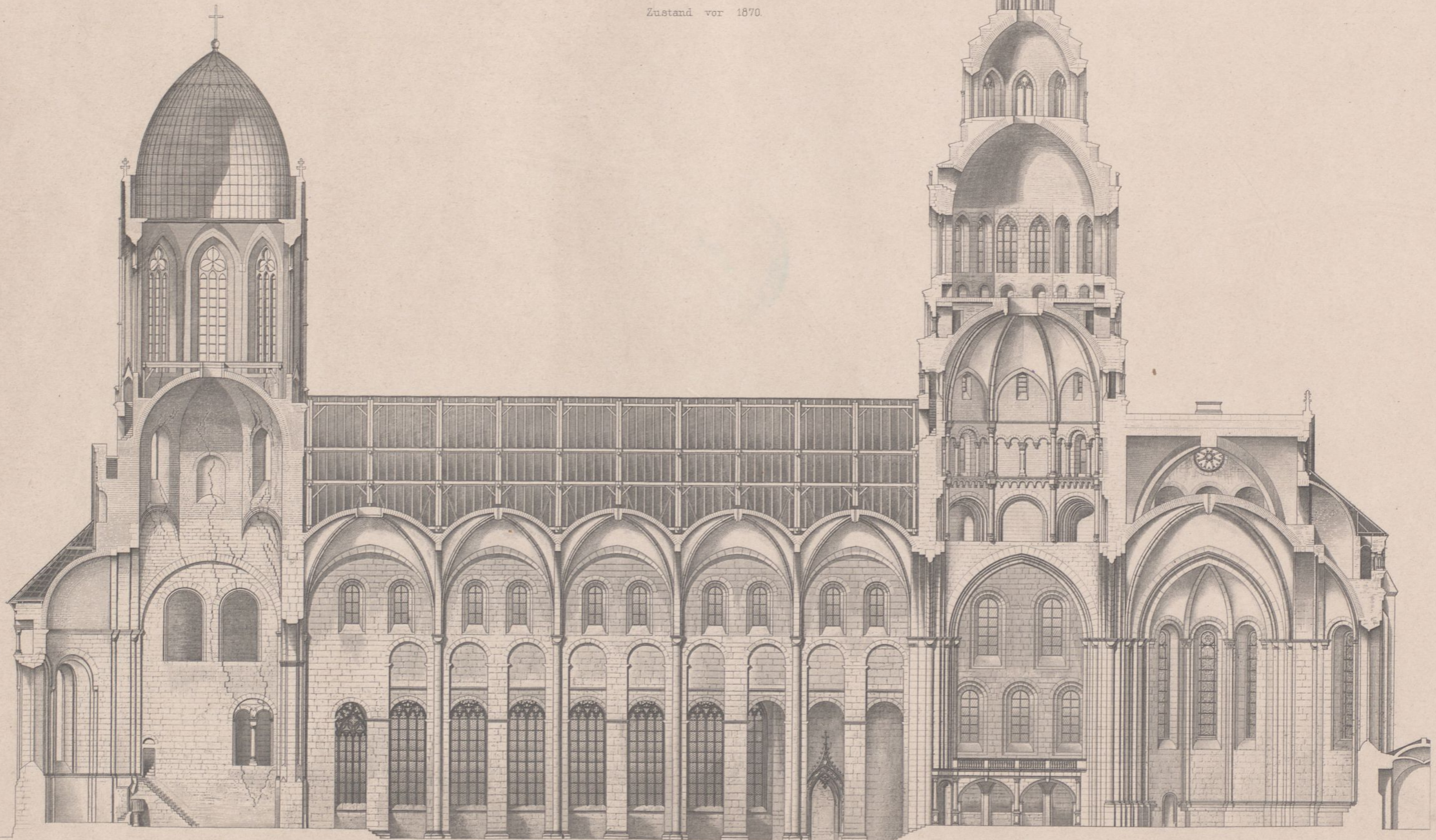

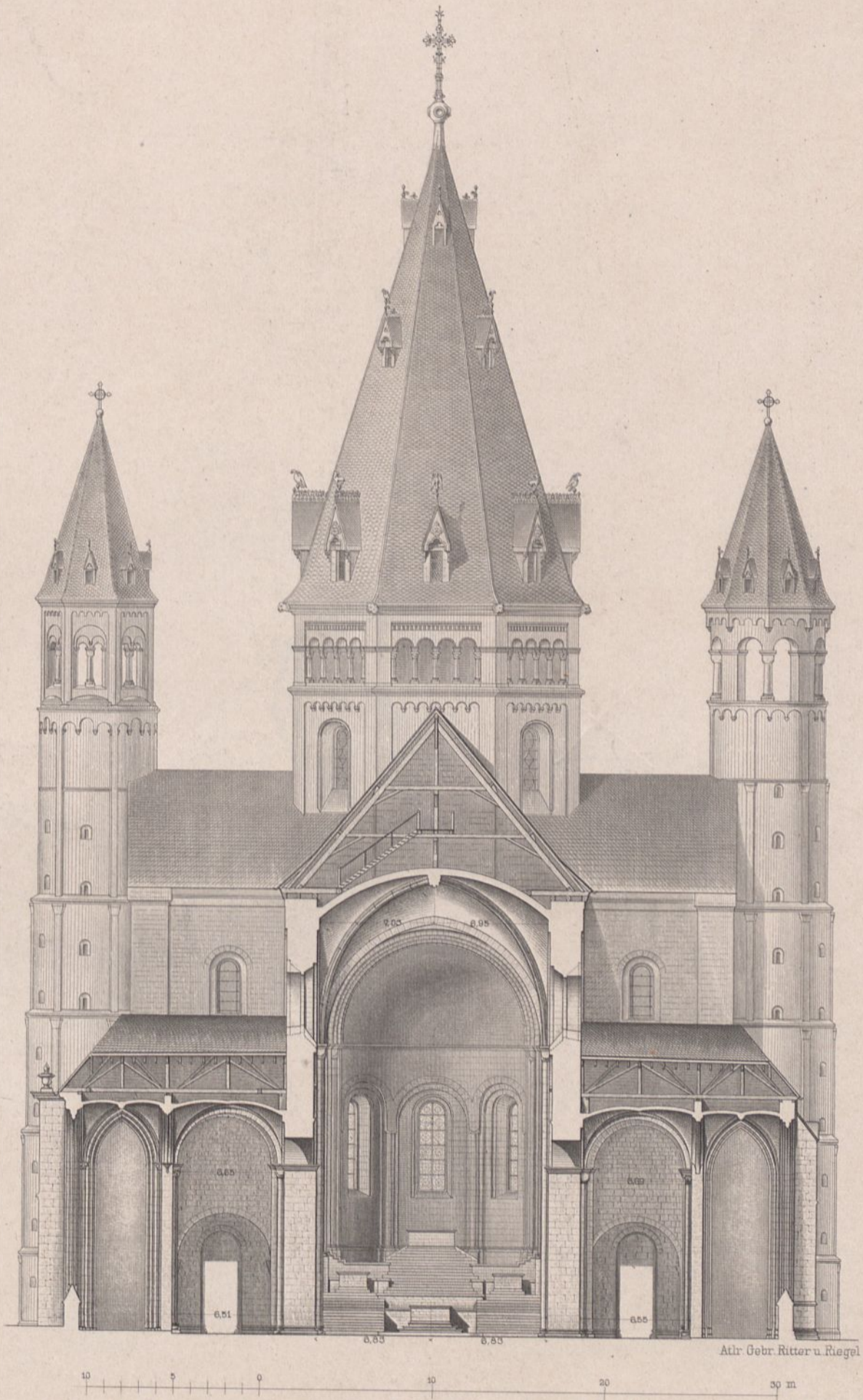

Dom zu Mainz.

Ostbau, heutiger Zustand.

Querschnitt durch das II. Joch des Schiffes v. O.

Ernst & Korn. Berlin.

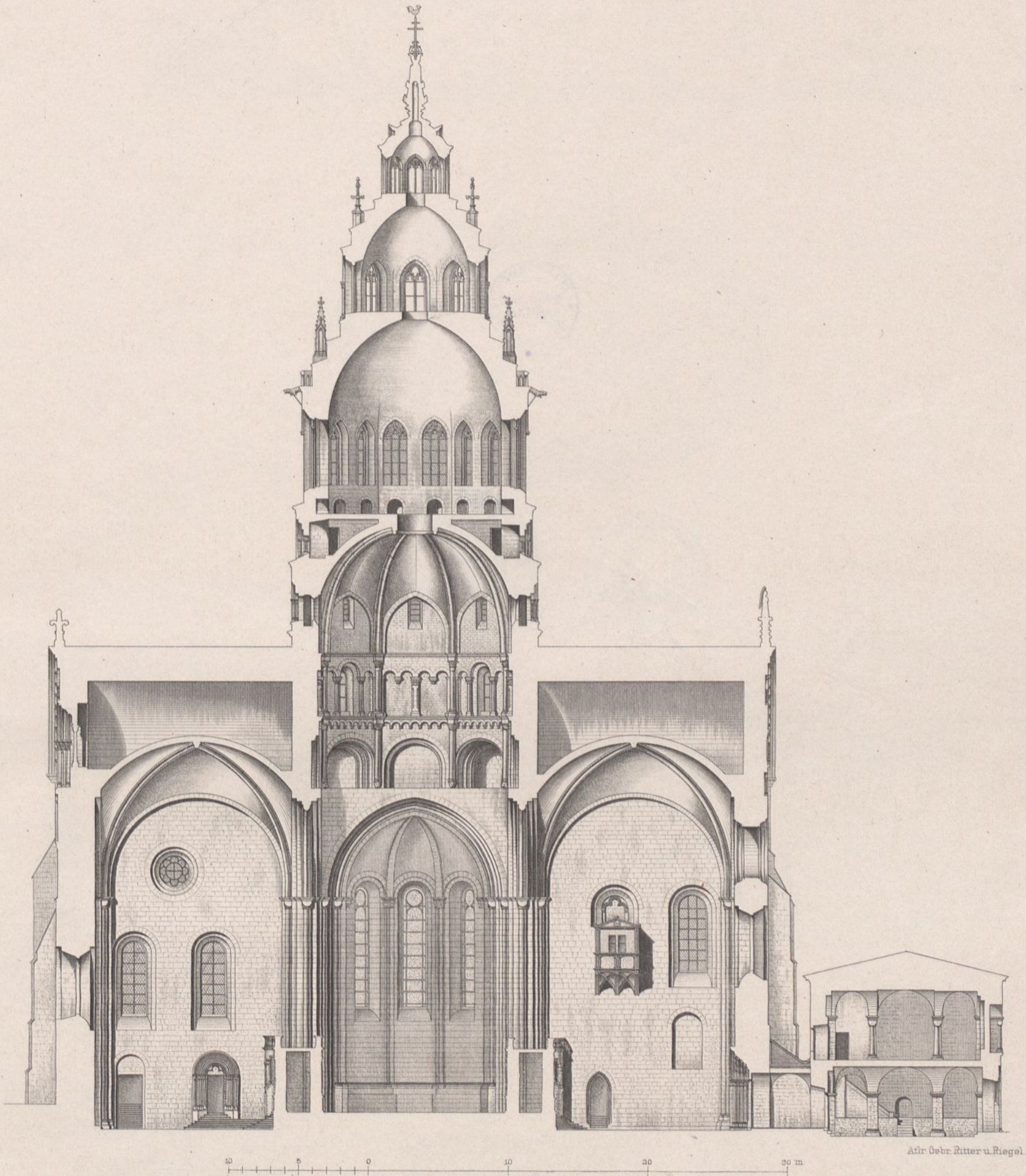

Dom zu Mainz.

Längenschnitt des westlichen Querschiffes
mit der Gothardecapelle.

Ernst & Korn. Berlin.

Krypta des Ostchores nach ihrer Wiederherstellung.

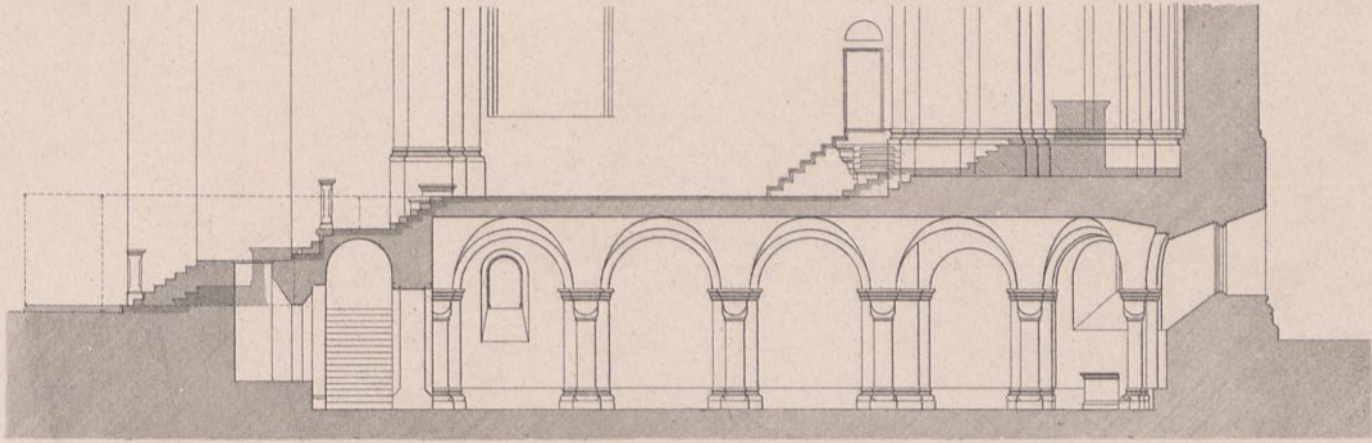

Längenschnitt.

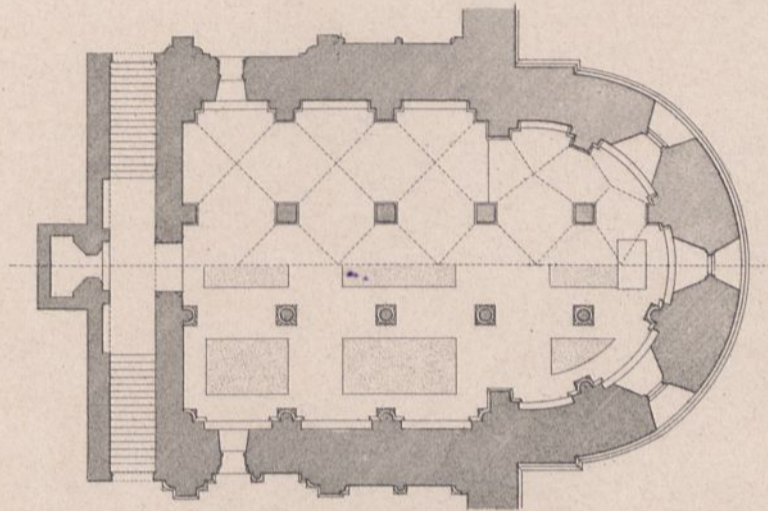

Grundriss.

Gothardcapelle.

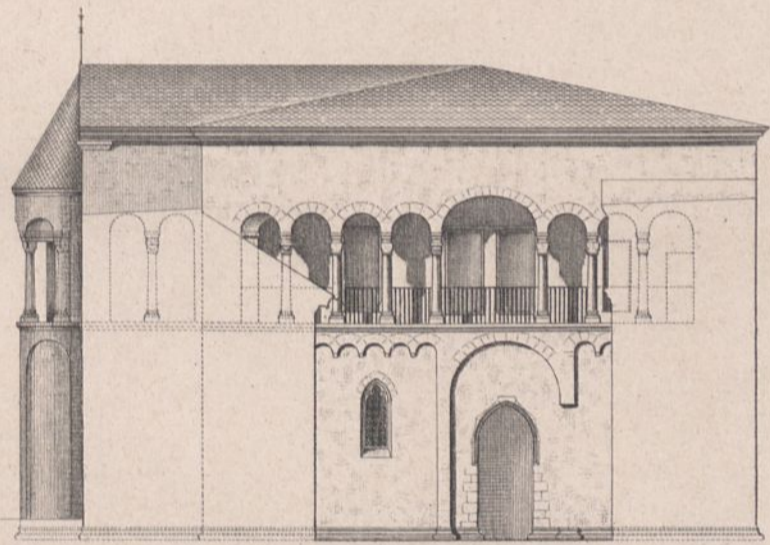

Ansicht der Nordseite.

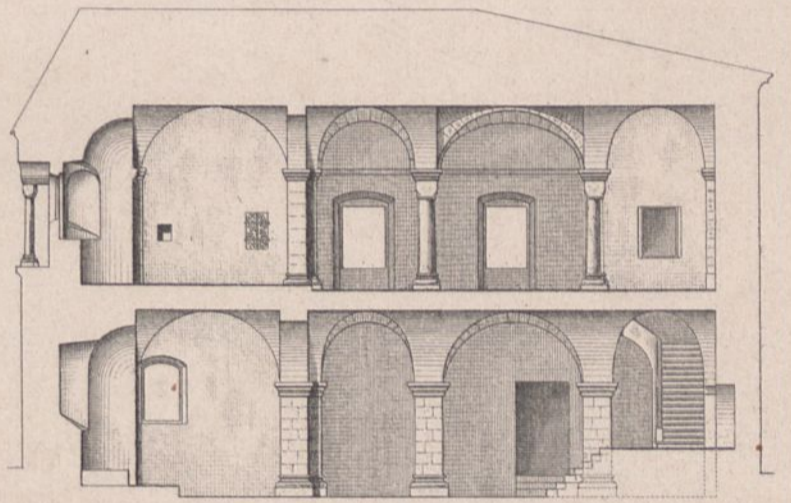

Längenschnitt.

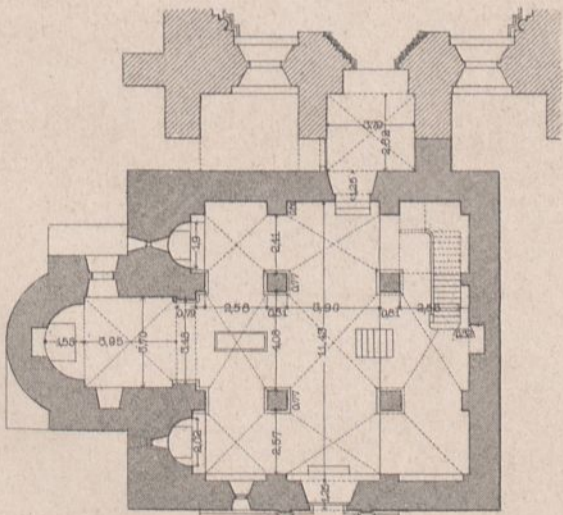

Unteres Geschoss.

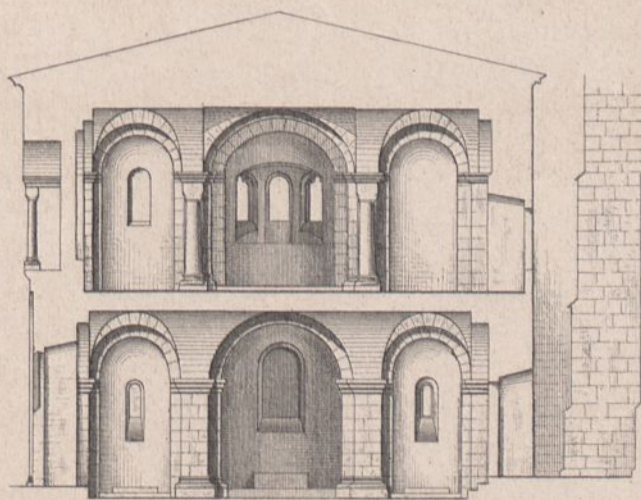

Querschnitt.

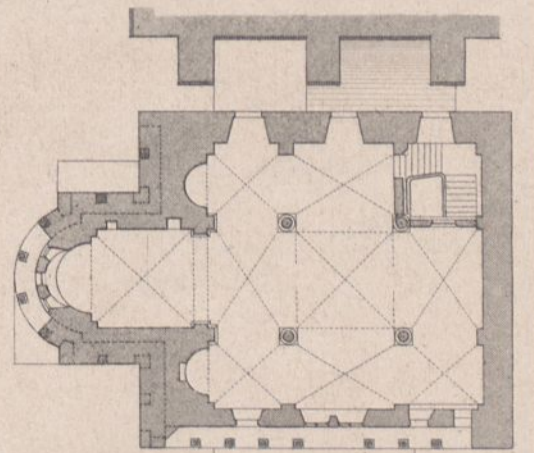

Oberes Geschoss.

10 0 0 10 20 m
für d. Grundrisse

10 0 0 20
für Ansicht und Durchschnitte

Atlr Gebr Ritter u. Riegel.

Kaiser Wilhelms-Universität Strassburg.
Physikalisches Institut.



H. Eggert, Arch.

Walther gest.

Ernst & Korn Berlin.

Kaiser Wilhelms-Universität Strassburg.

Physikalisches Institut.

Erdgeschoss.

- 1-11 Zimmer für Präcisionsarbeiten
- 1-4 " " " Optik, 7-10 eisenfrei
- a' Platten auf den isolirten Pfeilern
- b Platten auf den Gewölben, vom Fussboden isolirt
- c In die Wand gemauerte Steinconsolen
- d Digestorien
- ik Durch den Gasmotor getriebene Vorgelege.

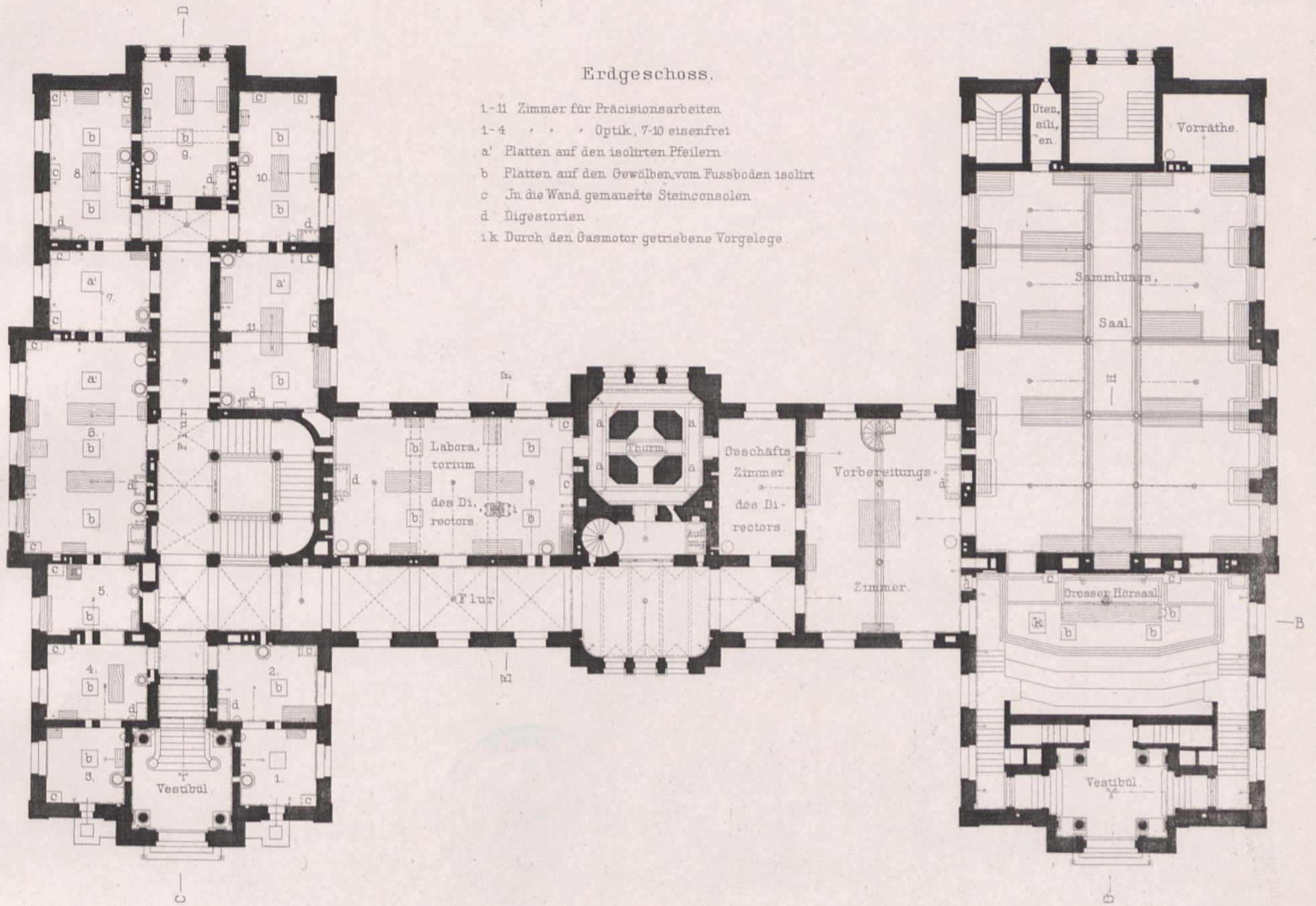

Kellergeschoss.

- x Eingang zum Raum für constante Temperatur unterhalb des Kellers
- a Isolirte Pfeiler
- l Drehbank
- m Grammesche Maschine
- n Gasmotor

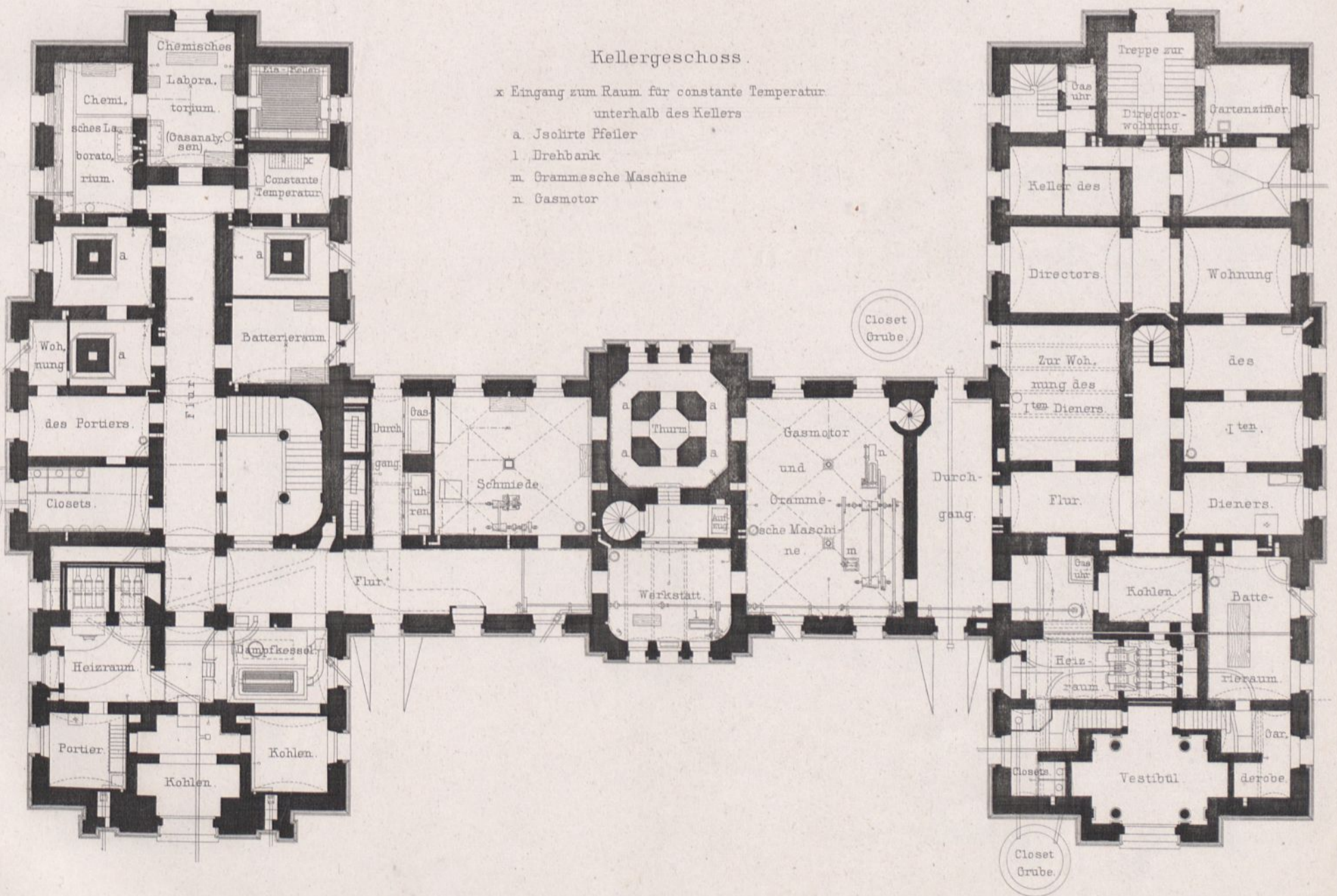

0 5 10 15 20 25 30 m.

Kaiser Wilhelms-Universität Strassburg.

Physikalisches Institut.

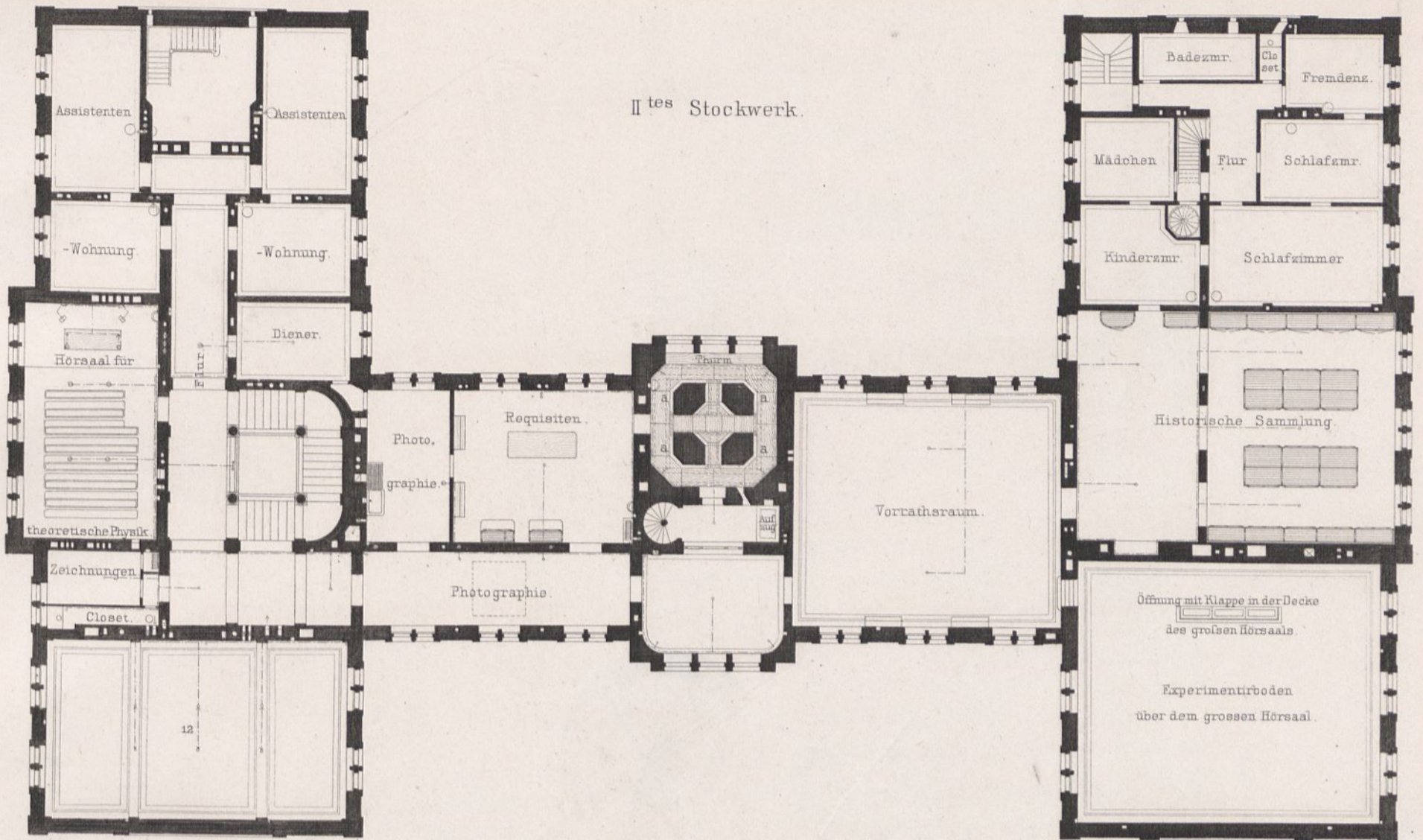

IItes Stockwerk.

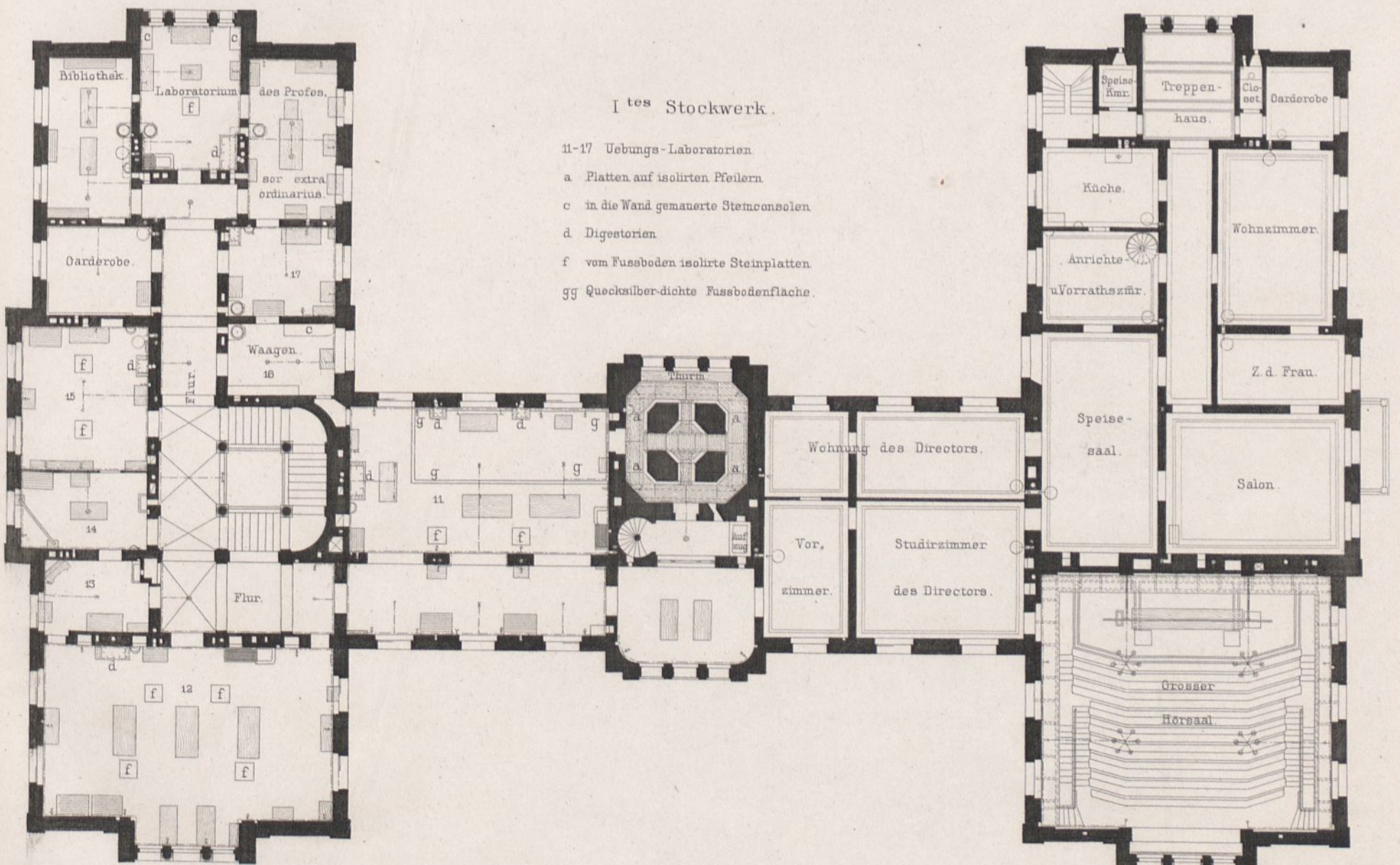

Ites Stockwerk.

- 11-17 Uebungs-Laboratorien
- a Platten auf isolirten Pfeilern
- c in die Wand gemauerte Stempconsolen
- d Digestorien
- f vom Fussboden isolirte Steinplatten
- gg Quecksilber-dichte Fussbodenfläche.

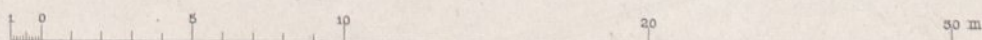

Kaiser Wilhelms-Universität Strassburg.

Physikalisches Institut.

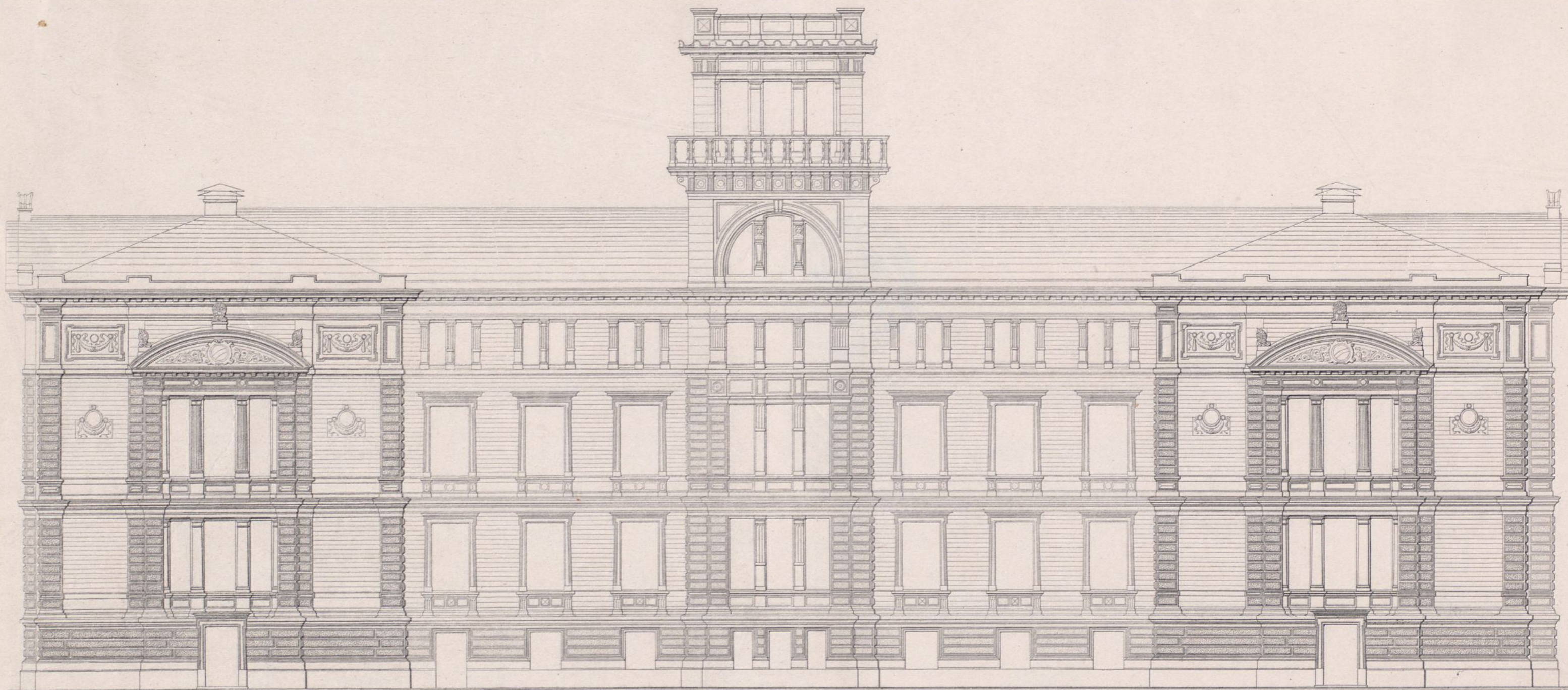

H. Eggert, Arch.

Walther gest.

Ansicht der Nordseite.

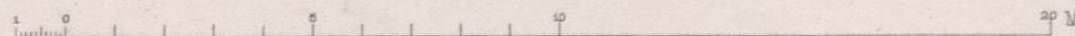

Ernst & Korn. Berlin.

Kaiser Wilhelms-Universität Strassburg.

Physikalisches Institut.

Längenschnitt A-B.

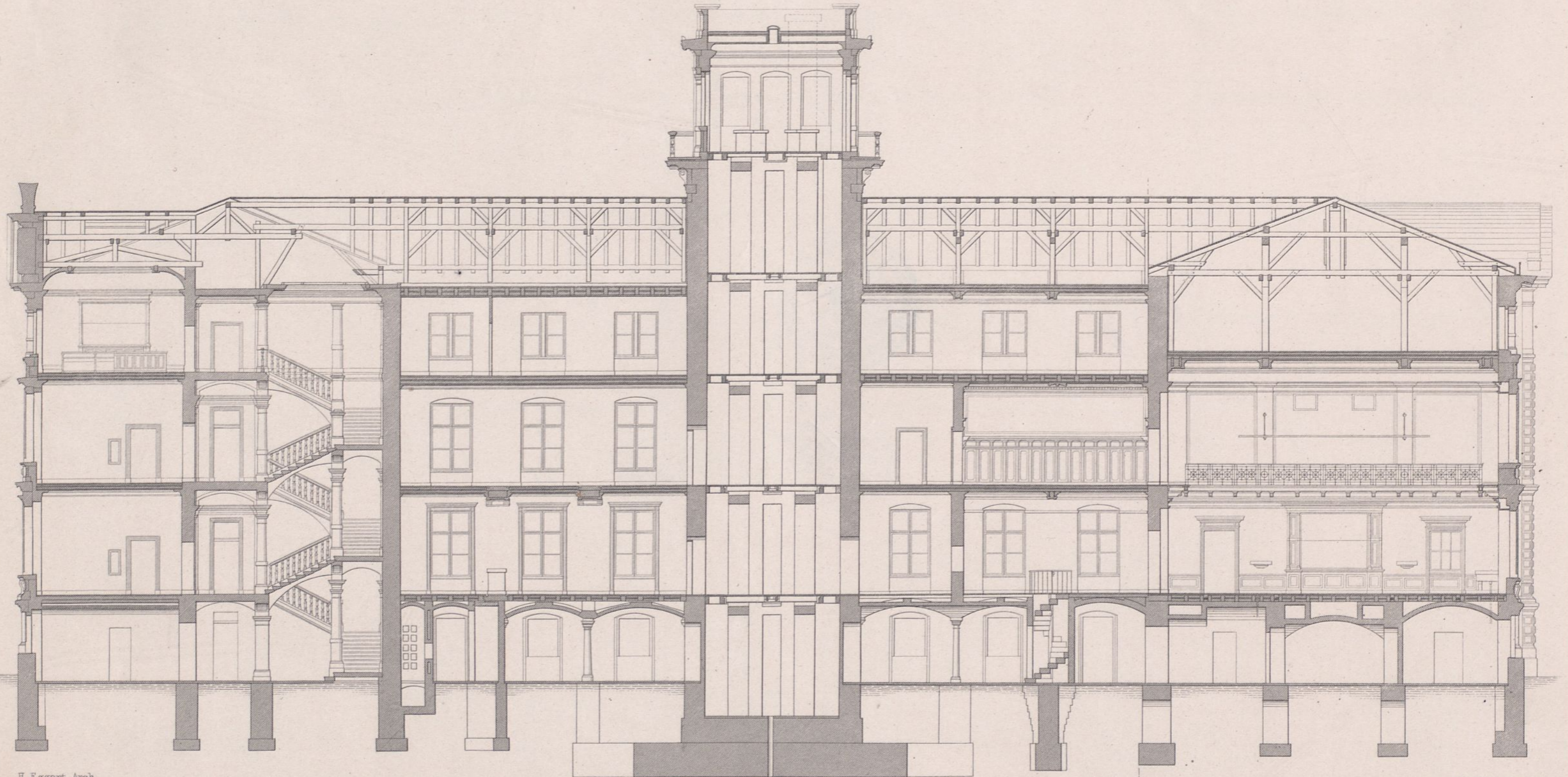

H. Eggert, Arch.

Walther gest.

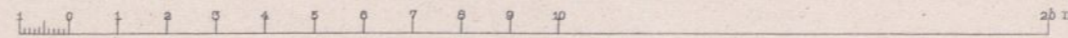

Ernst & Korn, Berlin.

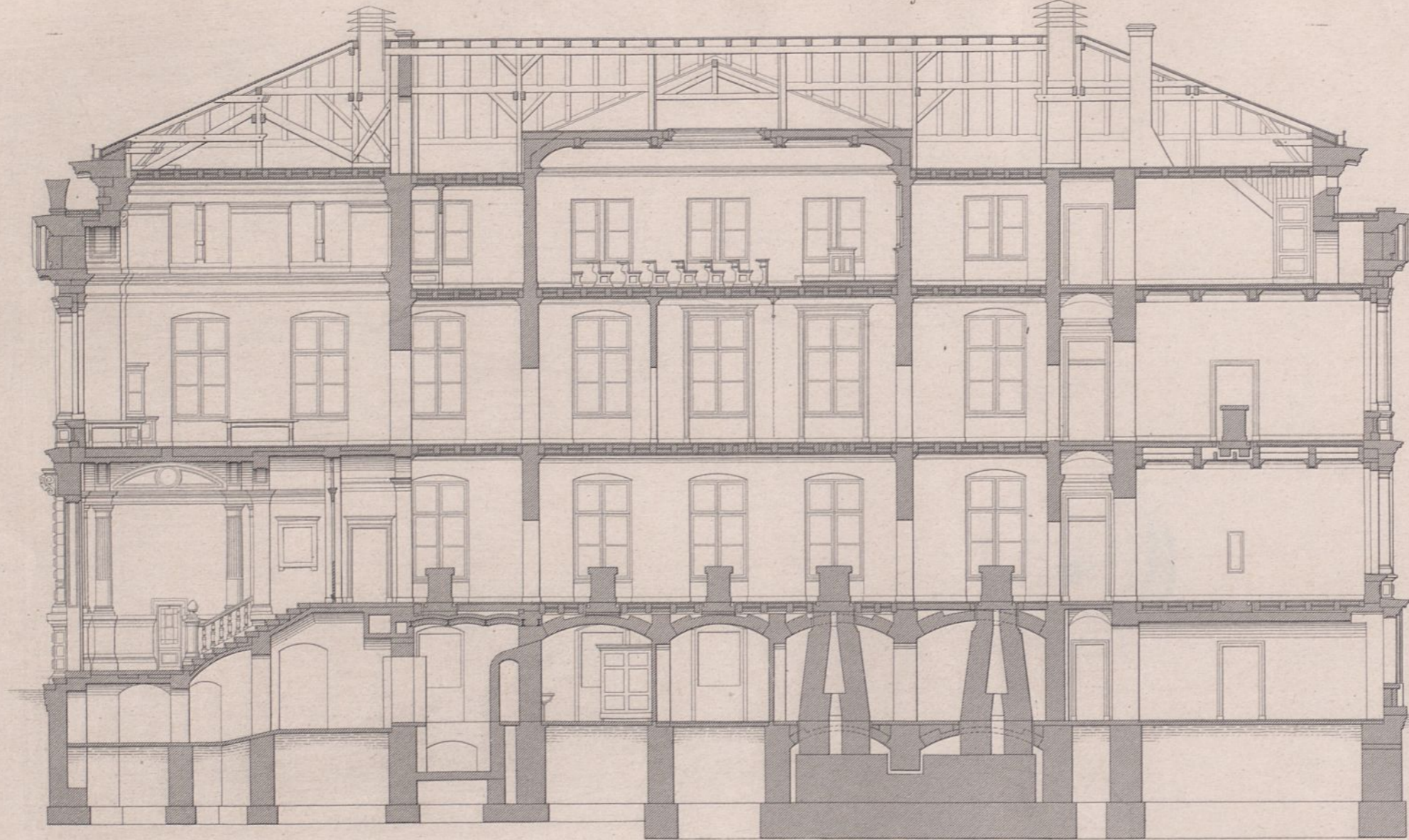

Längenschnitt CD durch d. westl. Flügel.

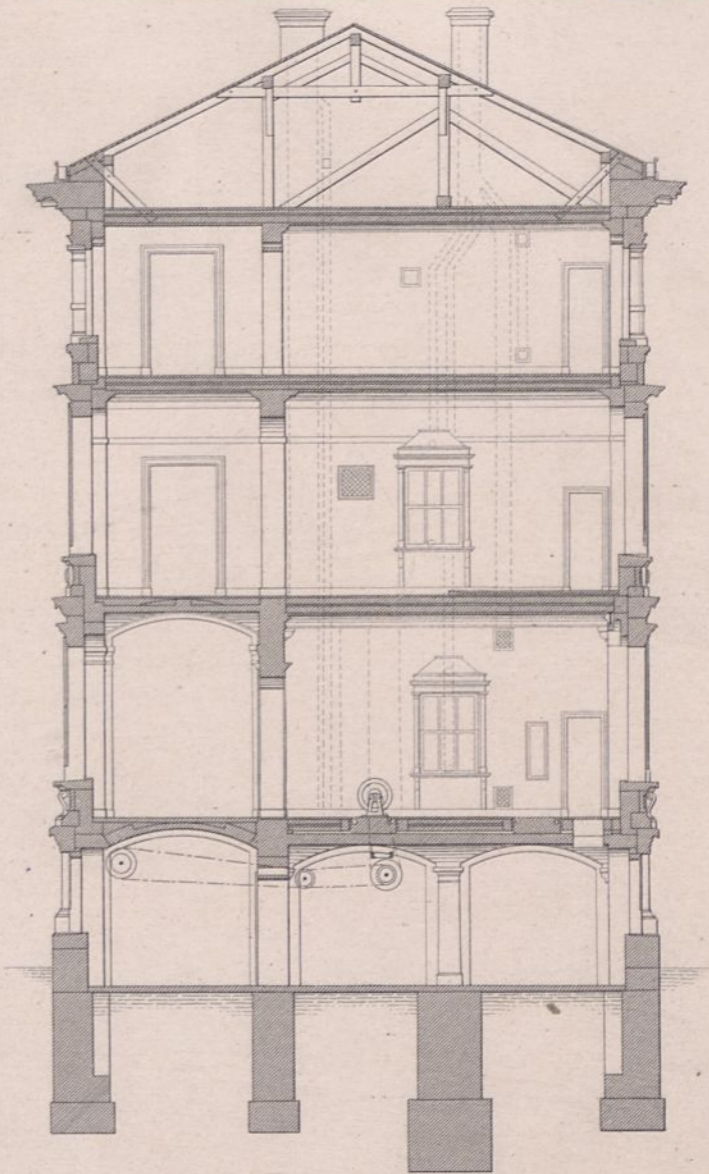

Schnitt E F durch d. Zwischenbau.

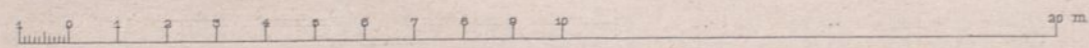

Detail des Quecksilberdichten Bodens.

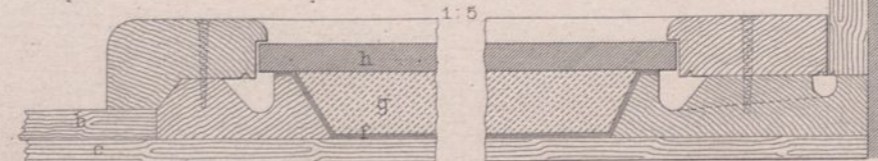

Quecksilberdichter Boden im Übungs-
laboratorium N° II im I. Stock.

- f Asphaltpappe
- g Cementbeton
- h Metallacher
Platten.

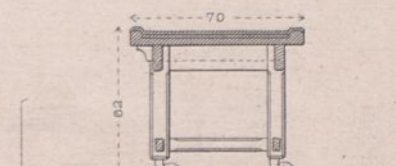

Tisch zum Aufstellen galvanischer
Batterien.

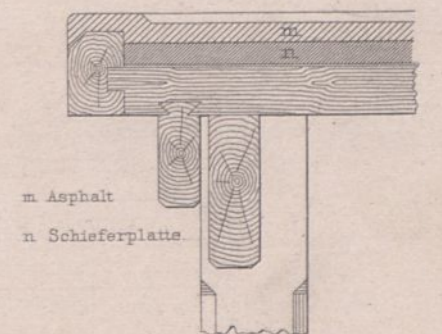

- m Asphalt
- n Schieferplatte.

Walther gest.

Detail der Quecksilberrinne 1:5.

Vom Fussboden

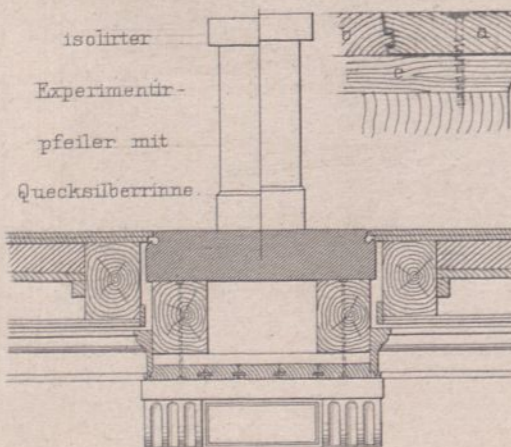

- a Abnehmbarer Rahmen
- b Riechler Stabfussboden
- c Blindboden
- d Dicke Papplage
- e Steinplatte.

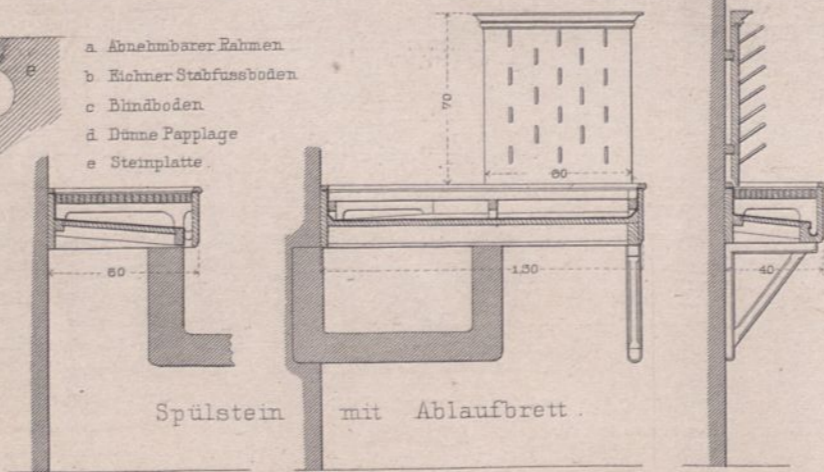

Spülstein mit Ablaufbrett.

H. Eggert. Arch.

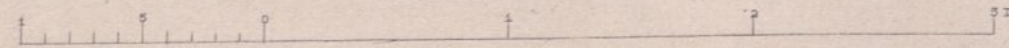

Ernst & Korn. Berlin.

Physikalisches Institut.

Längenschnitt G H durch den östlichen Flügel.

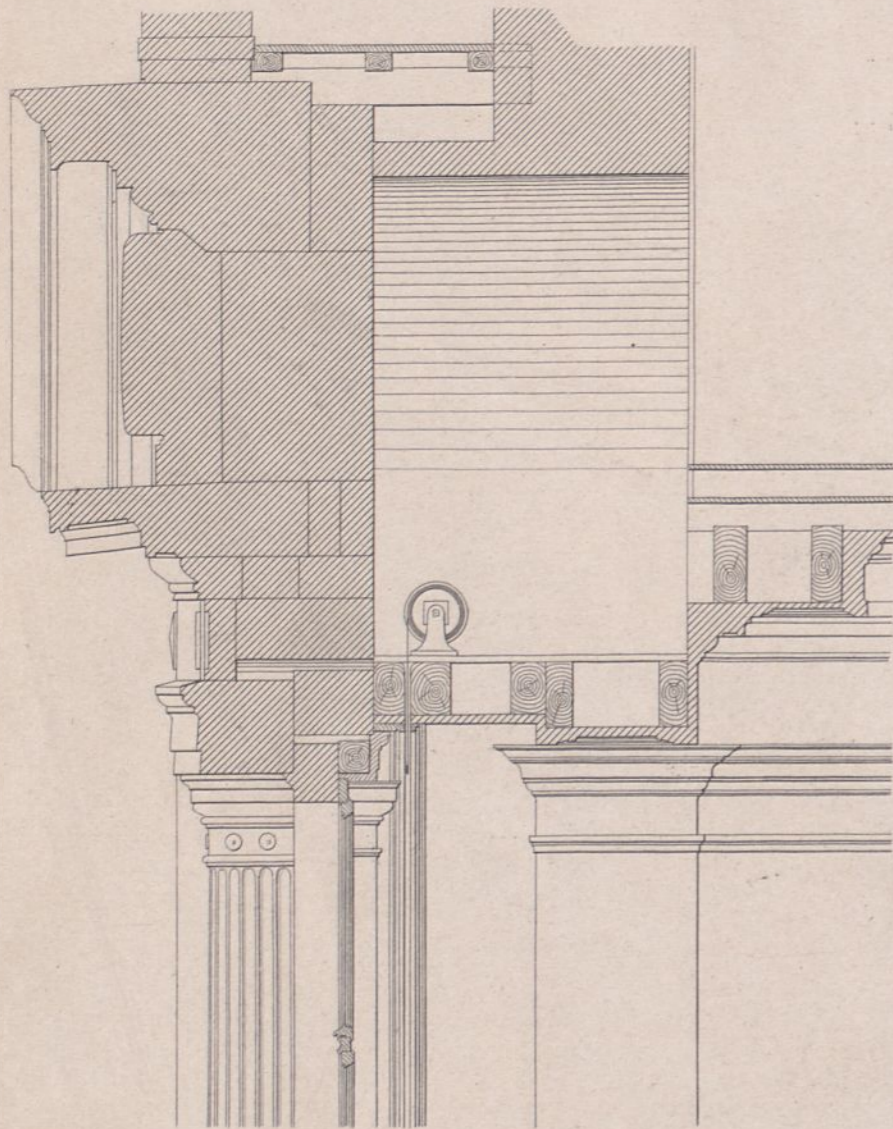

Schnitt durch das südliche gekuppelte Fenster im grossen Hörsaal.

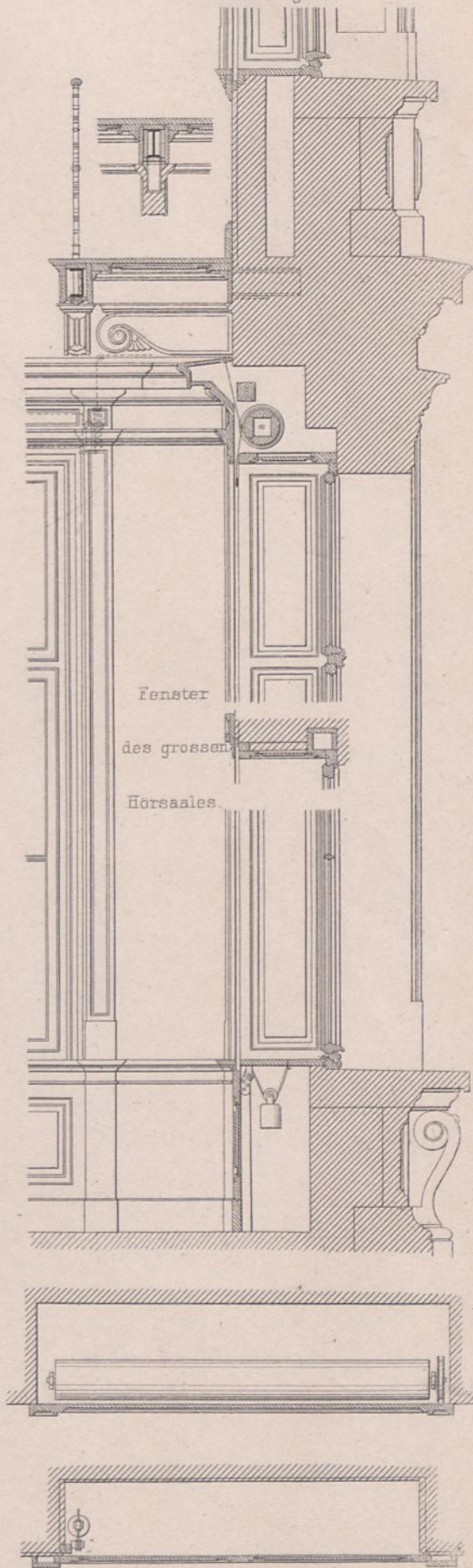
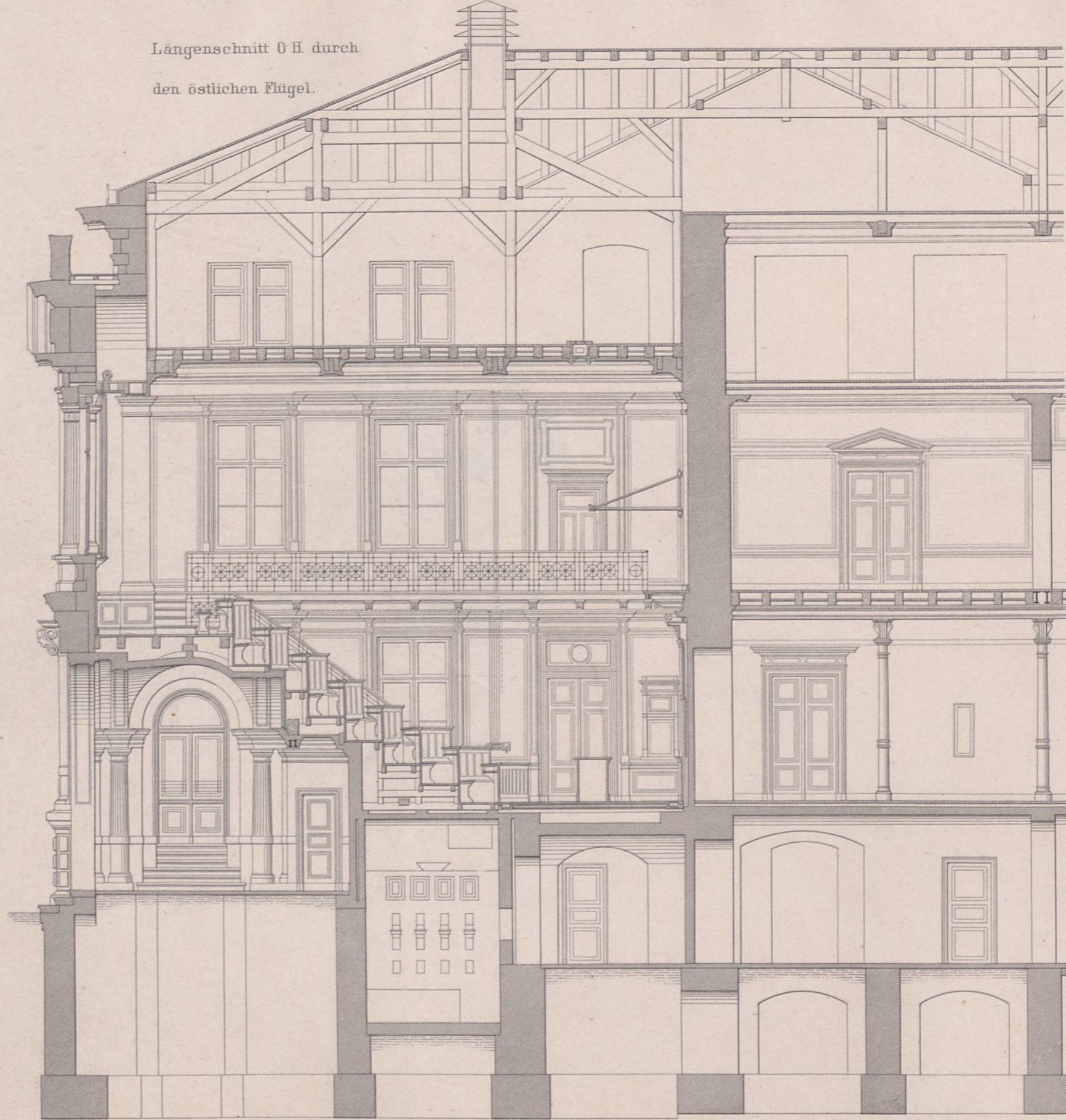
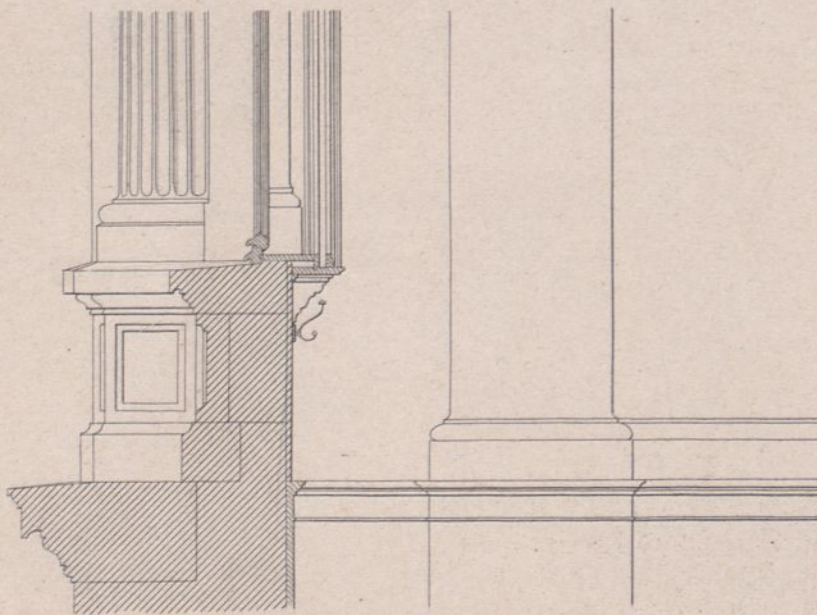

Fenster des grossen Hörsaales.

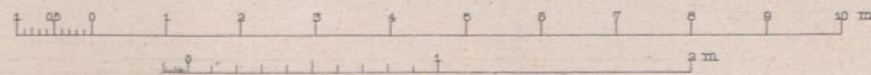

Aussteigeluhe zur Thurmplattform.

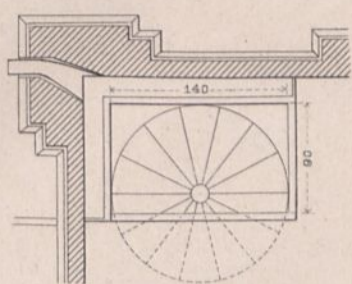

Thurmplattform - Querschnitt.

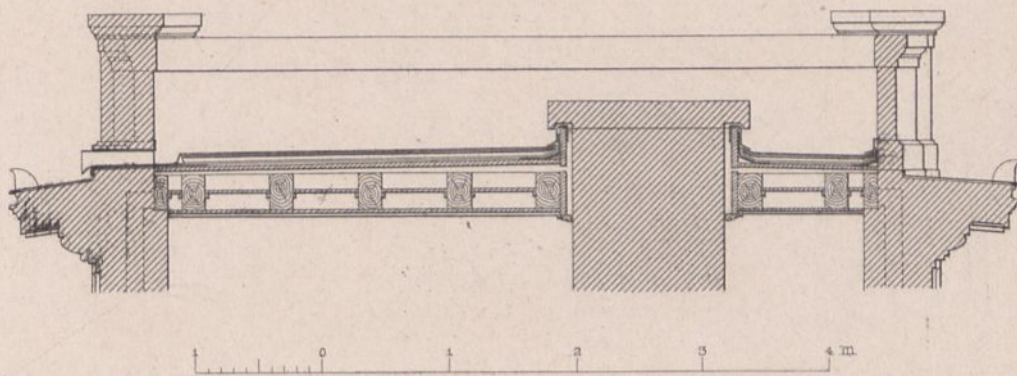

Aussteigeluhe - Querschnitt.

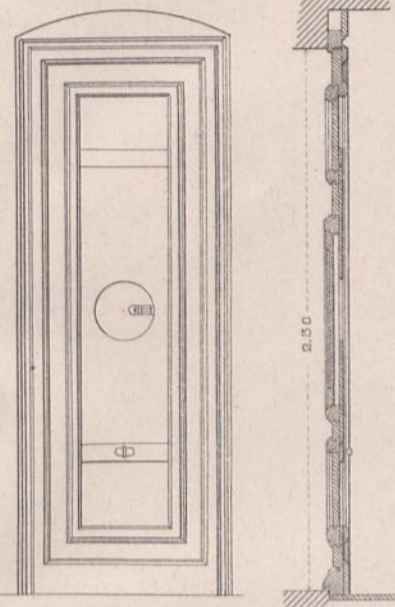
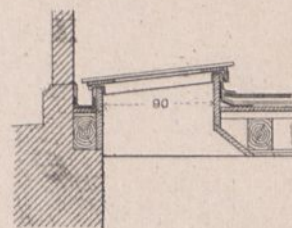

Thür mit Schlitz in d. Zimmern für Optik
Nº 1-4 im Erdgeschoss.
Ausgang zu den Heliostaten-Pfeilern.

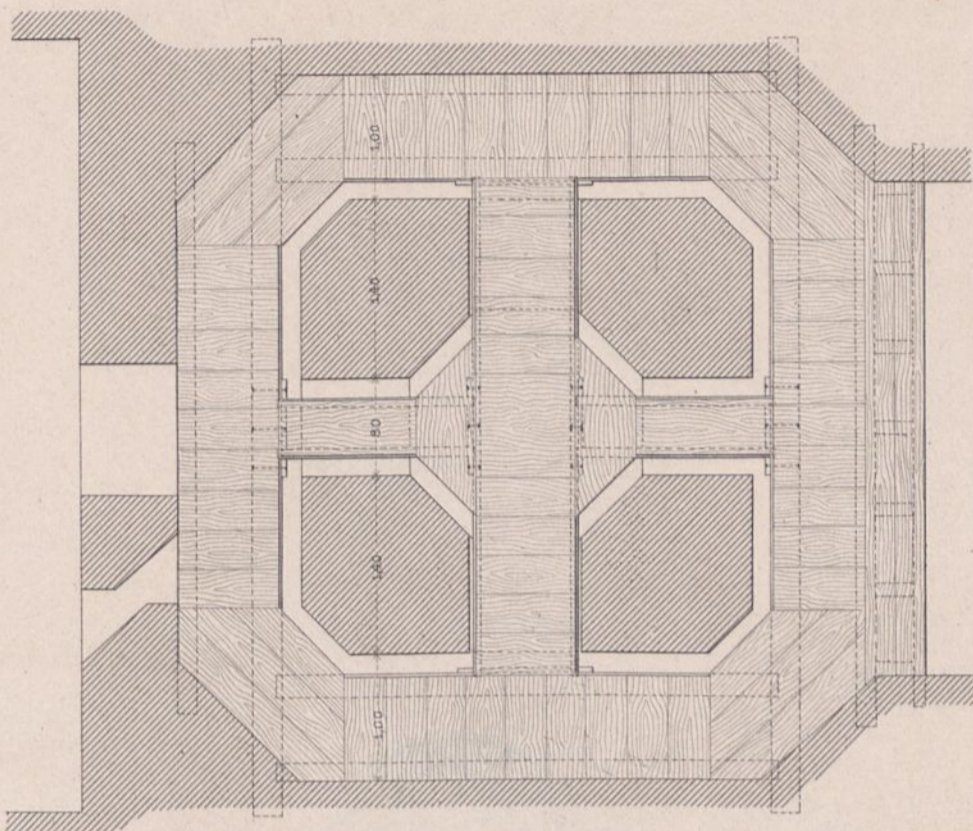
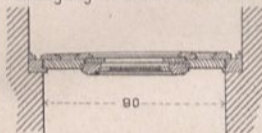

Construction des Fussbodens der Stockwerke im Thurm.

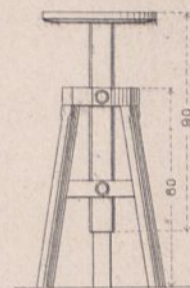
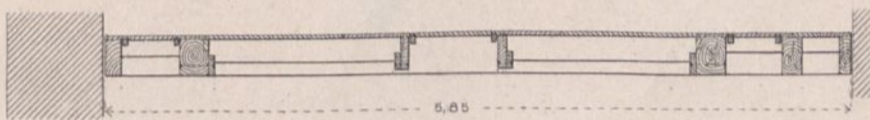

Stativ zur Aufstellung der
Instrumente pp.

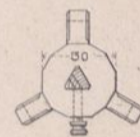

Gelenkverbindung
an der Trägerschiene

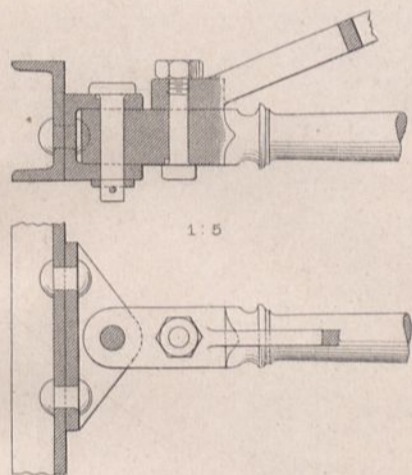

Seitlich zu bewegende Trägerschiene
zur Aufhängung von Apparaten
über dem Experimentirtisch
im grossen Hörsaal

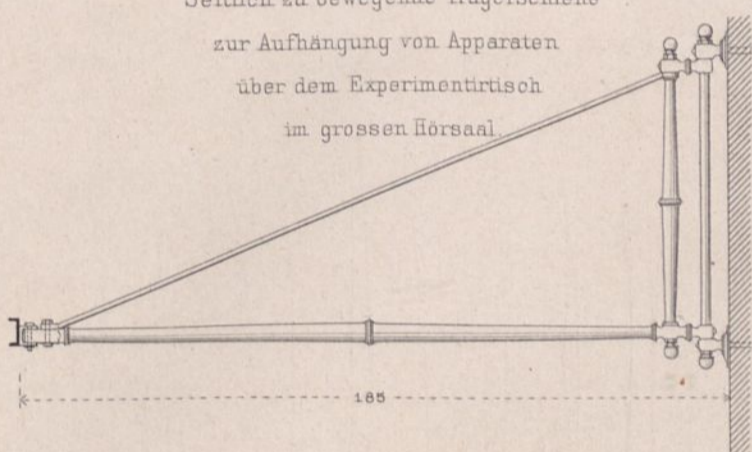

Gelenkverbindung an der Wand.

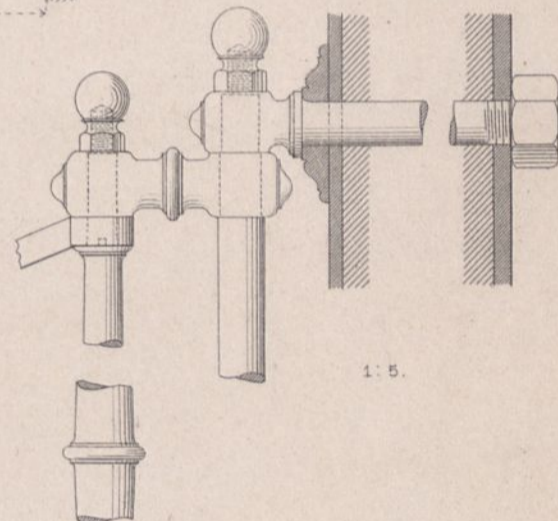

Bewegungsmechanismus für die gleichzeitige Verdunkelung
aller Fenster einer Saalseite im grossen Hörsaal.

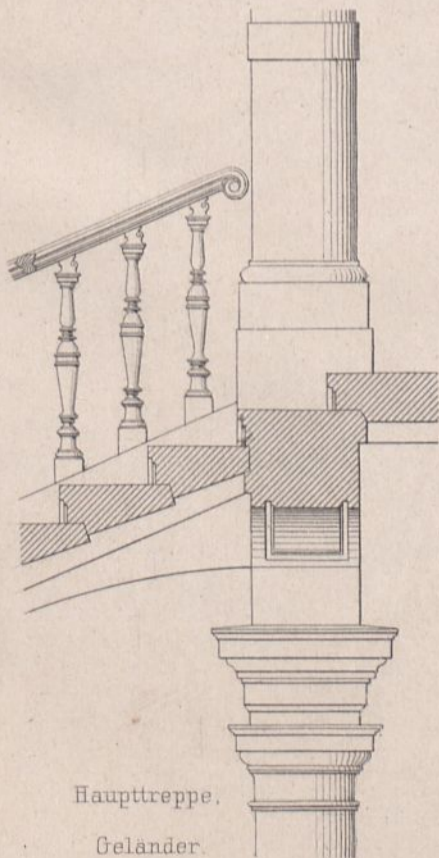
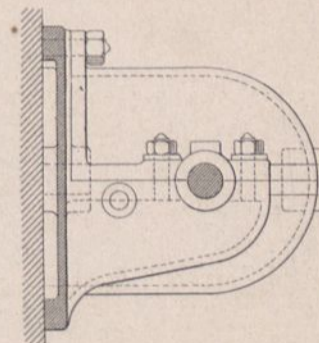
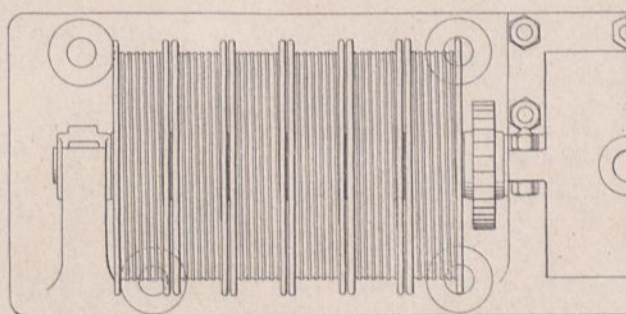

Haupttreppe.
Geländer.

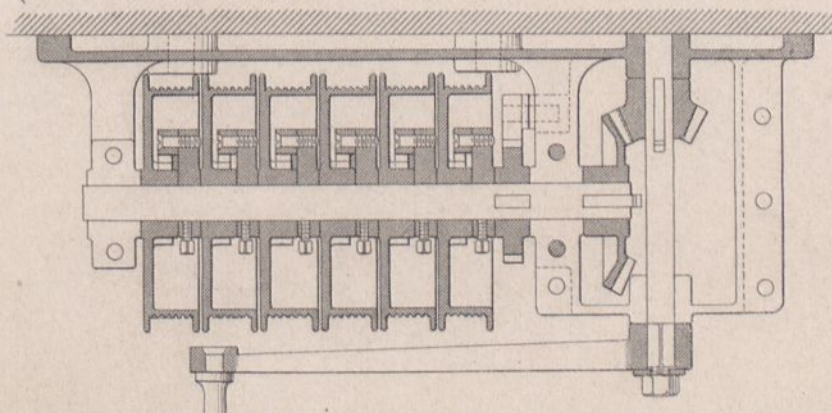

Vorrichtung

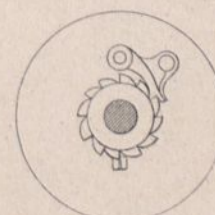

zum Nachspannen bzw. Regulieren
der einzelnen Seillängen.

Physikalisches Institut.

Schrank für Instrumente.
Seitenansicht.

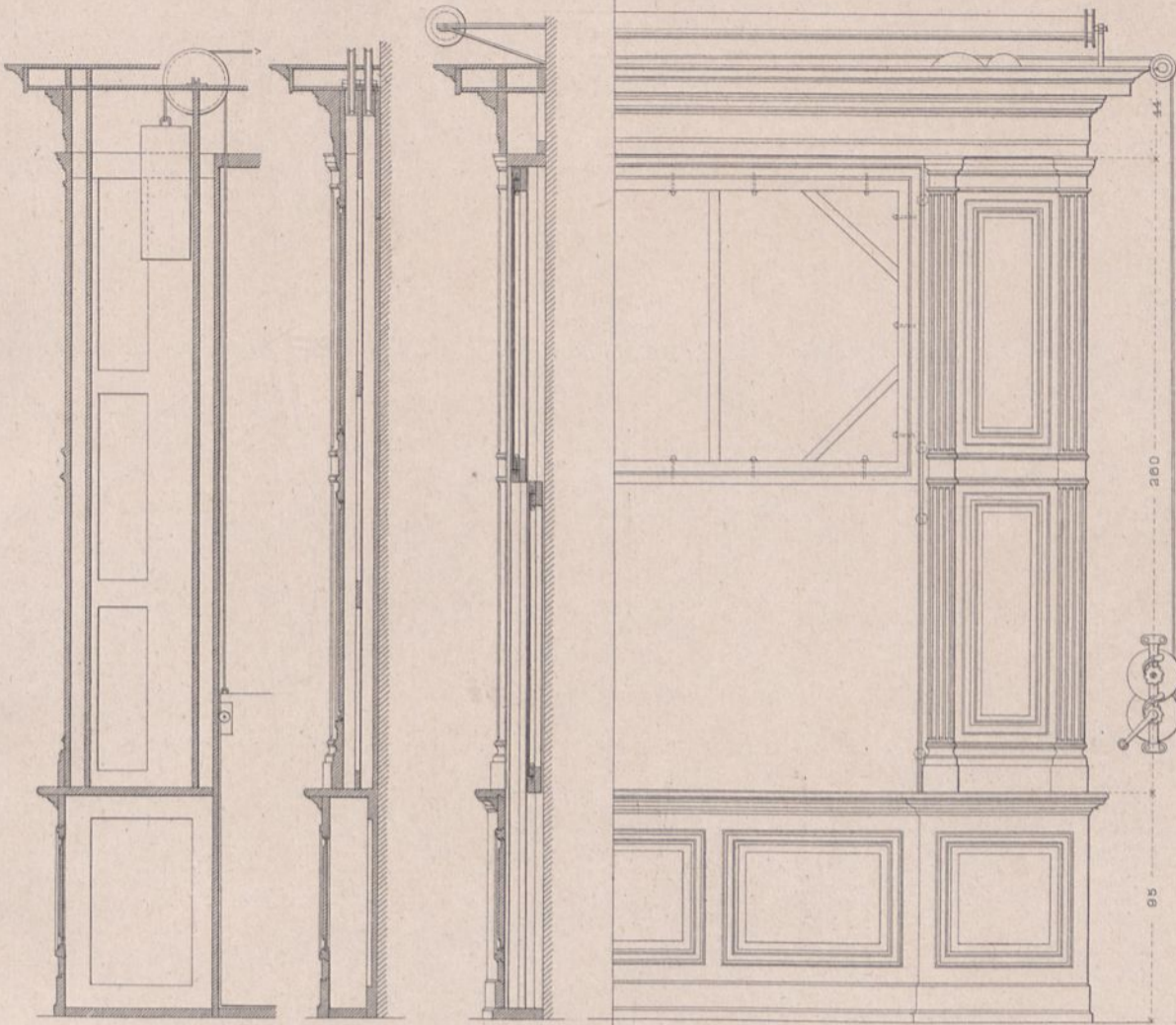
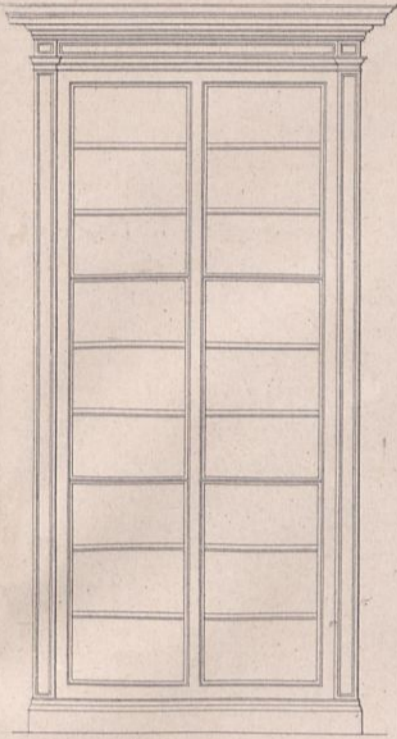

Schrank für Instrumente.
Querschnitt.

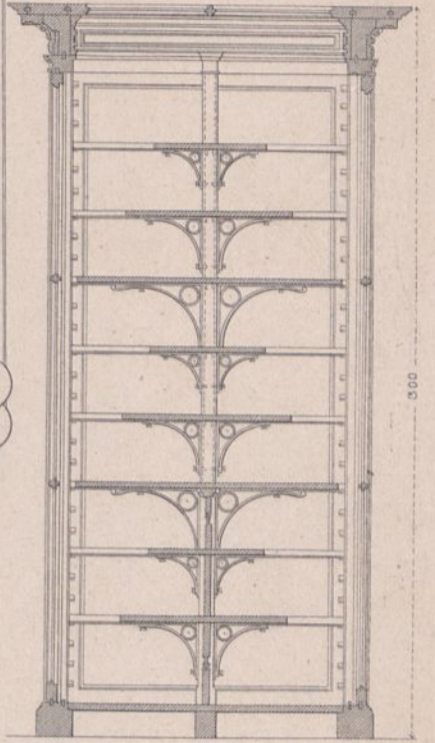

Bewegungs-
vorrichtung

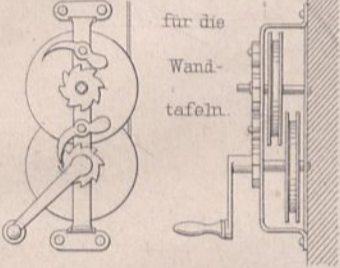

für die
Wand-
tafeln.

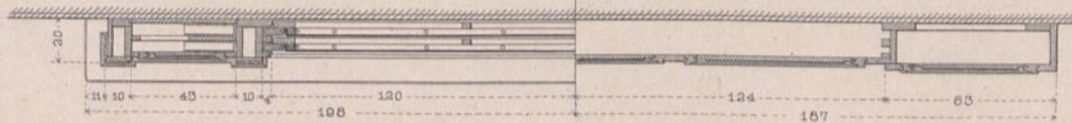

Wandtafel im grossen Hörsaal.

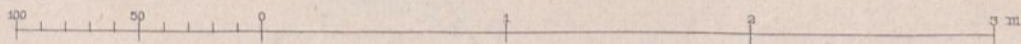

Experimentirtisch im grossen Hörsaal.

Quecksilberdichter Verschluss der Oeffnungen.

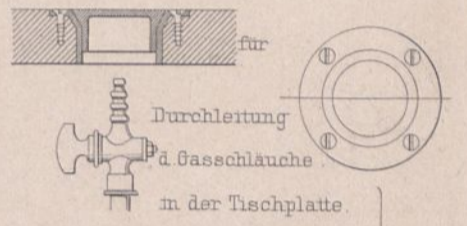

Durchleitung
d. Gasschläuche
in der Tischplatte.

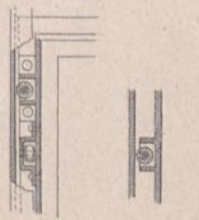
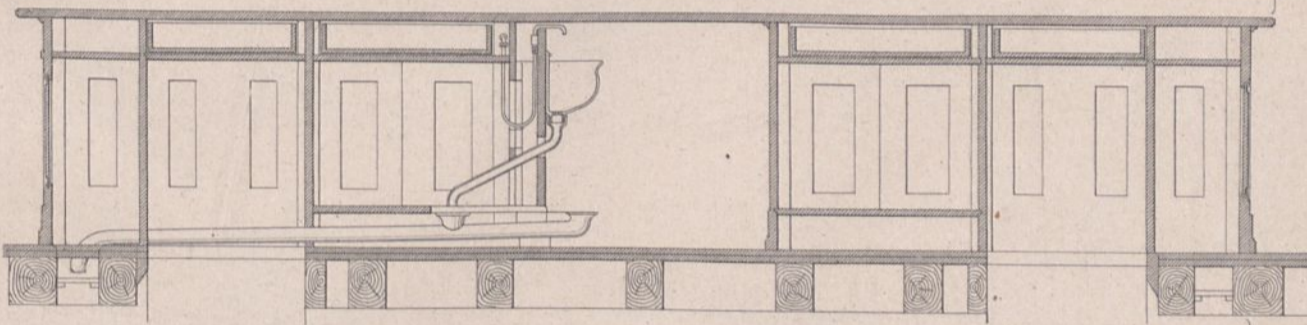
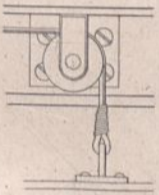
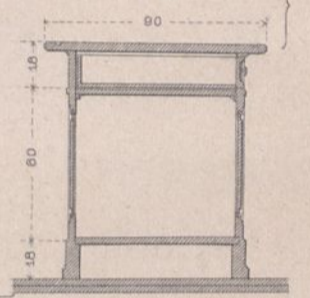
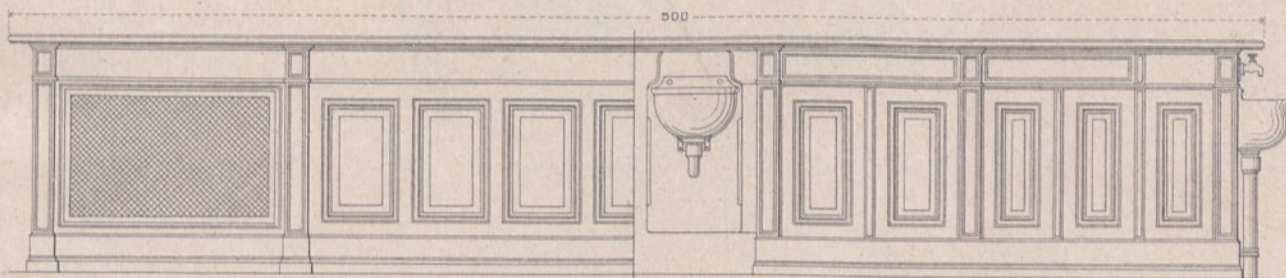
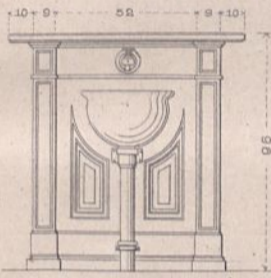

Ansicht von innen u. Verticalschnitt.

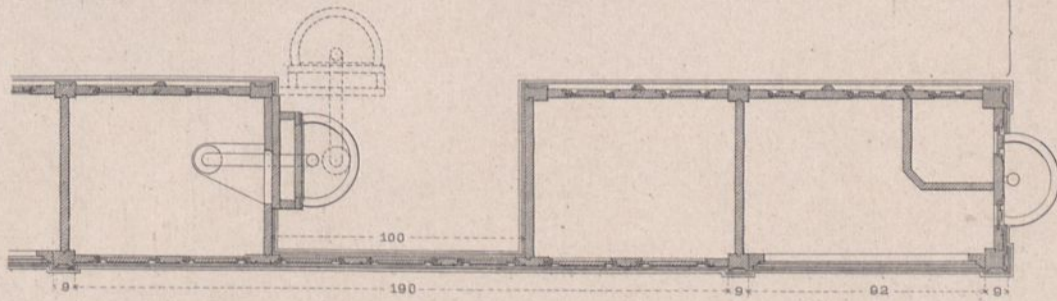
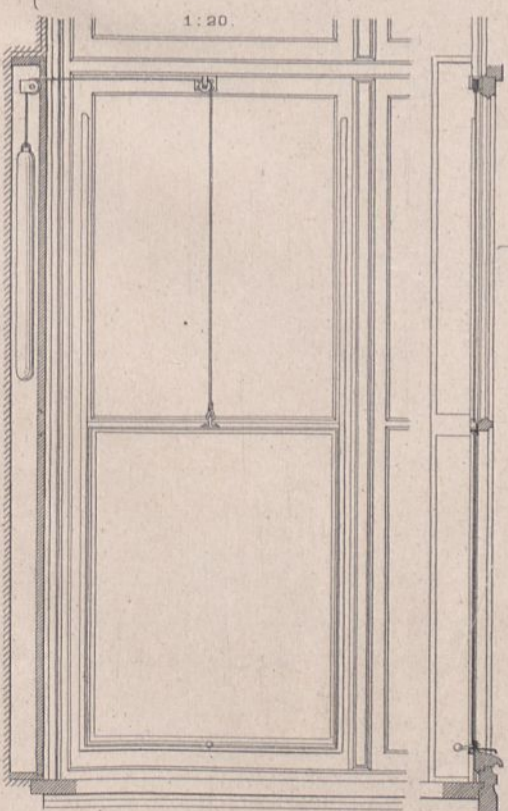

Bewegliche Scheibe in den Fenstern der Laboratorien.

Rollenführung des
Scheibenrahmens
in den Falzen.

1:5.

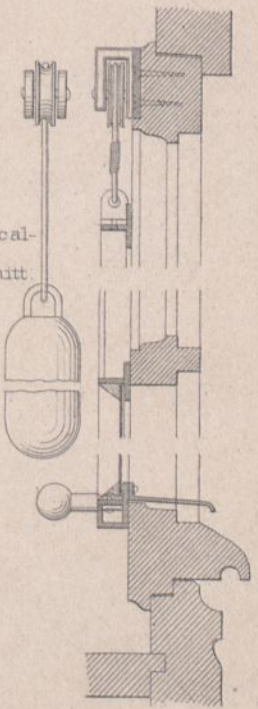

Vertical-
schnitt.

Horizontal-
schnitt.

Grundriss eines Schrankes für Instrumente.

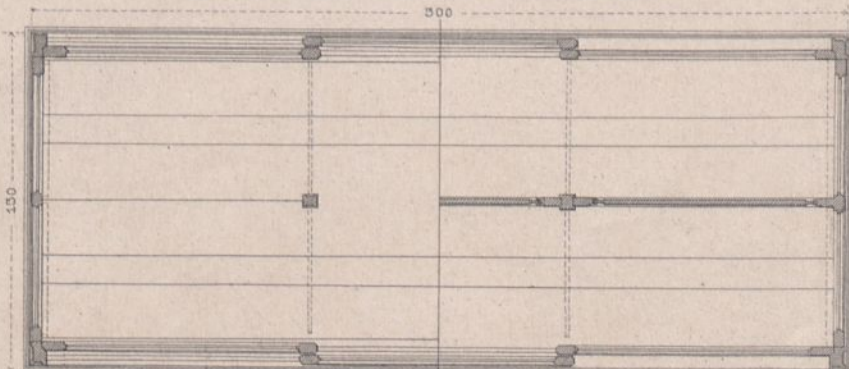

Situationsplan.

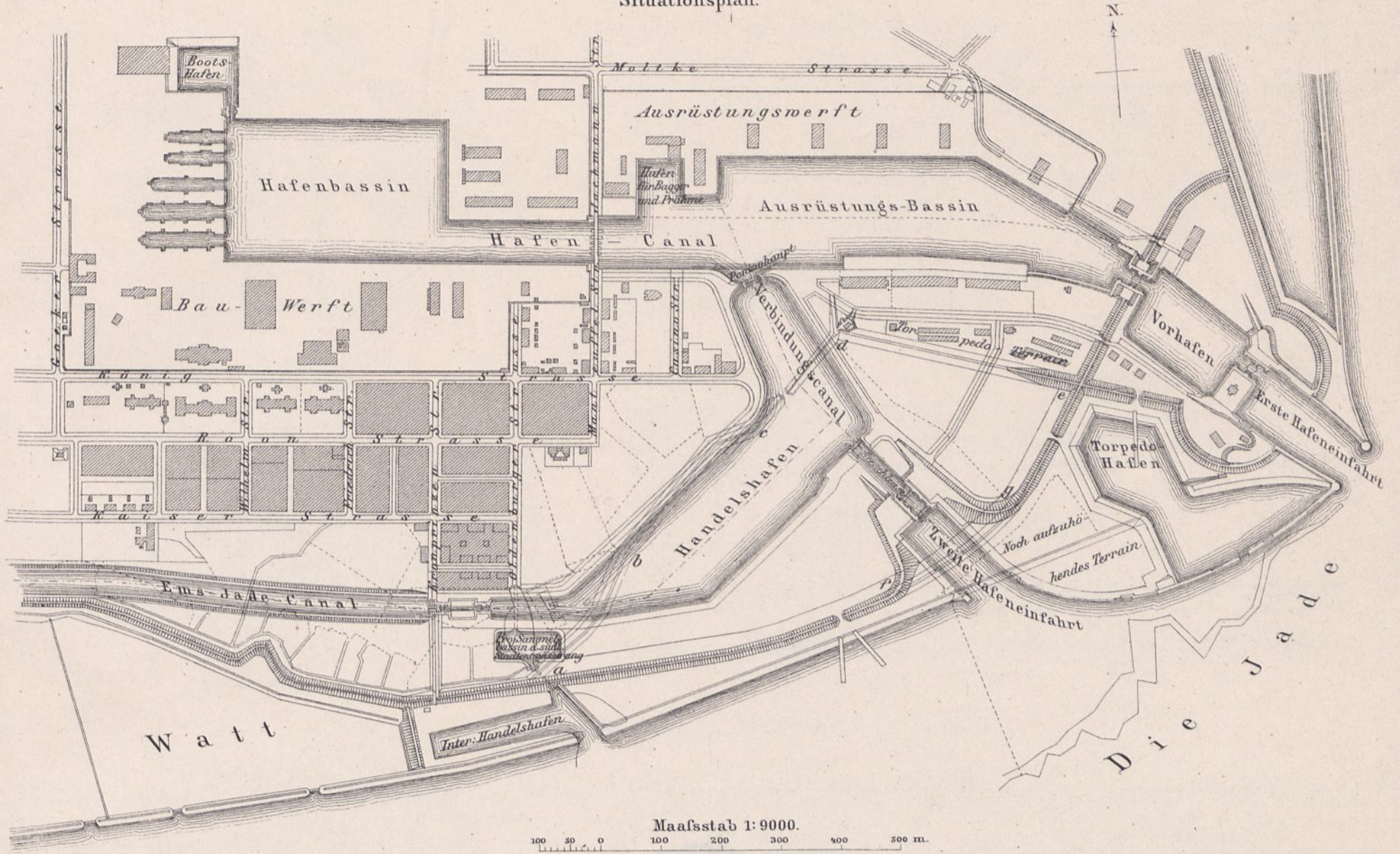

Baudispositionsplan.

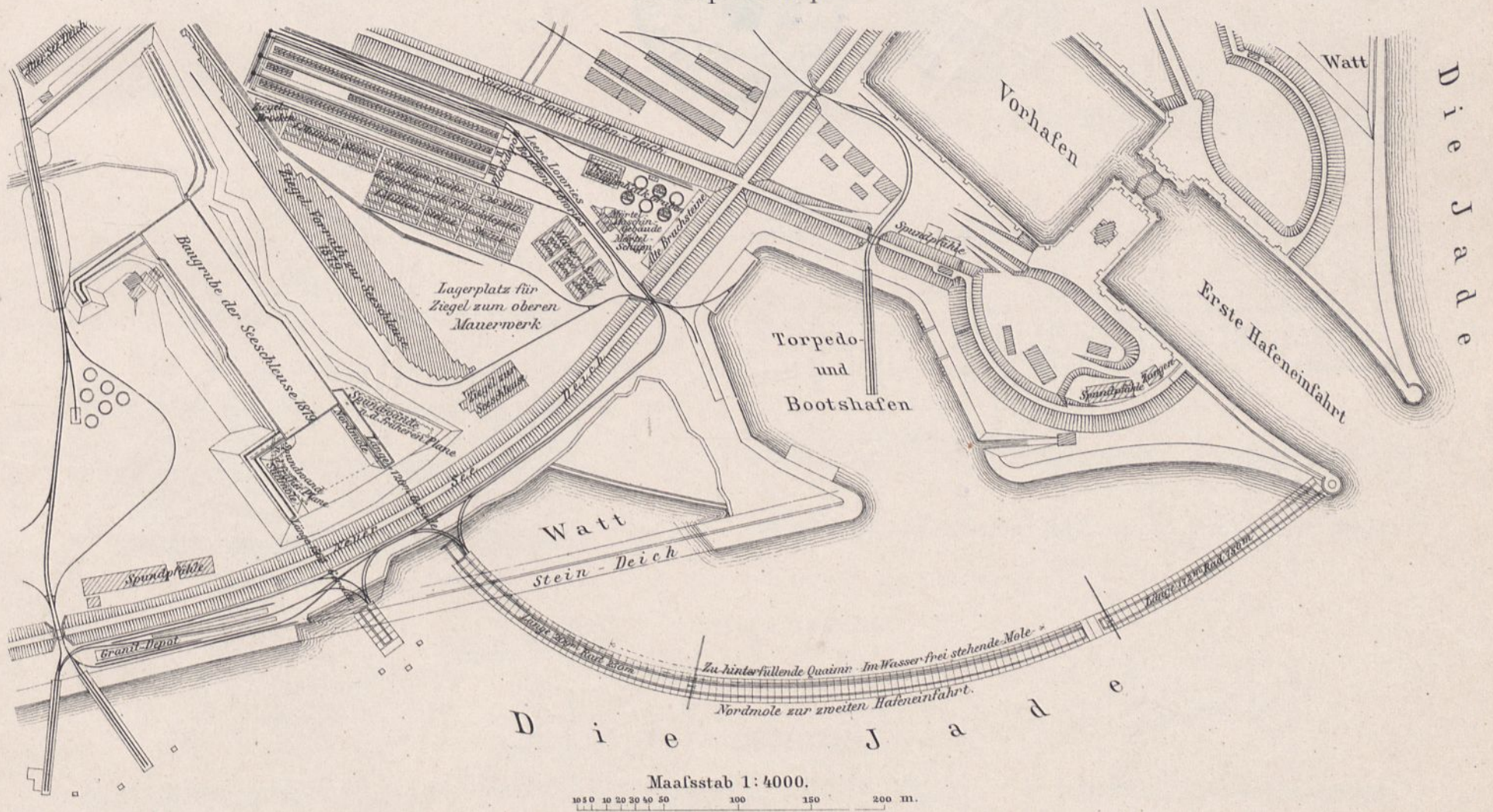

Mauerprofile.

Profil der Molenquaimauer aussendeichs.

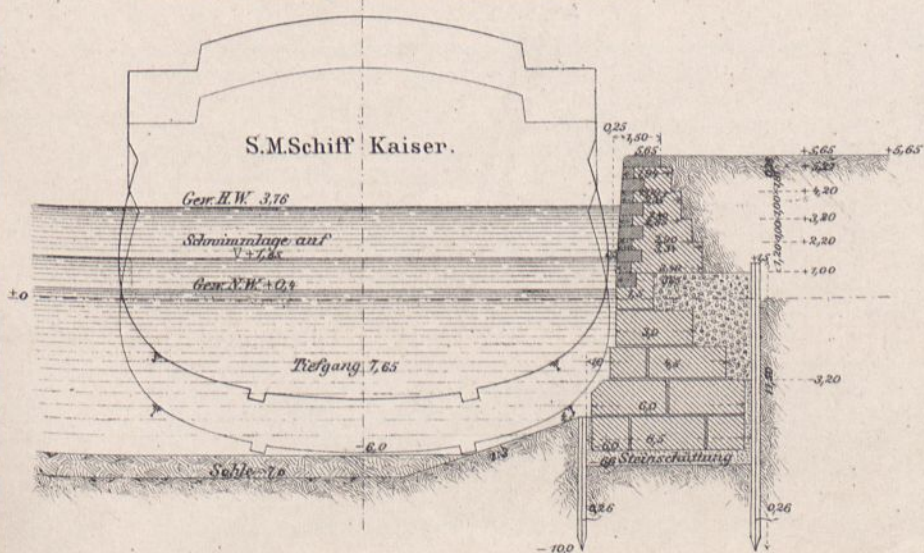

Profil der Mole.

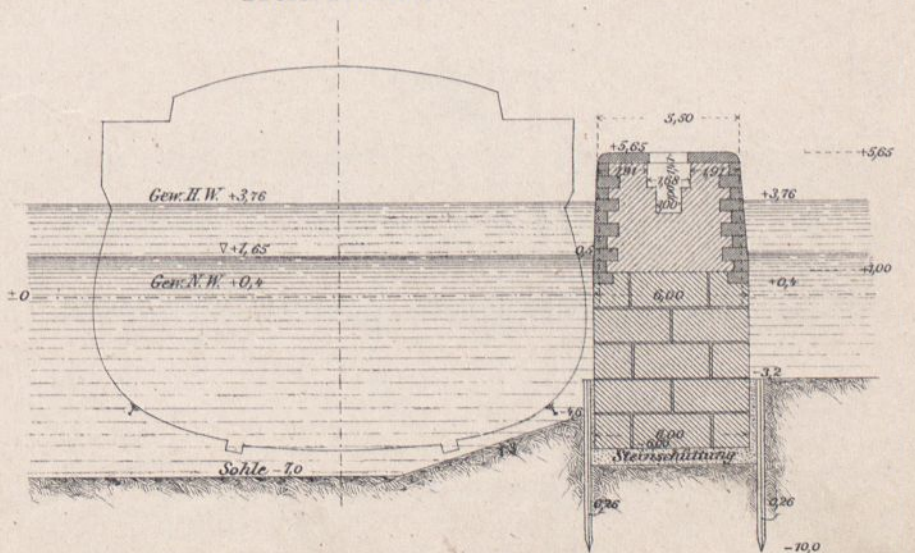

Wilhelmshaven.

Rüstungen zur Bauausführung. Ausbaggern der Baugrube.

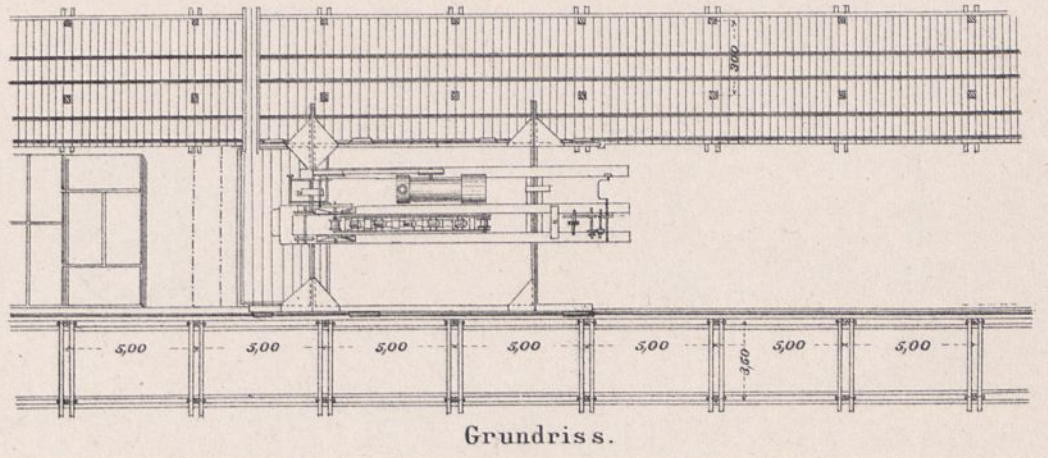
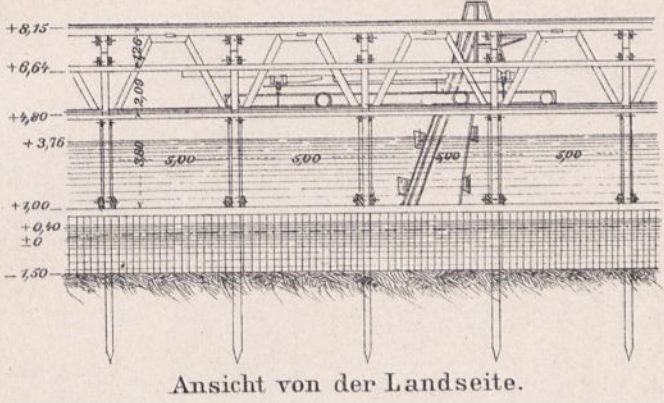
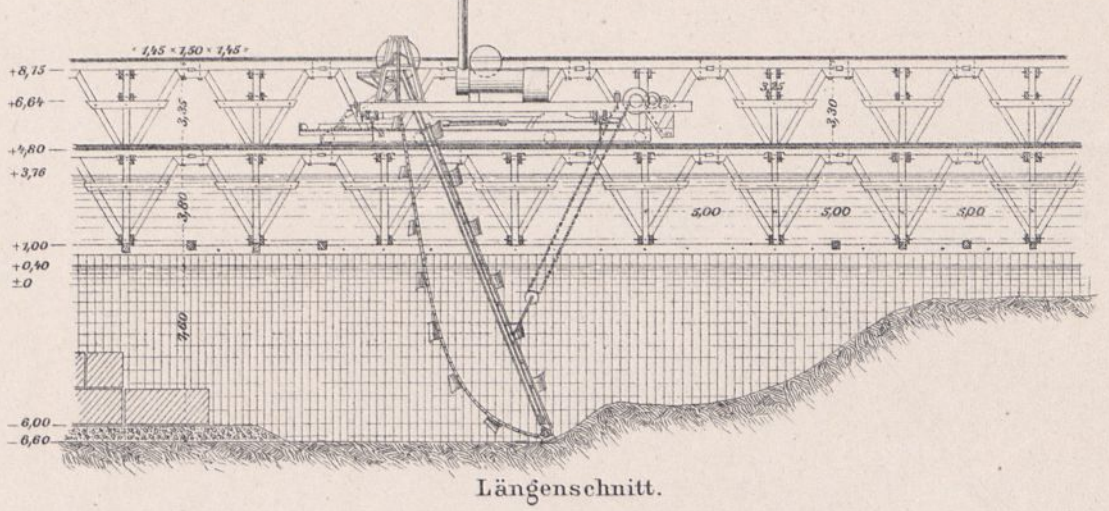
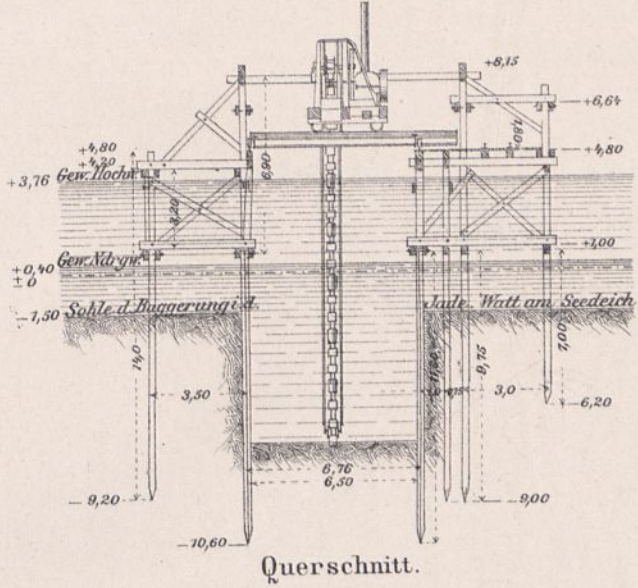

Rüstungen zur Bauausführung. Versetzen der Betonblöcke.

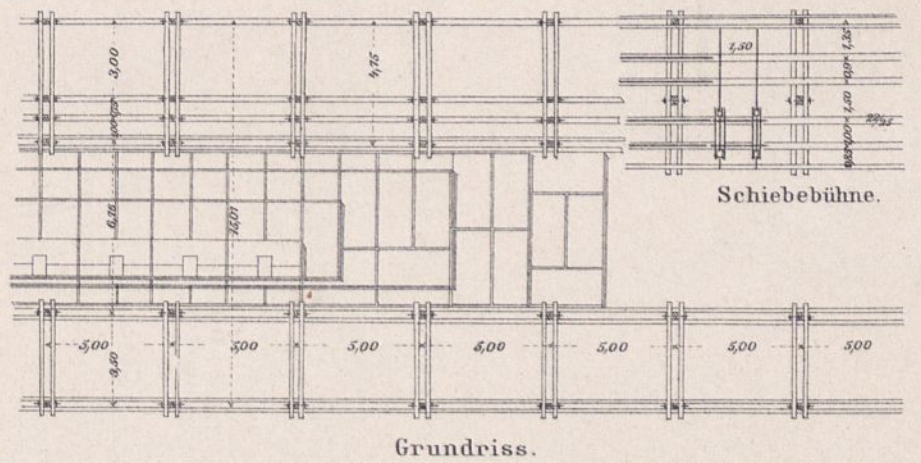
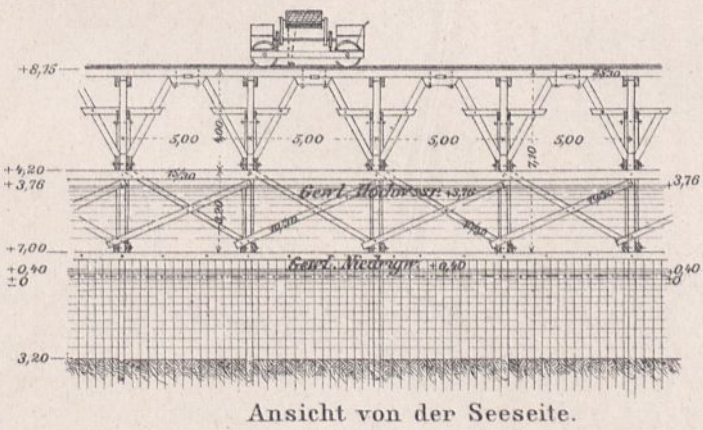
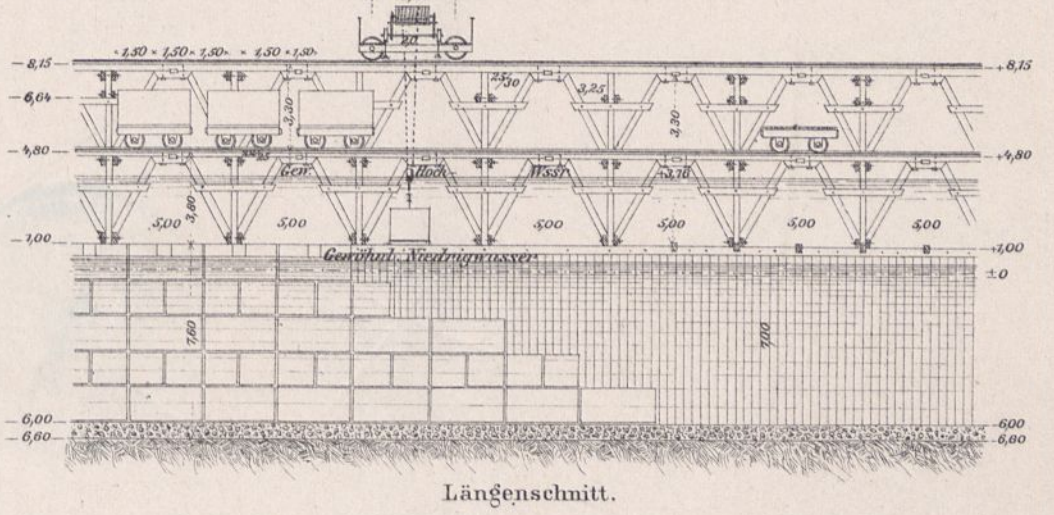
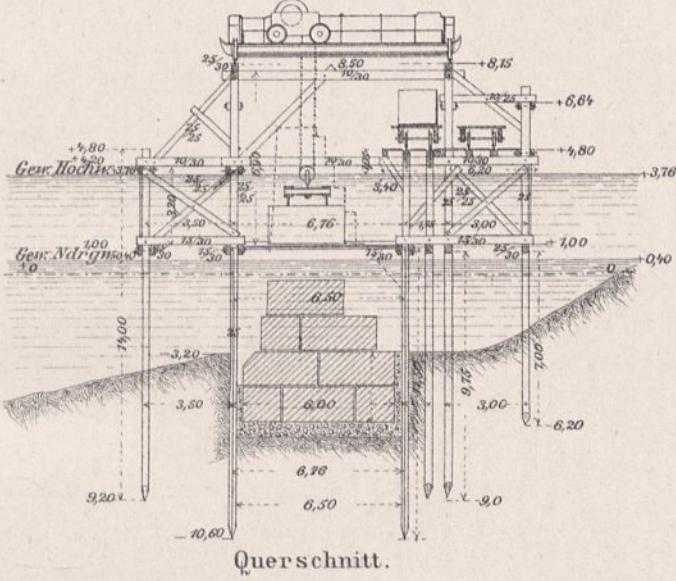

Schiebebühne.

Block-Depot.

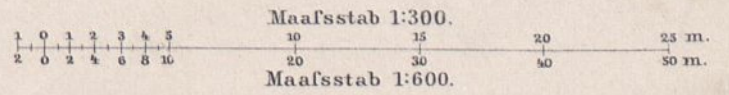
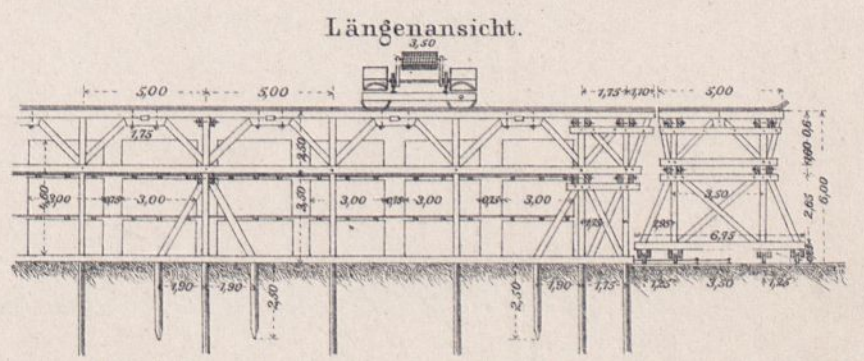
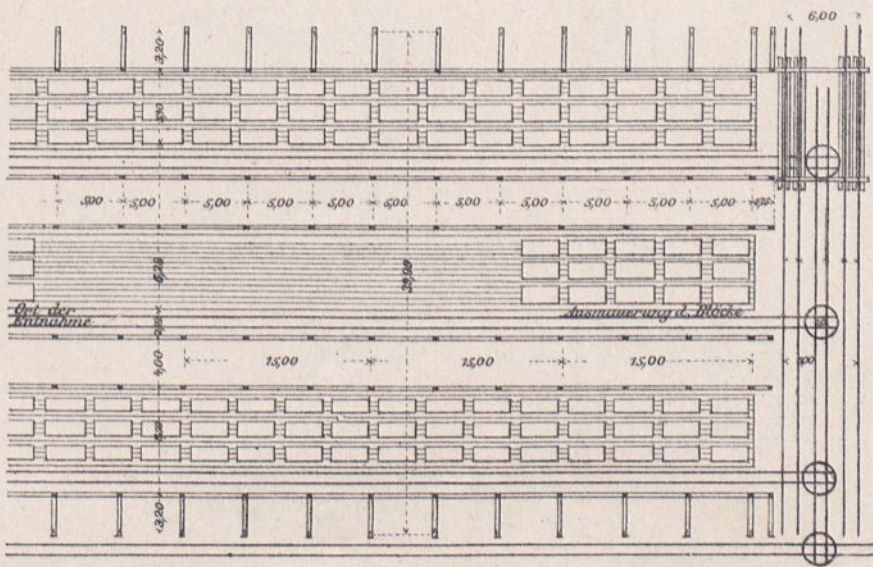
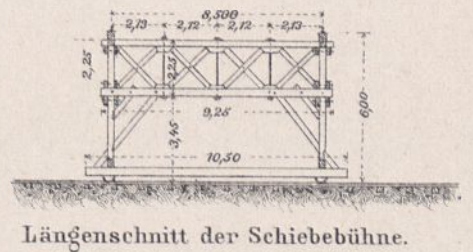
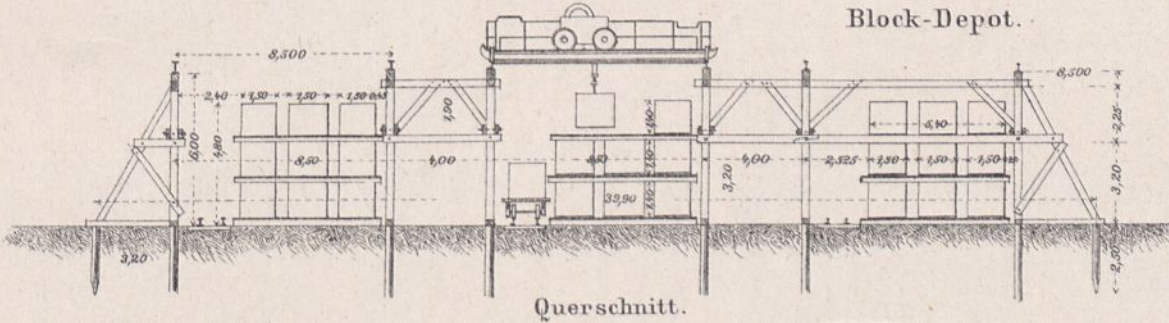

Vorrichtungen zum Heben und Transport der Blöcke.

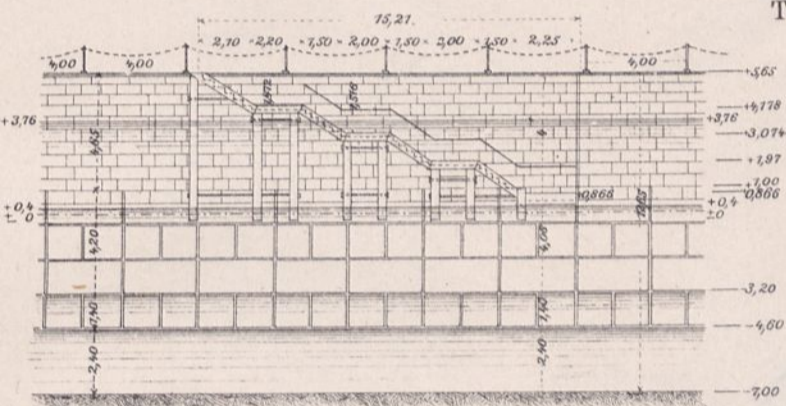
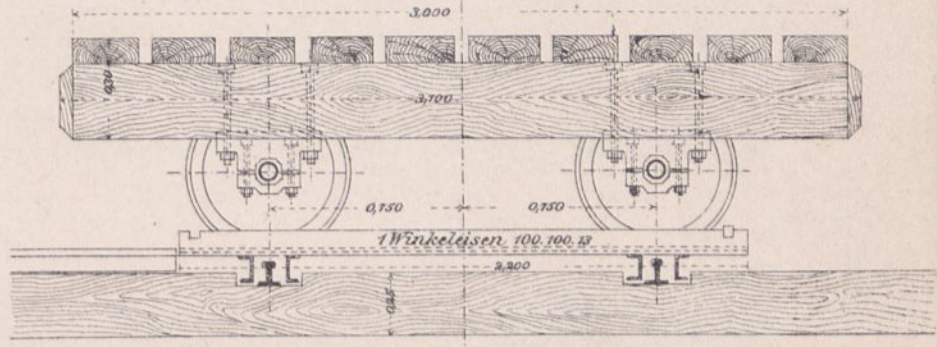
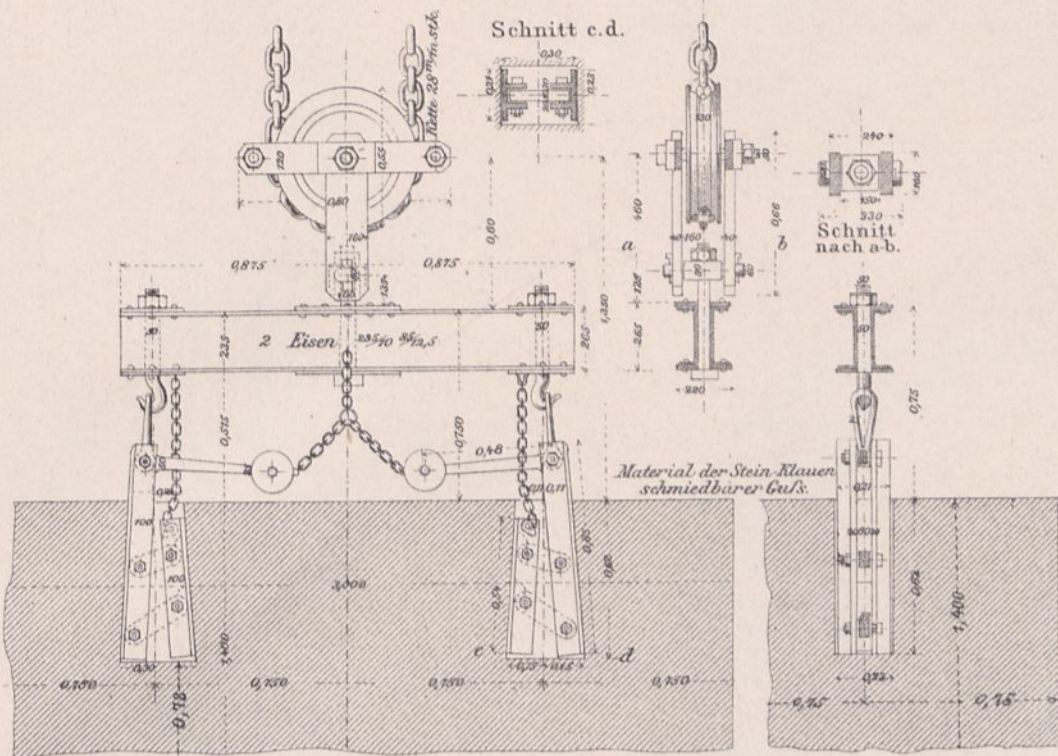

Treppen und Granitverblendung.

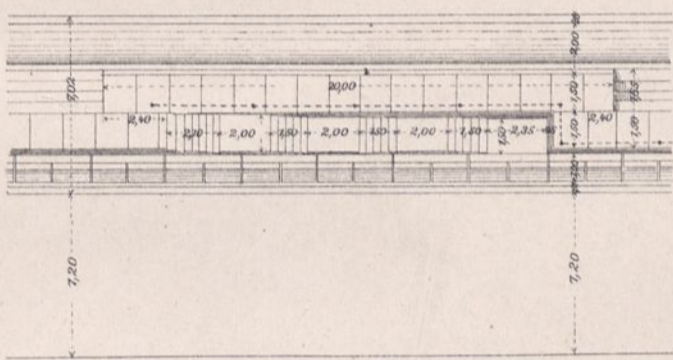
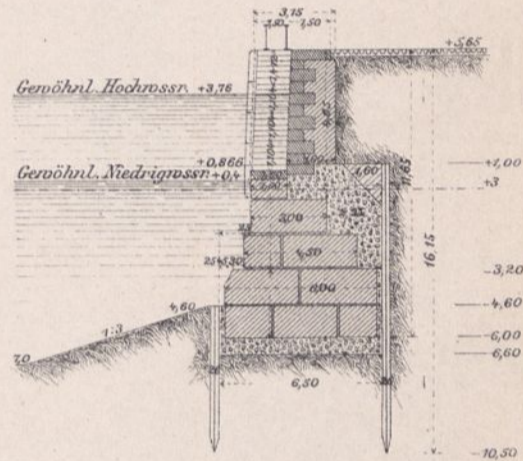
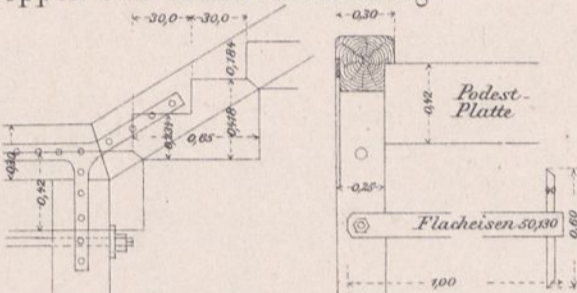

0,366m hoch

0,427 hoch

0,488 hoch

Verblendung der Nordmole.

0,366 hoch

0,427 hoch

0,488 hoch

Verblendung der Süd mole.

Maafsstab 1:30.

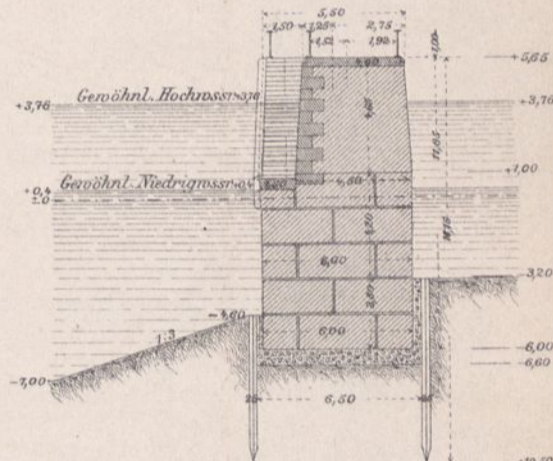

Maafsstab 1:300.

Maafsstab 1:600.

Anschluss der Süd mole am Schleusen Haupt. 1:600.

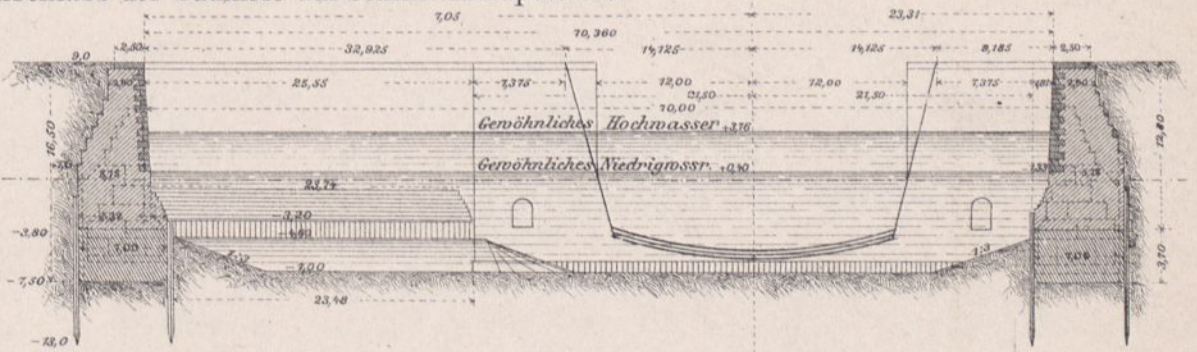
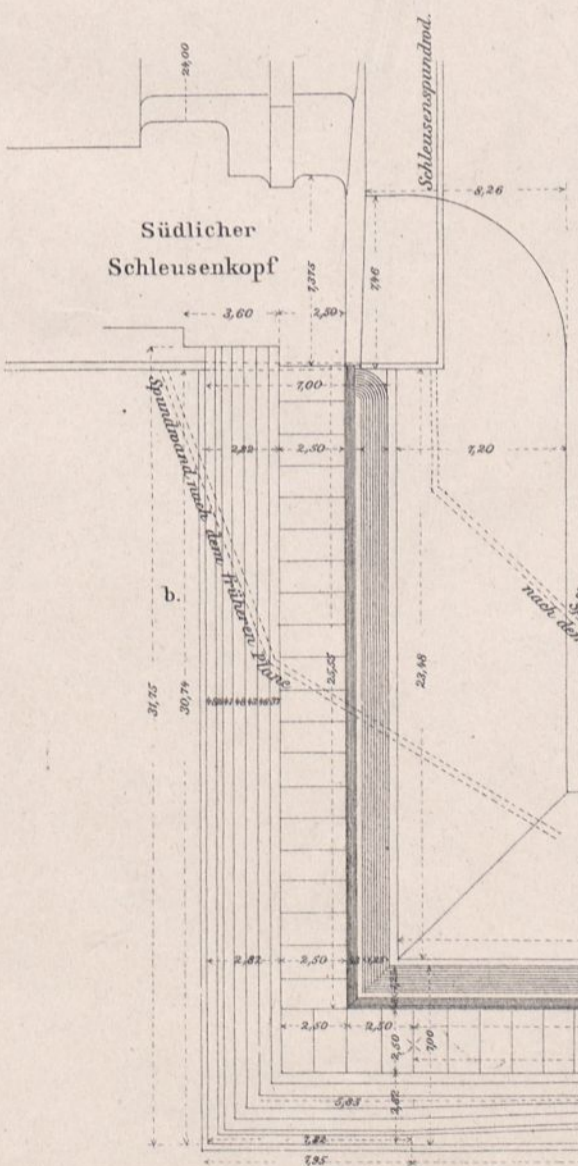

Ansicht. 1 : 1080.

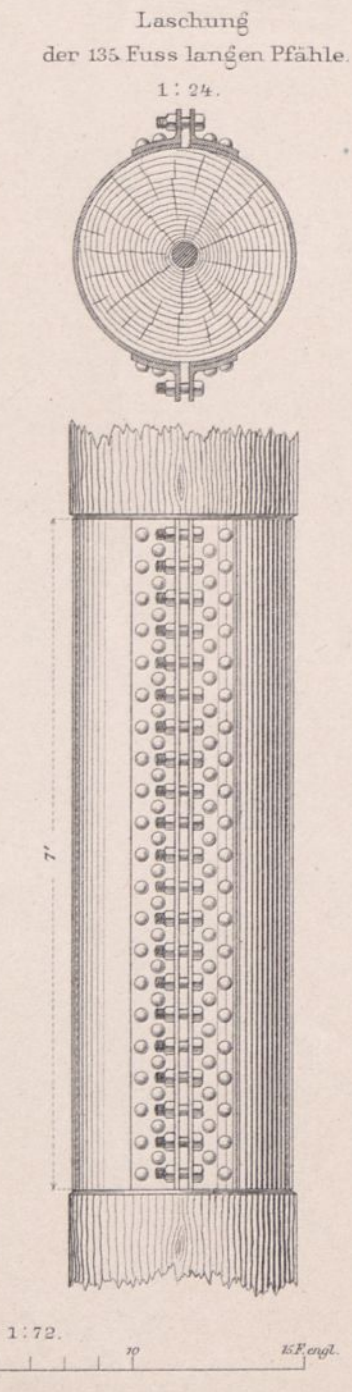
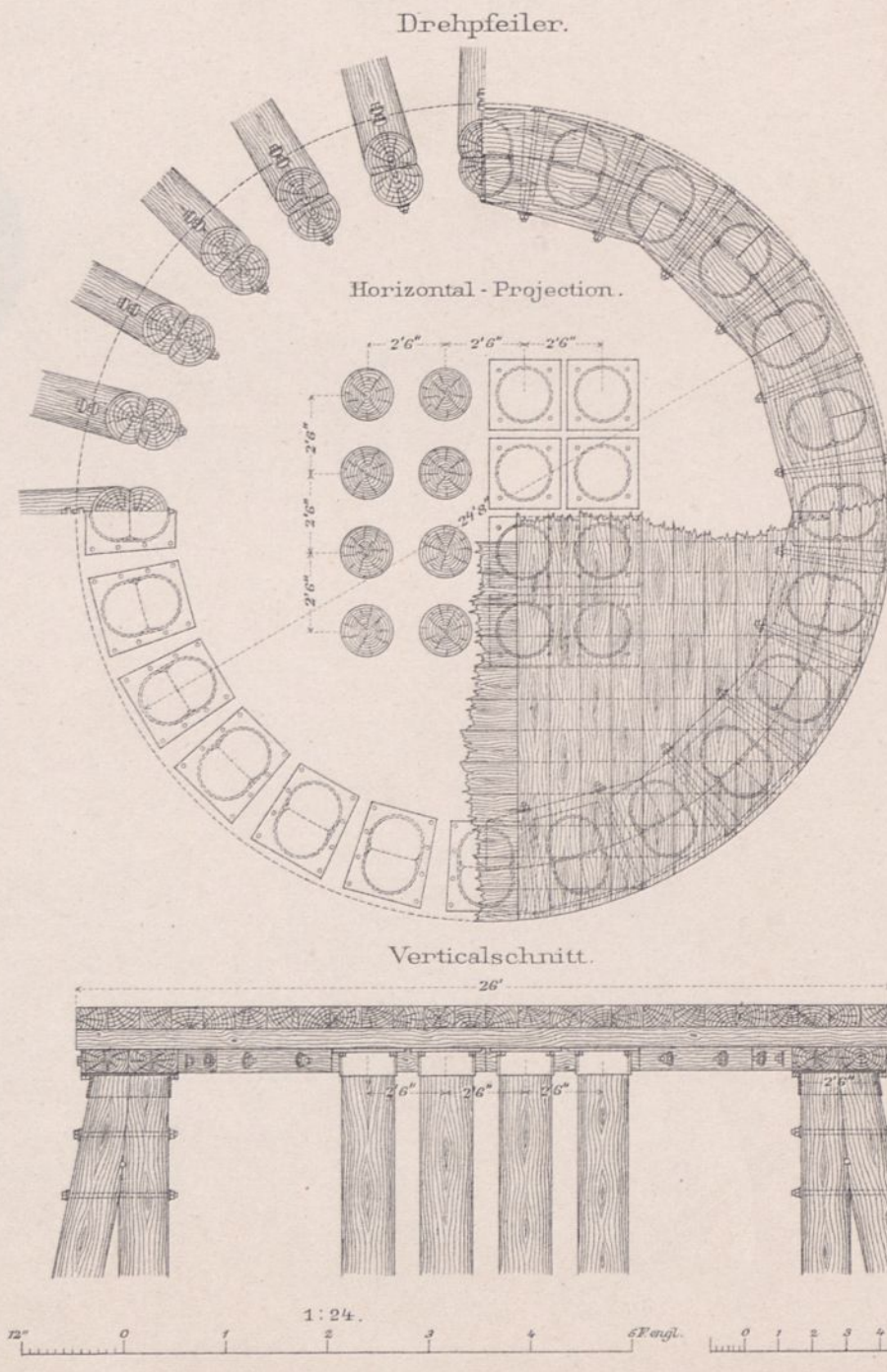
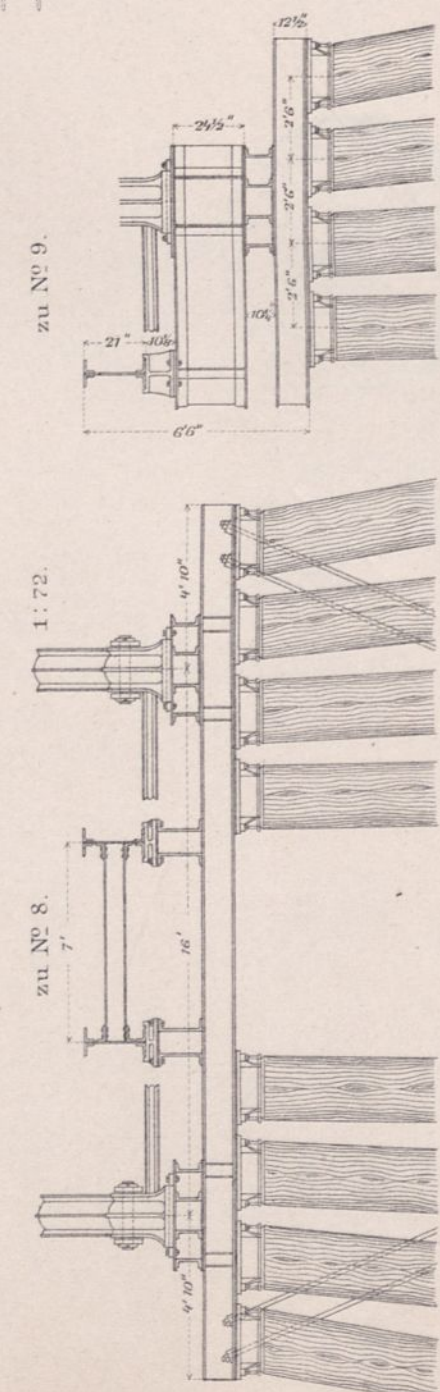
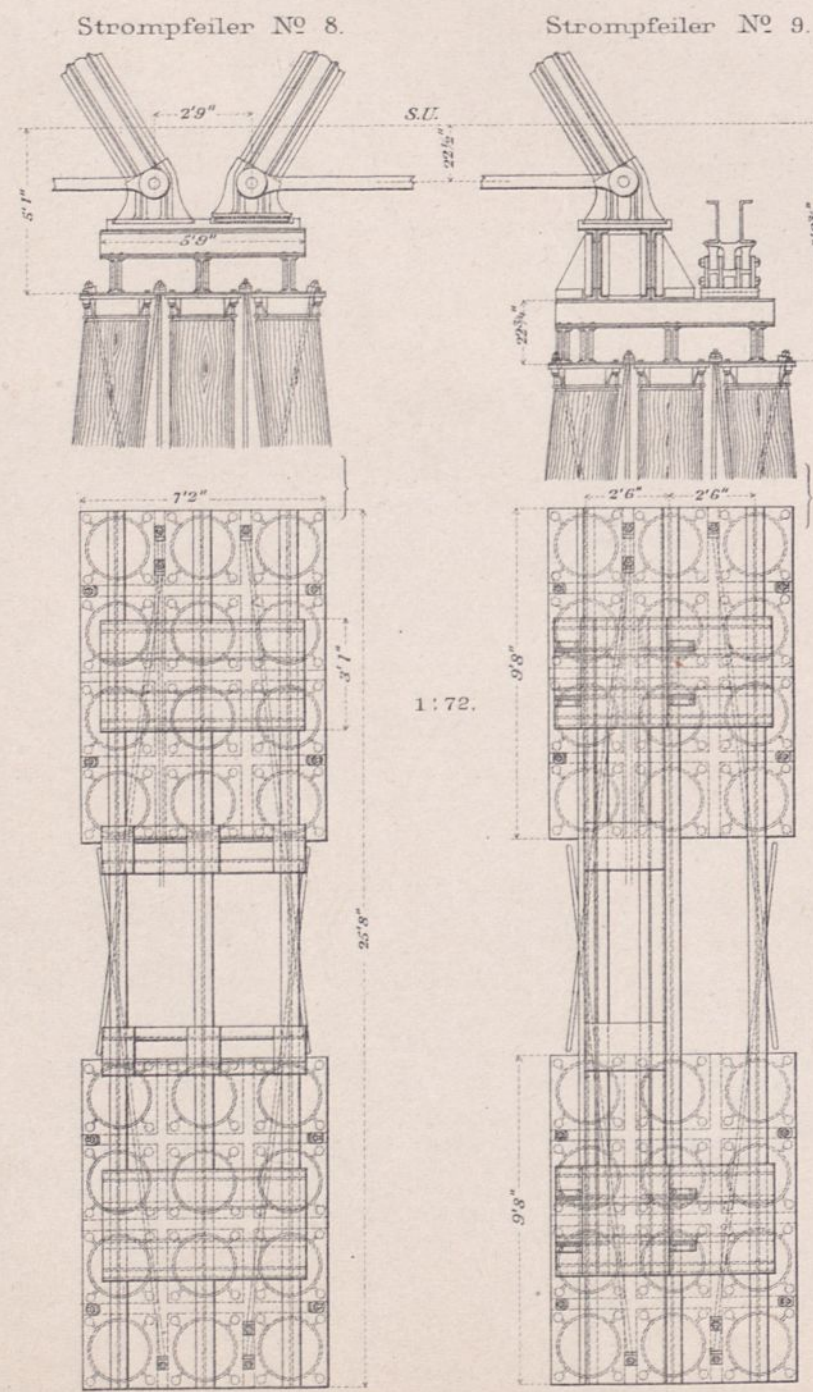
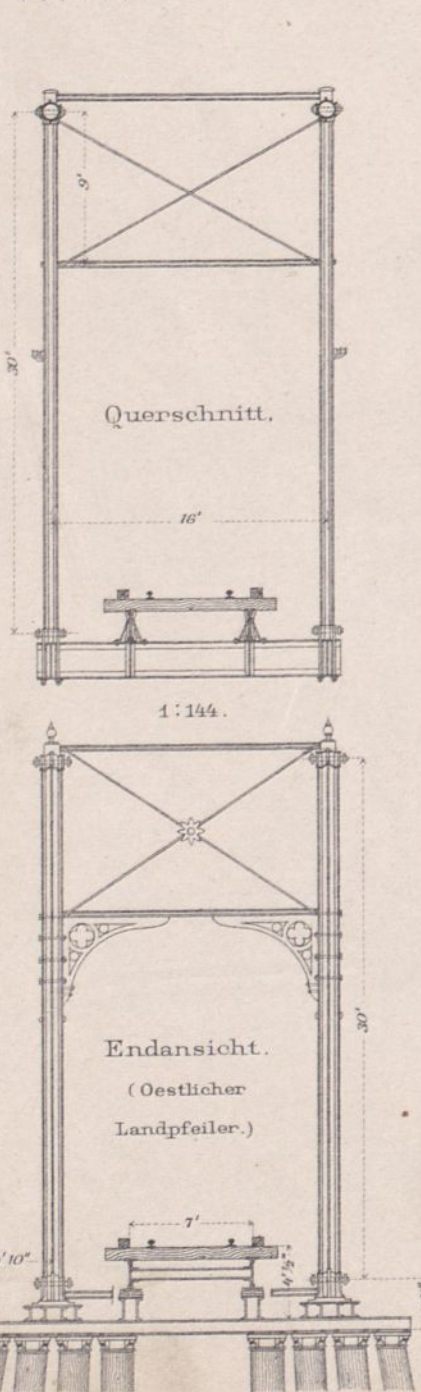
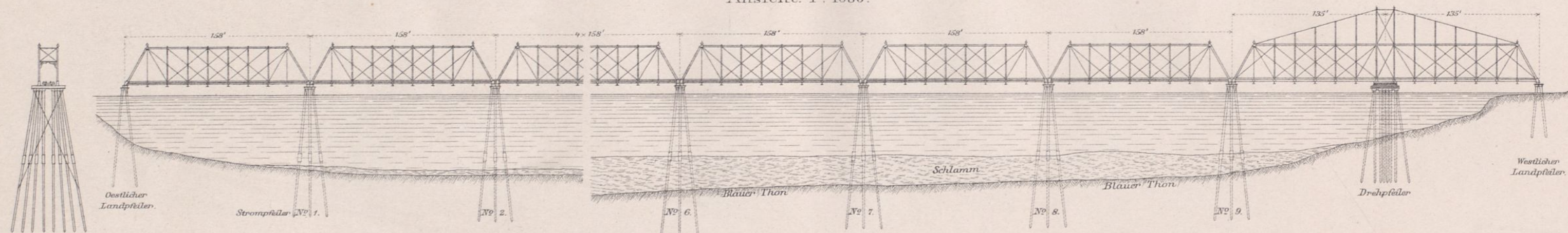

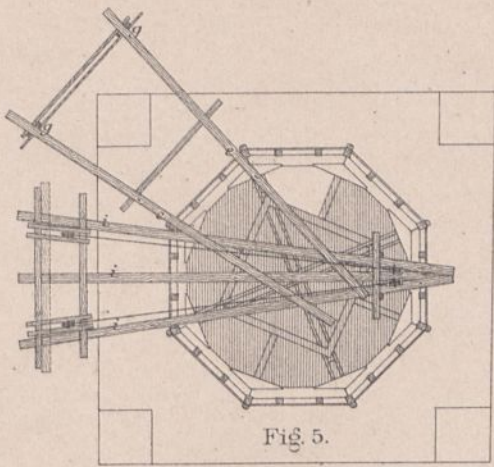

1. Boden.



4. Boden.

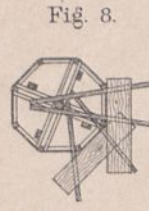

5. Boden.

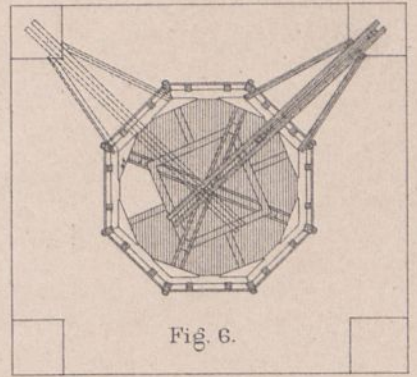

2. Boden.

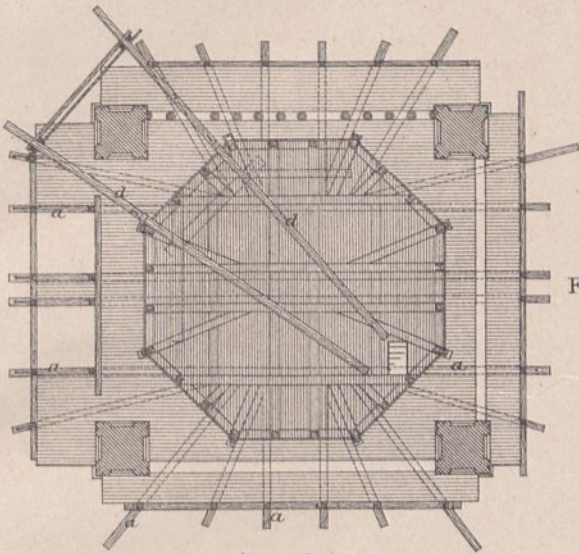

Plattform.

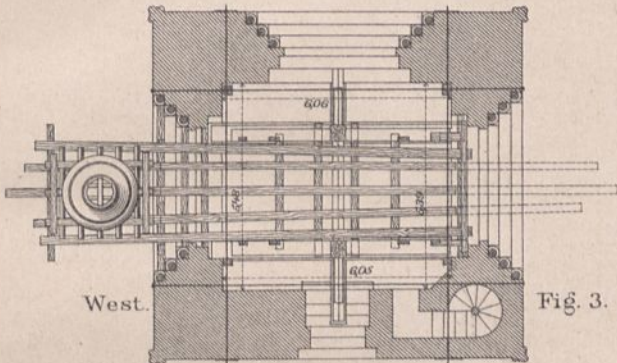

2. Geschoss.

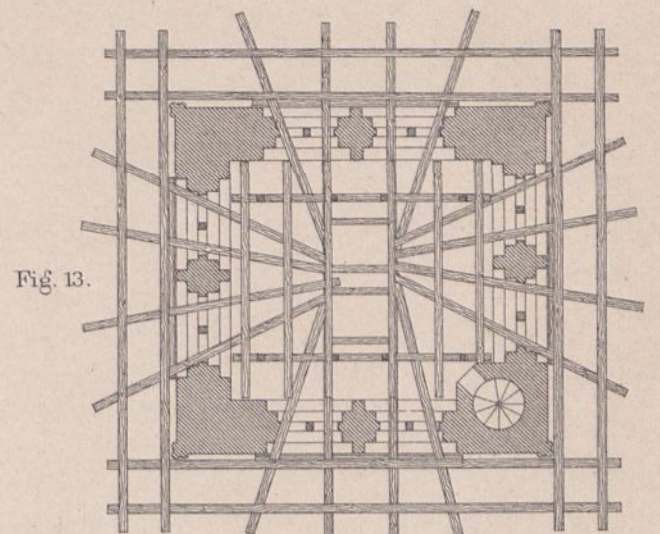

Grundriss bei C.

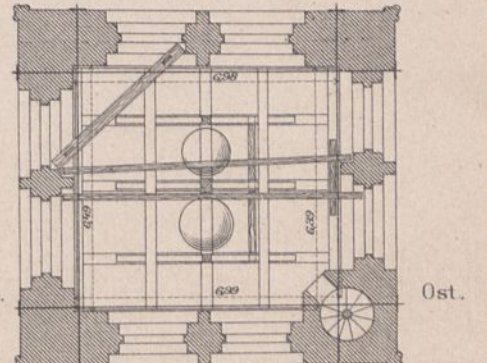

3. Geschoss.

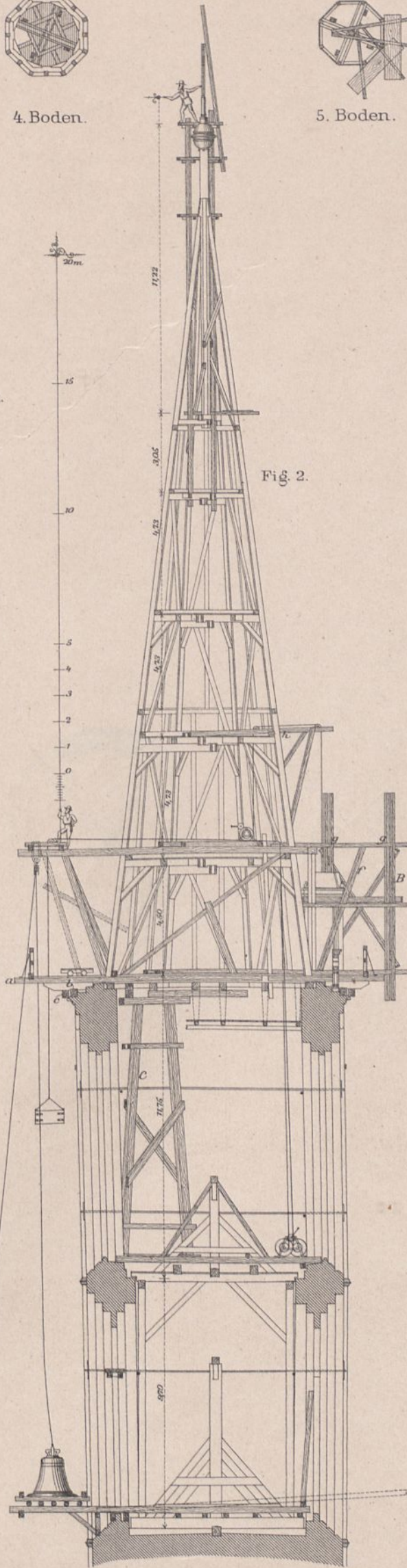
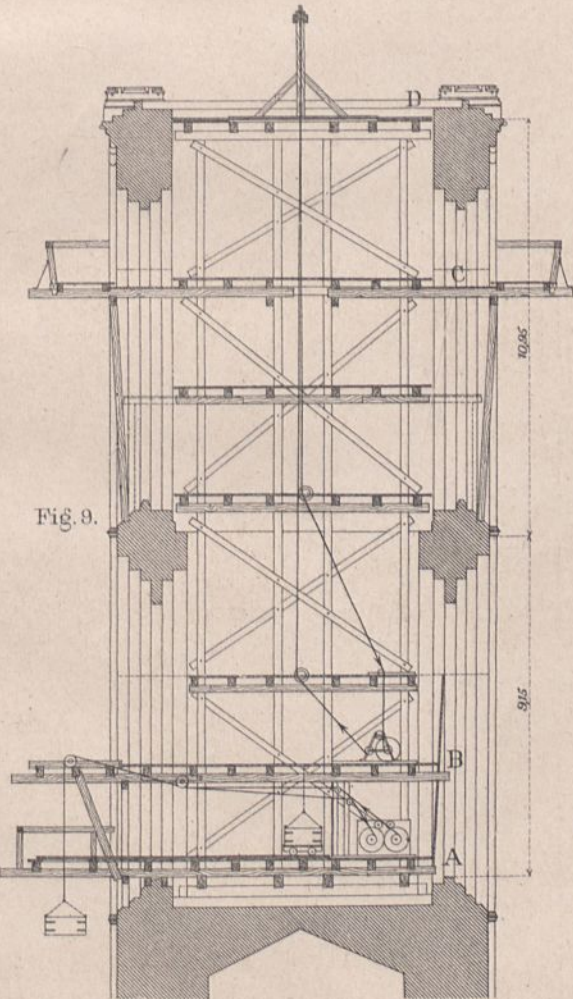
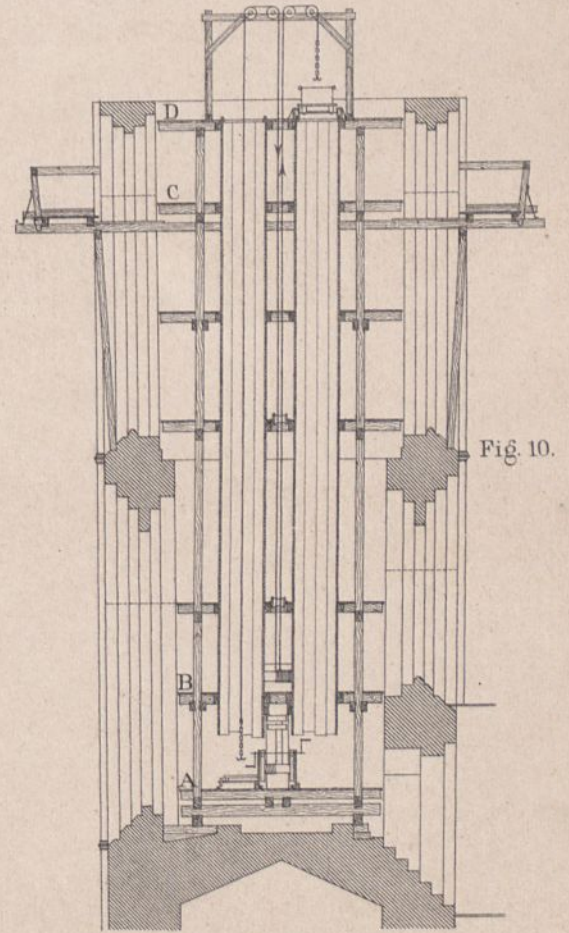

Fig. 2.

Schnitt W0.



Schnitt W0.



Schnitt NS.

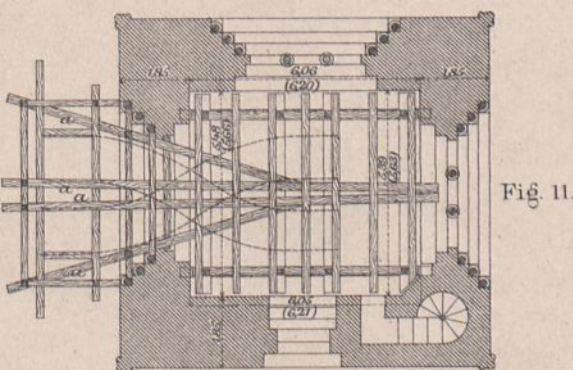

Grundriss bei A.

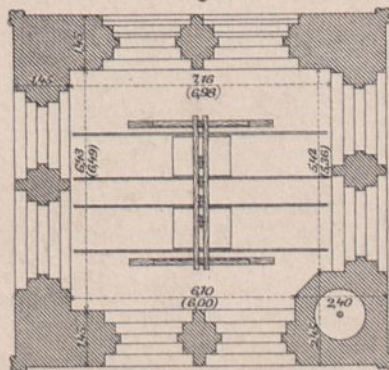

Grundriss bei D.

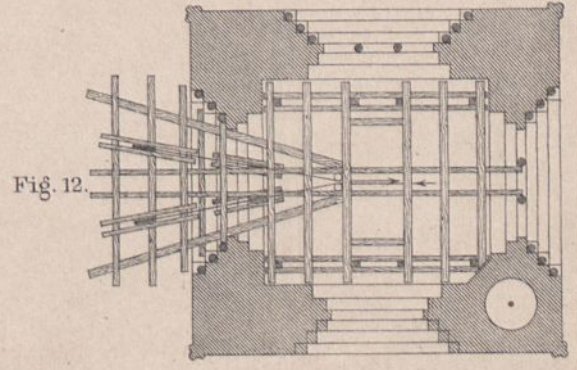

Grundriss bei B.

