

R 96
m

Archiwum



PUBLICATION INDUSTRIELLE

DES

MACHINES, OUTILS ET APPAREILS

LES PLUS PERFECTIONNÉS ET LES PLUS RÉCENTS

EMPLOYÉS

DANS LES DIFFÉRENTES BRANCHES DE L'INDUSTRIE FRANÇAISE ET ÉTRANGÈRE

PAR

ARMENGAUD AINÉ

INGÉNIEUR, ANCIEN PROFESSEUR AU CONSERVATOIRE IMPÉRIAL DES ARTS ET MÉTIERS

CHEVALIER DE LA LÉGION D'HONNEUR

MEMBRE HONORAIRE DE LA SOCIÉTÉ PHILOMATHIQUE DE BORDEAUX ET DE LA SOCIÉTÉ INDUSTRIELLE DE MULHOUSE, MEMBRE DE LA SOCIÉTÉ D'ENCOURAGEMENT, DE LA SOCIÉTÉ DES INGÉNIEURS CIVILS, ETC.

TOME SEIZIÈME

PLANCHES

Reproduction interdite.

1912.499.

Toute communication concernant la rédaction doit être adressée
directement à l'auteur-éditeur :

M. ARMENGAUD AINÉ

INGÉNIEUR

45, RUE SAINT-SÉBASTIEN, A PARIS

Tout ce qui concerne le service des abonnements et la vente des
volumes doit être adressé à

M. A. MOREL

LIBRAIRE

43, RUE BONAPARTE, A PARIS

1866

MACHINES, OPTICS, ET APPAREILS

PIRELLA GÖTTSCHE LOWE



TABLE DES PLANCHES

DU TOME SEIZIÈME DE LA PUBLICATION INDUSTRIELLE

| PLANCHES. | 1 ^{re} LIVRAISON. | PAGES. | PLANCHES. | 6 ^e LIVRAISON. | PAGES. |
|---|--|--------|--|--|--------|
| 1 | Pompe à comprimer l'air, actionnée directement par un moteur à vapeur, par MM. E. GOUIN ET C ^{ie} | 1 | 21 | Machine à laminier les bandages de roues, pour véhicules de chemin de fer, par MM. LE BRUN et LÉVÊQUE..... | 240 |
| 2 | Pont roulant avec treuil mobile à chaîne Galle, de 40 tonnes, exécuté pour les ateliers de la marine impériale, par M. NEUSTADT..... | 9 | 22 | Machine à raboter transversalement et à chantourner les métaux, dite étau-limeur, par MM. F. ARBEY ET C ^{ie} | 268 |
| 3 | Métier à la Jacquart, à papier continu substitué aux chapelets de carton, par M. François DURAND..... | 46 | 23 | Grue roulante à vapeur de 40 tonnes, par M. QUILLACQ..... | 276 |
| 4 | Machines radiales à percer les métaux, par M. HARTMANN..... | 30 | 24 | Grues roulantes à chariot et à vapeur pour gares et quais, par M. L. A. QUILLACQ..... | 279 |
| | 2^e LIVRAISON. | | | 7^e LIVRAISON. | |
| 5 | Appareils d'injection, dits Sterhydraulique et presse chauffée à la vapeur, par MM. DESGOFFE ET OLLIVIER..... | 37 | 25 } Machines d'épuisement appliquées aux formes de radoub du port | | |
| 6 | Formes de radoub, établies au port d'Alger par M. HARDY..... | 50 | 26 } d'Alger, construites par MM. NILUS et FILS..... | 297 | |
| 7 | Machines à concasser les pierres et les minerais..... | 75 | 27 | Marteau-pilon à vapeur, de grande puissance, construit chez MM. KAMP et C ^{ie} , sous la direction de MM. DAHLAUS et TRAPPEN..... | 307 |
| 8 | Métier mécanique à tisser les draps nouveautés, par M. BACOT..... | 93 | 28 | Machine à broyer et à teiller le chanvre, par M. LÉONI et COBLENZ .. | 325 |
| | 3^e LIVRAISON. | | | 8^e LIVRAISON. | |
| 9 | Machine à vapeur marine à cylindres inclinés, par MM. FAIVRE FRÈRES. | 407 | 29 | Machine à broyer et à teiller le chanvre, par MM. LÉONI et COBLENZ .. | 325 |
| 10 | Scieries circulaires de divers systèmes pour débiter les bois et les façonner, par MM. F. ARBEY ET C ^{ie} | 425 | 30 | Turbine hélicoïdale à élever de grands volumes d'eau, système CORDIER, construite par MM. LE BRUN ET LÉVÊQUE..... | 349 |
| 11 } Machine locomotive de grande puissance à quatre cylindres, à six | | | 31 | Métier à tisser à alimentation continue, par MM. GRAWFORD et TEMPLETON. | 363 |
| 12 } essieux accouplés, par M. PETIET..... | 433 | | 32 | Machine à tailler les roues d'engrenage, par WHITWORTH..... | 374 |
| | 4^e LIVRAISON. | | | 9^e LIVRAISON. | |
| 13 } Locomotives de grande puissance à quatre cylindres, à cinq et | | | 33 | Grue de fonderie de 22 tonnes, par M. NEUSTADT..... | 379 |
| 14 } à six essieux, par M. PETIET..... | 433 | | 34 | Machine à vapeur locomobile, par M. ISIDORE NILUS..... | 389 |
| 15 | Grue roulante à treuil, système chaîne Galle, par M. NEUSTADT..... | 480 | 35 | Machines radiales à percer les métaux, par M. FAIRBAIRN et E. HULSE. | 401 |
| 16 | Machine à lire et piquer le papier continu pour métier à la Jacquart, par M. François DURAND..... | 487 | 36 | Disposition d'ensemble de la brasserie de M. F. BOUCHEROT. — Appareils de MM. SÉRAPHIN FRÈRES..... | 407 |
| | 5^e LIVRAISON. | | | 10^e LIVRAISON. | |
| 17 | Machine à piquer le papier continu pour Jacquart, par M. F. DURAND. | 487 | 37 | Brasserie de M. F. BOUCHEROT. — Appareils de MM. SÉRAPHIN FRÈRES. | 407 |
| 18 | Plaque tournante en acier et à tampons mobiles de calage, par M. POULET | 201 | 38 | Bateau pompeur appliqué à l'extraction des vases molles, par MM. GACHE aîné, JOLLET et BABIN..... | 435 |
| 19 | Machine à vapeur à disque, double, et à détente, par M. MOLARD.... | 245 | 39 | Filature de coton. — Cardé déboureur automate, par M. RISLER.... | 444 |
| 20 | Bateau-porte de l'une des formes sèches du port d'Alger, par M. HARDY, construit par MM. NILUS et FILS..... | 231 | 40 | Machine à mortaiser les moyeux de roues, par M. PERIN..... | 451 |



M^{rs}. E. Gouin et Comp^{ts} constructeurs.

Fig. 1.

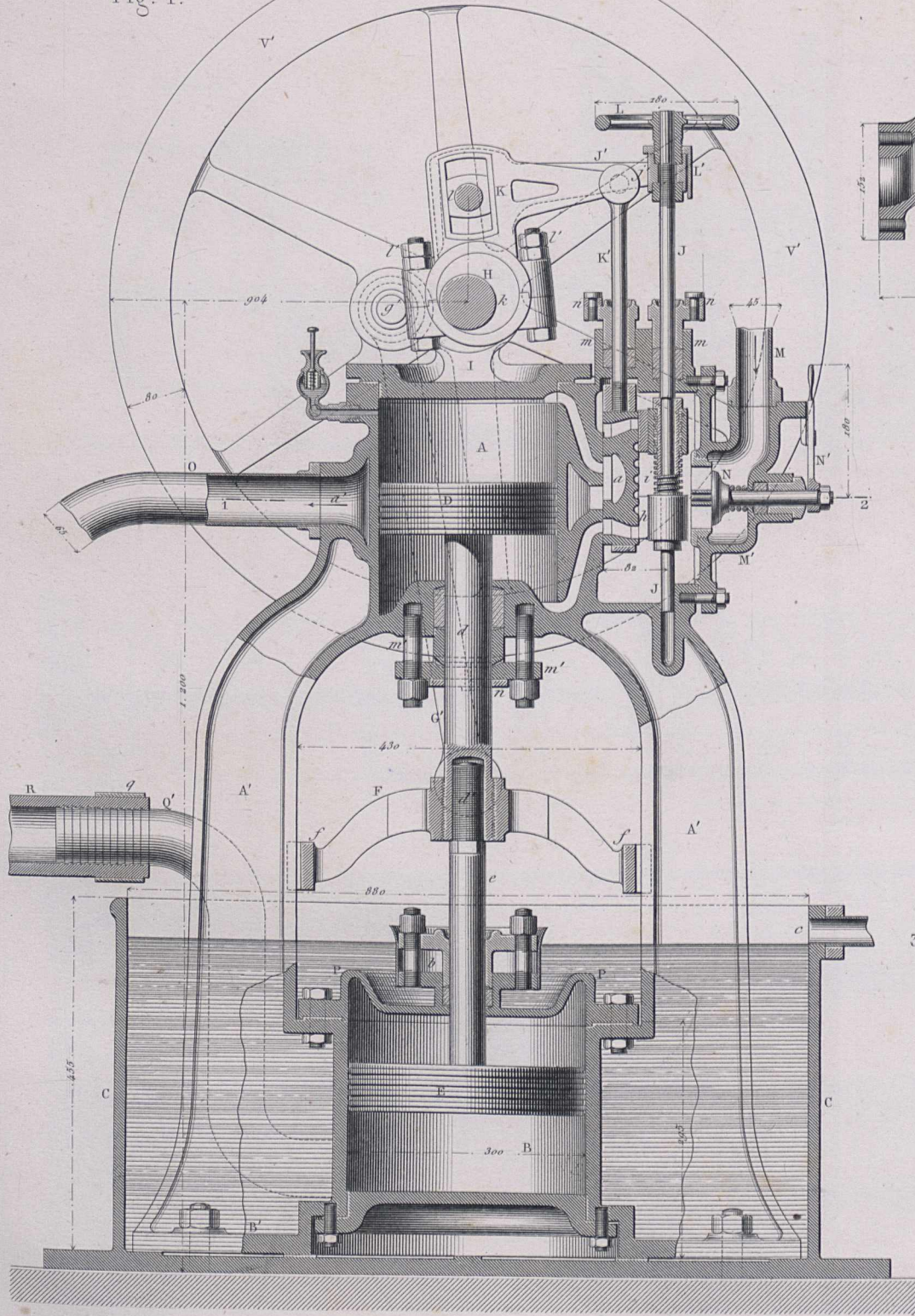

Fig. 3.

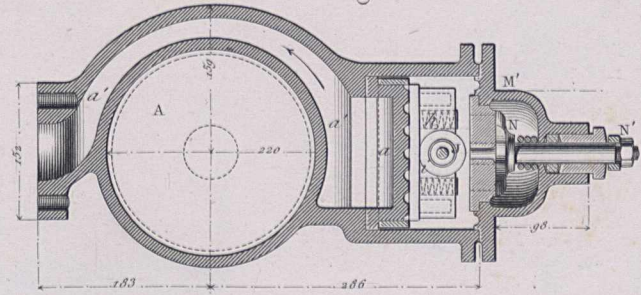

Fig. 4.

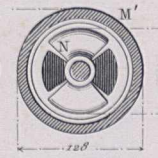

Fig. 5.

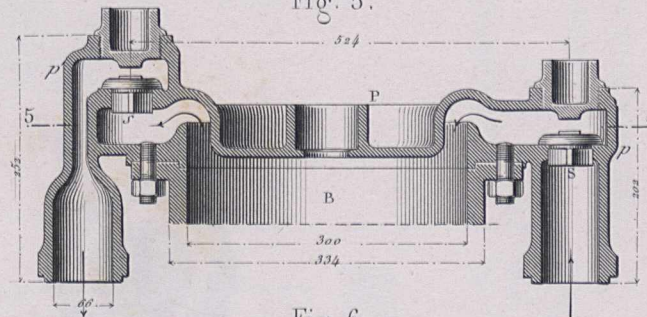

Fig. 6.

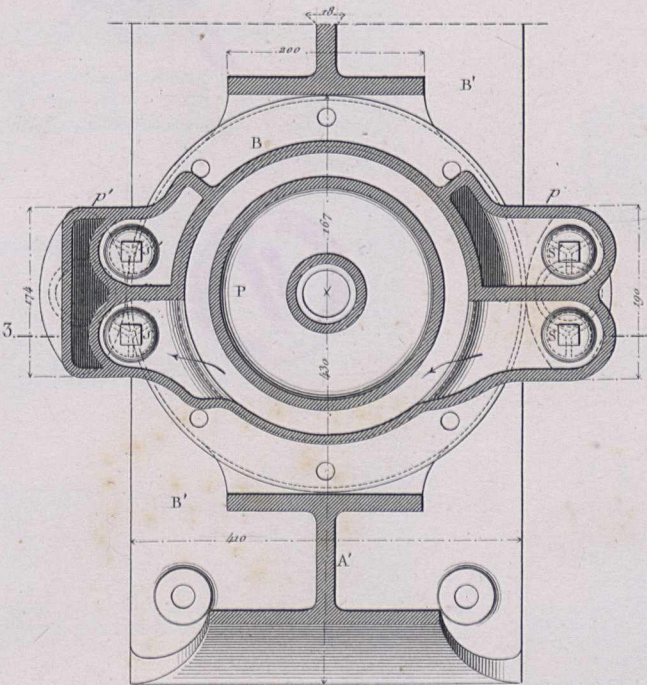
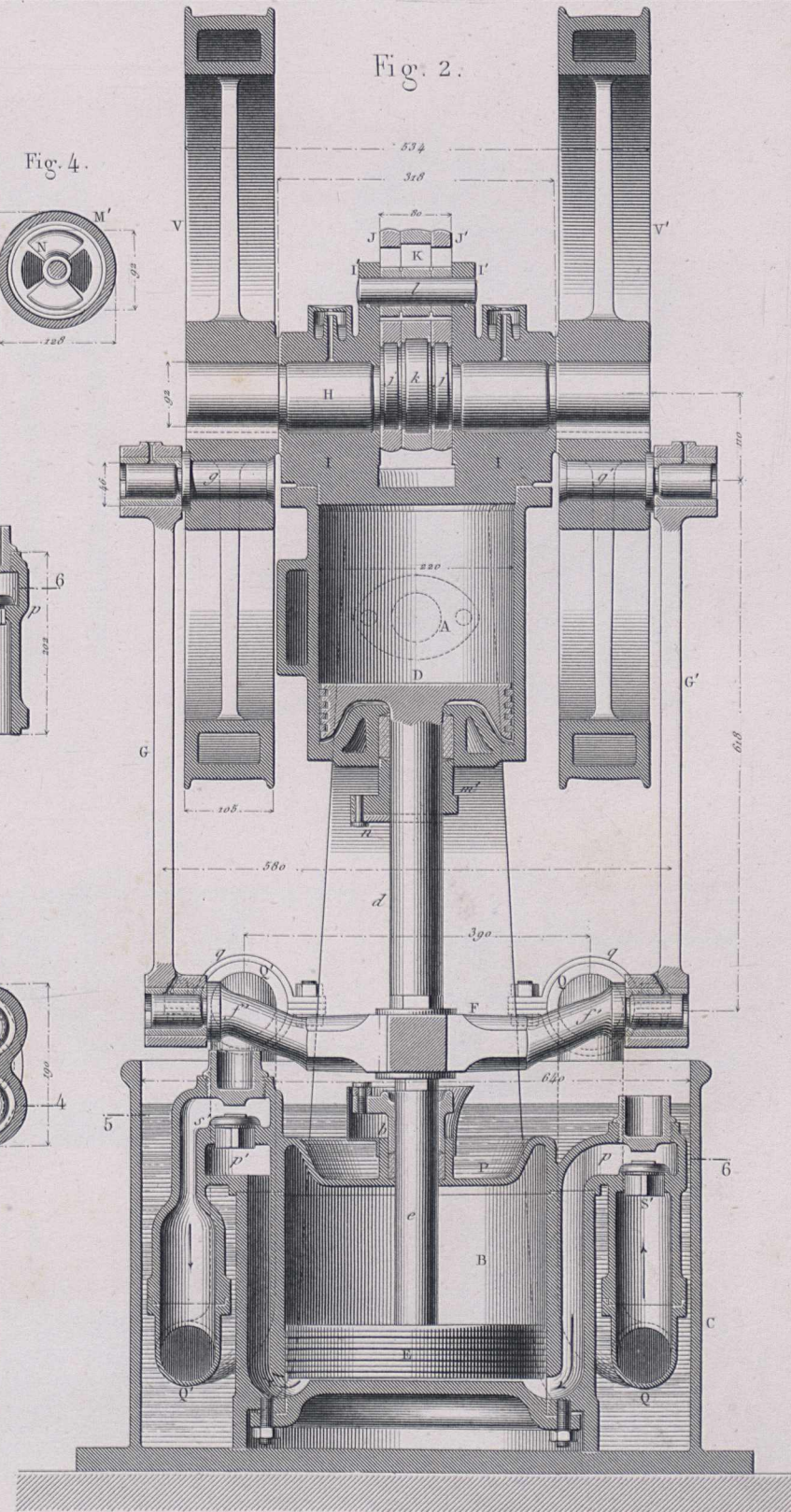

Fig. 2.



Echelle de 1/8



Fig. 3.

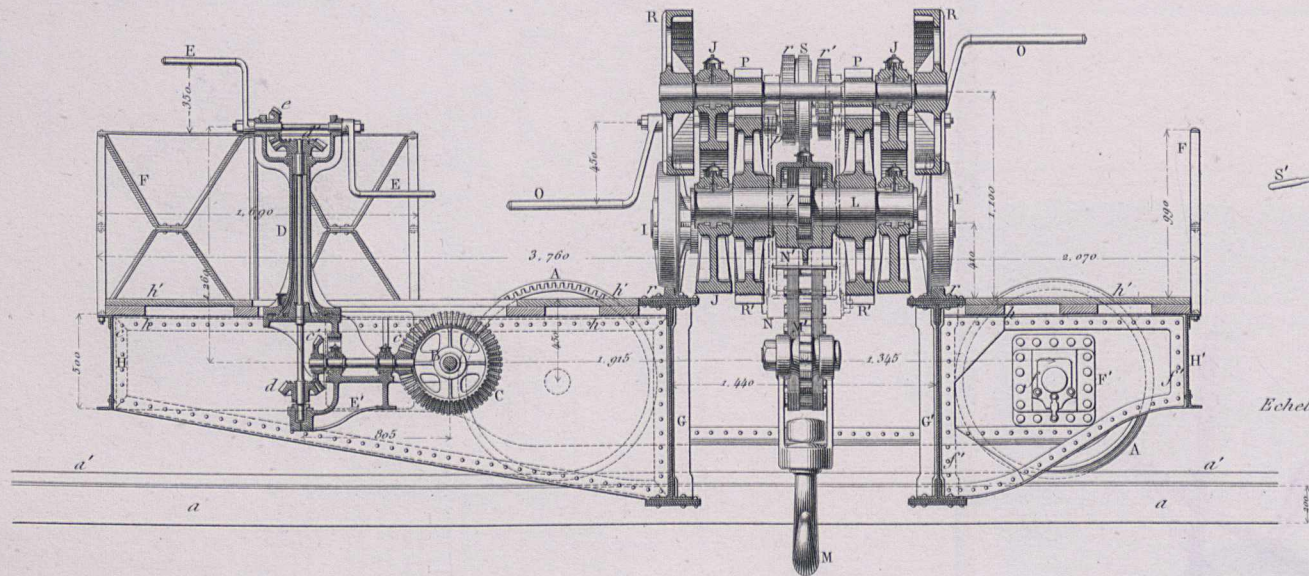

Fig. 4.

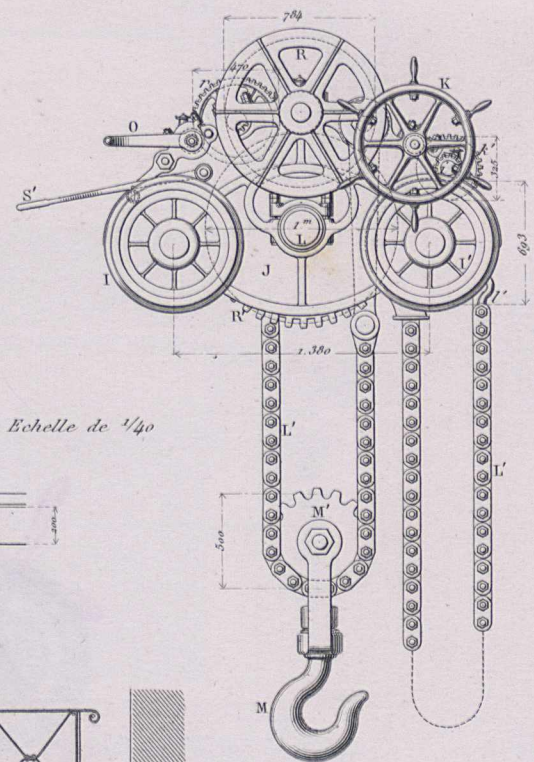

Fig. 5.

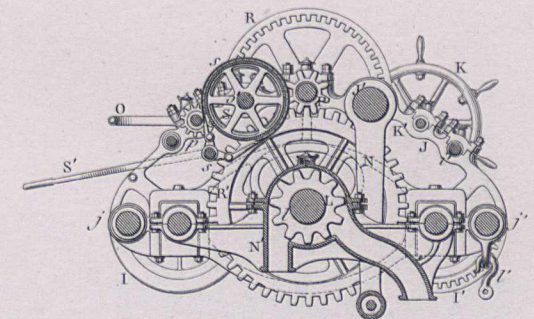

Fig. 6.

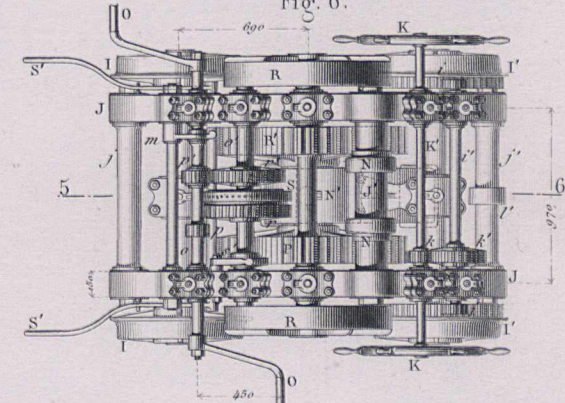

Fig. 2.

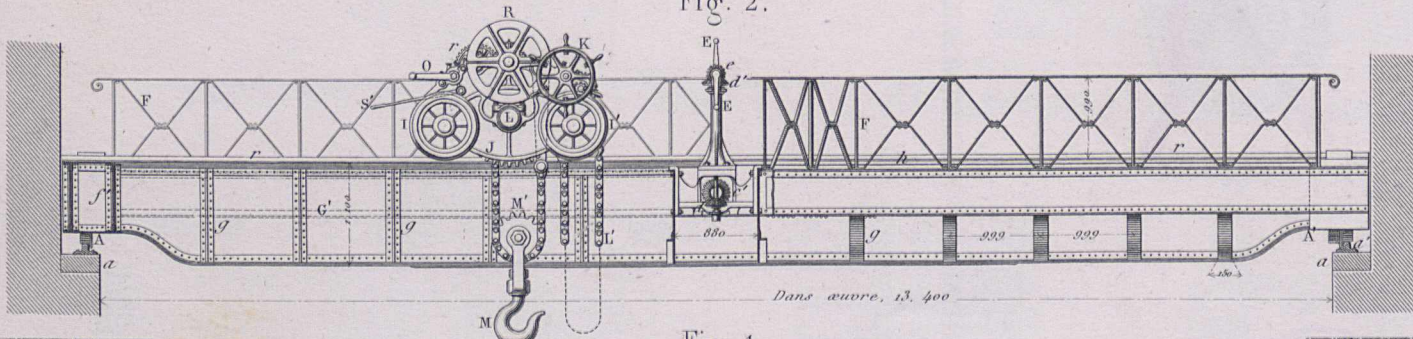

Fig. 1.

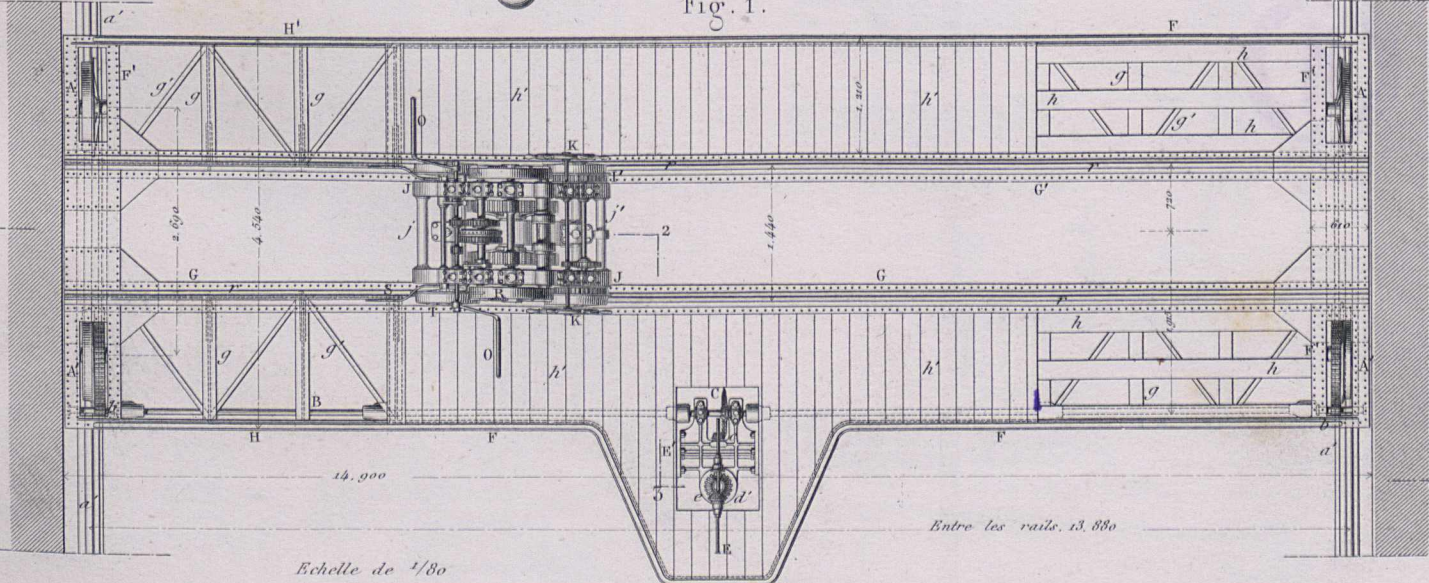

Fig. 7.

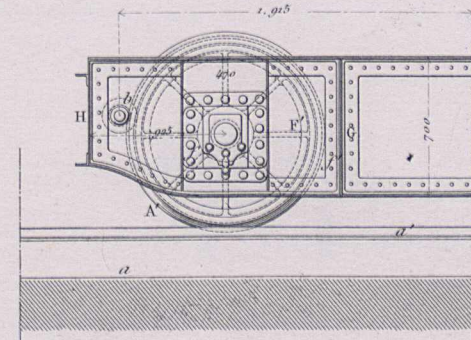

Fig. 8.

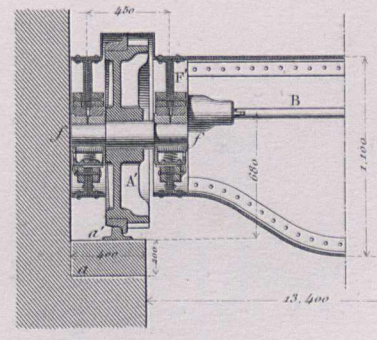

Fig. 9.

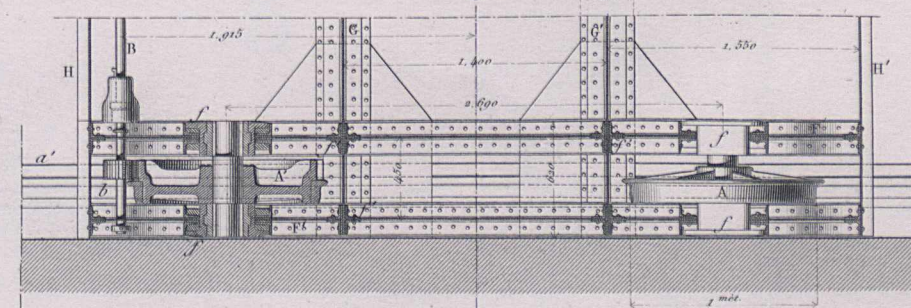
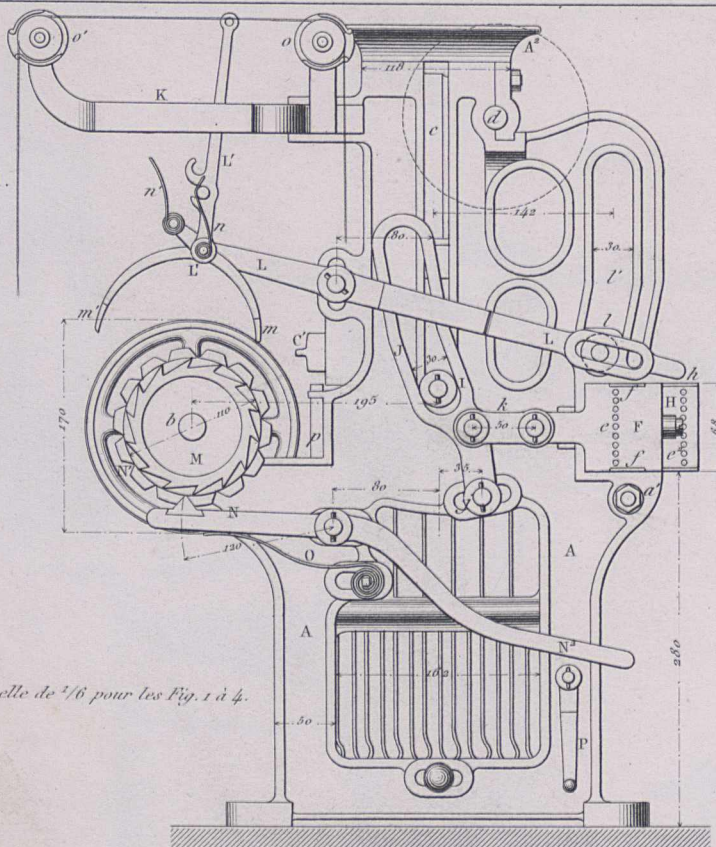



Fig. 1.



Echelle de 1/6 pour les Fig. 1 à 4.

Fig. 2.

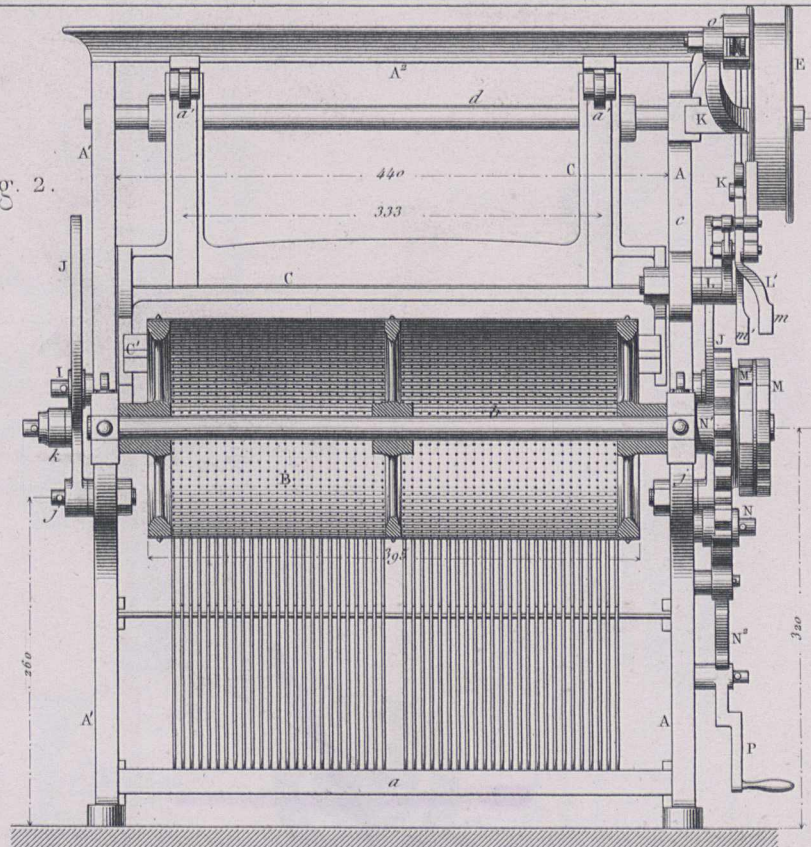
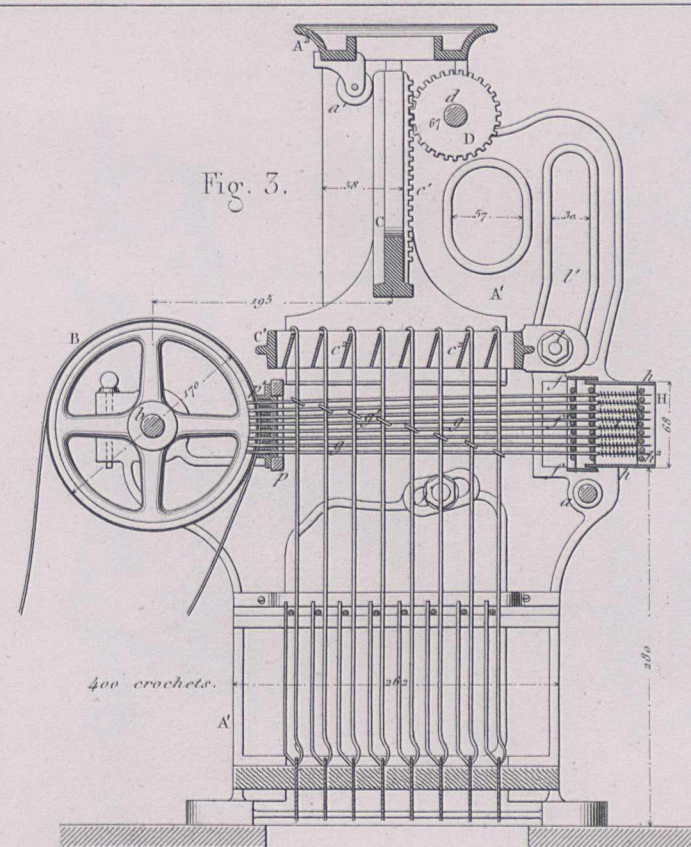

Fig. 3.



400 crochets.

Fig. 4.

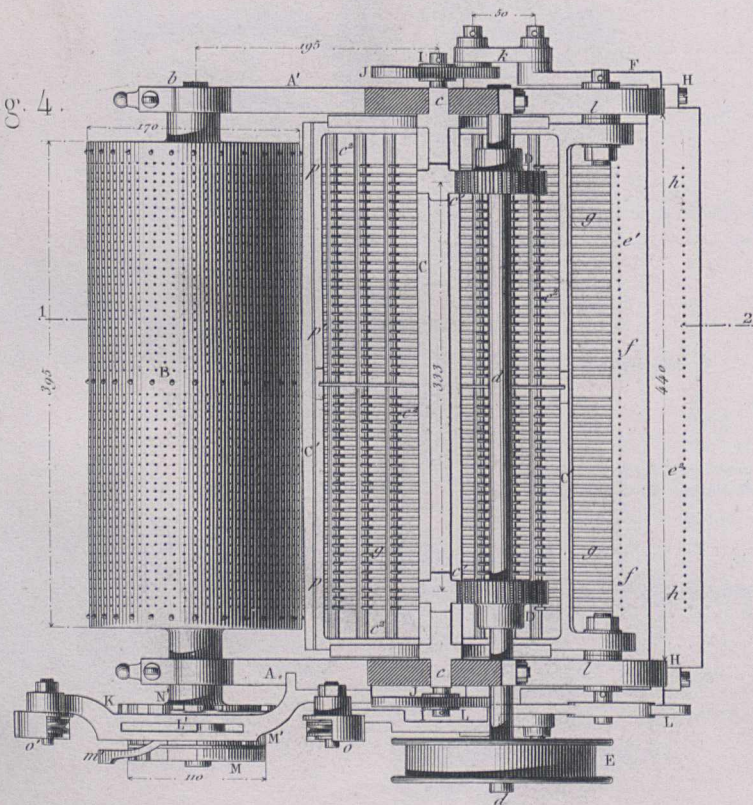

Fig. 5.

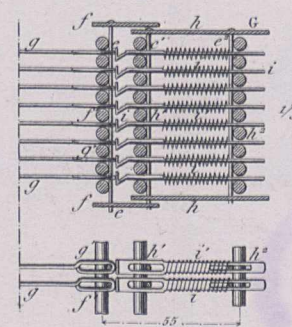
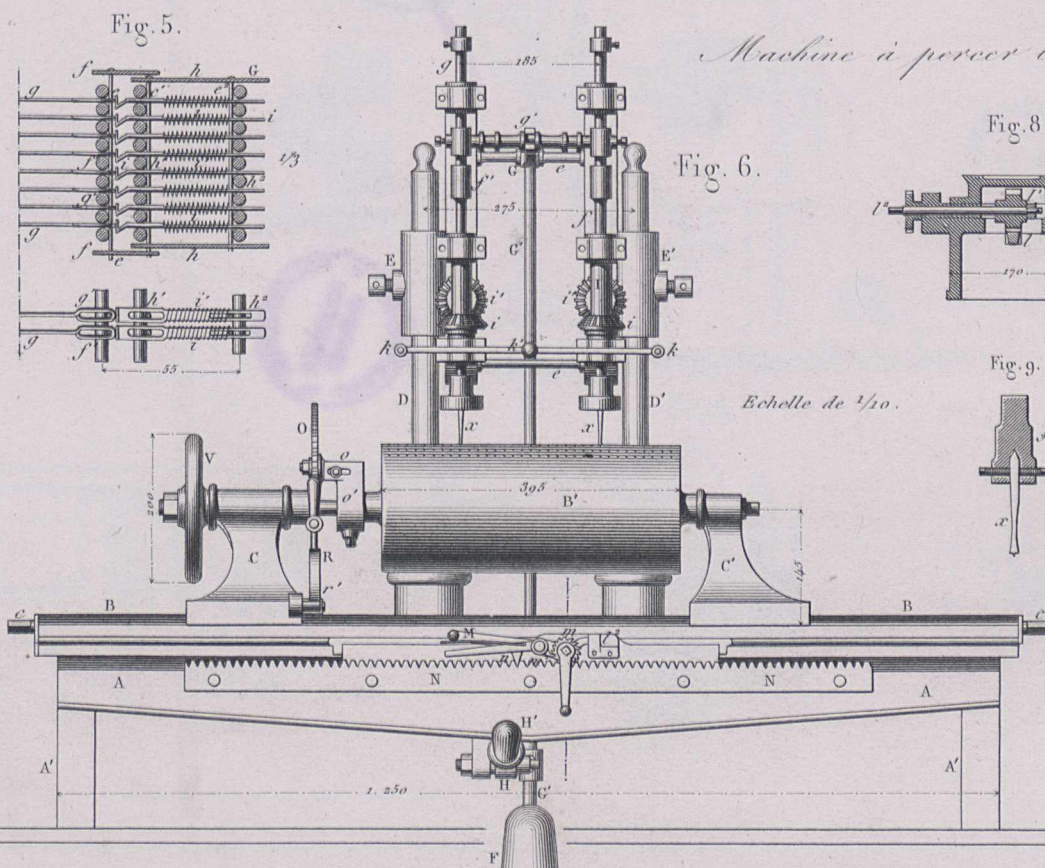

Fig. 6.



Machine à poser les Cylindres.

Echelle de 1/10.

Fig. 8.

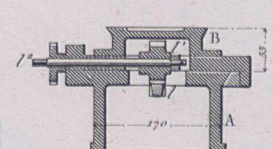

Fig. 9.

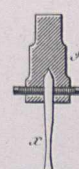
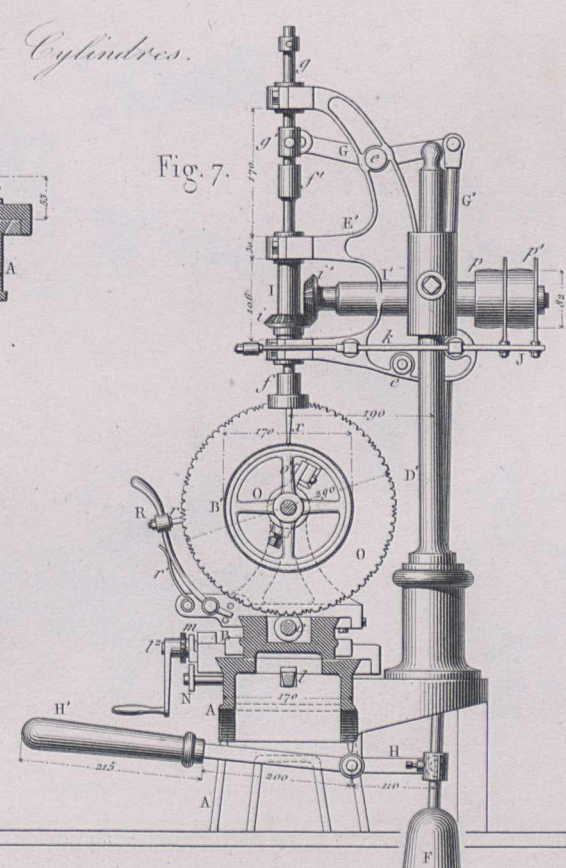

Fig. 7.





Perceuse radiale à plateau.

Perceuse appliquée sur colonne.

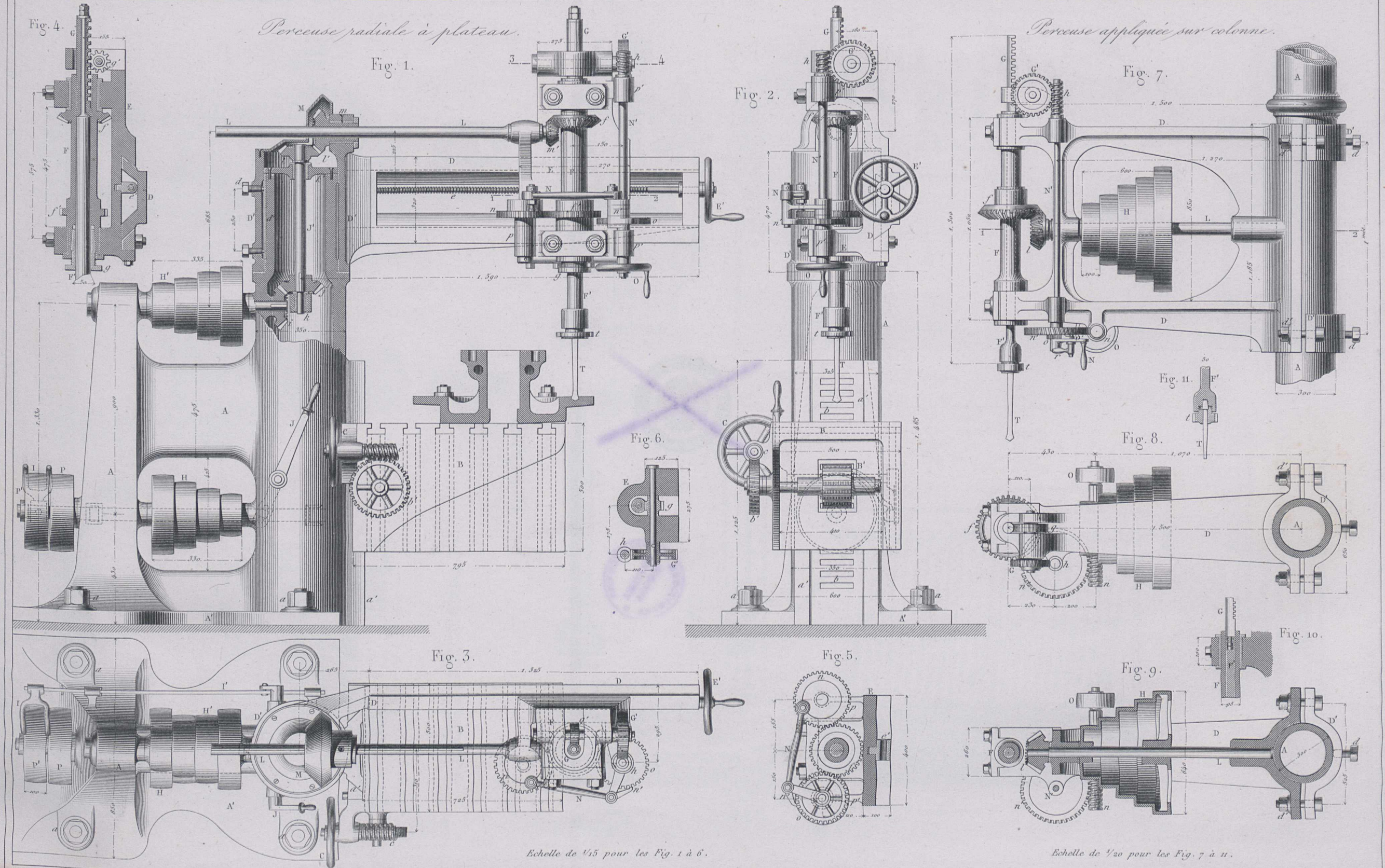

Fig. 1.

Fig. 2.

Fig. 7.

Fig. 6.

Fig. 11.

Fig. 8.

Fig. 3.

Fig. 5.

Fig. 10.

Fig. 9.

Echelle de 1/15 pour les Fig. 1 à 6.

Echelle de 1/20 pour les Fig. 7 à 11.



Presse Sterhydraulique.

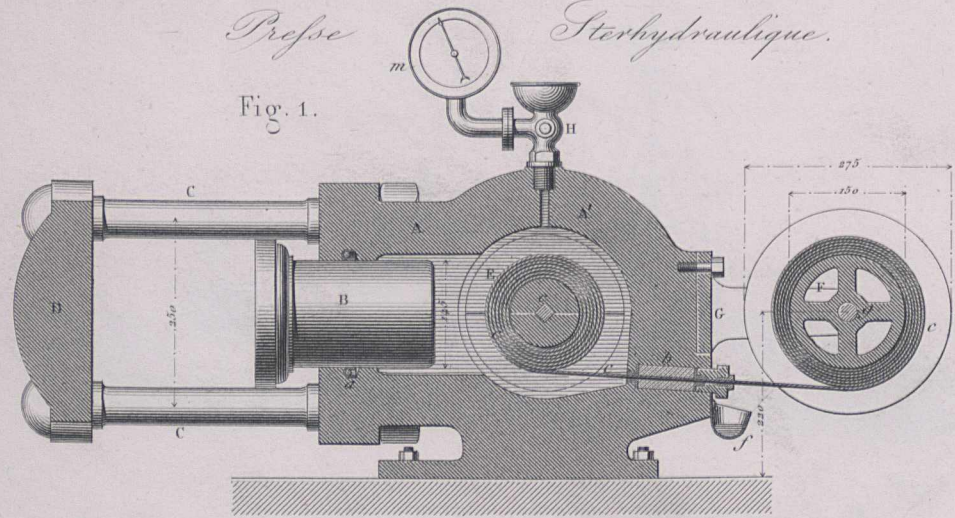

Fig. 1.

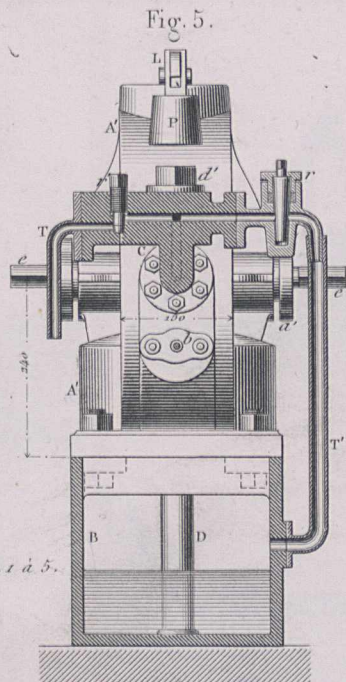

Fig. 5.

Pompe Sterhydraulique.

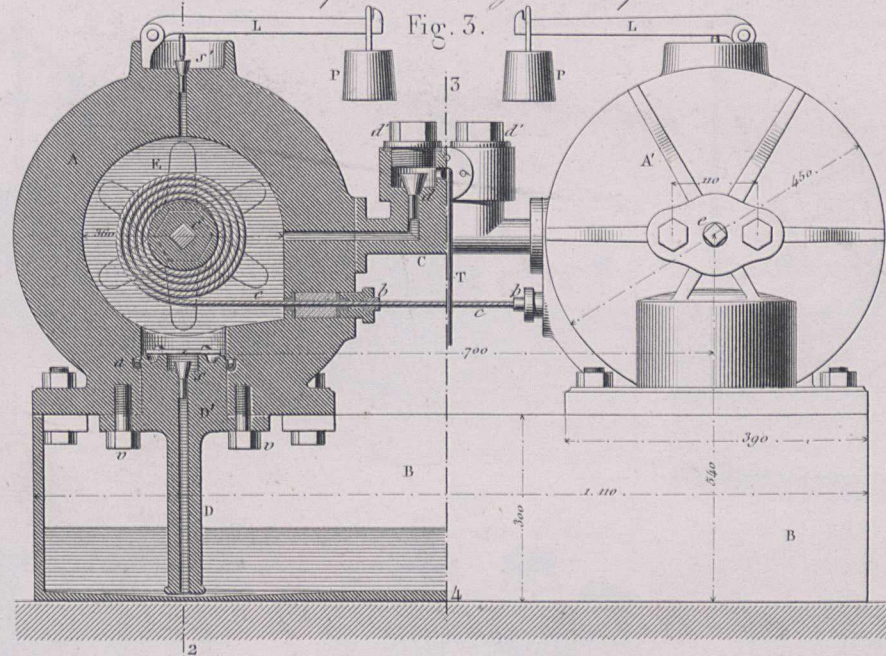

Fig. 5.

Fig. 4.

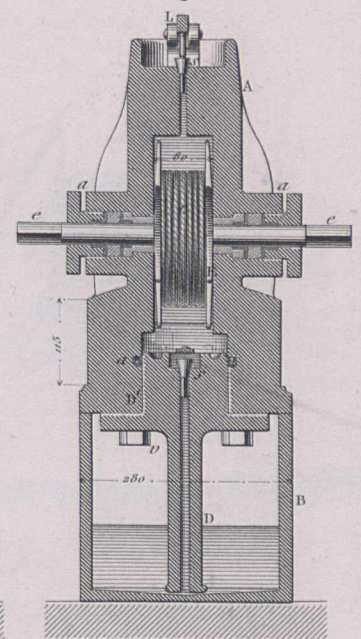
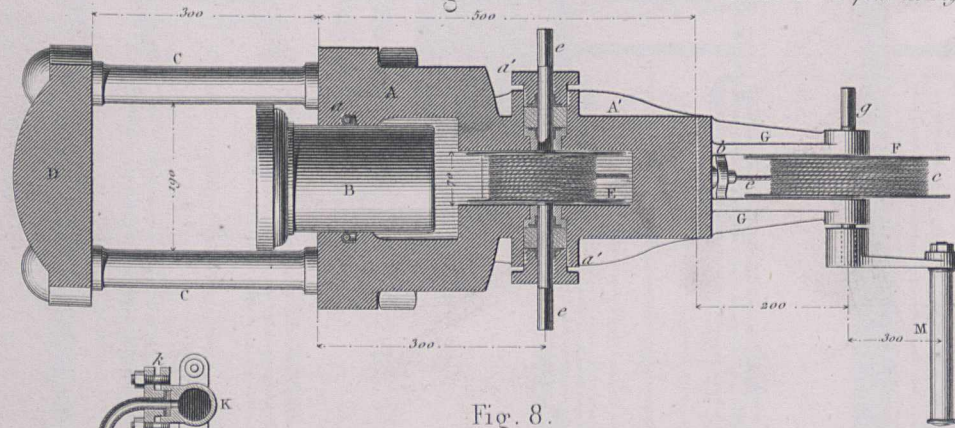

Fig. 2.

Echelle de 1/10 pour les Fig. 1 à 5.



Presse chauffée à la vapeur, par la S. J. Cockerill.

Echelle de 1/30.

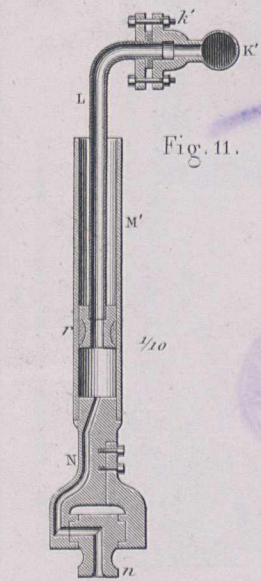

Fig. 11.

Fig. 6.

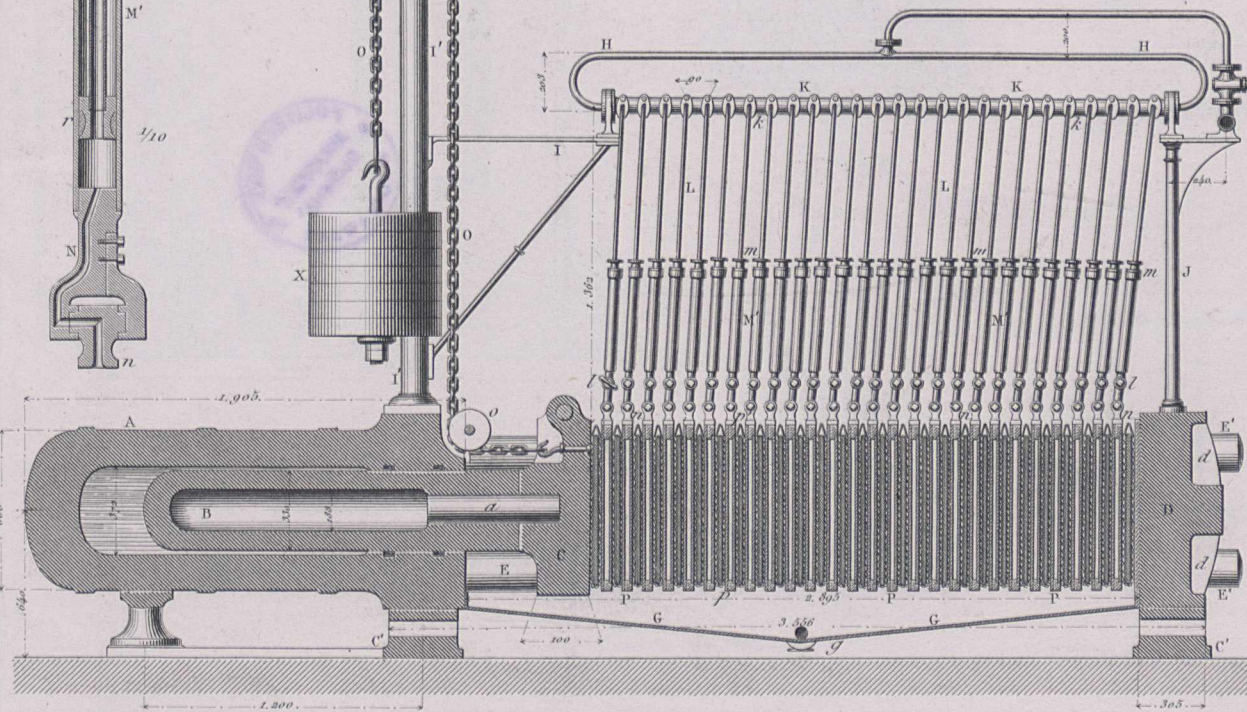

Fig. 7.

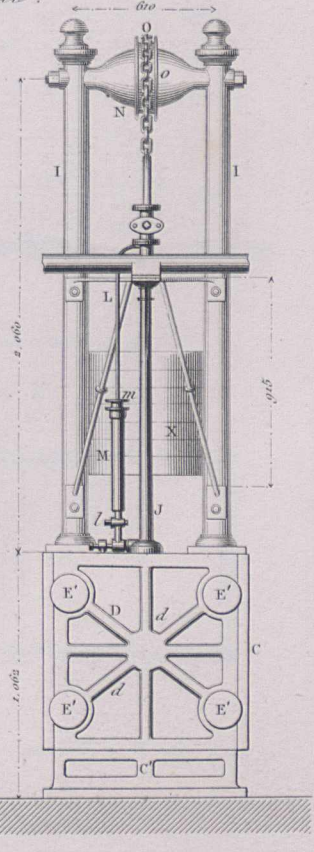

Fig. 8.

Fig. 9.

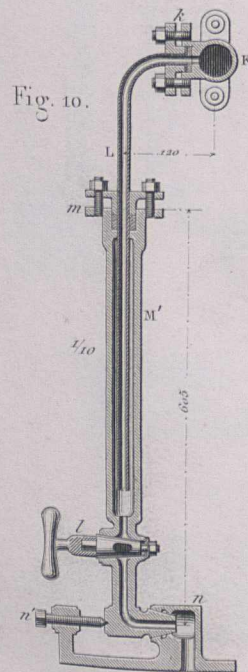
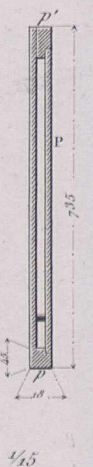
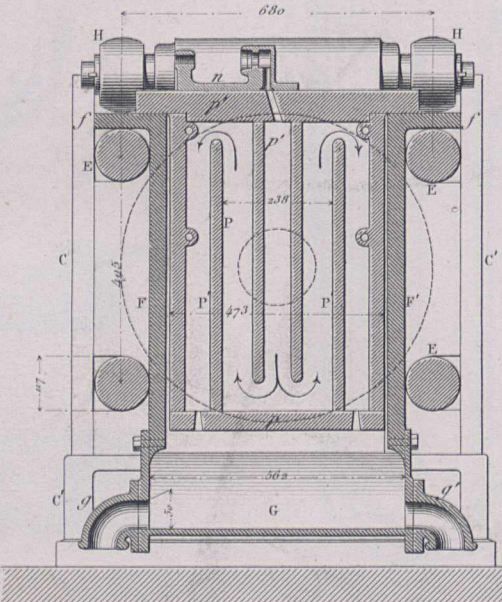

Fig. 10.



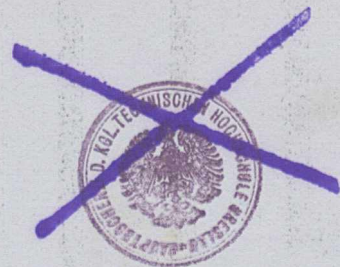
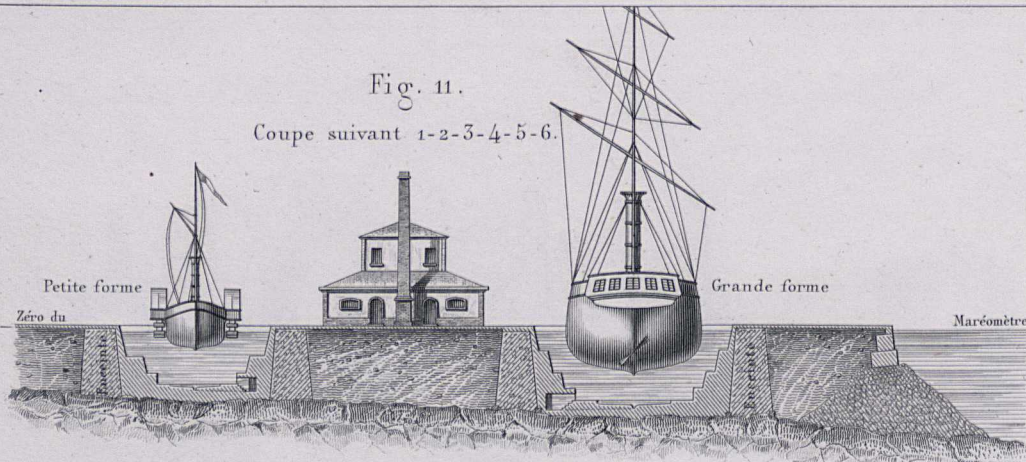

Fig. 11.
Coupe suivant 1-2-3-4-5-6.



Montage, lancement et échouage des Caisse-jalons.

Fig. 2.

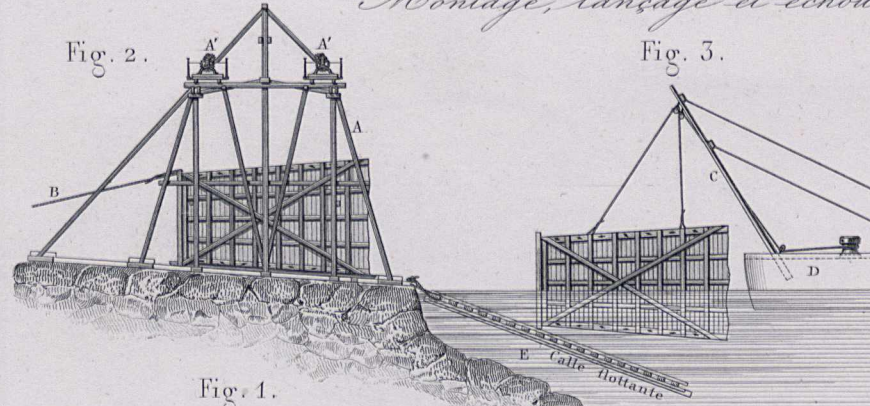

Fig. 3.

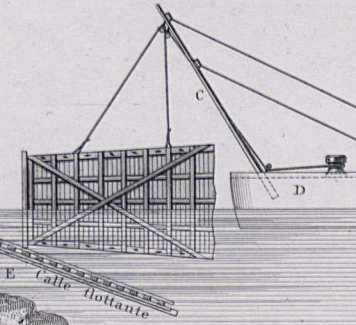

Fig. 4.

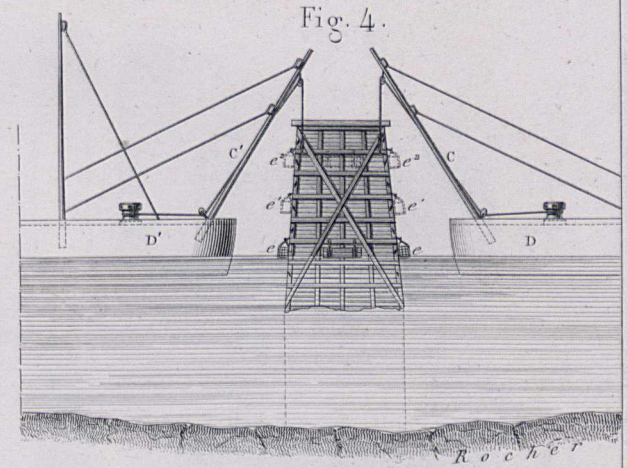

Fig. 1.

Encintes des Formes.

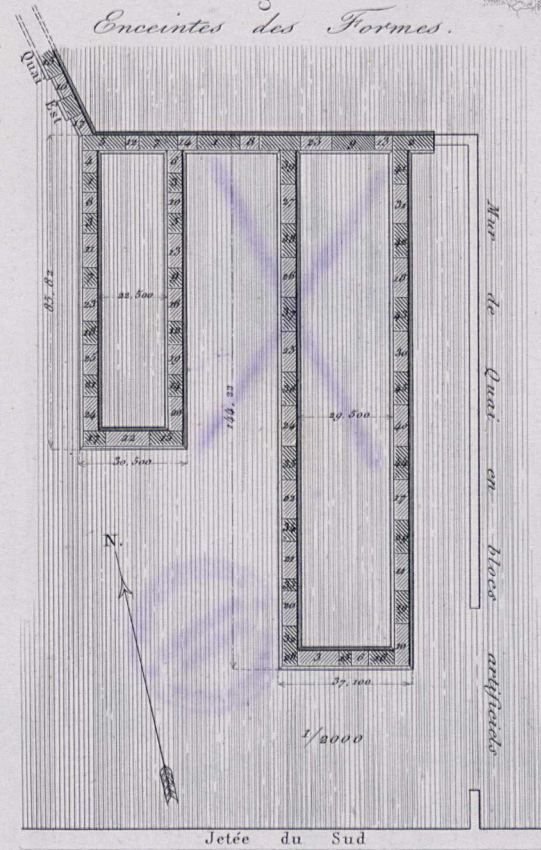

Fig. 7.

Coulage du béton.

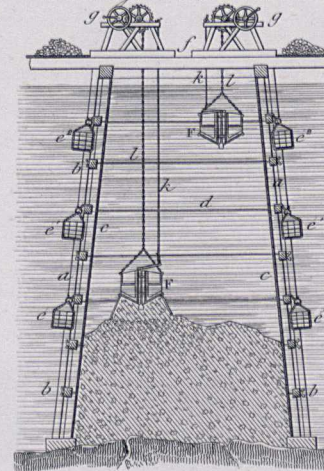

Fig. 5.

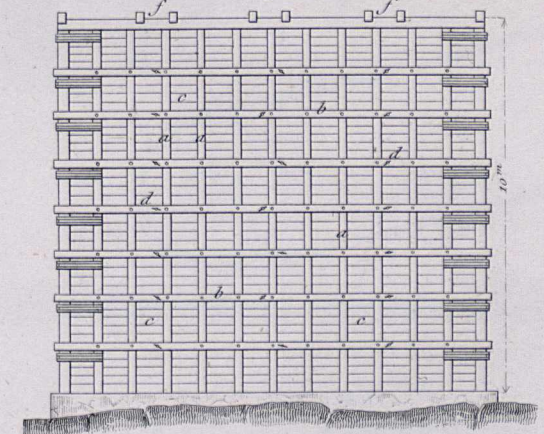

Fig. 12.

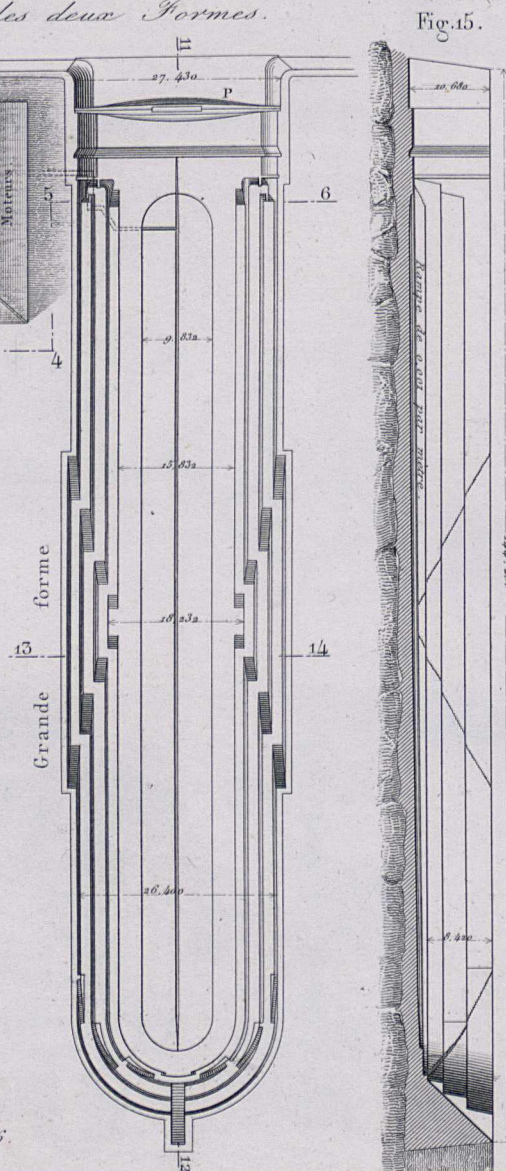

Fig. 15.

Coupe longitudinale suivant 11-12.

Fig. 14.

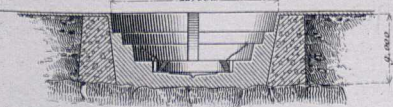
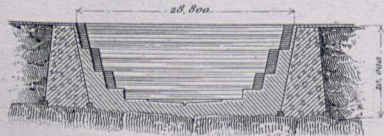

Fig. 16.



Echelle de 1/1000 pour les Fig. 11 à 16.

Coupe longitudinale suivant 7-8.

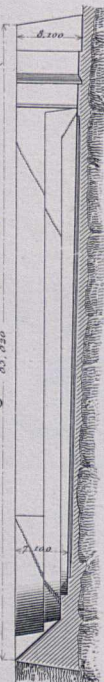
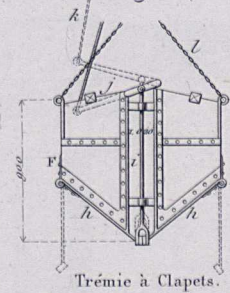

Fig. 8.



Caisse-Jalon en place.

Fig. 6.

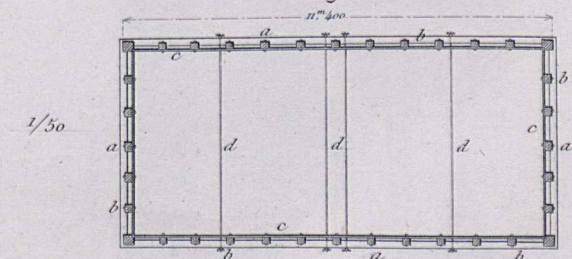

Fig. 9.

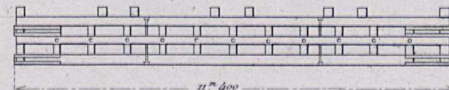
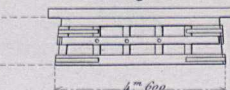

Fig. 10.



Housse de Caisse

Echelle de 1/400 pour les Fig. 2, 3 et 4.

Echelle de 1/200 pour les Fig. 5 à 7 et 9 à 10.



Machine Blake

Fig. 1.

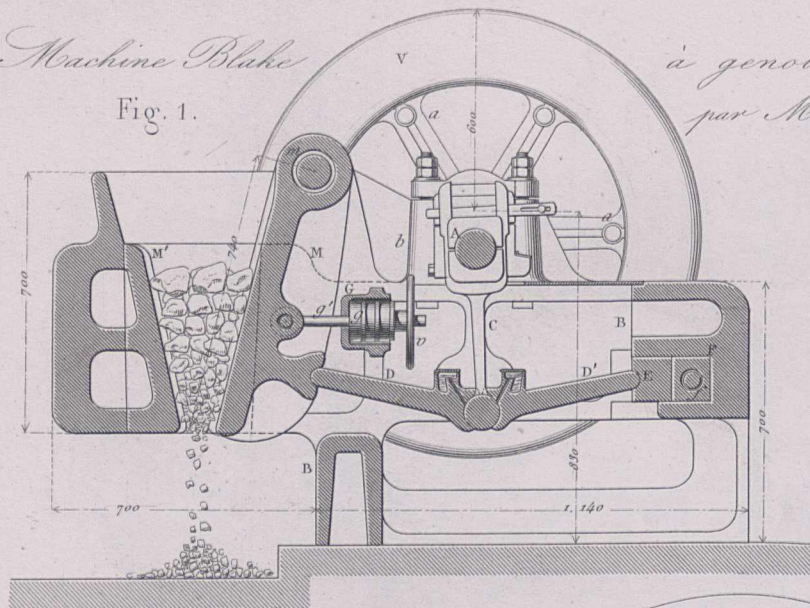

à genouillère
par M. Avery

Fig. 2.

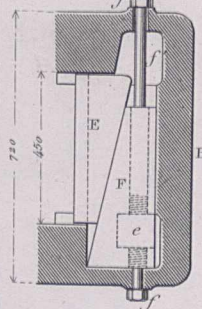

Système à mâchoire simple.

Fig. 3.

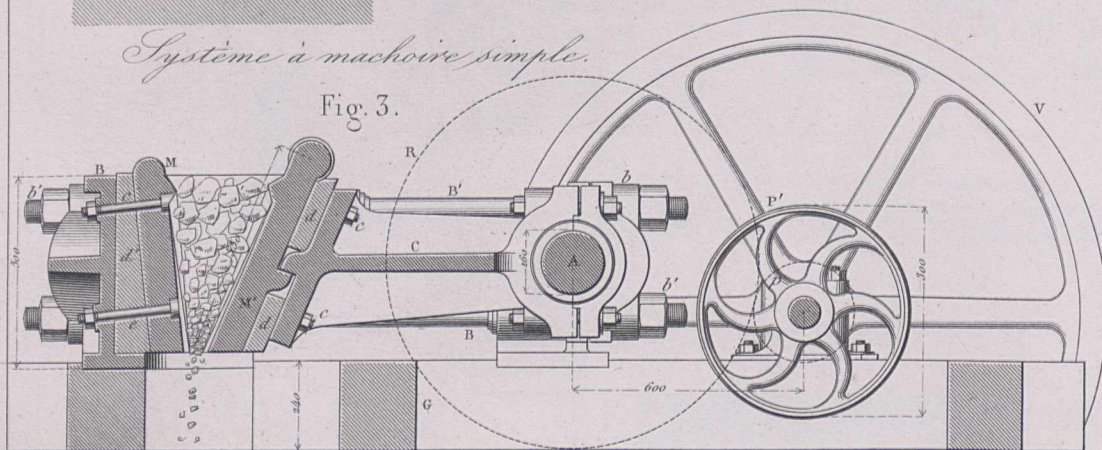

Fig. 4.

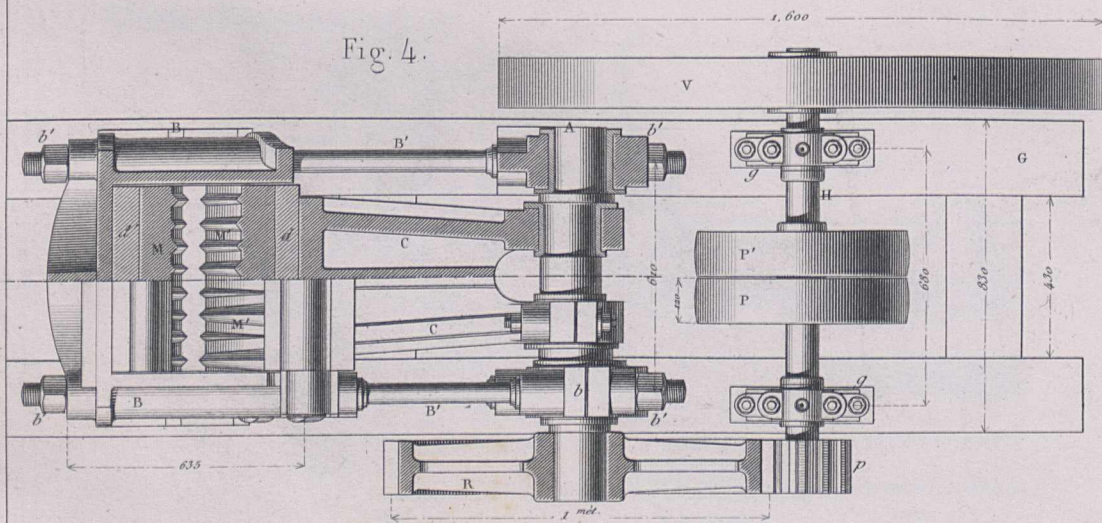
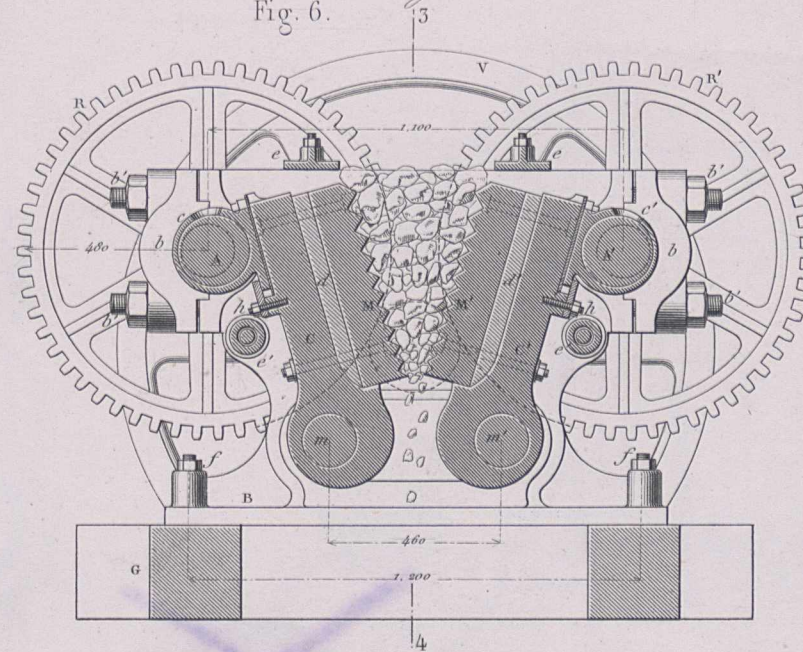

Fig. 6.

Système à deux mâchoires mobiles.



Machines de M. Dyckhoff

Fig. 5.

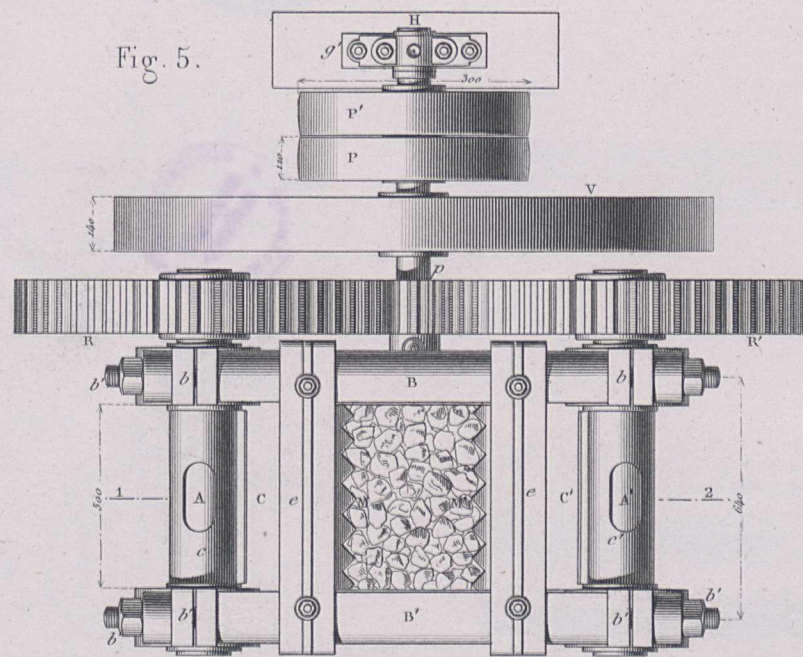

Echelle de 1/20.

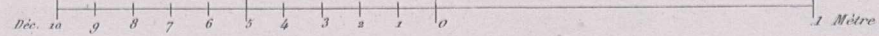
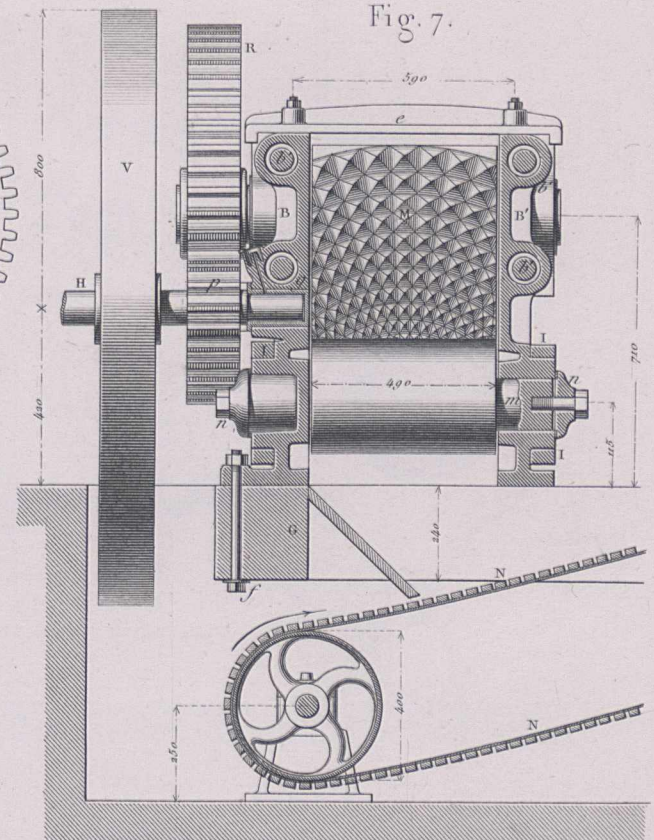
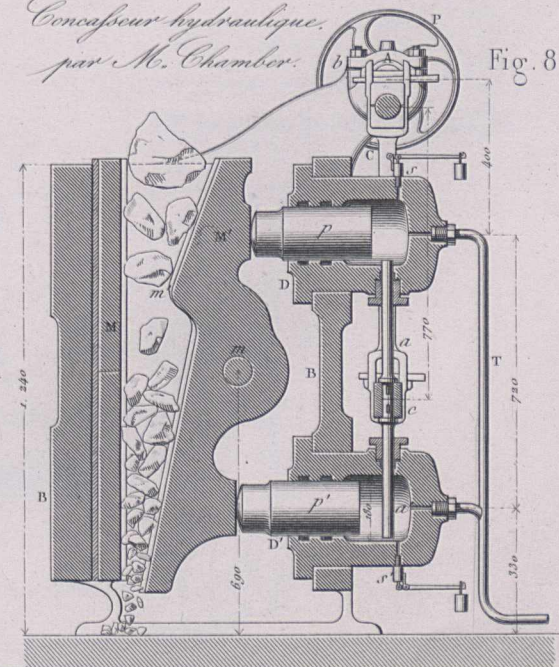

Fig. 7.



Concasseur hydraulique.
par M. Chamber.

Fig. 8.





M. Bruncaux Constructeur.

Fig. 1.

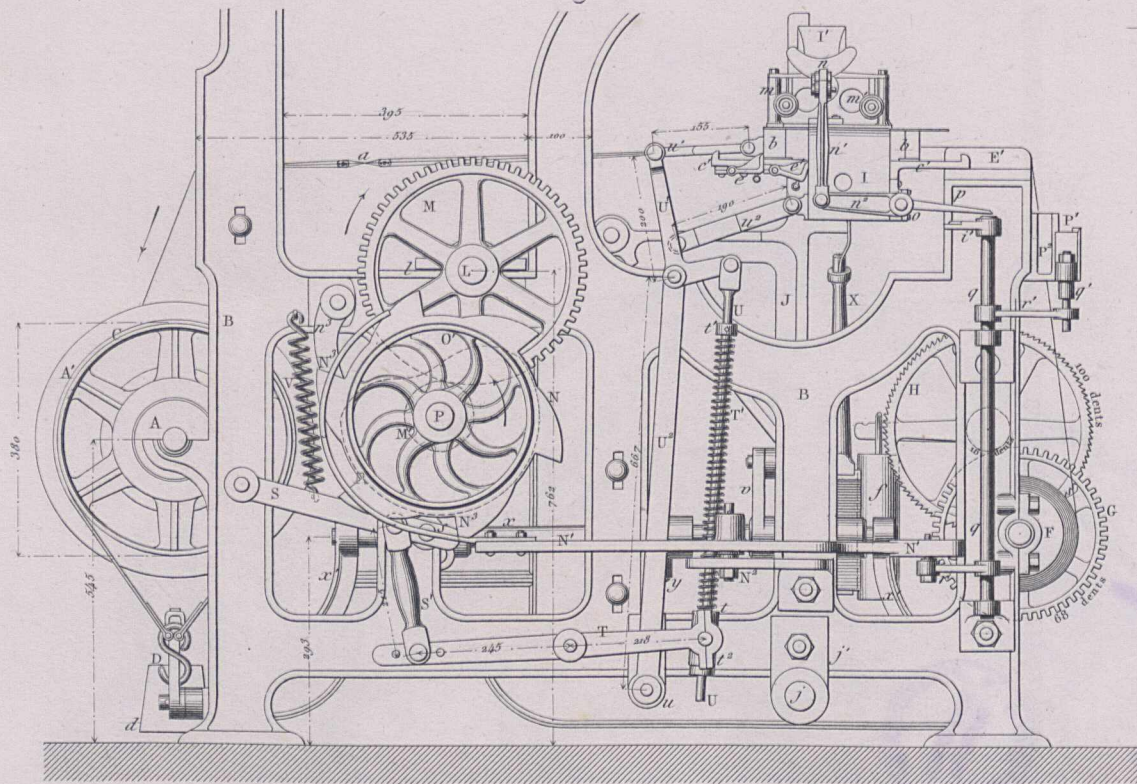

Fig. 2.

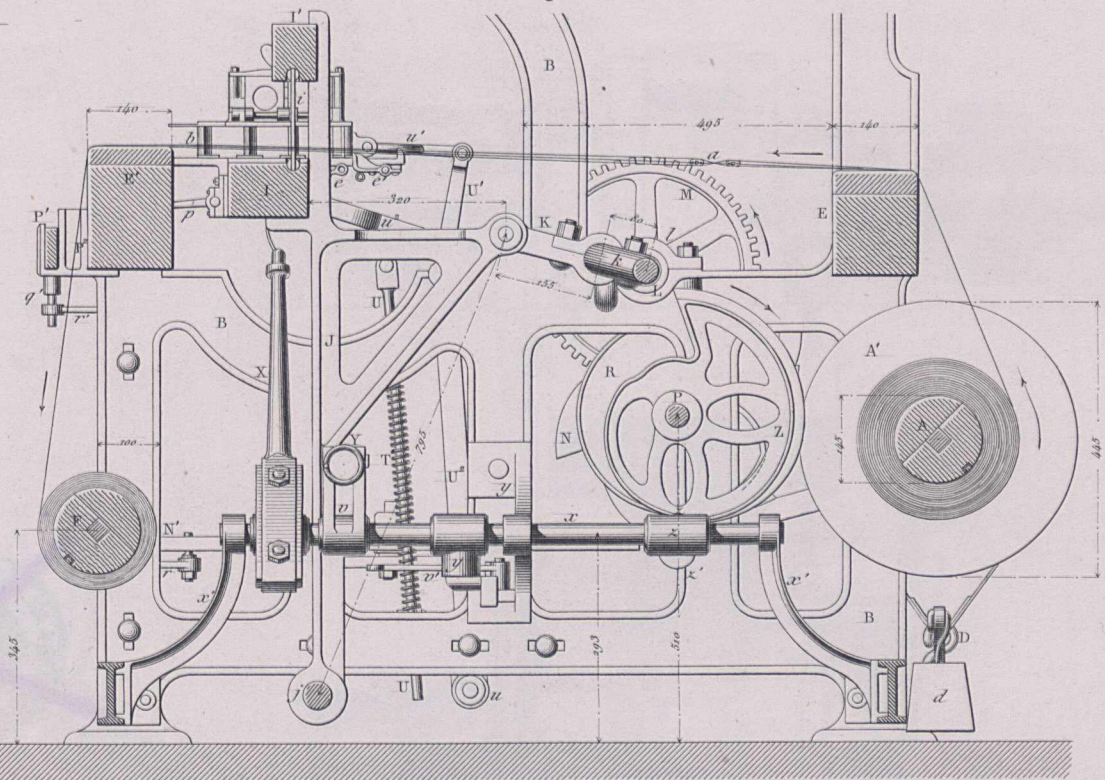

Fig. 3.

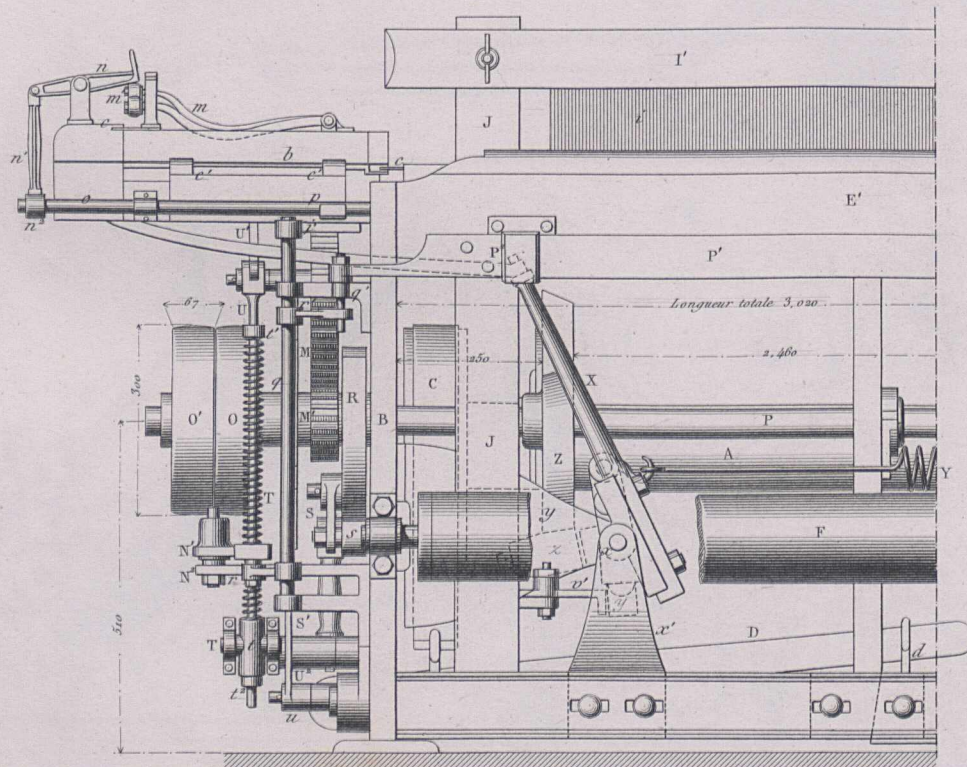

Fig. 5.

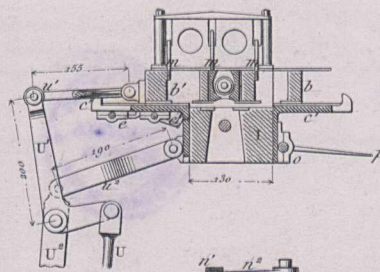
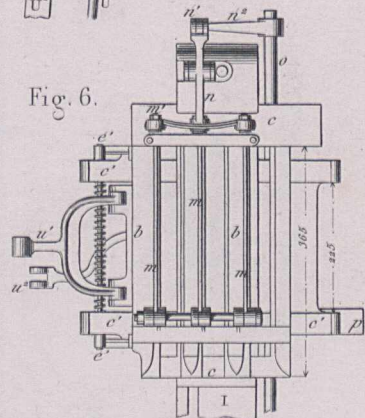

Fig. 6.



Echelle de 1/12

Fig. 4.

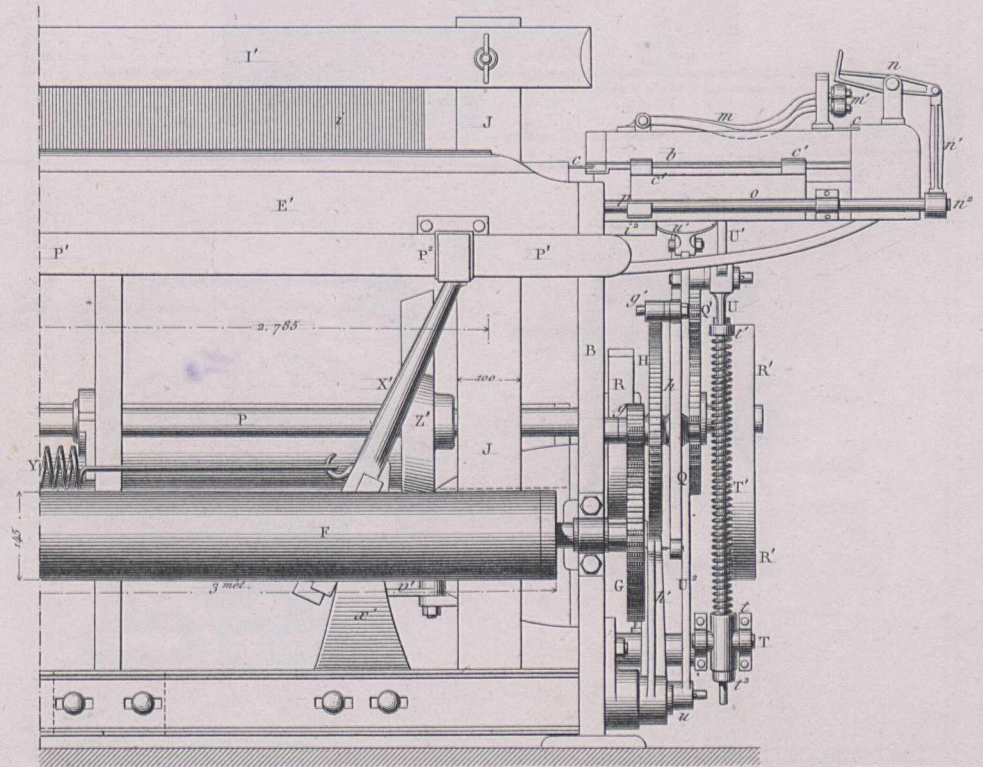



Fig. 1.

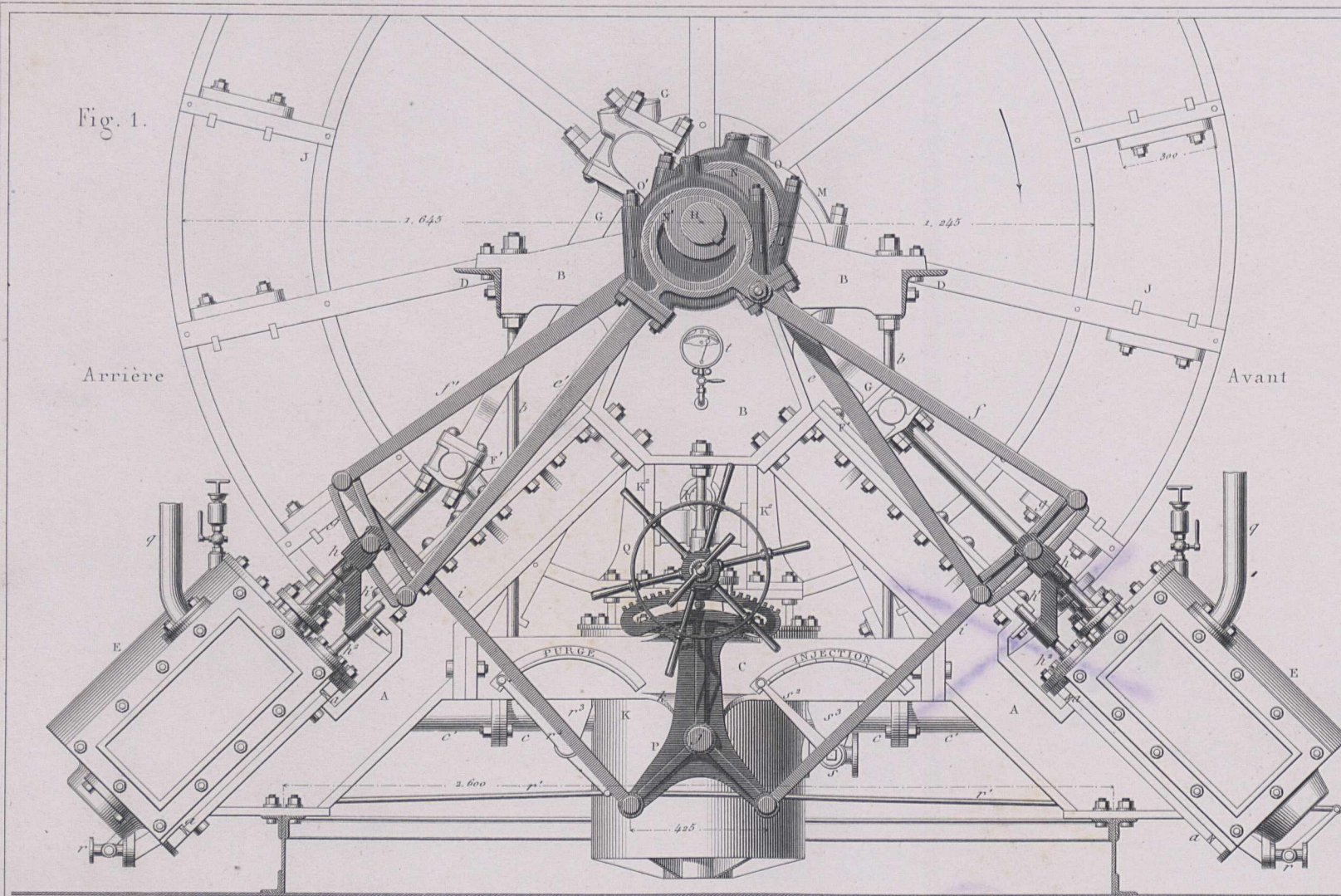

Fig. 2.

Force nominale : 30 chevaux. Vitesse : 30^t p 1'

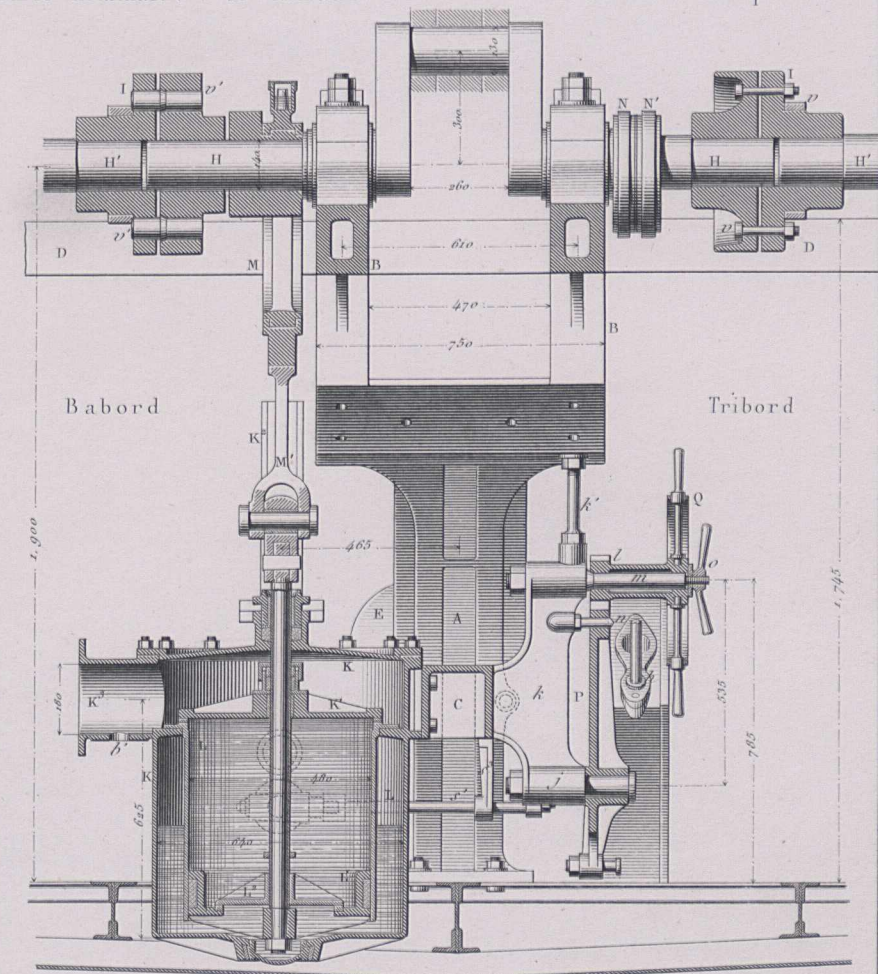

Fig. 3.

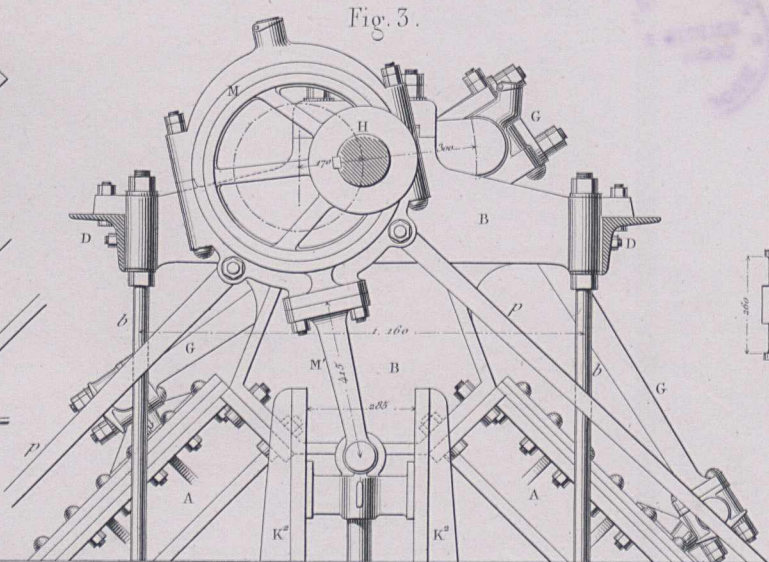

Fig. 4.

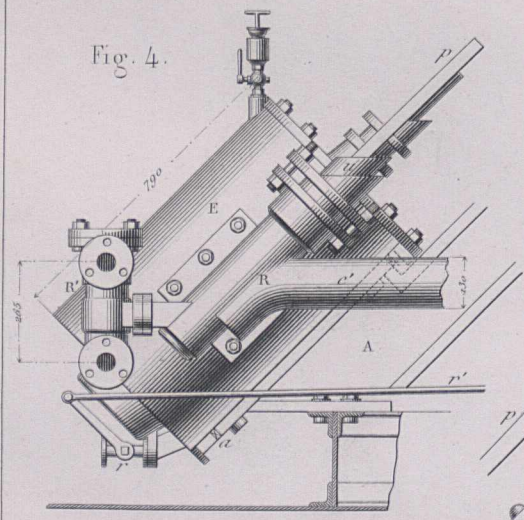
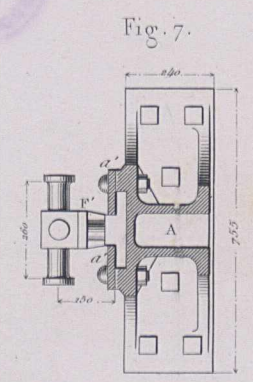

Fig. 7.



Echelle de 1/20

Fig. 5.

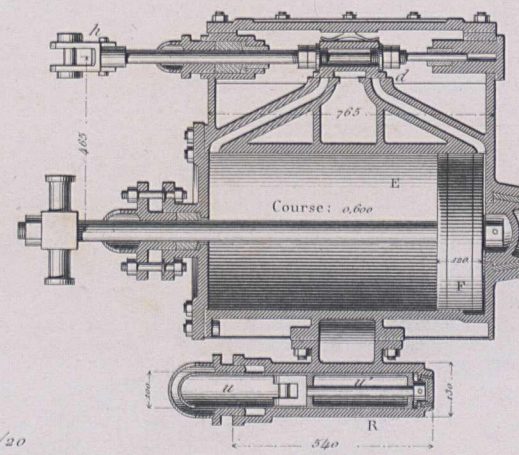
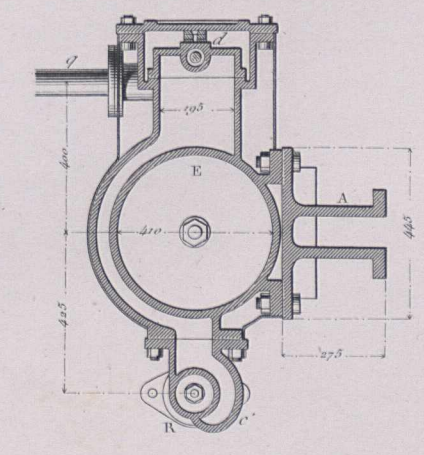
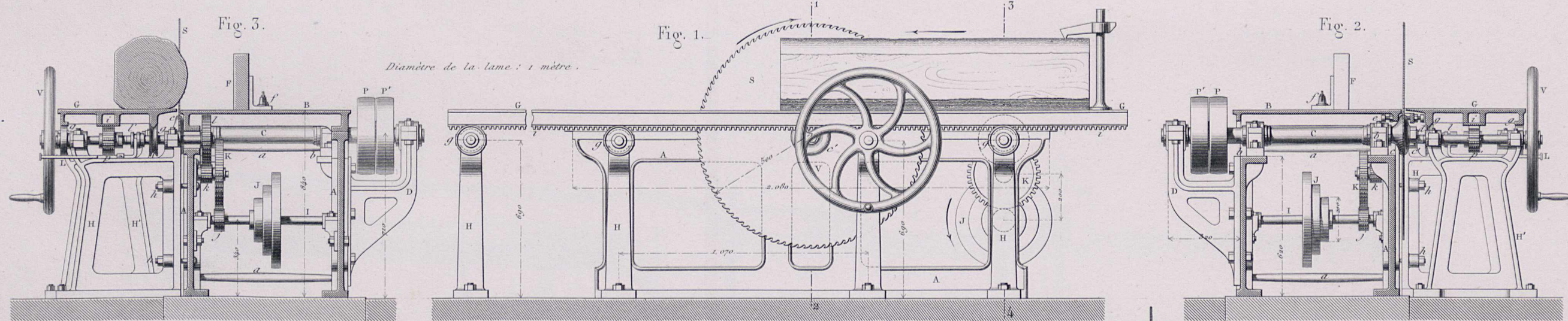

Fig. 6.





Scie à chariot pour débiter les bois ronds et équarris.



Scie à arbre mobile pour façonnage.

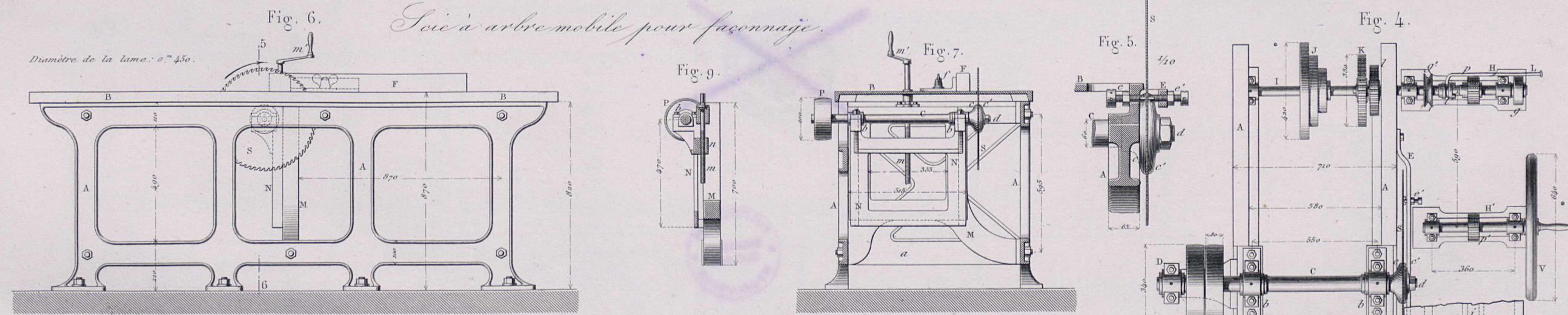

Scie à inclinaison variable.

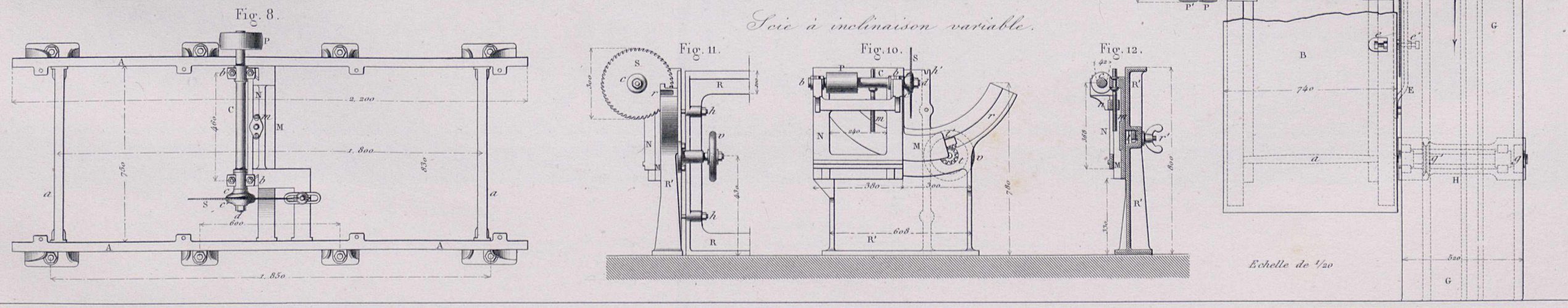

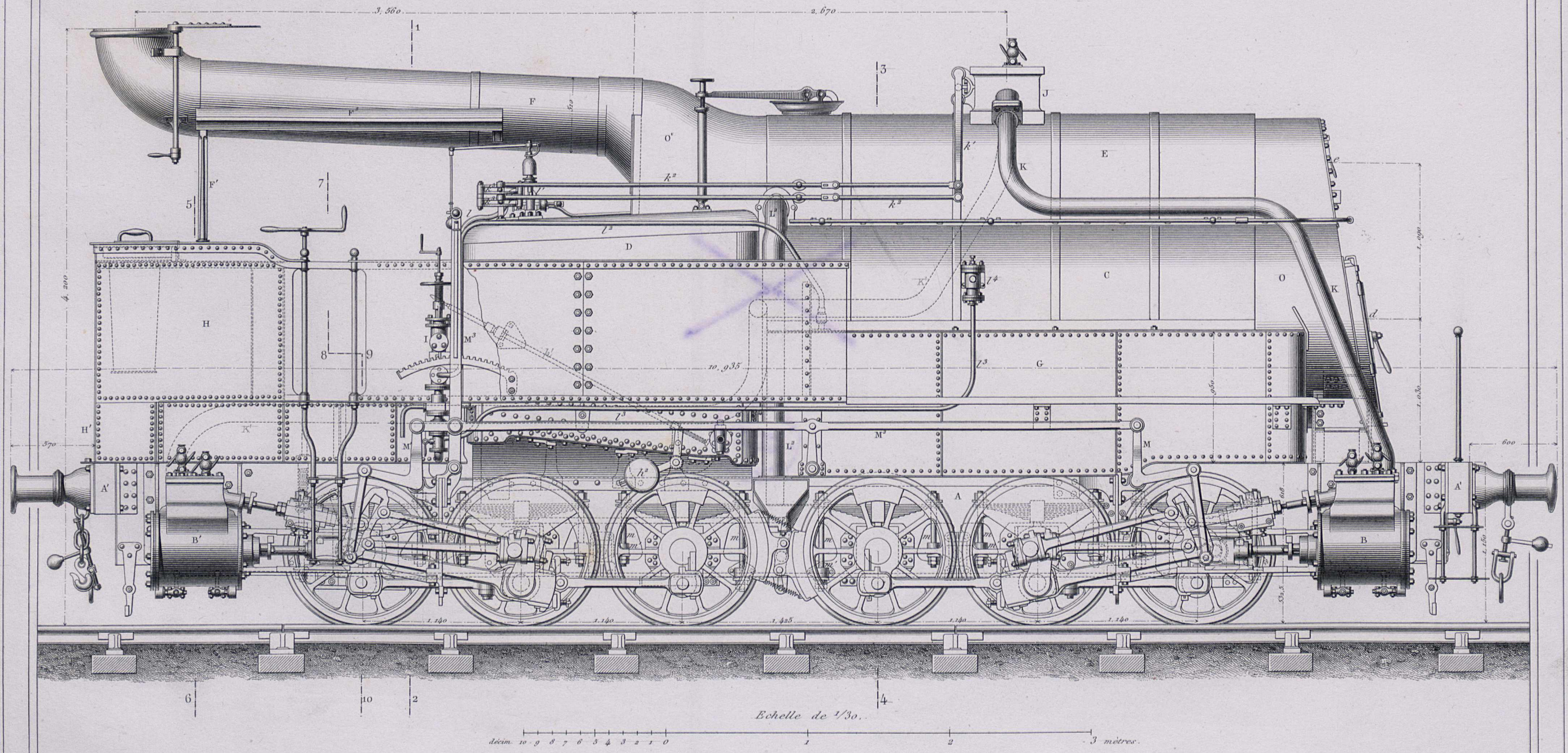

Fig. 1.

*Elevation extérieure de la machine à marchandises
à quatre cylindres et à six essieux accouplés.*

Diamètre des pistons.....0^m 440
Course.....0, 440
Diamètre des roues.....1, 065

Surface de chauffe totale.....221 m. q.
Poids total en ordre de marche.....59700 kil.
Effort de traction.....8000 kil.





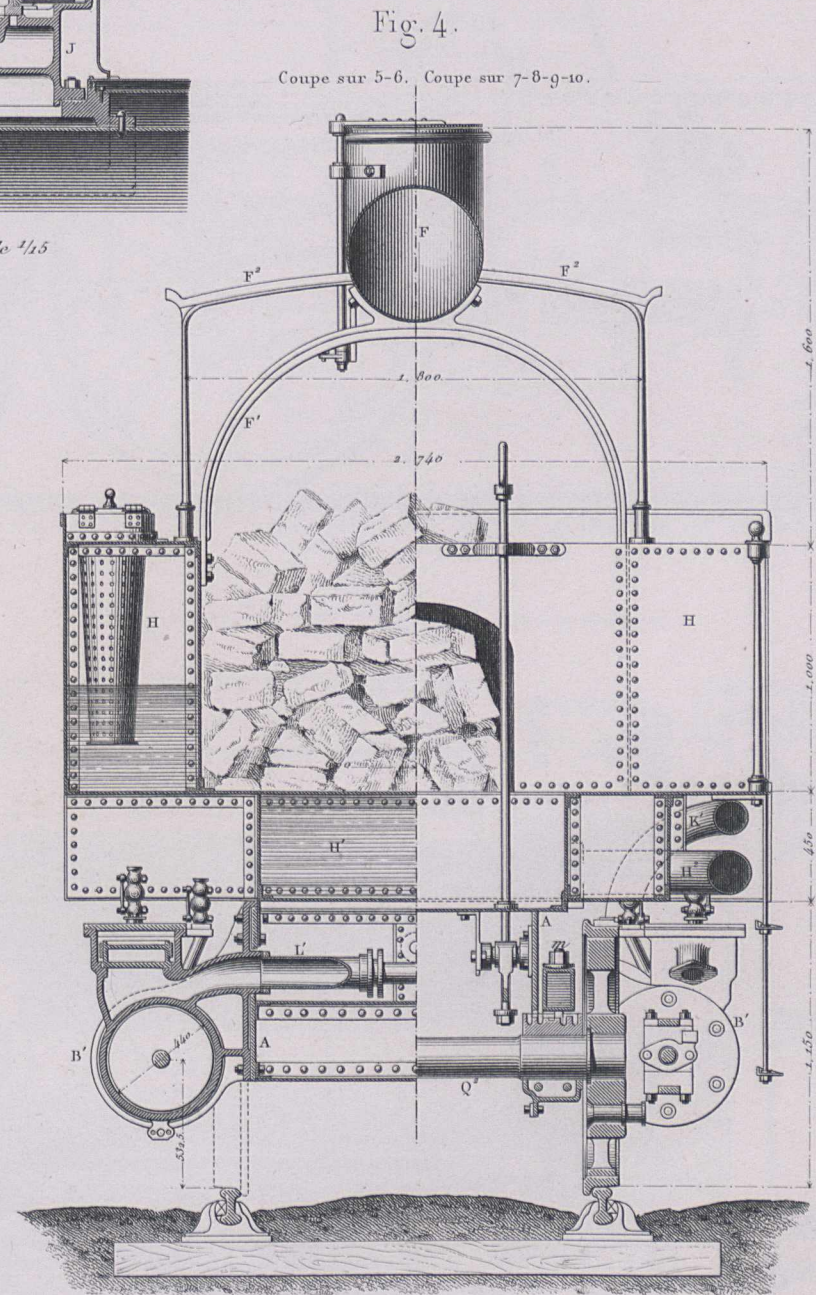
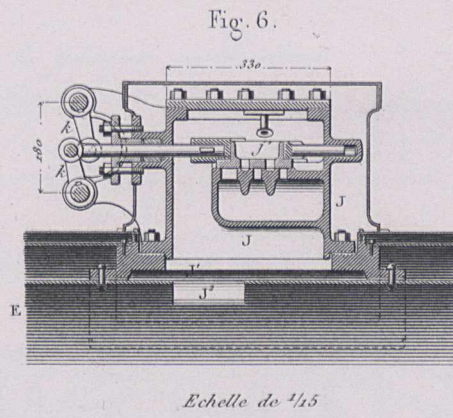
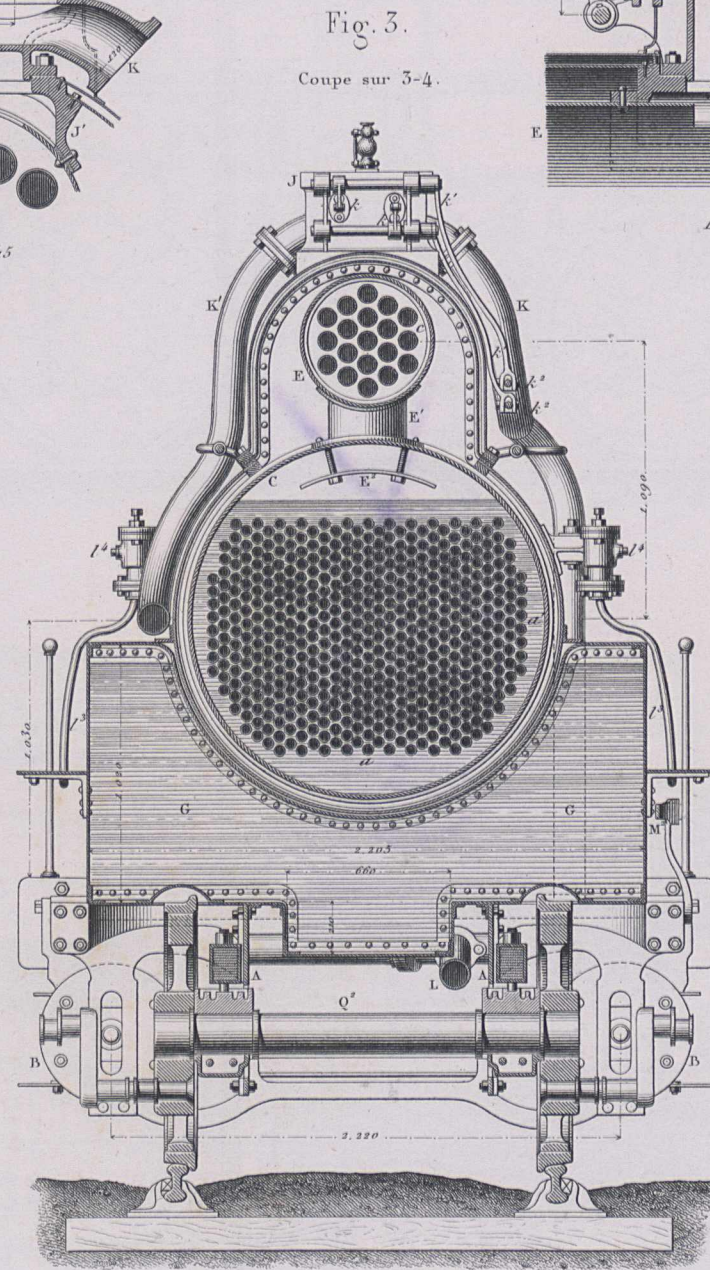
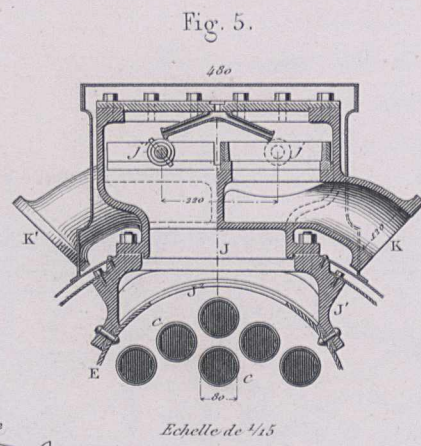
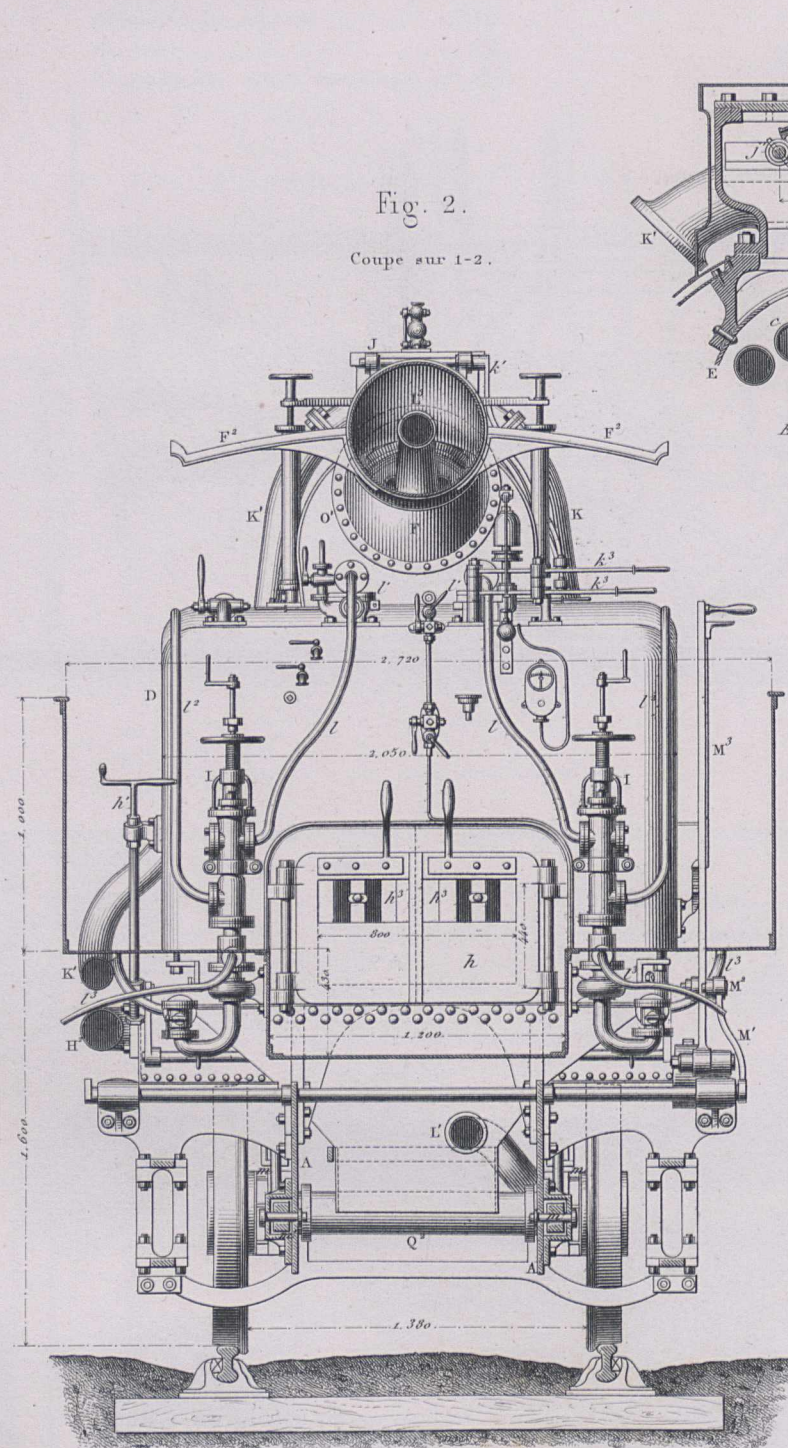

Echelle de 1/30 pour les Fig. 2, 3 et 4.

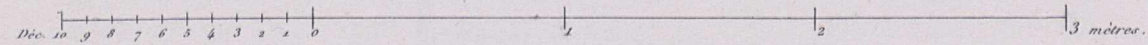



Diamètre des pistons..... 0^m 360
Course..... 0, 340
Diamètre des roues motrices..... 1^m 600

Fig. 12.

Mécanisme de la machine à voyageurs, à quatre cylindres
et à deux essieux moteurs indépendants.

Surface de chauffe totale..... 167 m. q.
Poids total en ordre de marche... 48350 kil.
Effort de traction..... 3000 kil.

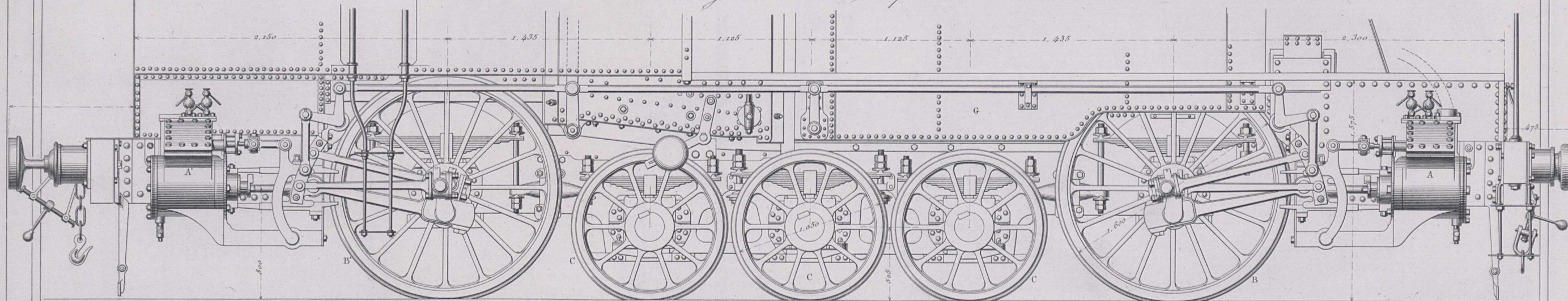

Machine à marchandises.

Fig. 7.

Projection horizontale extérieure.

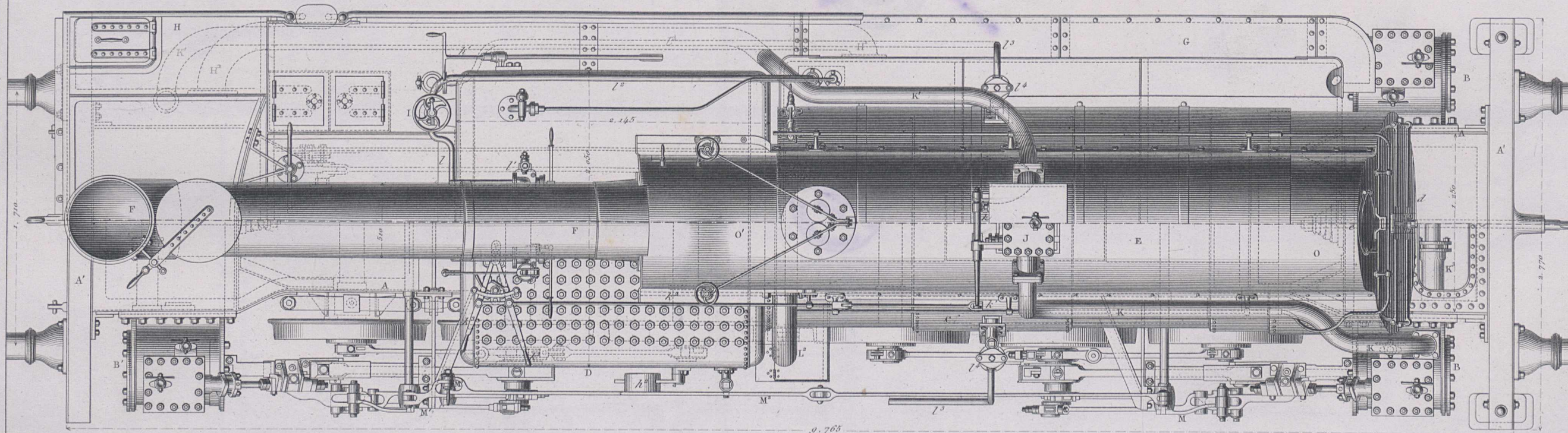

Echelle de 1/30.



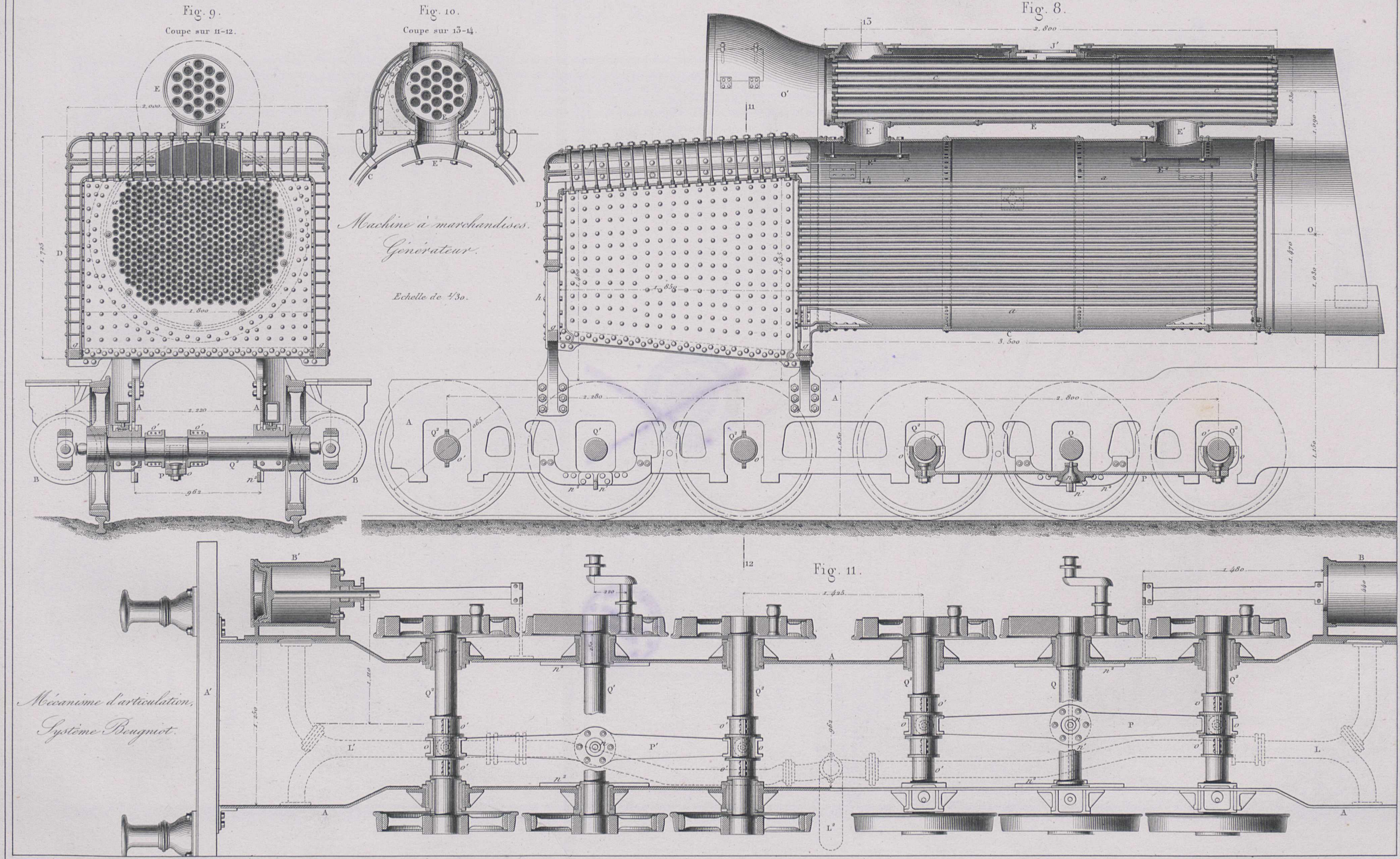
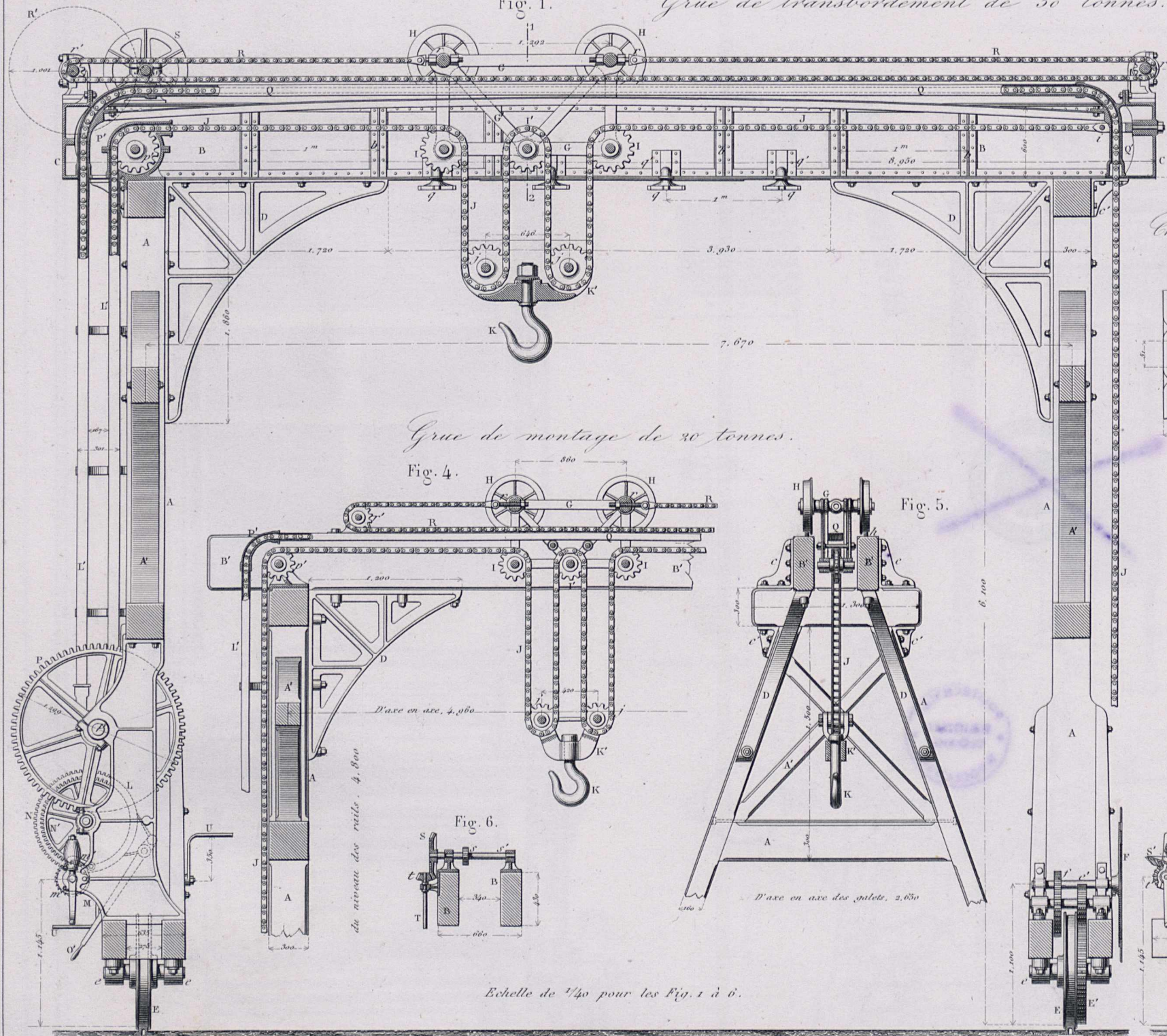



Fig. 1.

Grue de transbordement de 30 tonnes.



Grue de montage de 30 tonnes.

Fig. 4.

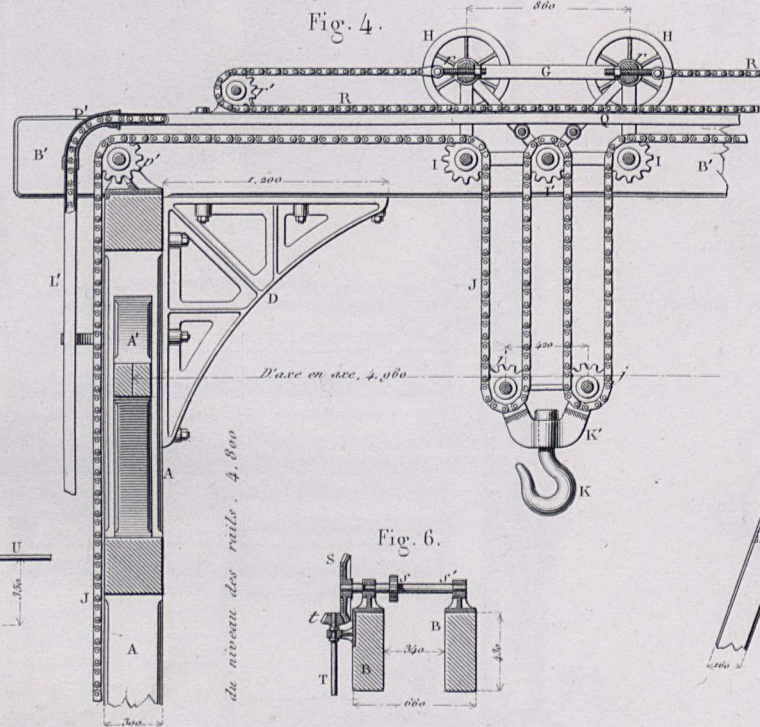

du niveau des rails. 4.850

Fig. 5.

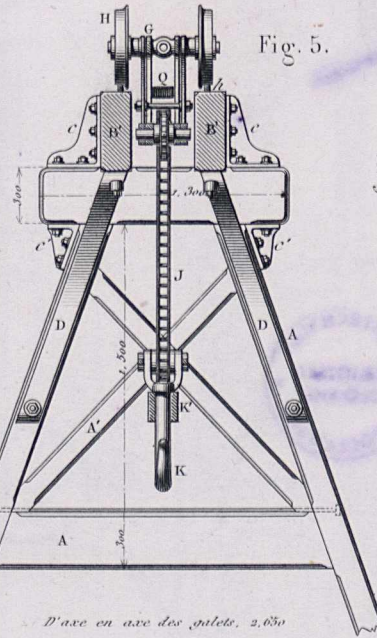

D'axe en axe des pignons, 2.650

Fig. 6.

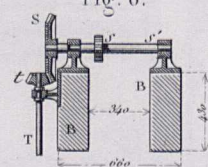

Echelle de 1/40 pour les Fig. 1 à 6.

Fig. 2.

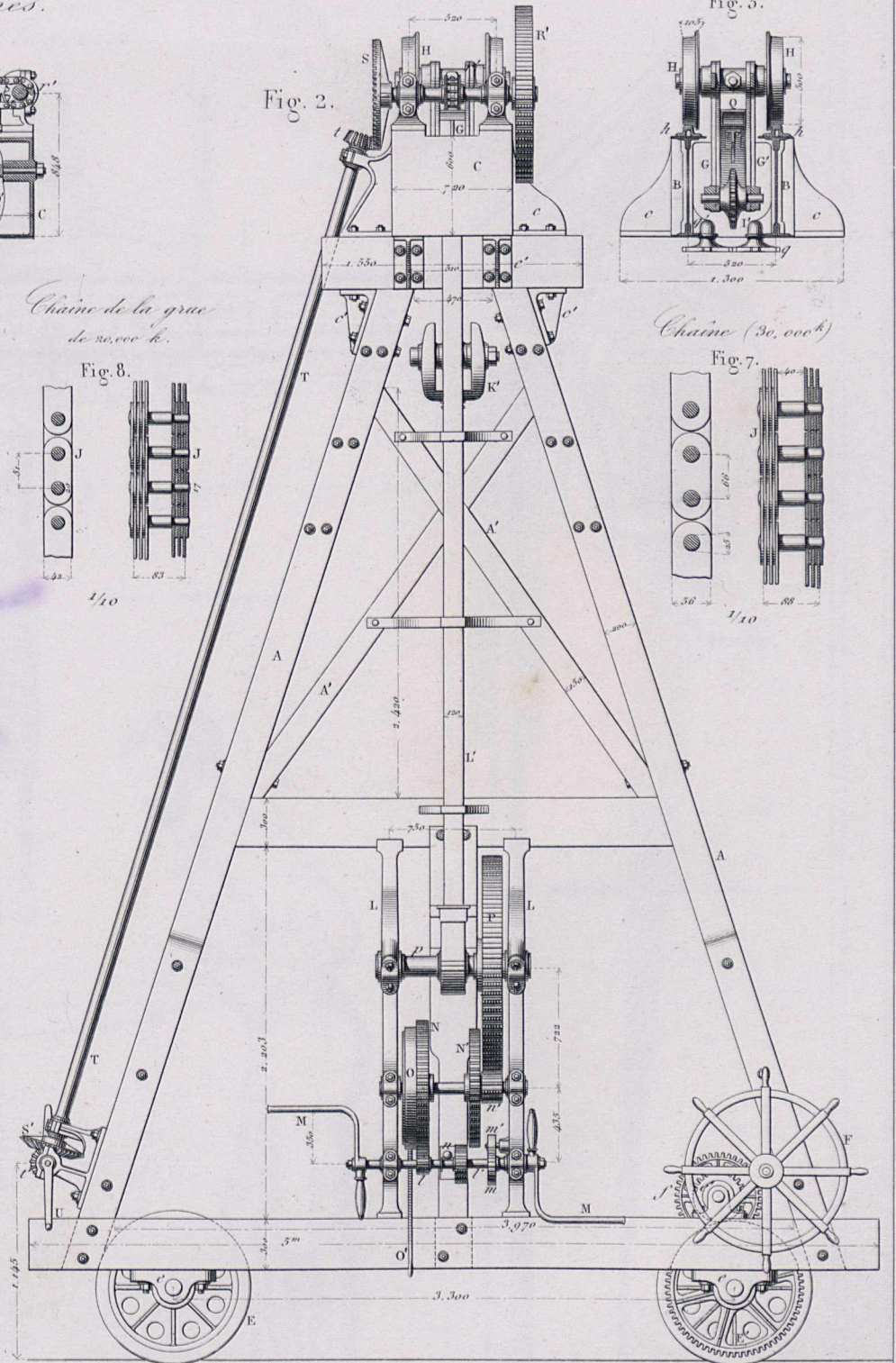

Chaîne de la grue de 30,000 k.

Fig. 8.

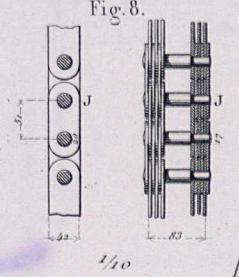
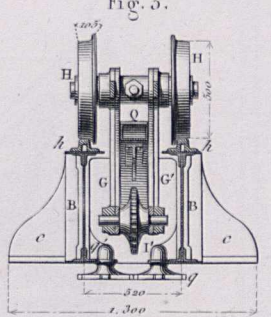
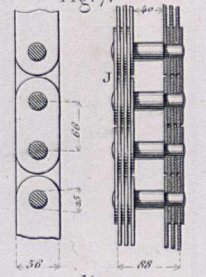

Fig. 3.



Chaîne (30,000 k)

Fig. 7.





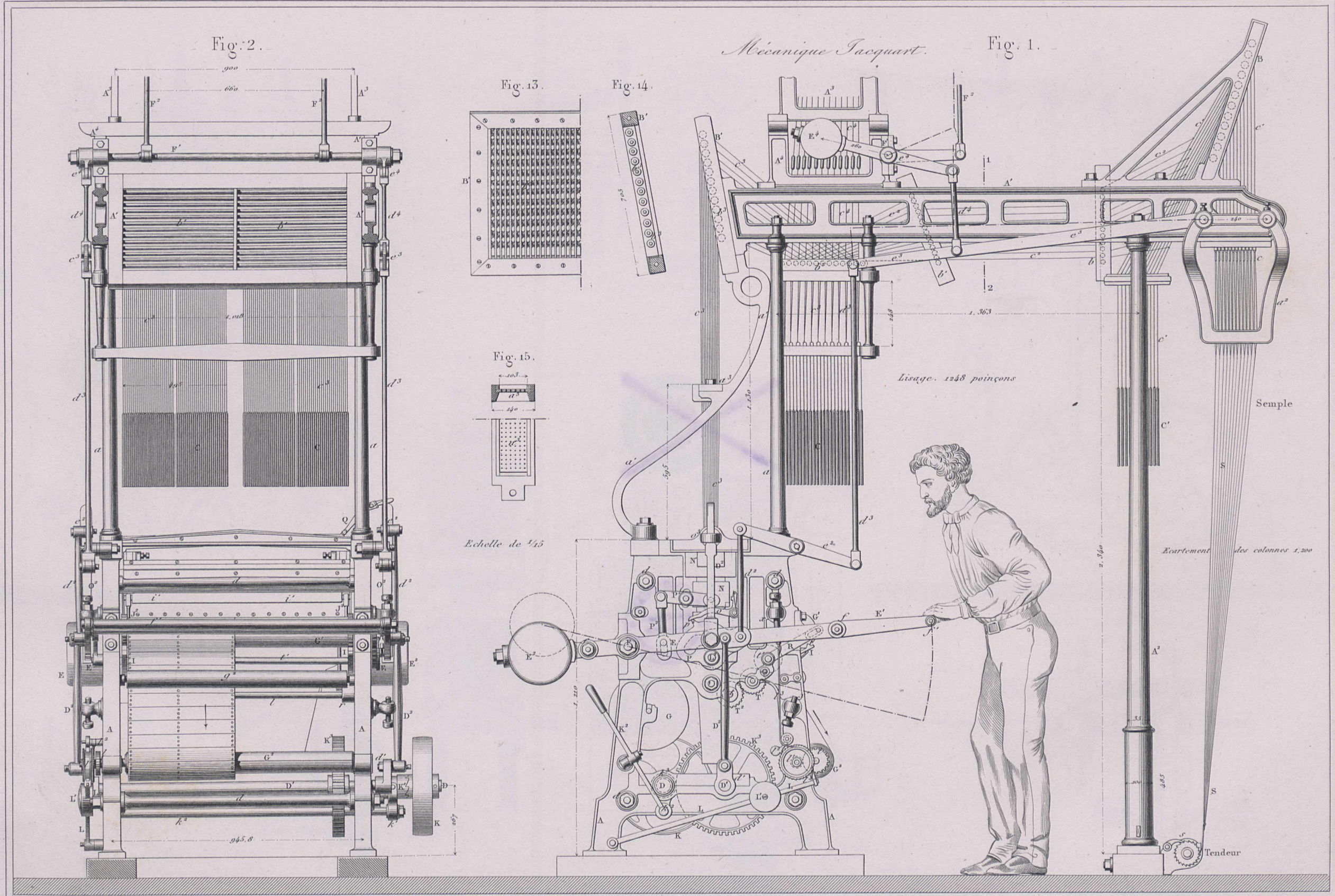



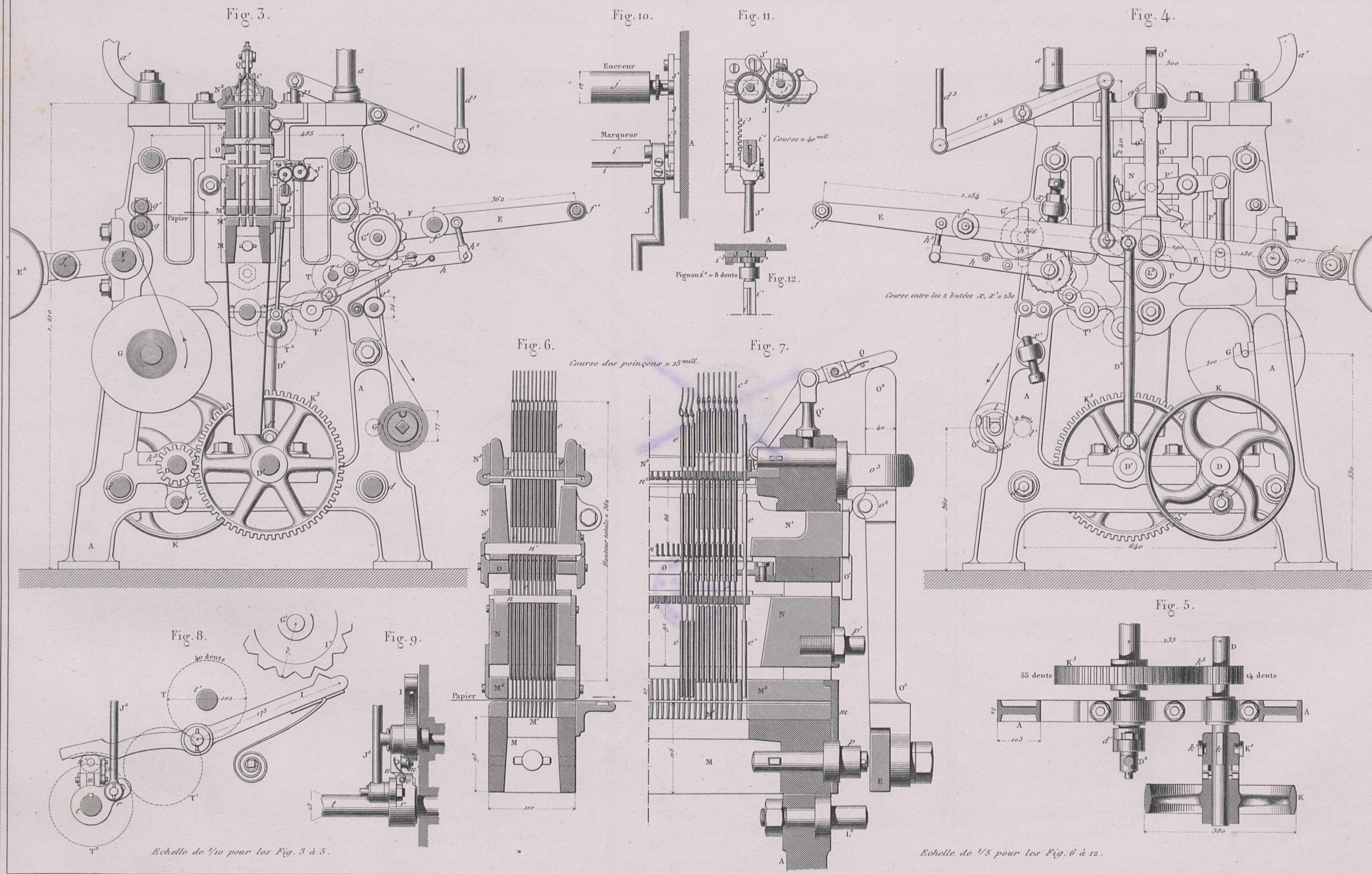



Section de la plaque soulevée par les tampons.

Fig. 1.

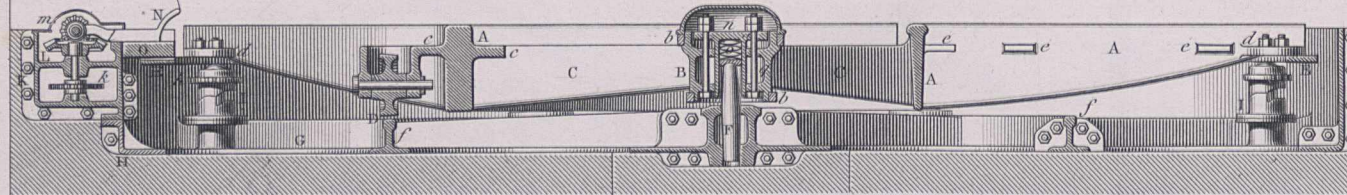

Elevation du plateau abaissé reposant sur ses galets.

Fig. 3.

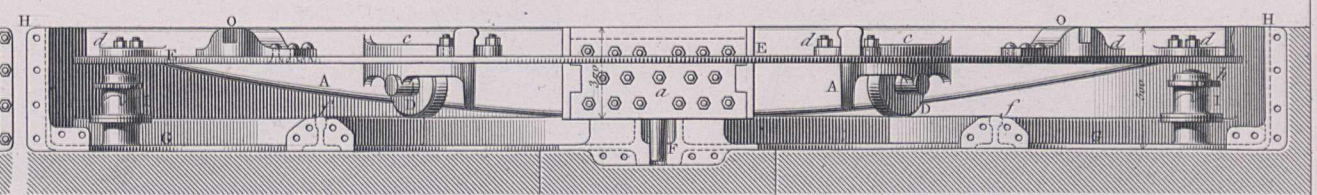
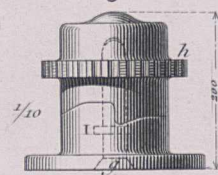

Fig. 5.



Tampon descendu.

Plan de la plaque de fondation.

Fig. 2.

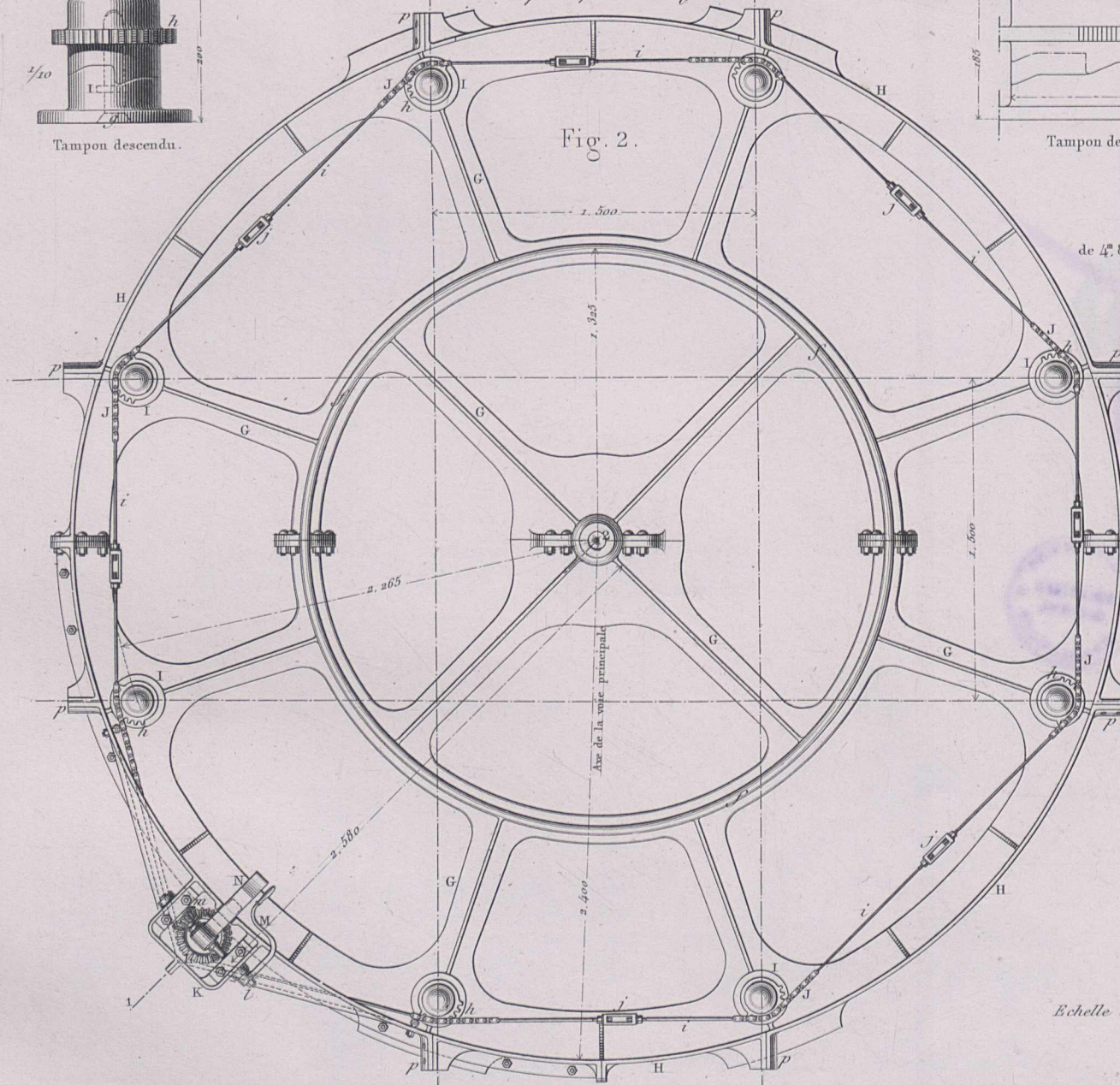
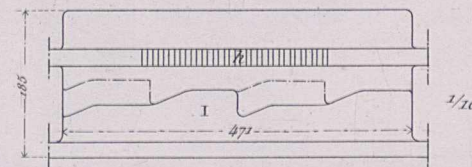

Fig. 7.



Tampon de calage développé.

Type de 4,800 de diamètre

Plan du plateau supérieur.

Fig. 4.

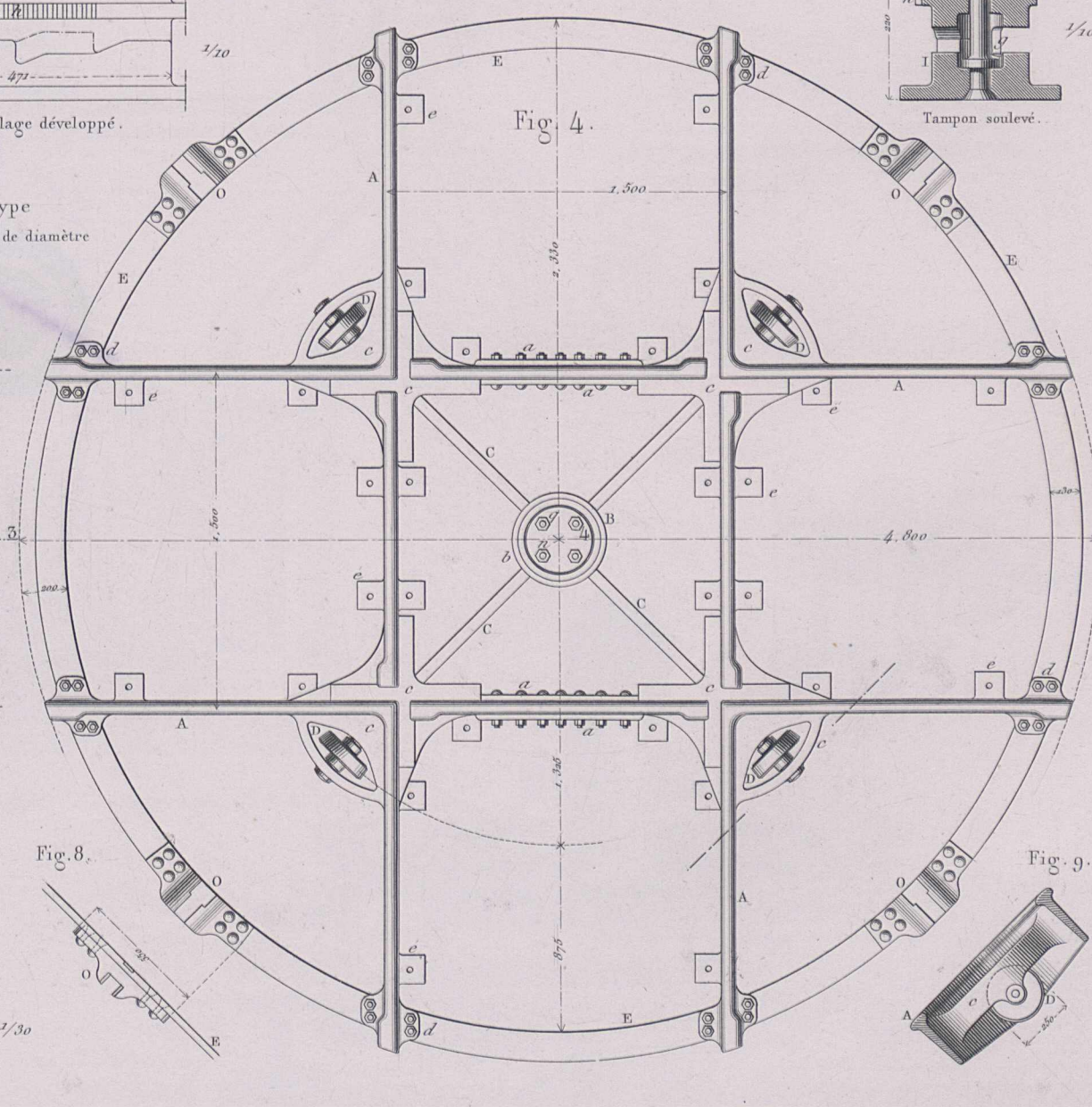
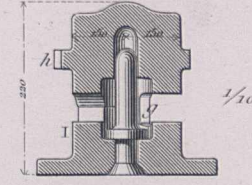
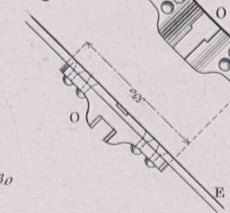

Fig. 6.



Tampon soulevé.

Fig. 8.



Echelle de 1/30

Fig. 9.

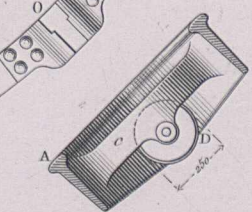



Fig. 3.

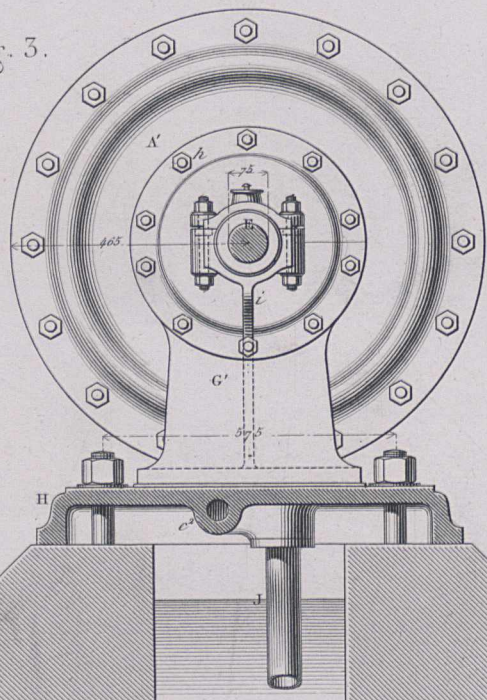

Fig. 1.

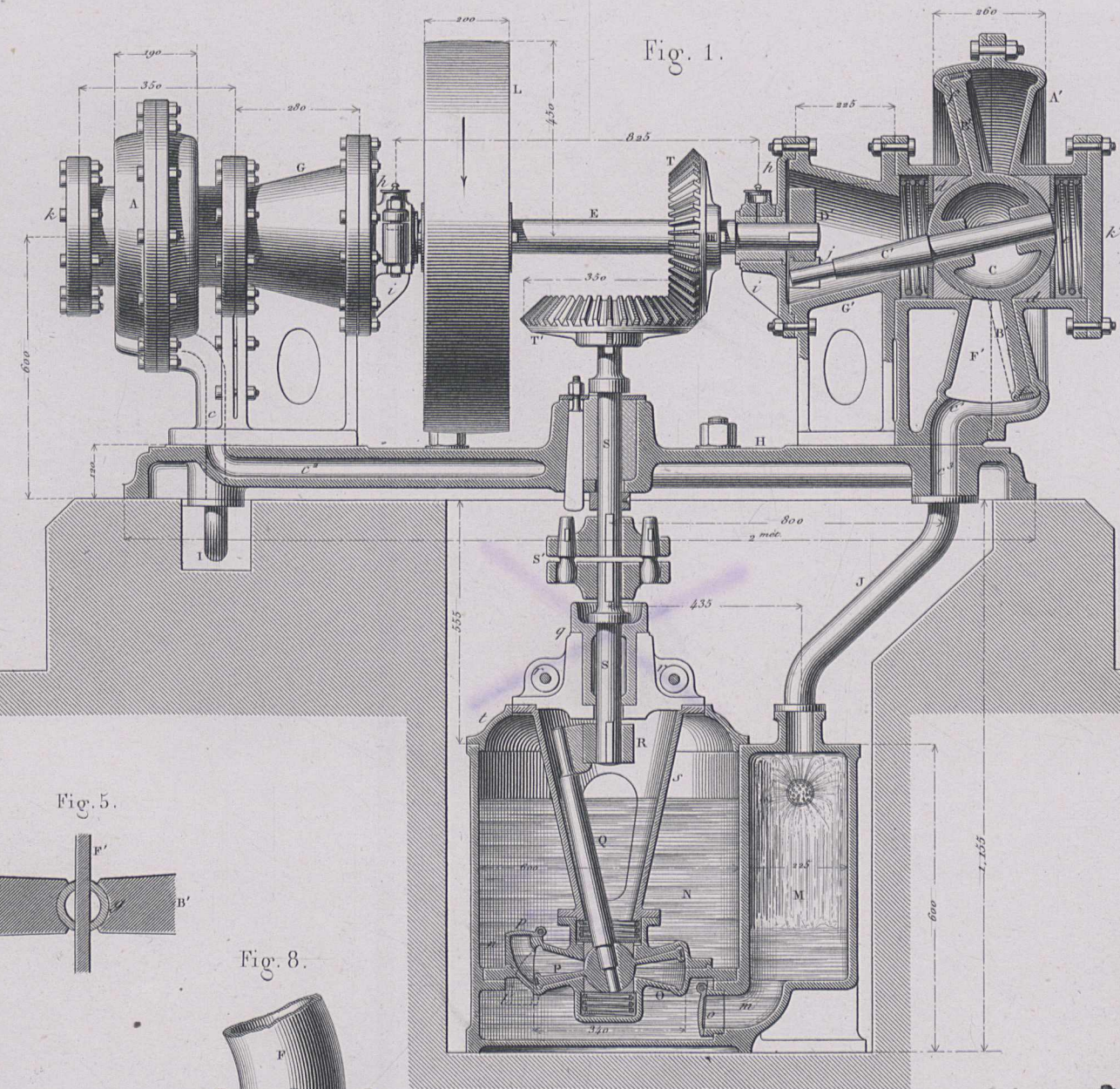

Fig. 2.

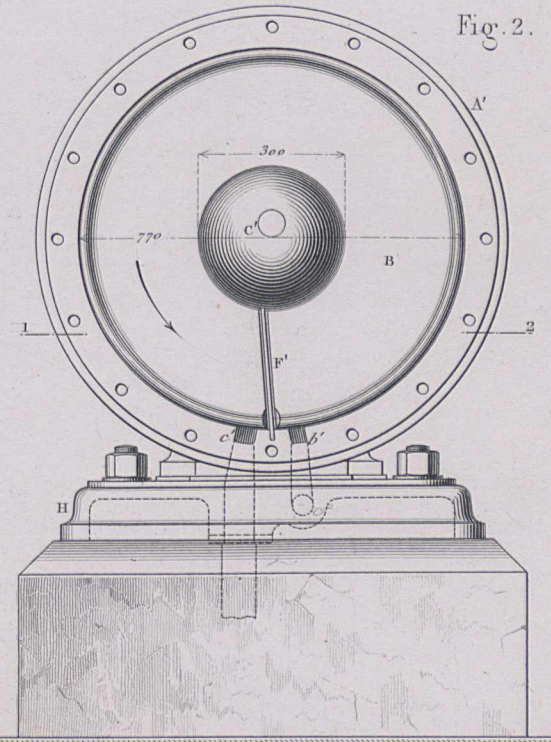

Fig. 4.

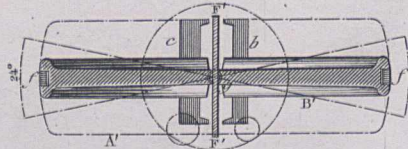

Fig. 5.

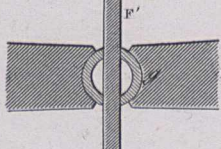
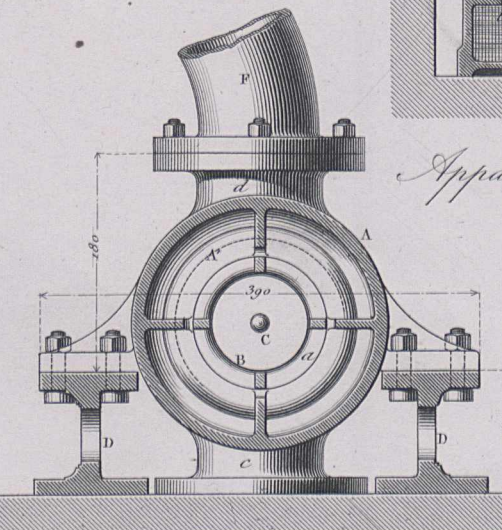
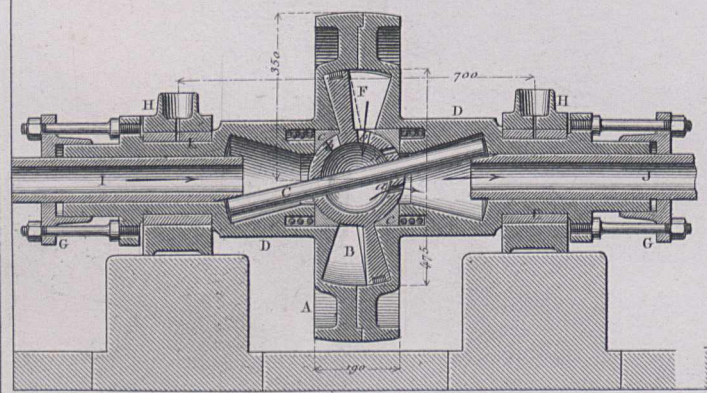

Fig. 8.



Machine à disque, à corps tournant.

Fig. 6.



*Appareil distributeur équilibré,
par M. Perret.*

Echelle de 1/6.

*Echelle de 1/15
pour les Fig. 4 à 6.*

Fig. 9.

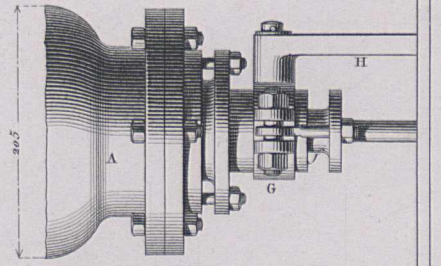
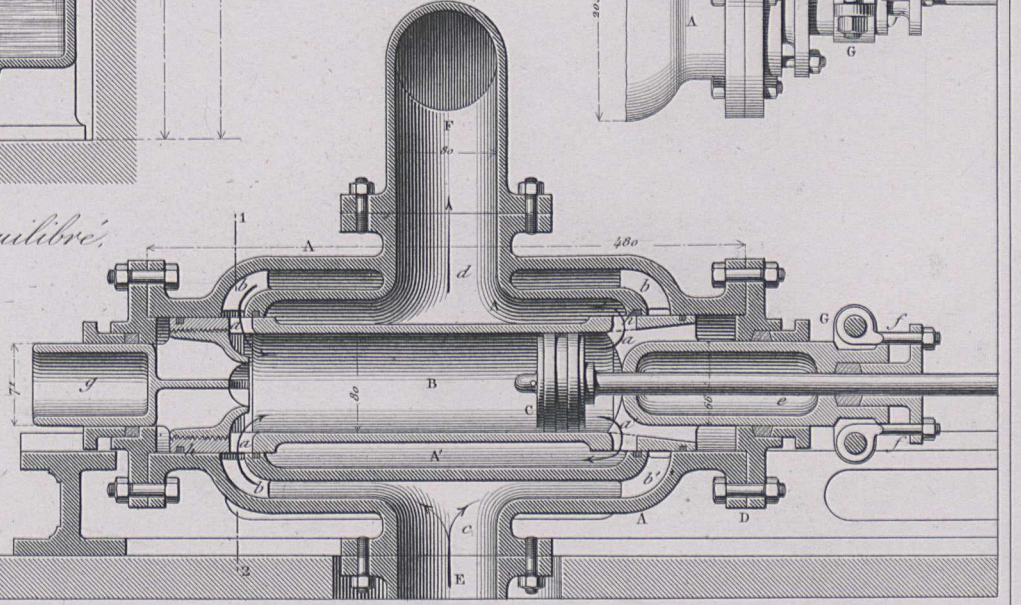
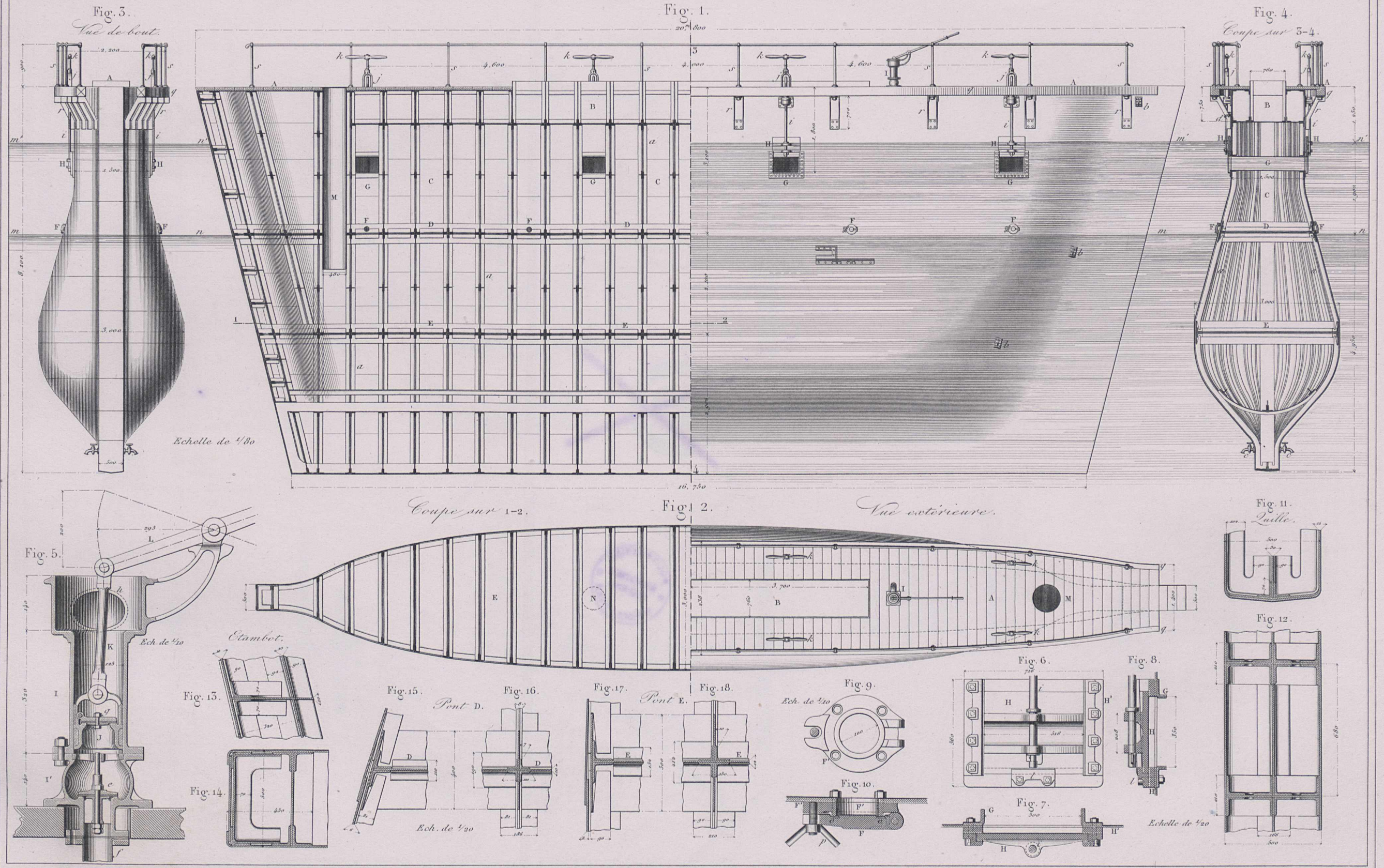

Fig. 7.









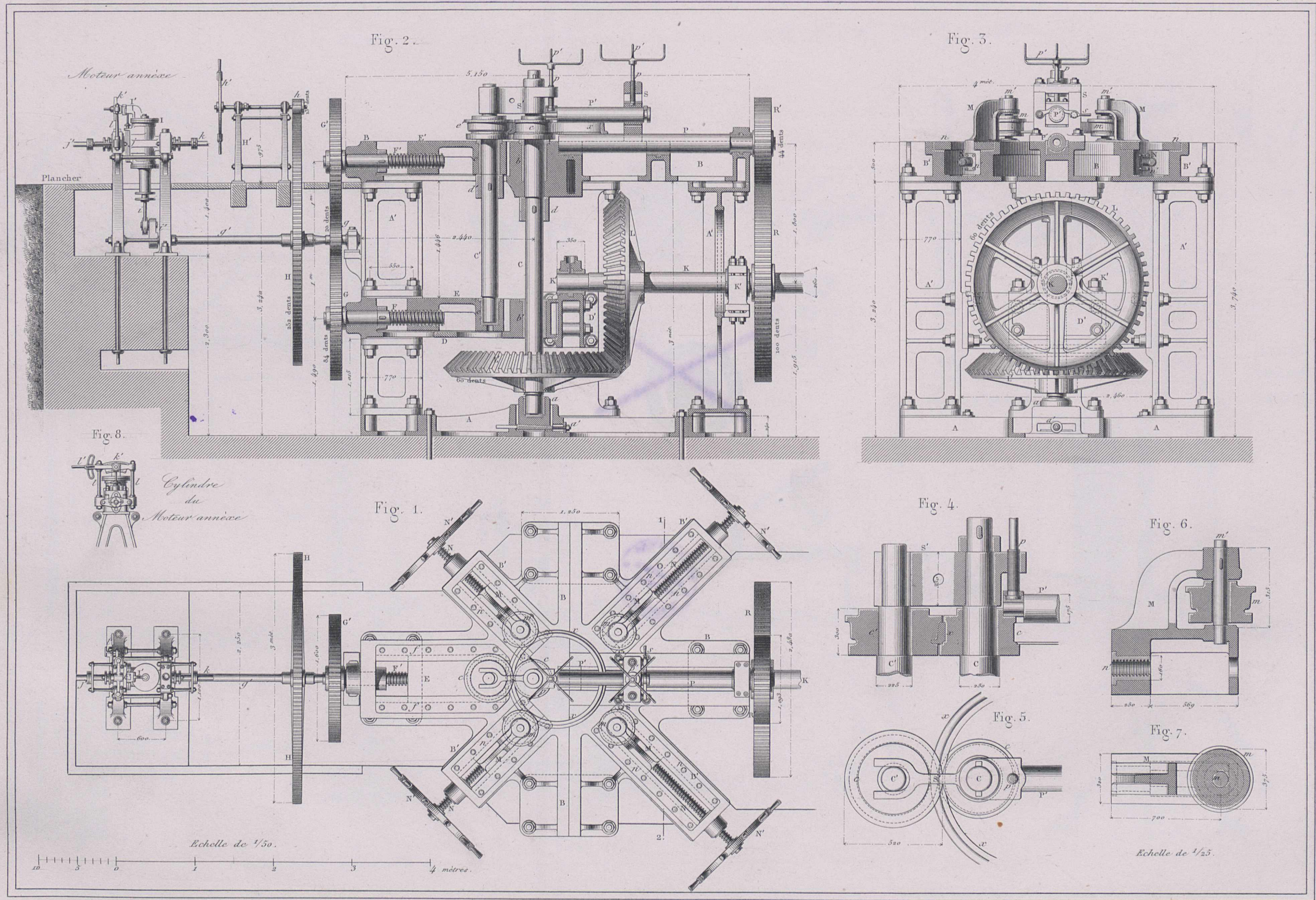



Modèle de M. Foucher, construit par M. M. F. Arbey et C^{ie}

Course maximum de l'outil: 0^m.300.

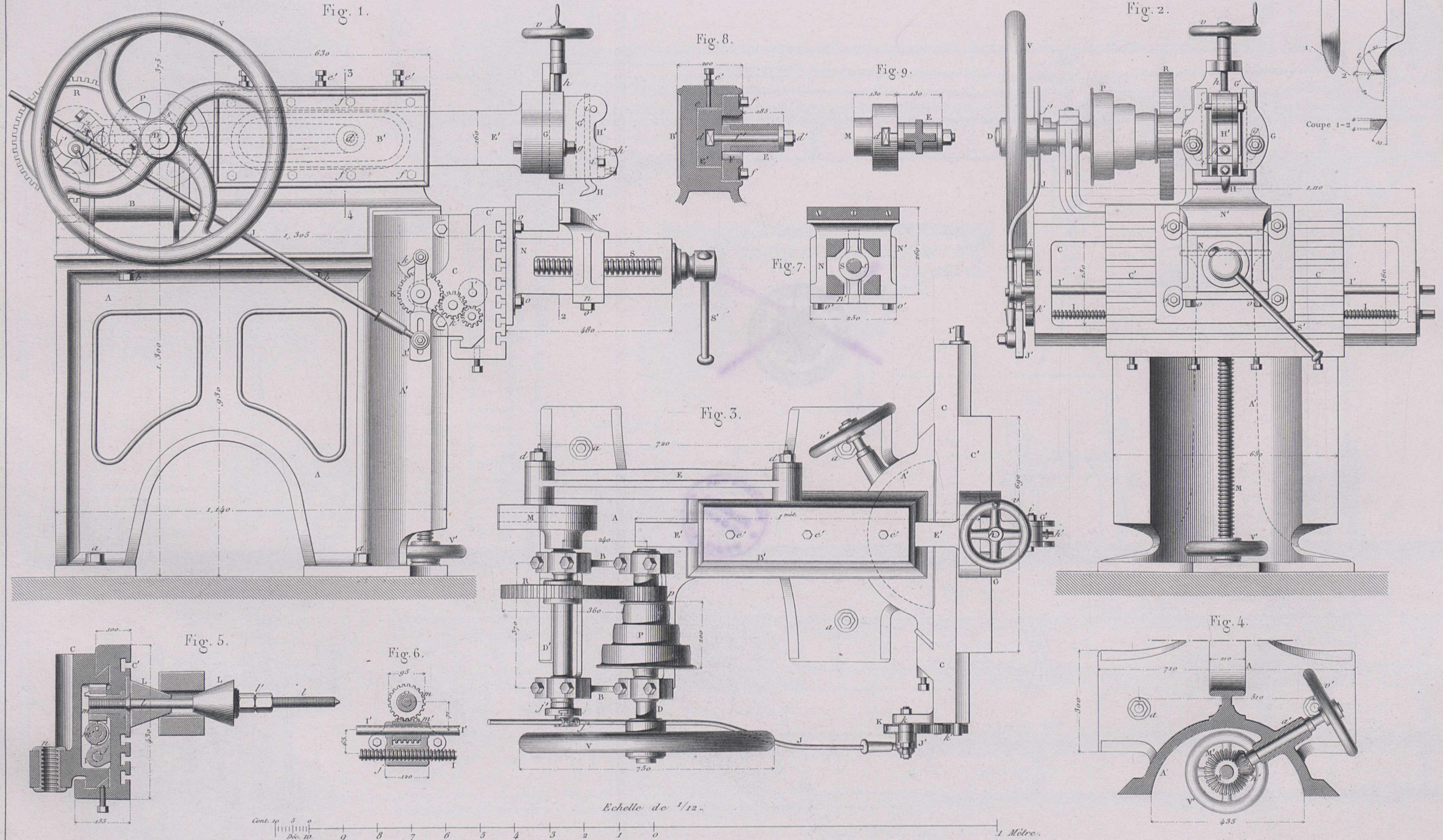



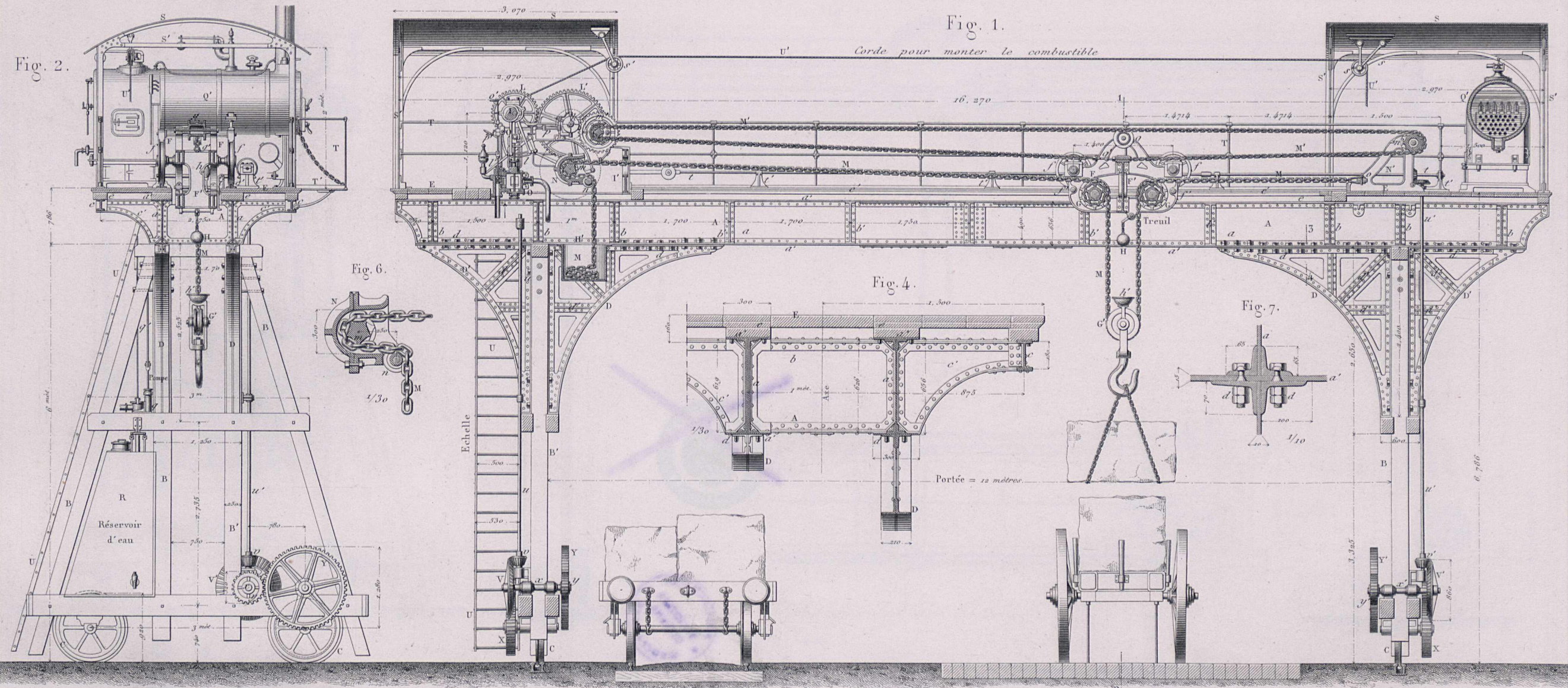

Fig. 2.

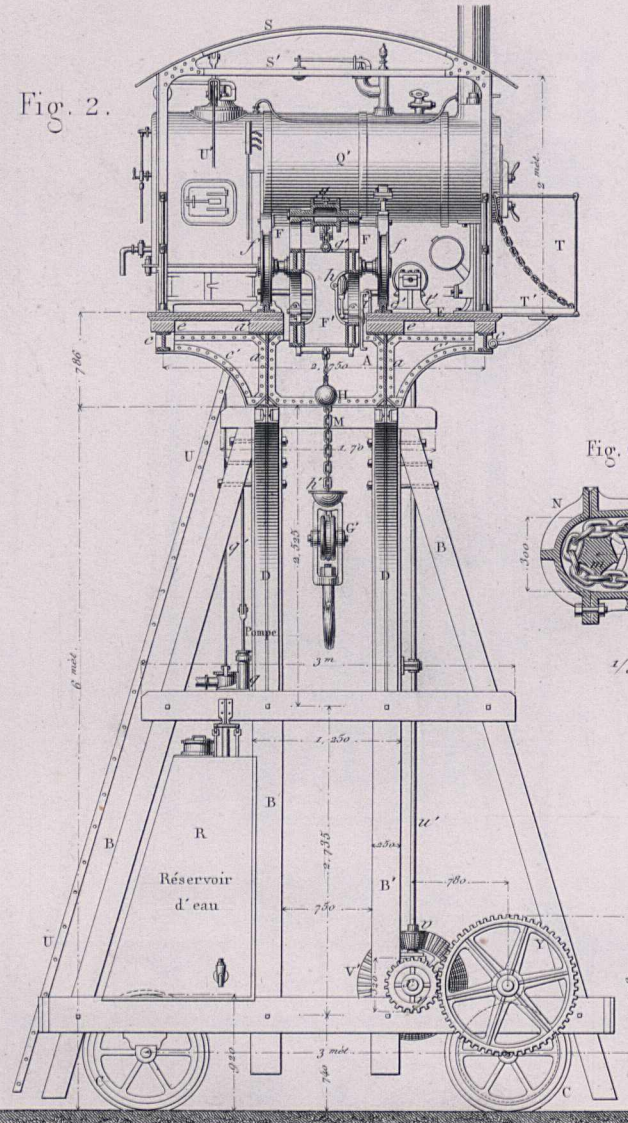

Fig. 6.

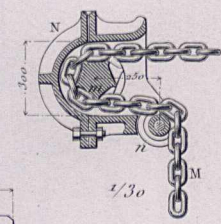

Fig. 4.

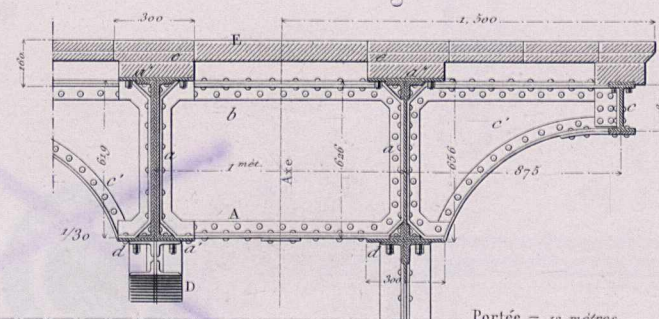
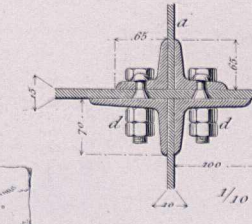

Fig. 7.



Machine motrice.

Fig. 5.

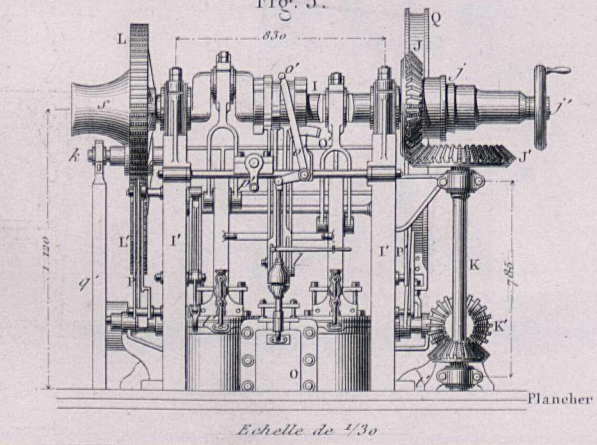
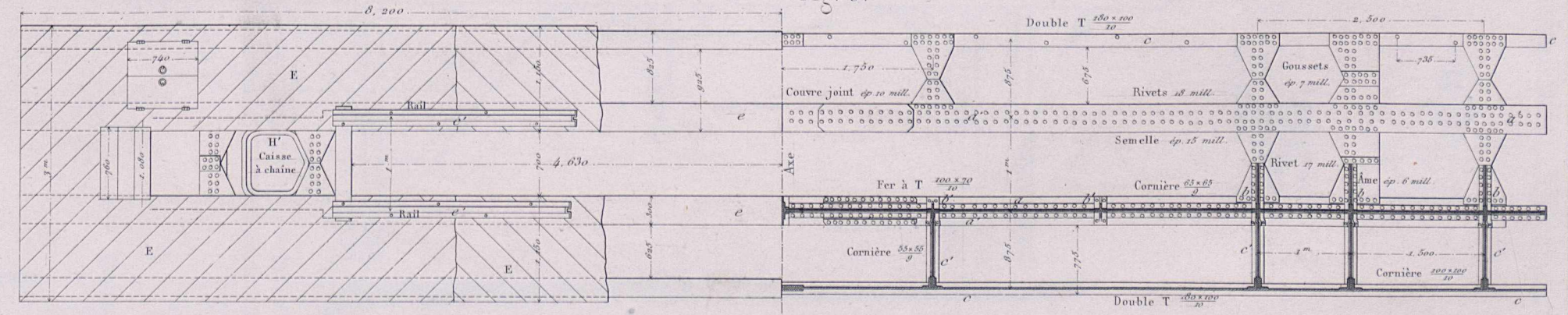
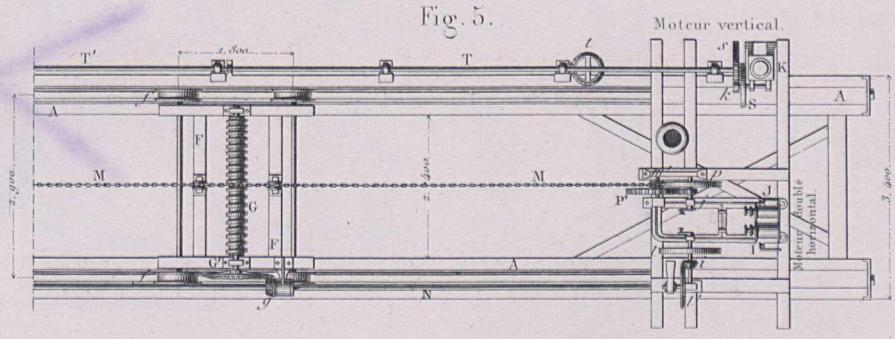
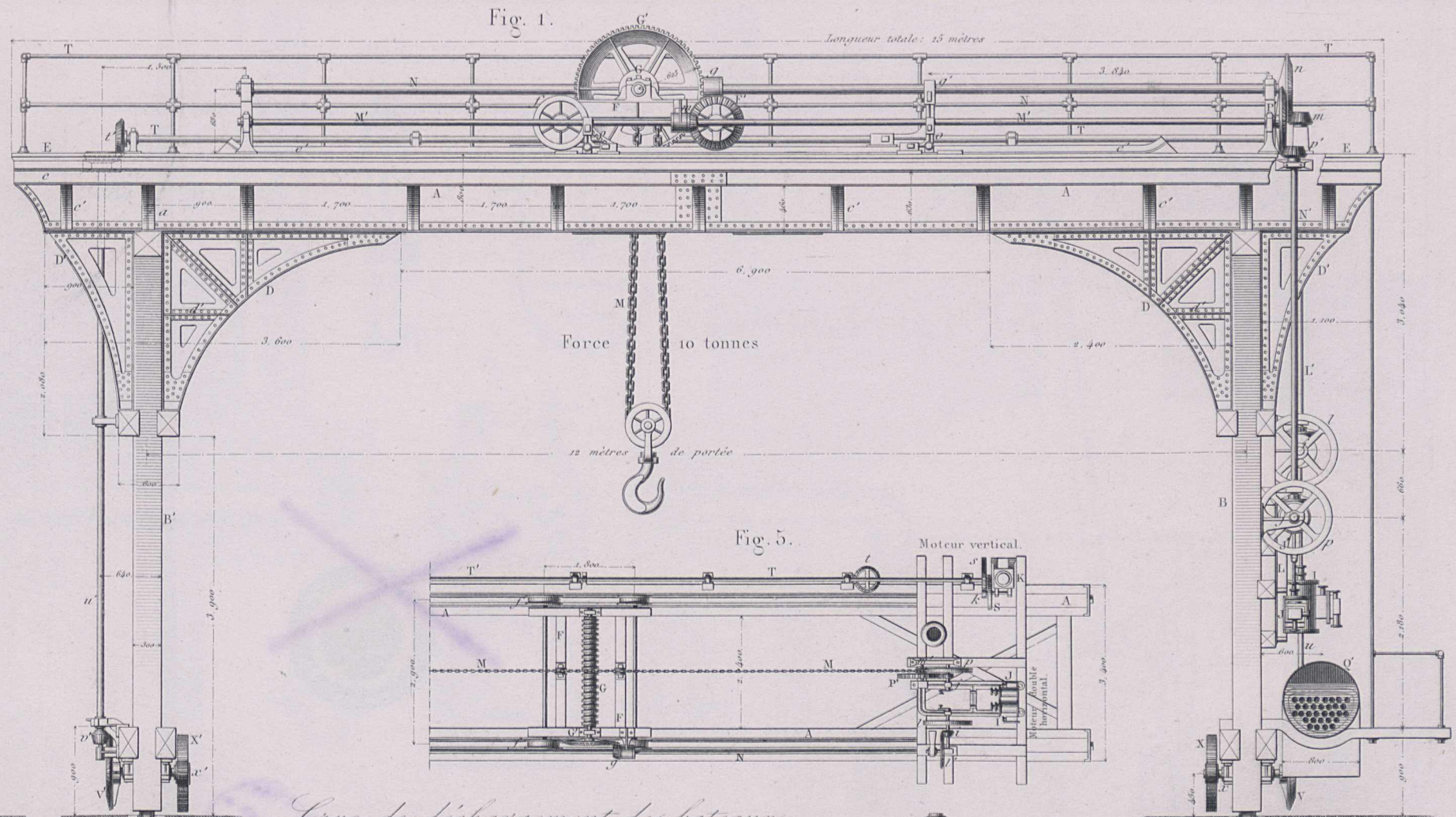
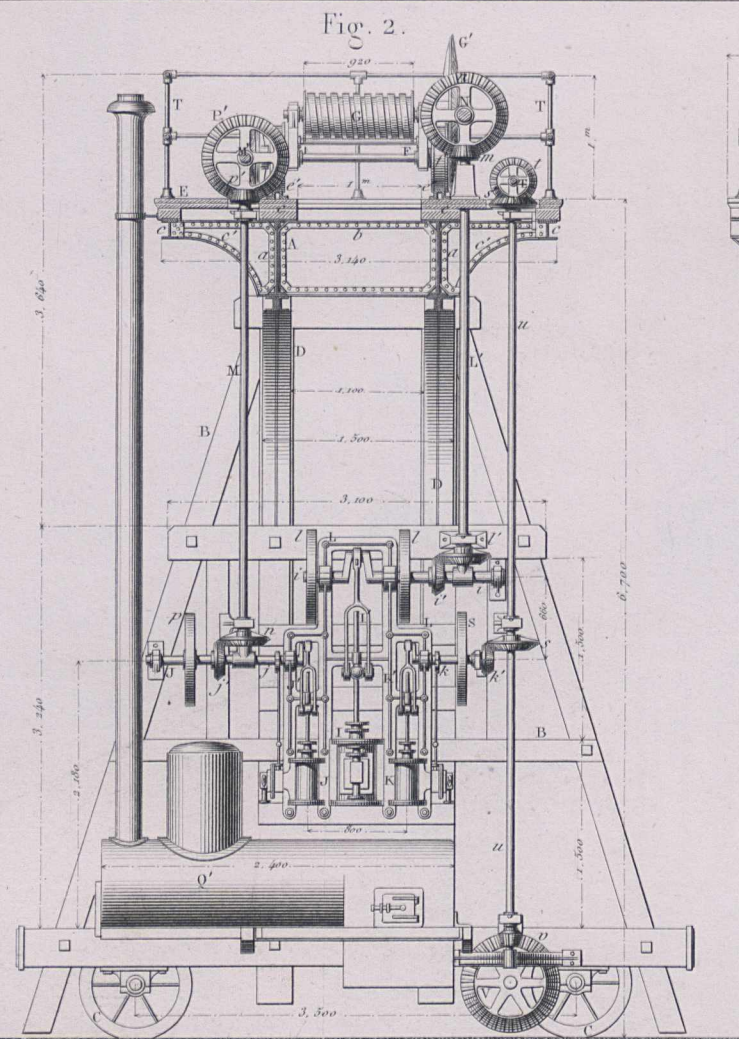

Fig. 3.



Echelle de 1/60 pour les Fig. 1 à 3.





Grue de déchargement des bateaux.

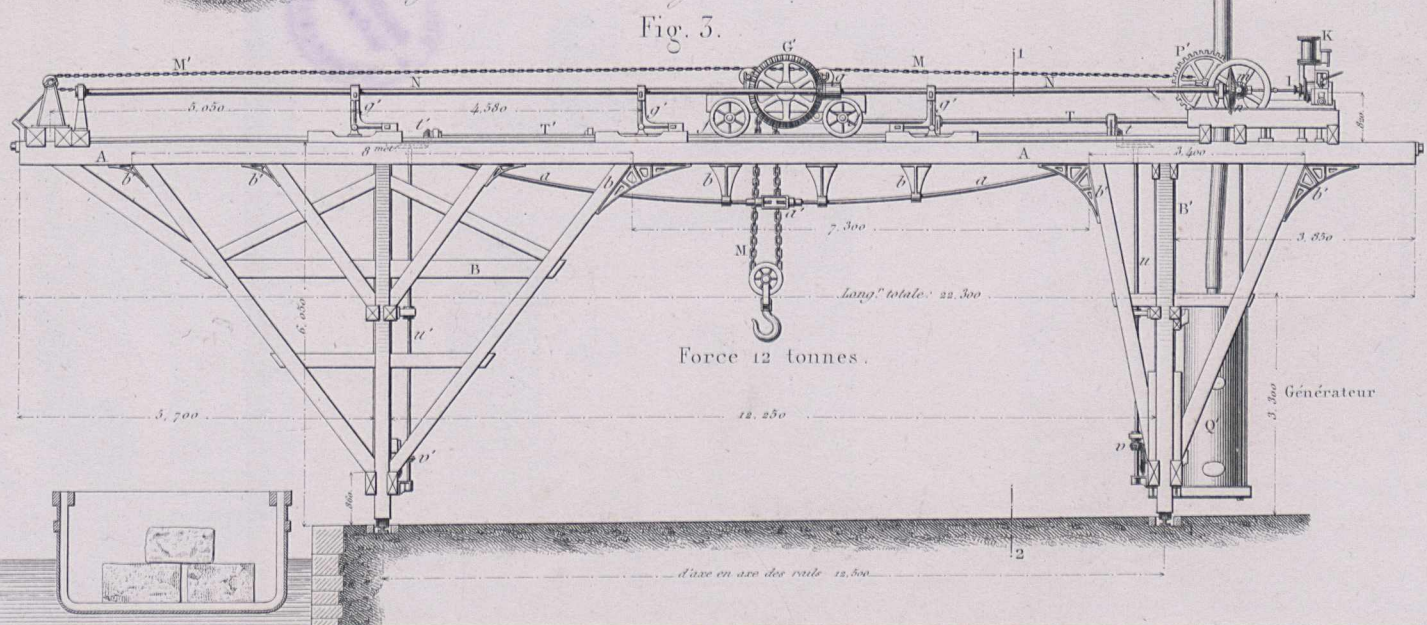
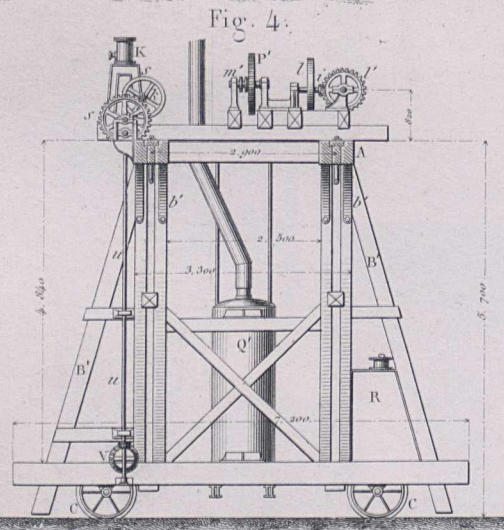

Mouvement de Translation.

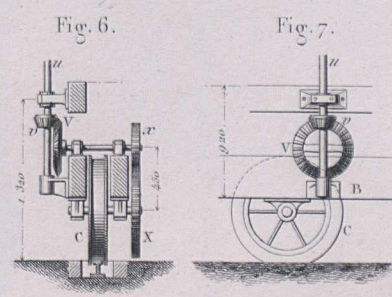

Echelle de 1/60 pour les Fig. 1, 2 et 6, 7.

Echelle de 1/120 pour les Fig. 3 et 4.



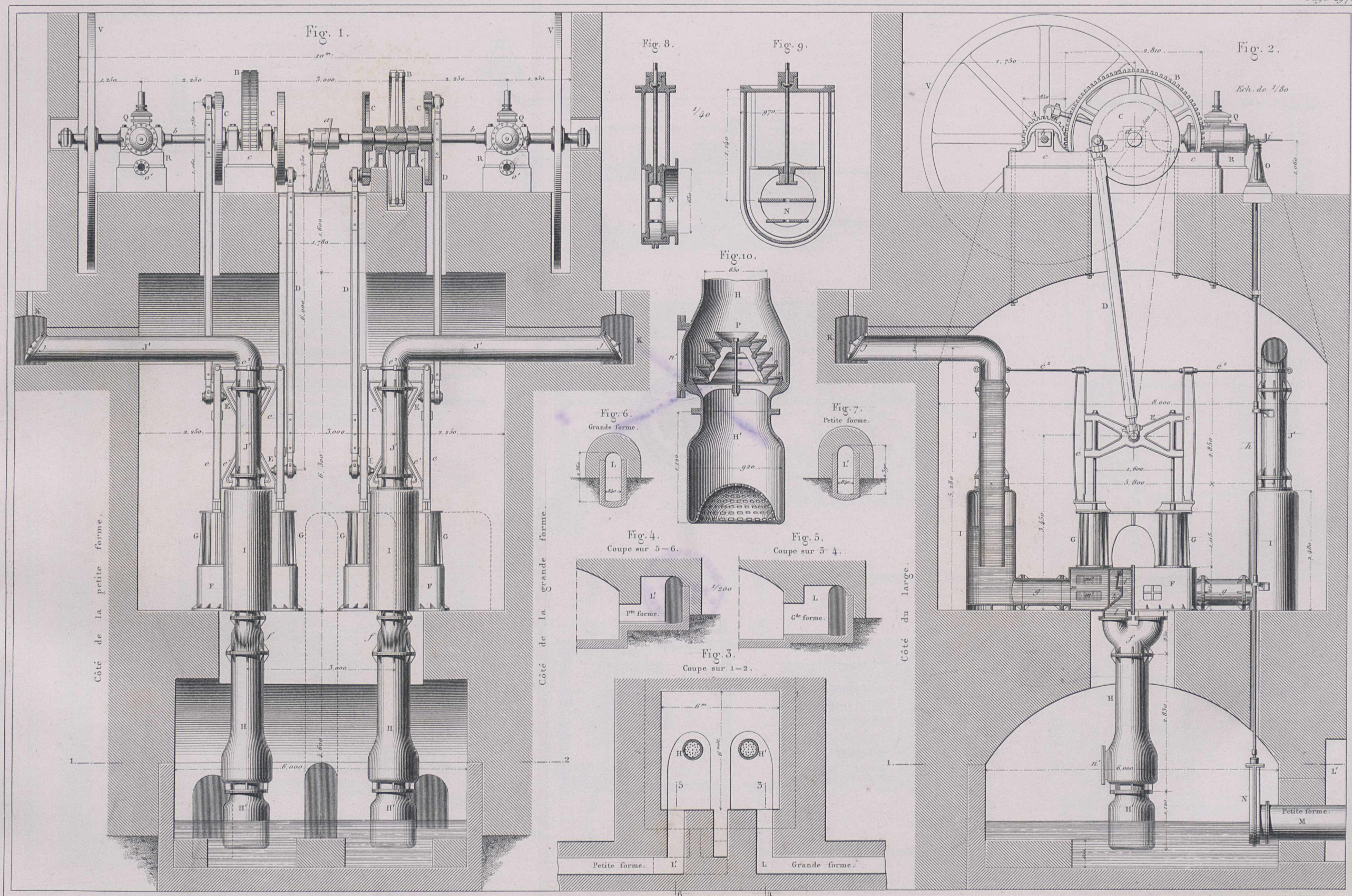



Machines motrices.

Fig. 15.

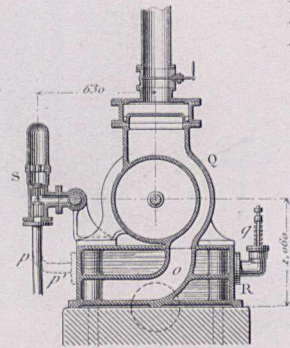

Diamètre des cylindres 0,45.
 Course des pistons 1 mètr.
 Nombre de tours par 1' 50.
 Durée de la détente $\frac{1}{3}$ de la course.
 Pression absolue de la vapeur 5 atmosphères.

Fig. 14.

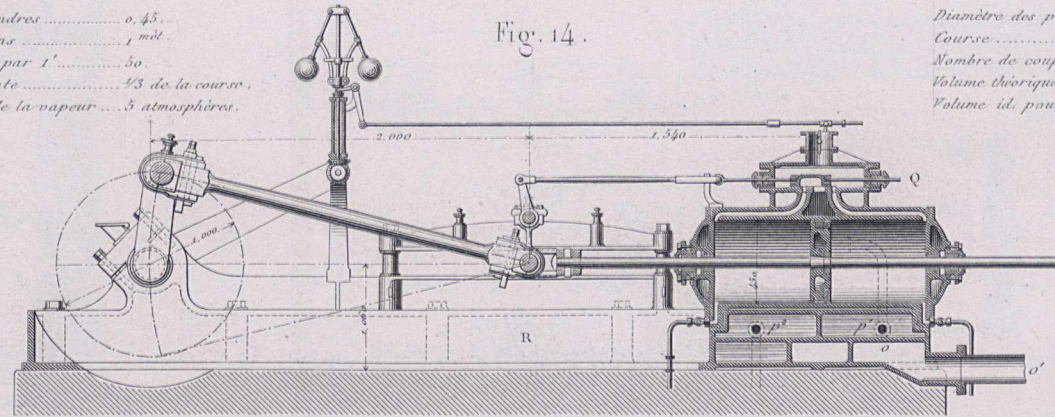

Pompes.

Fig. 16.

Diamètre des pistons 0^m.50.
 Course 1,50.
 Nombre de coups doubles par 1' 24 à 15.
 Volume théorique engendré par coup simple 0^m.c. 294 450.
 Volume id. pour les huit coups 2^m.c. 355.

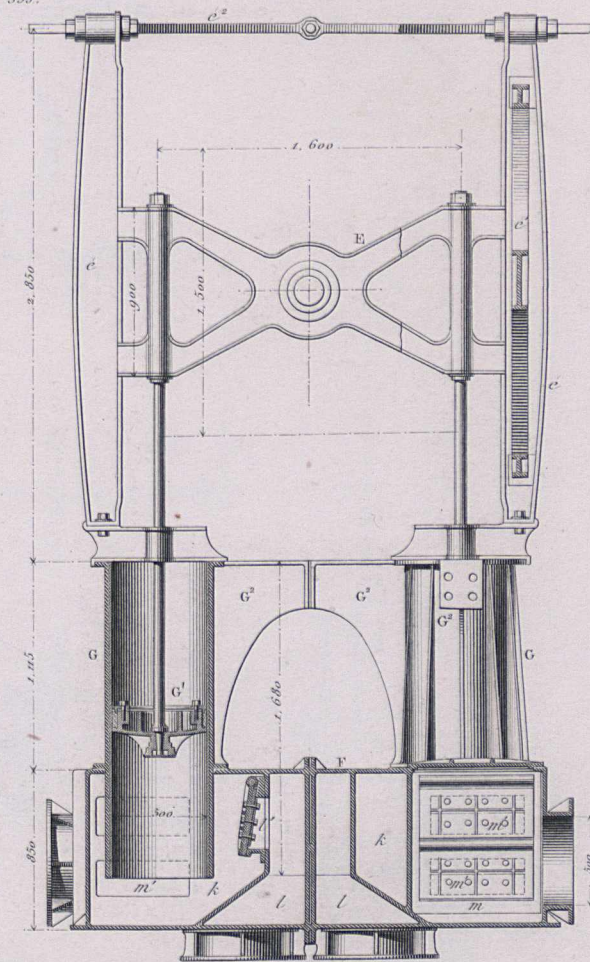

Echelle de $\frac{1}{40}$ p^r Fig. 14 à 17.

Fig. 11.

Côté de la grande forme.

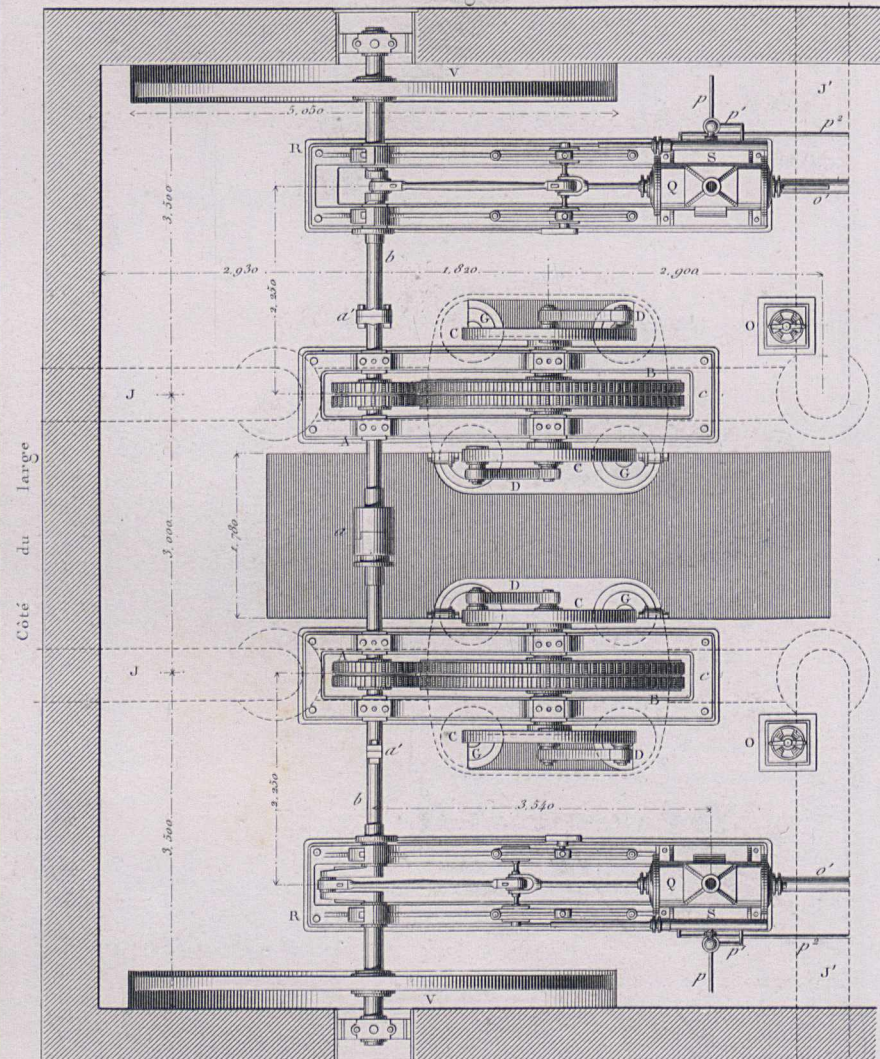

Côté de la petite forme.

Fig. 12.

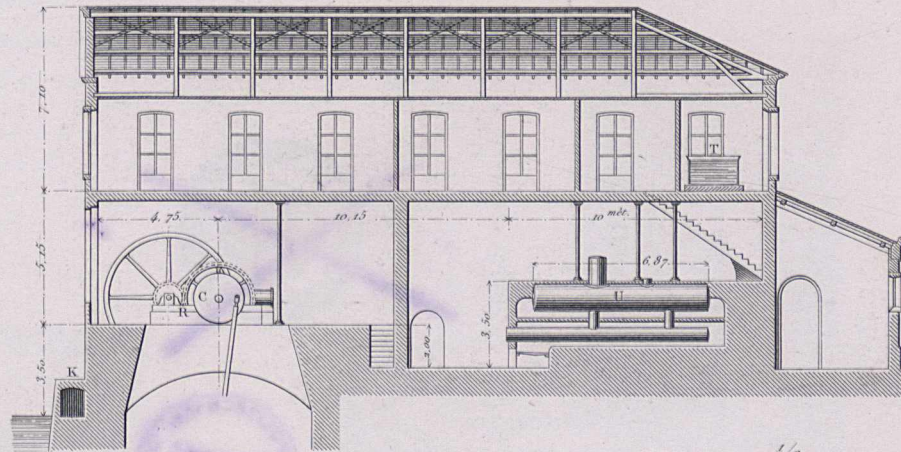

Fig. 13.

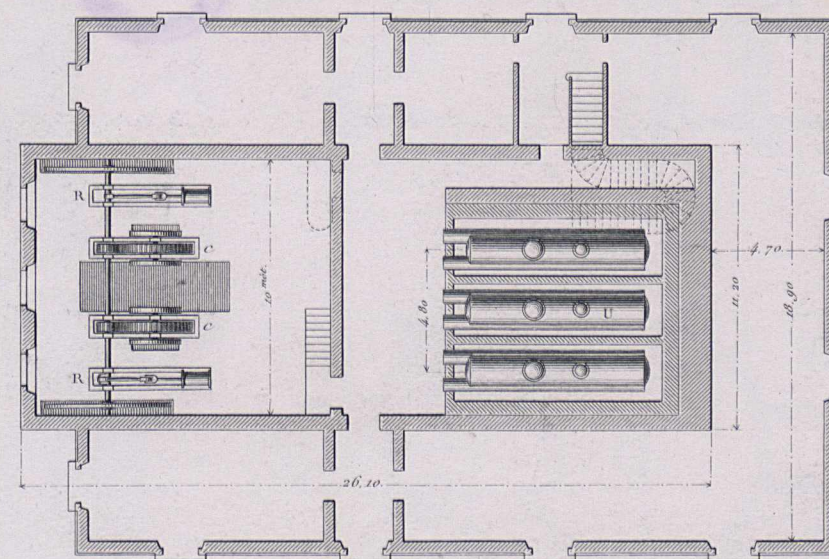
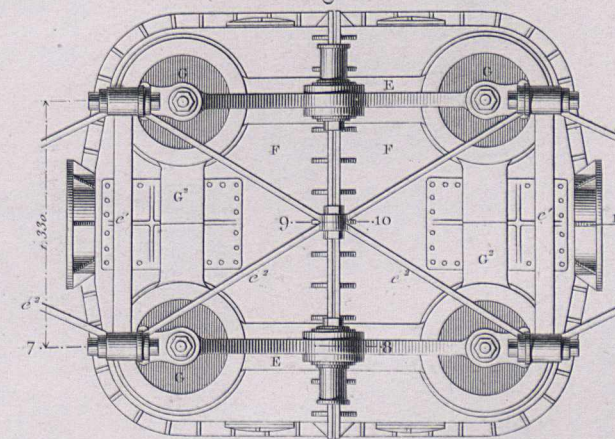
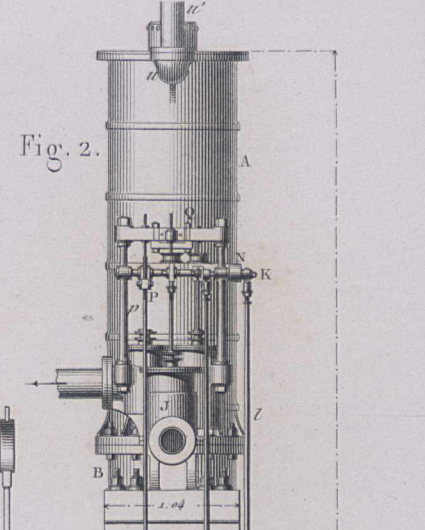
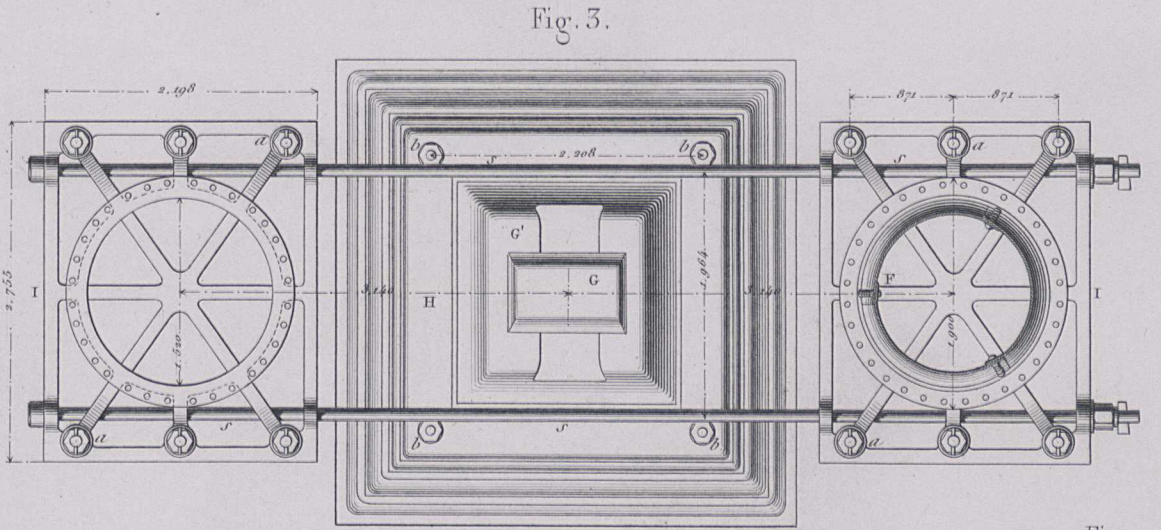
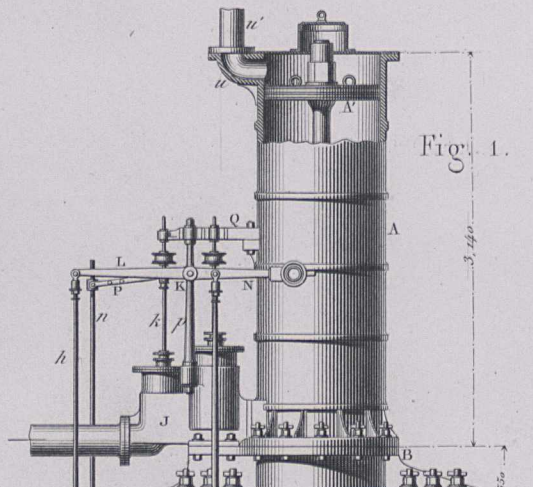
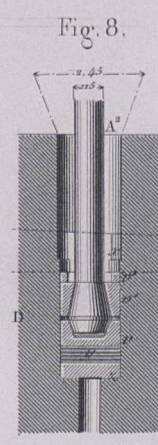

Fig. 17.







Echelle de 1/60 pour les Fig. 1 à 3.
Echelle de 1/30 pour les Fig. 4 à 8.

Poids du marteau..... 15, 190^{kil.}
Hauteur de la chute..... 2^m 510.
Poids total..... 230, 940^{kil.}

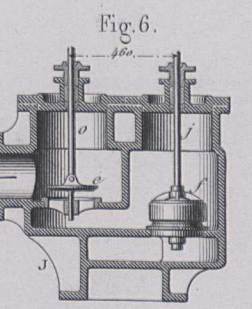
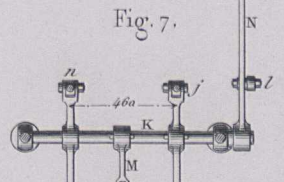
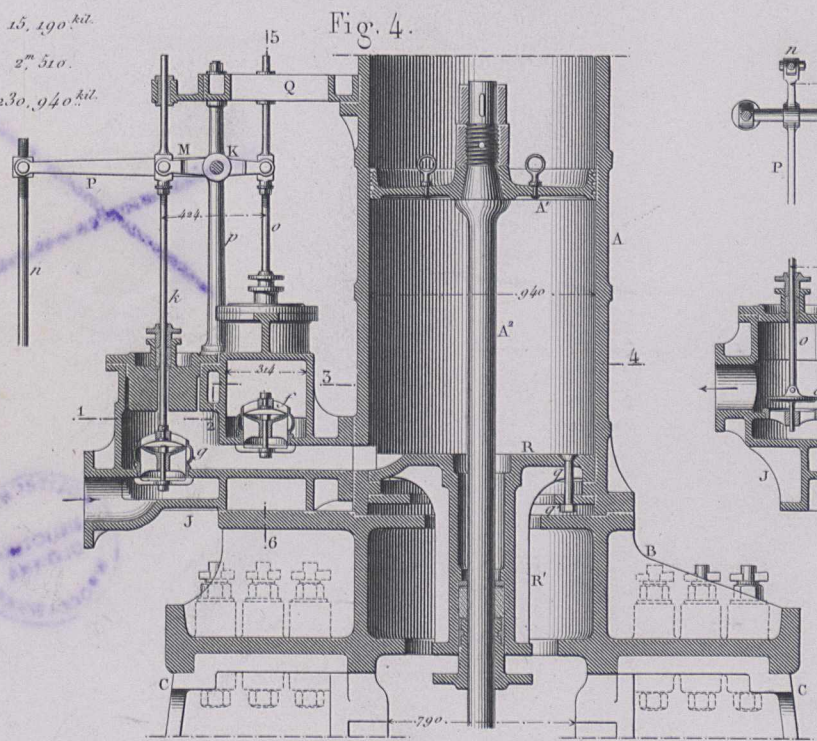
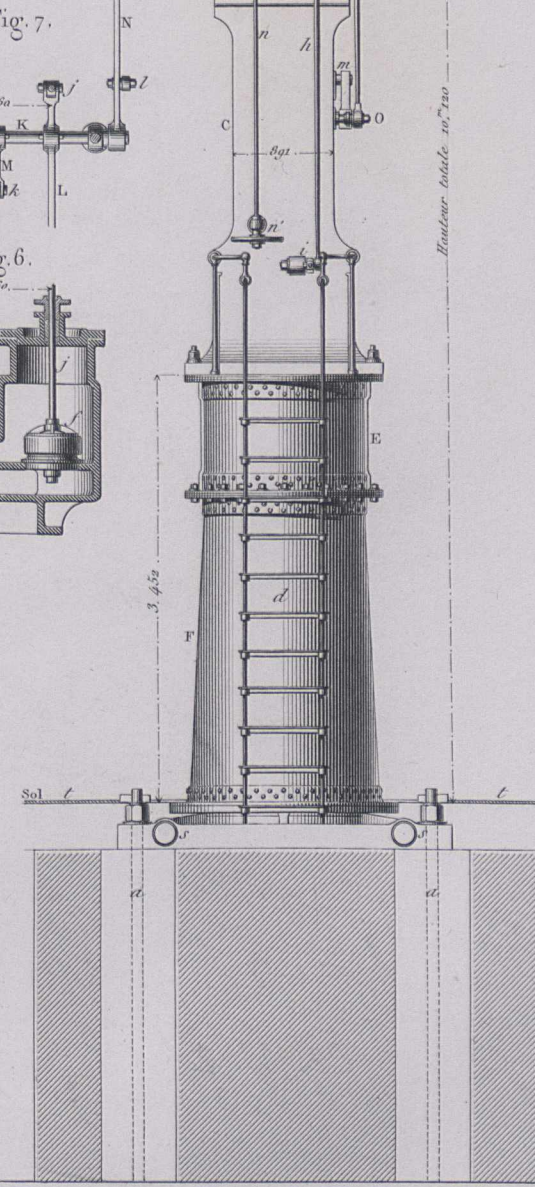
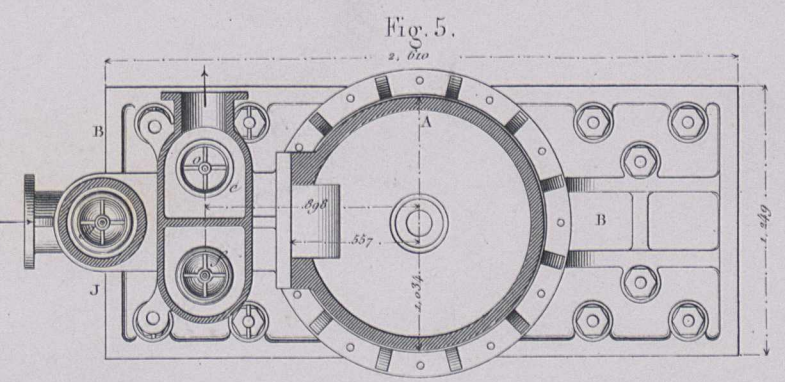
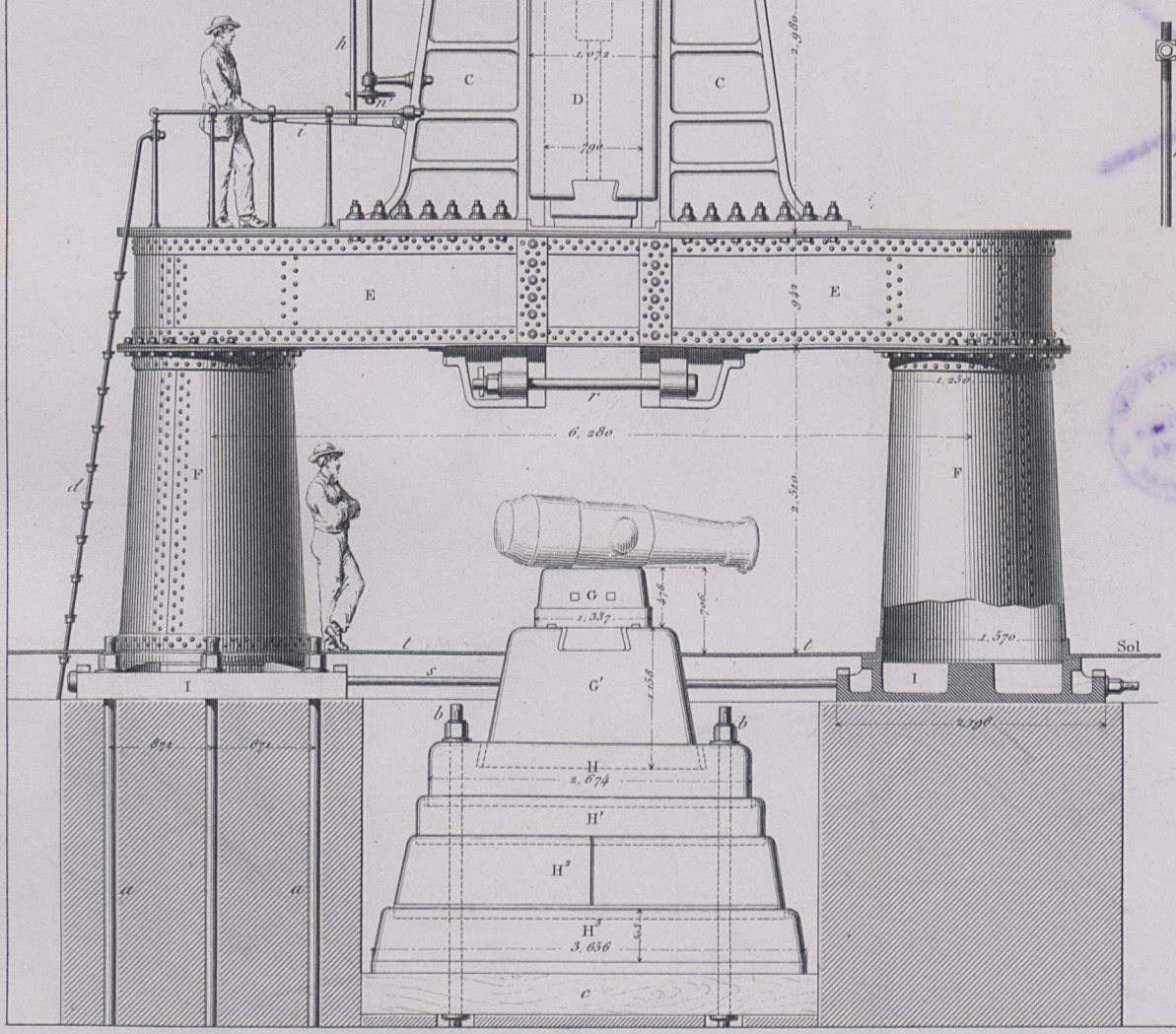
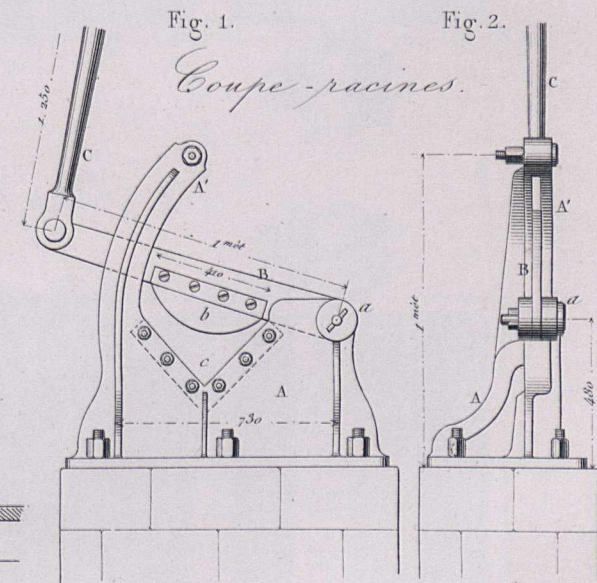
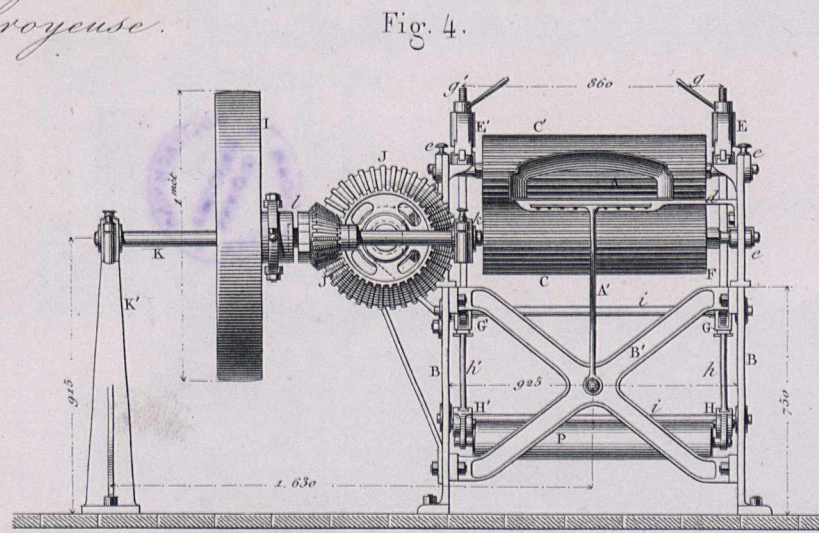
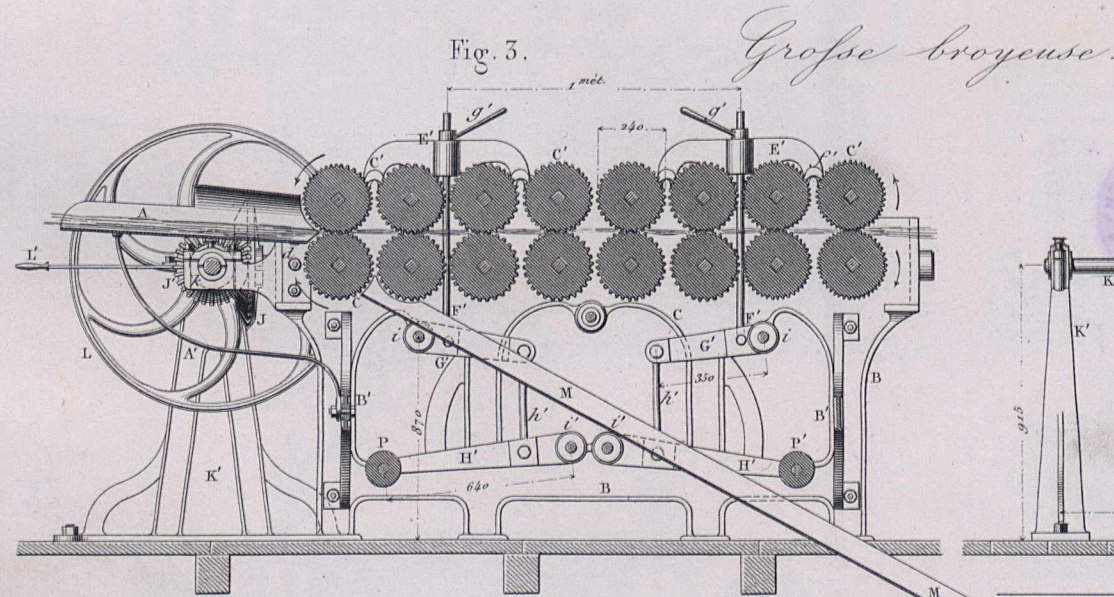
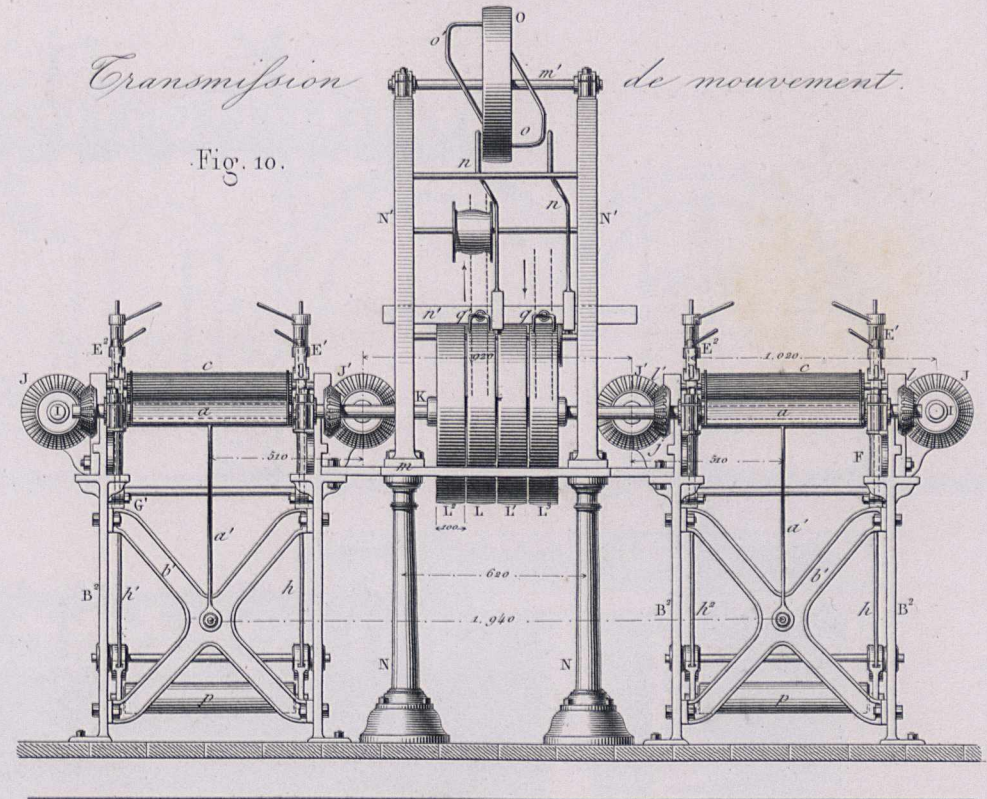
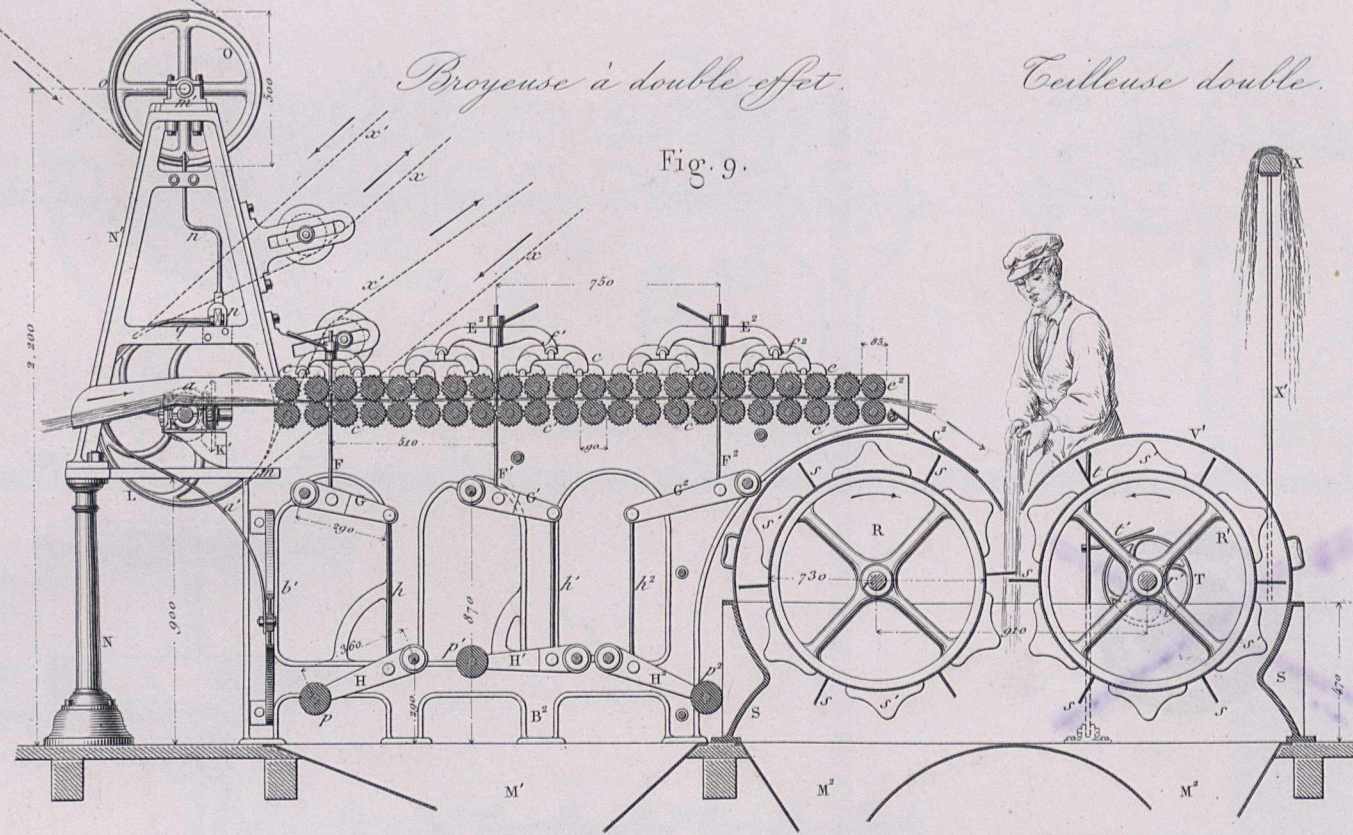

Fig. 7.

Fig. 6.







Echelle de $\frac{1}{25}$.
0 1 2 3 4 5 6 7 8 9 10 Mètres.



Fig. 5.

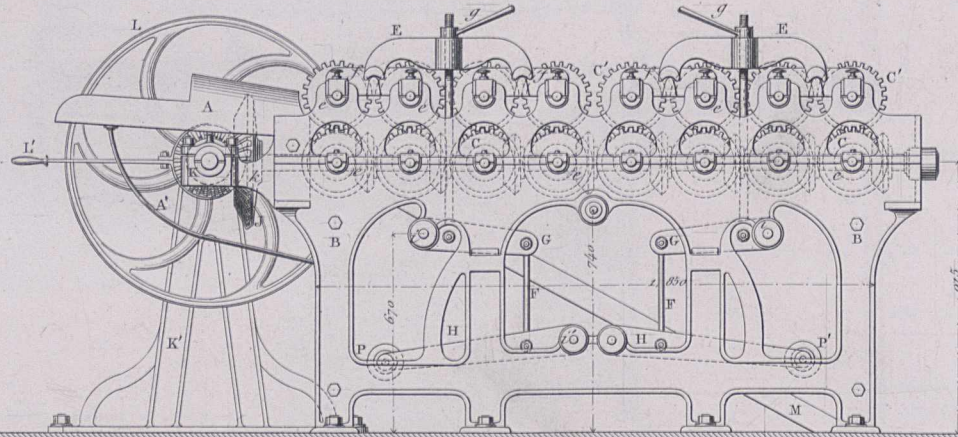

Fig. 8.

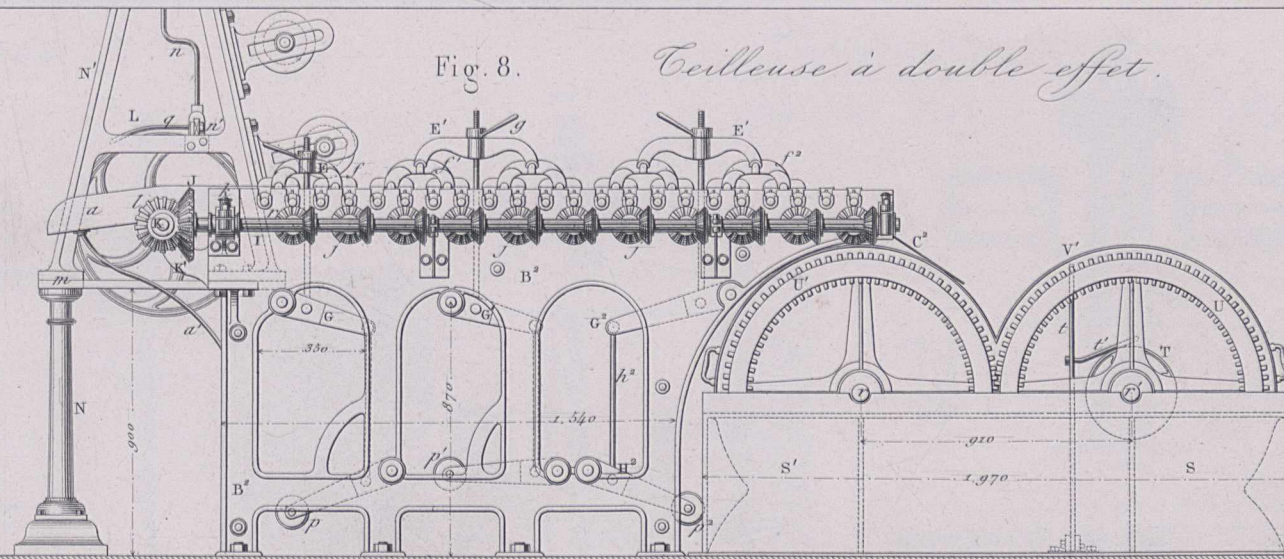

Fig. 6.

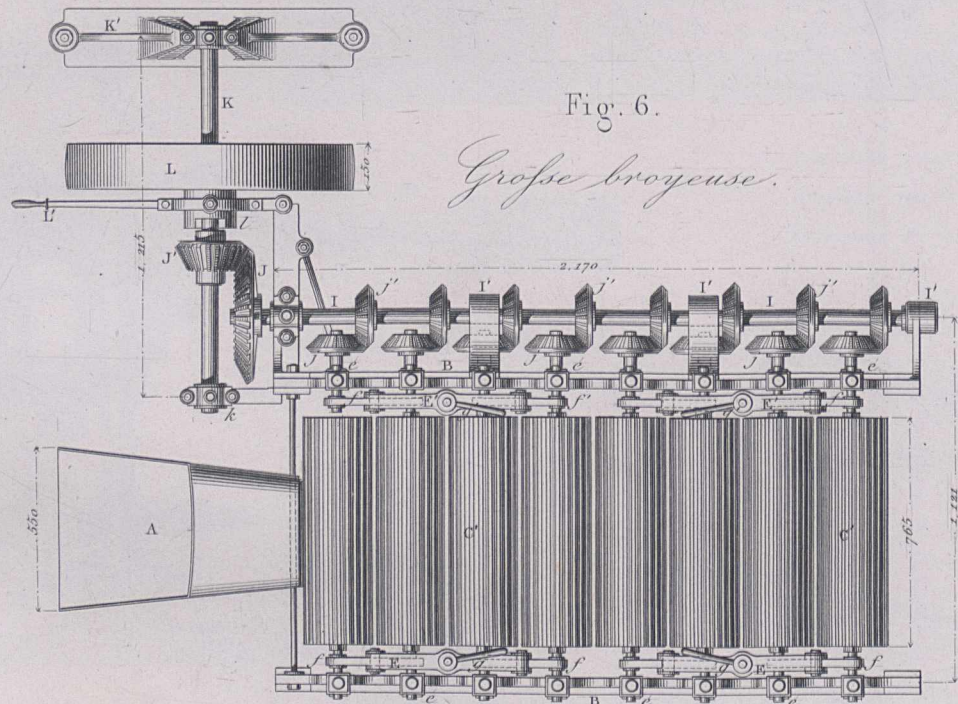

Fig. 7.

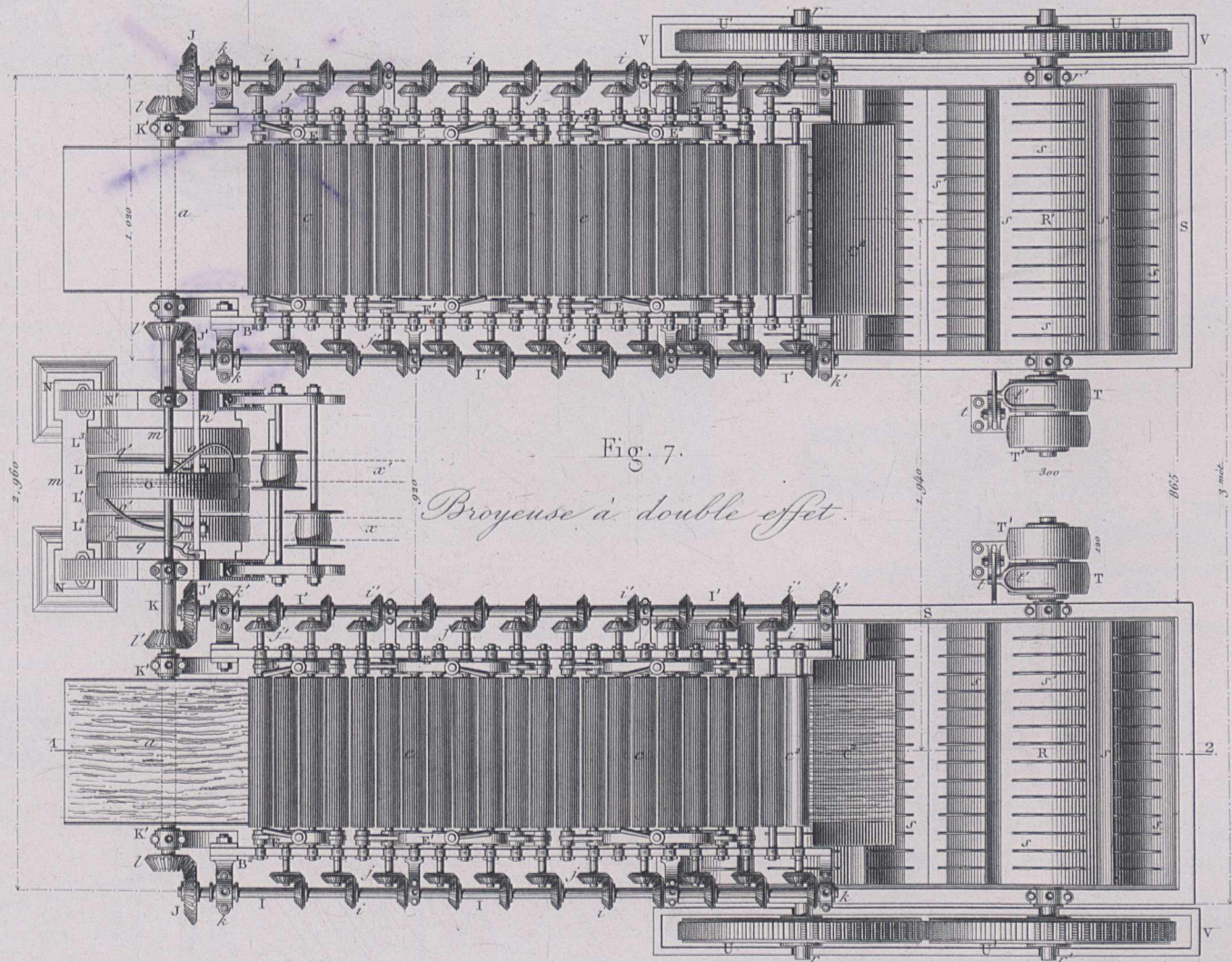
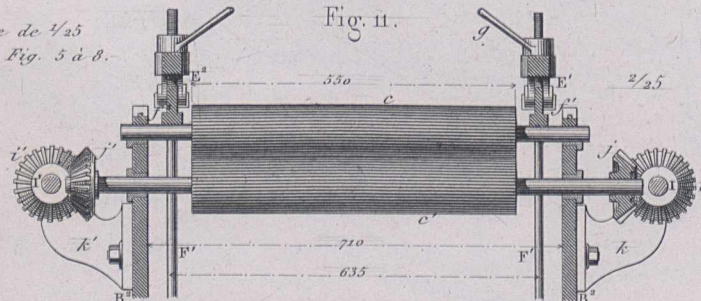

Fig. 11.

Echelle de 1/25 pour les Fig. 5 à 8.





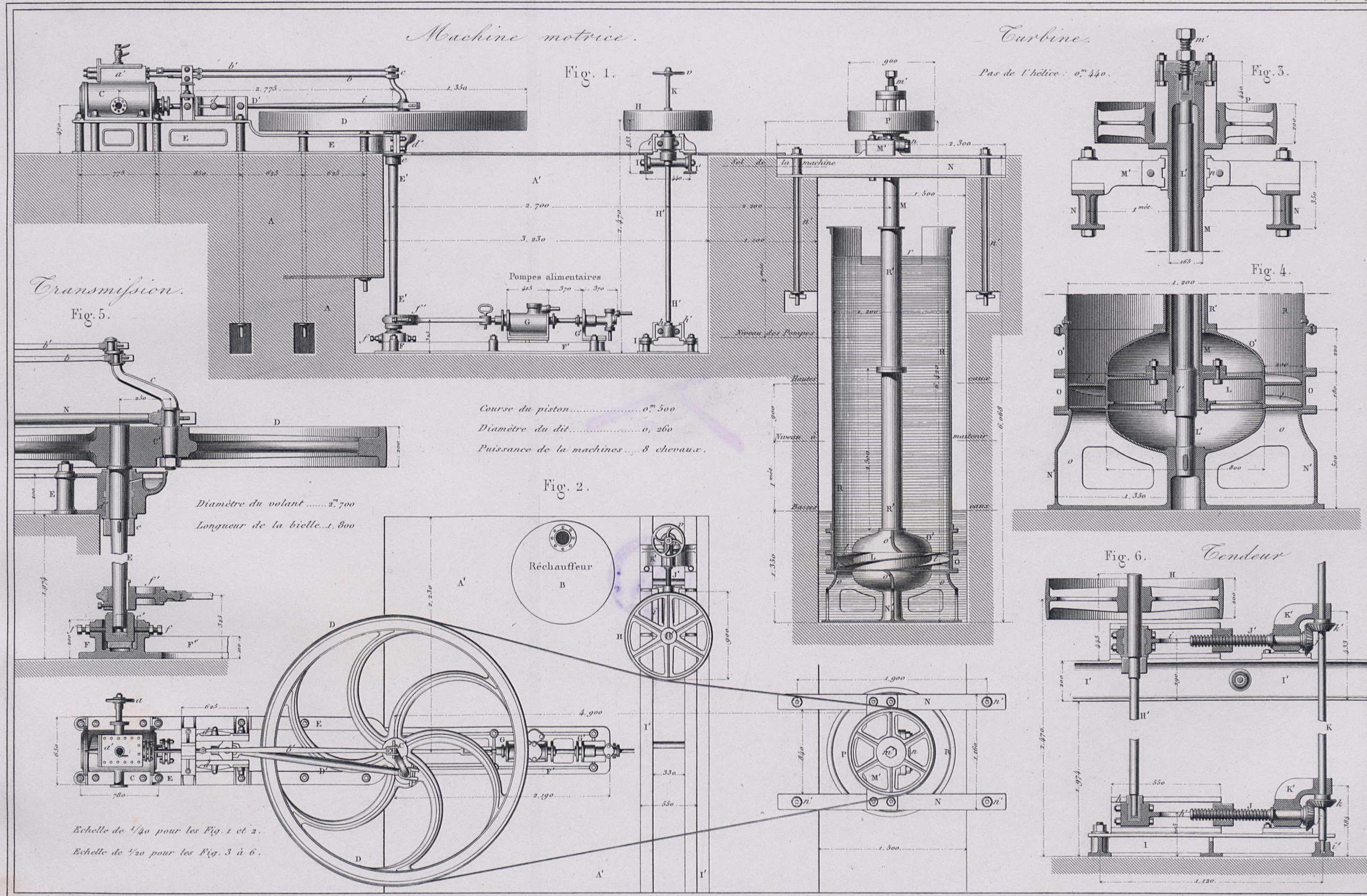



Fig. 1.

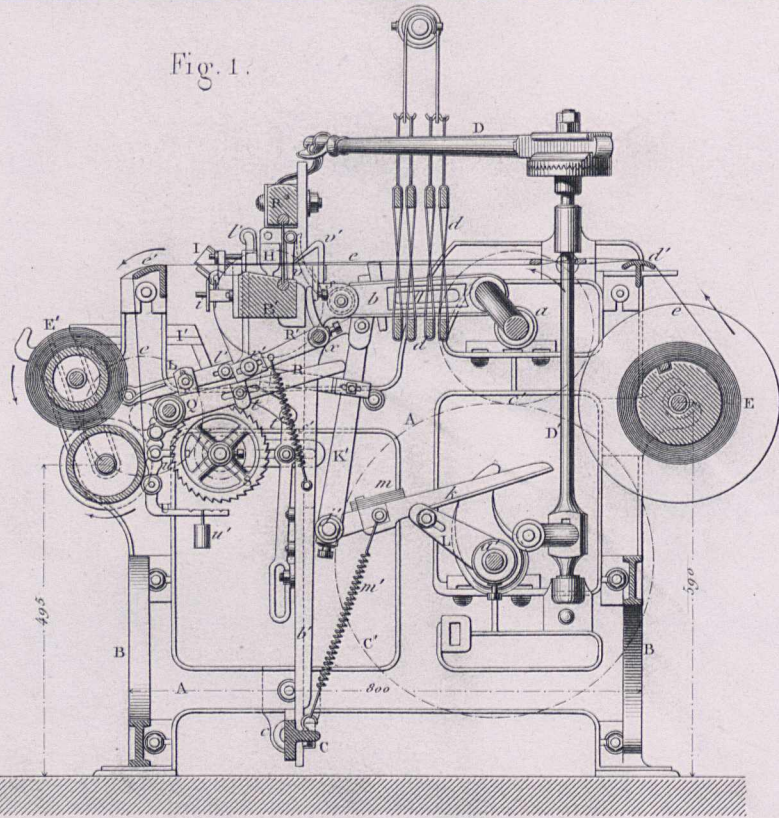

Fig. 2.

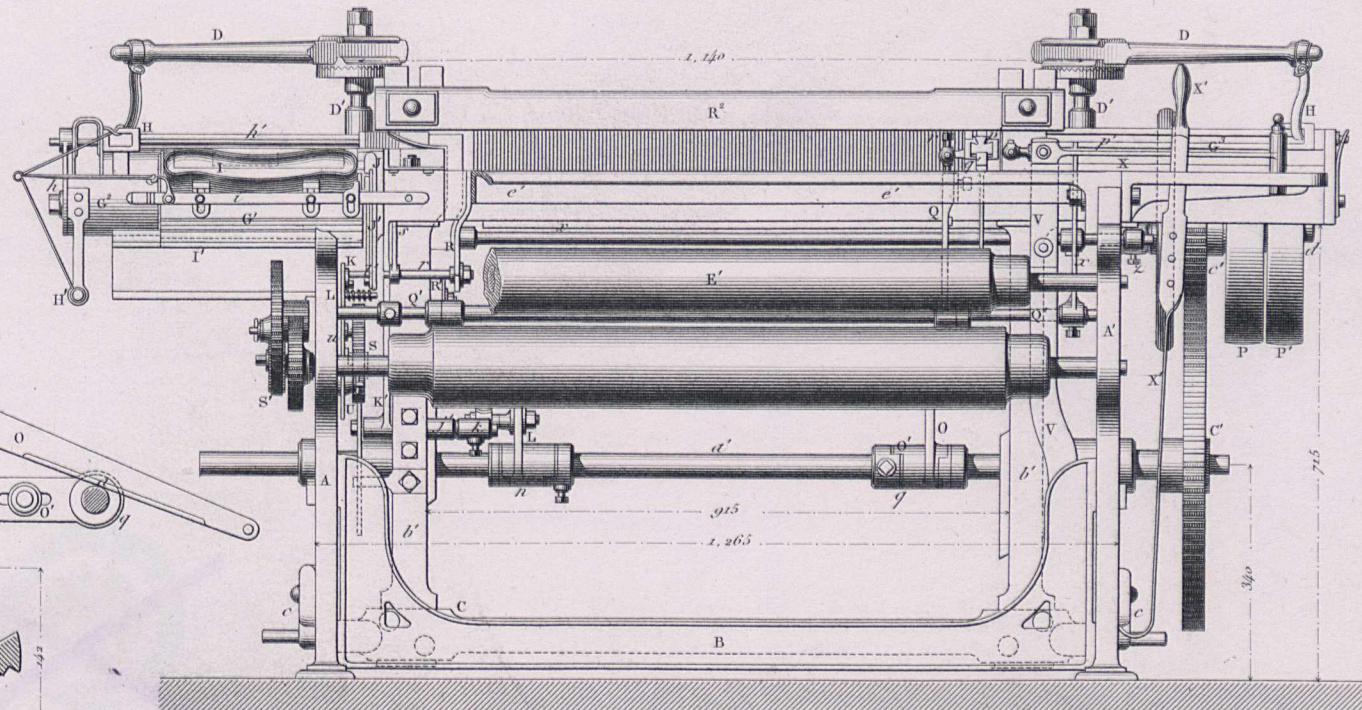

Fig. 11.

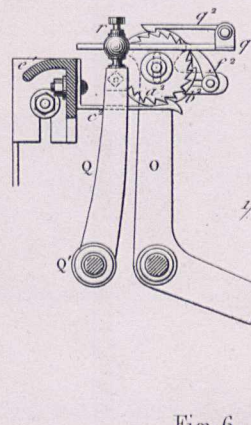

Fig. 6.

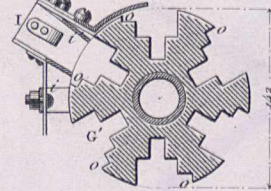

Fig. 4.

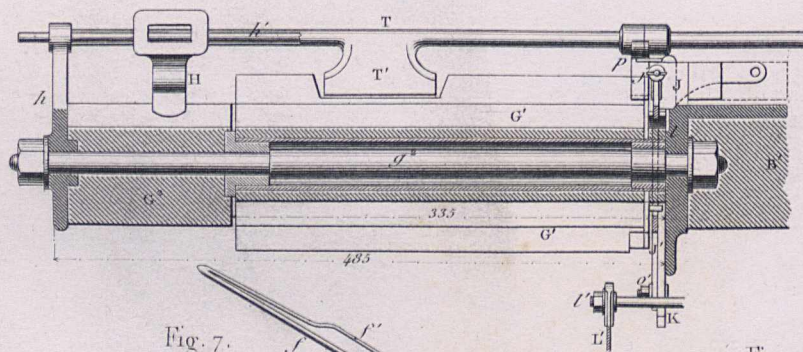

Fig. 5.

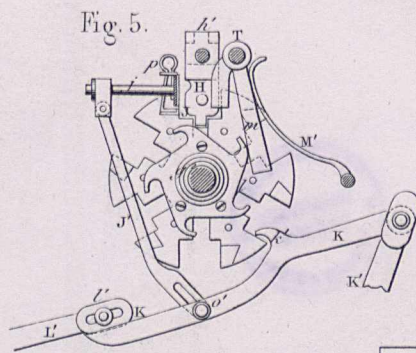

Fig. 3.

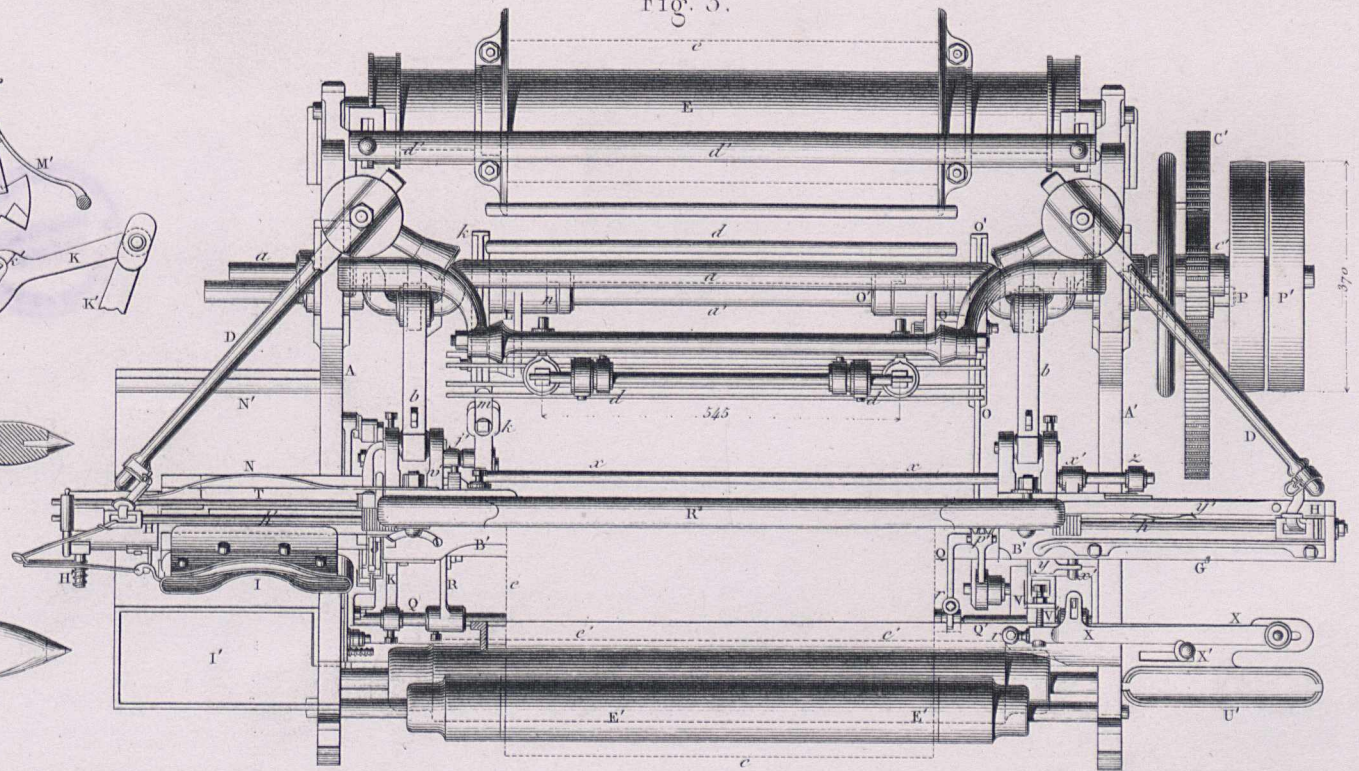

Fig. 7.

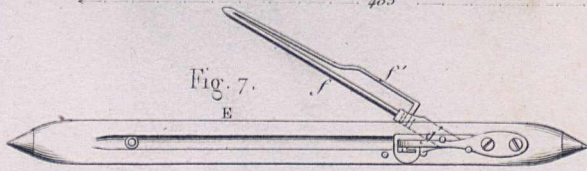

Fig. 9.

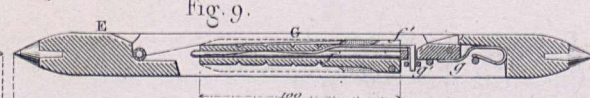

Fig. 8.

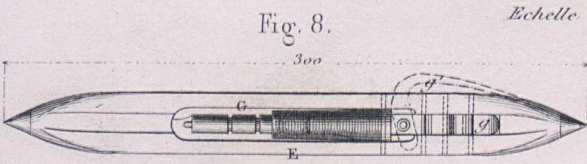
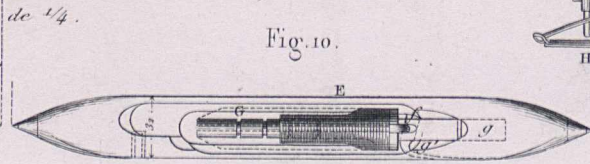

Fig. 10.



Echelle de 1/12 pour les Fig. 1 à 3.

Echelle de 1/6 pour les Fig. 4 à 6.

Echelle de 1/4.



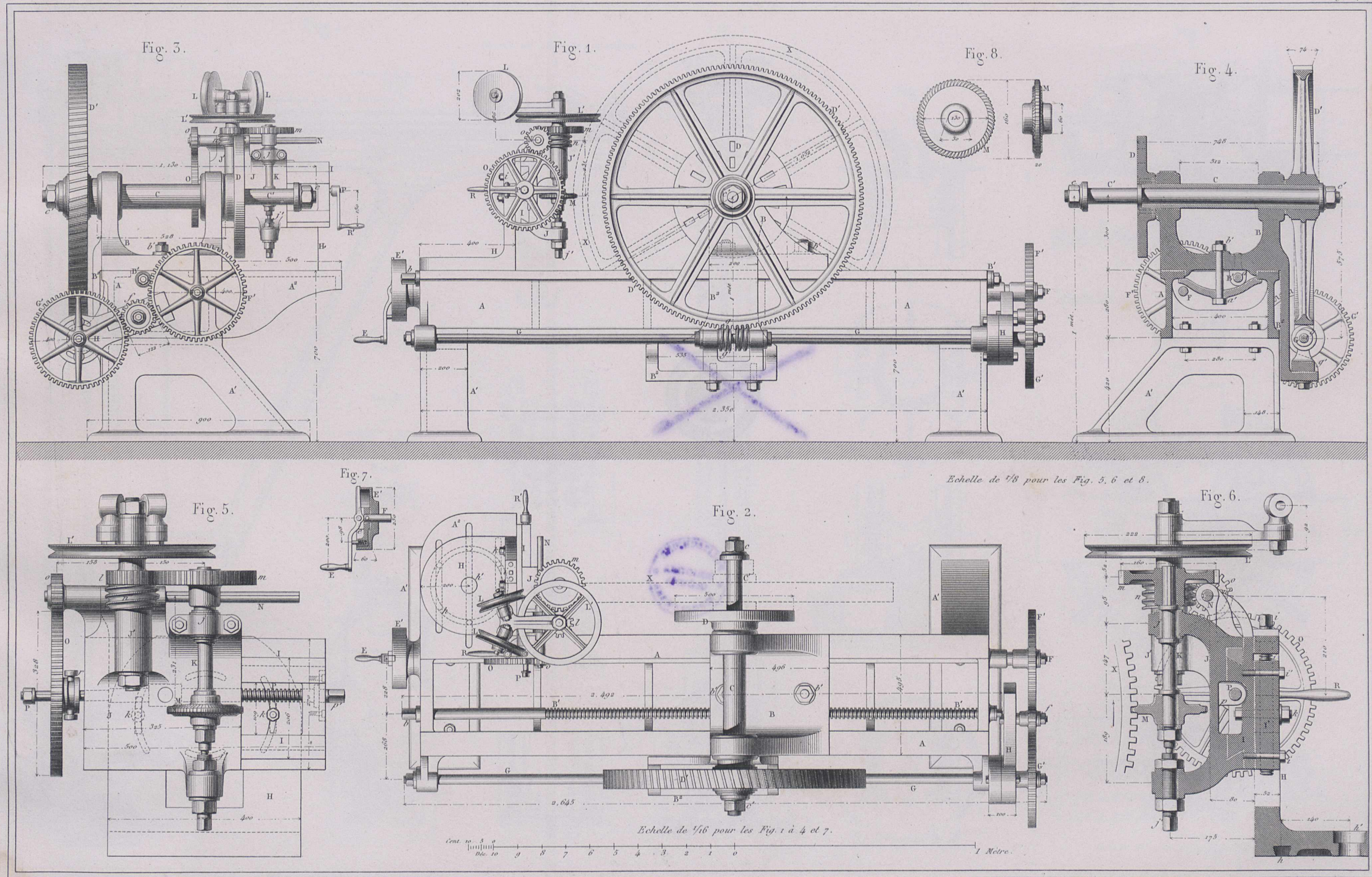
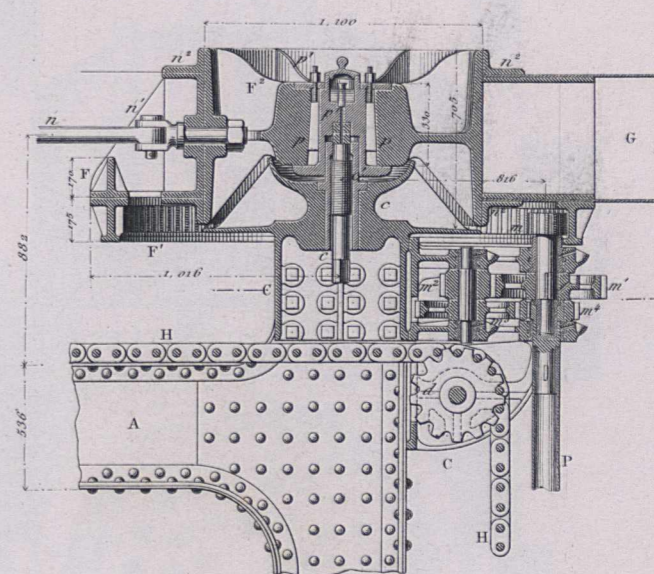
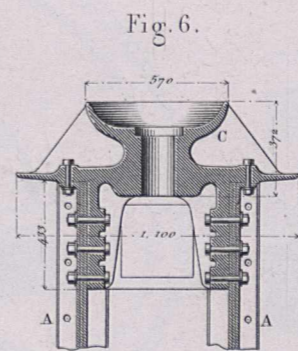
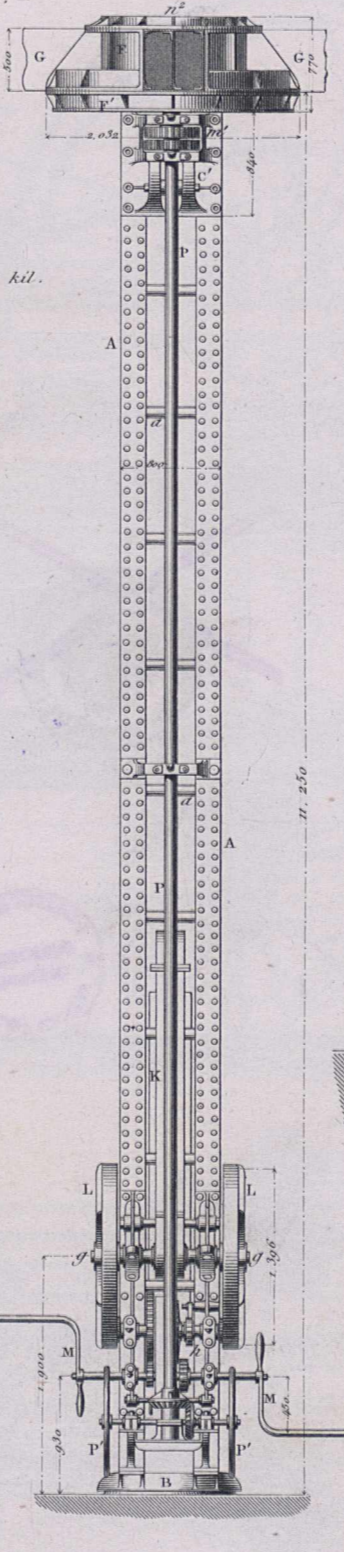
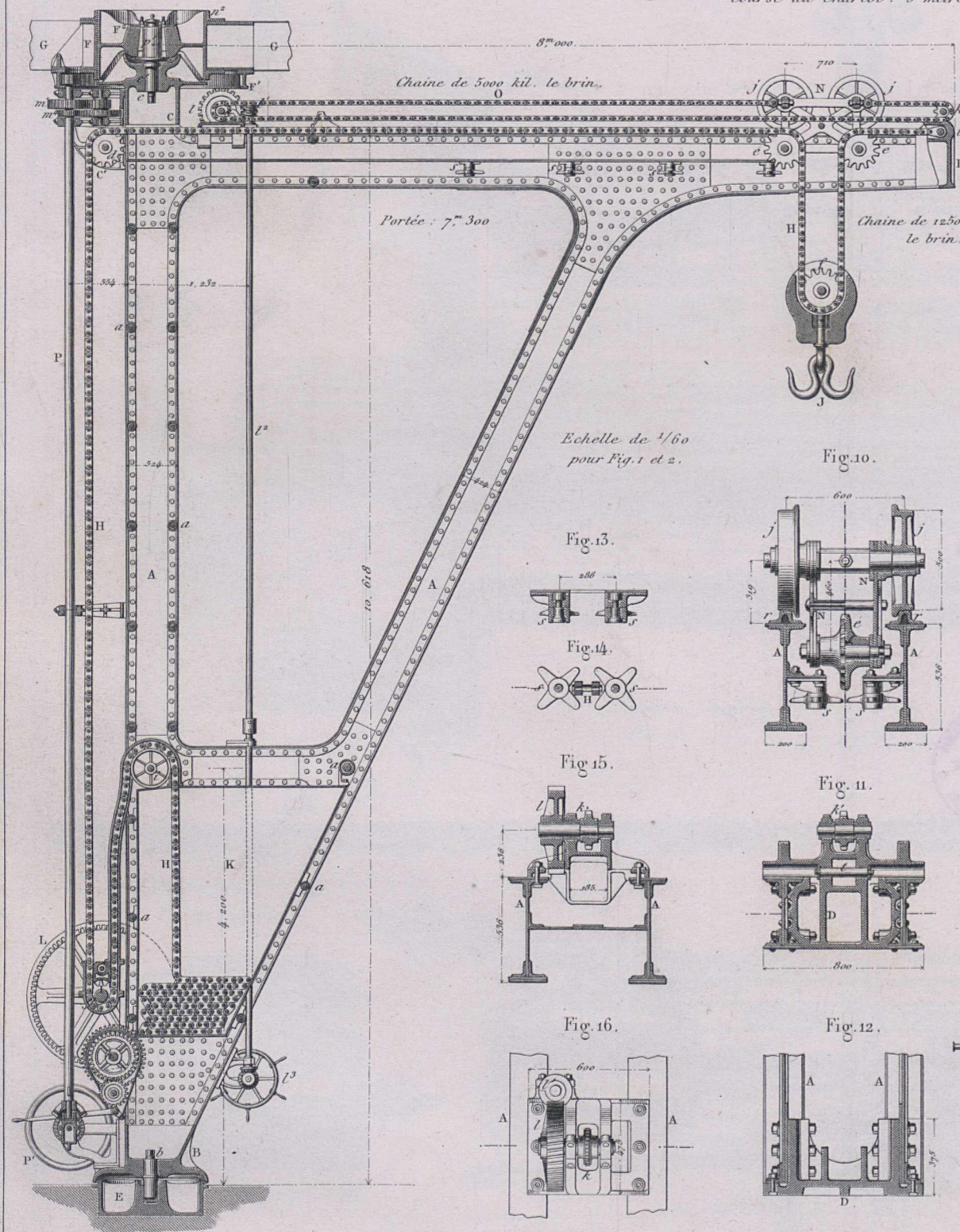



Fig. 1.

Fig. 2.

Fig. 3.



Echelle de 1/60 pour Fig. 1 et 2.

Fig. 10.

Fig. 7.

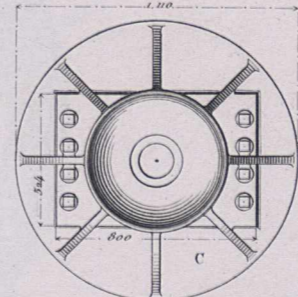

Fig. 4.

Fig. 13.

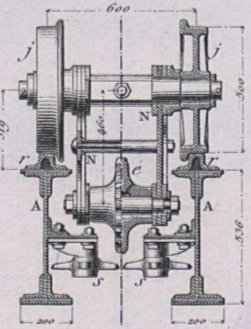

Fig. 8.

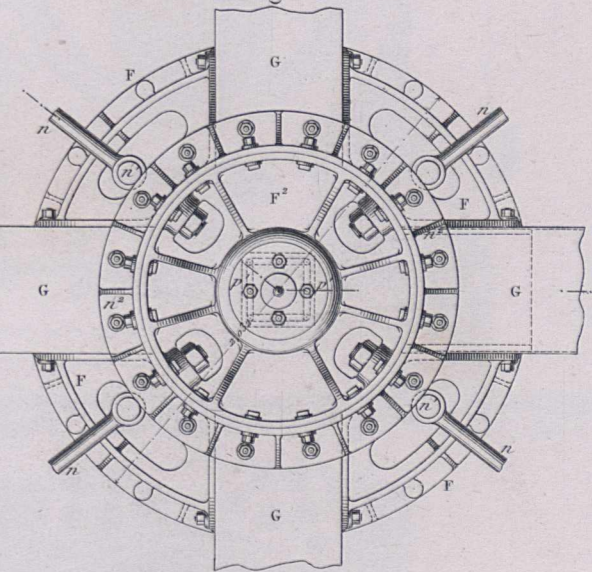
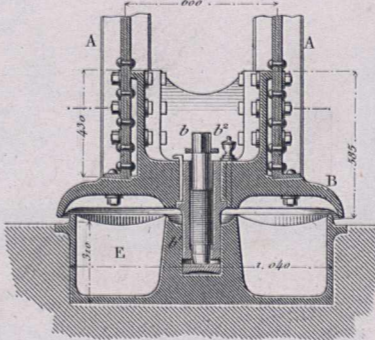

Fig. 14.

Fig. 11.

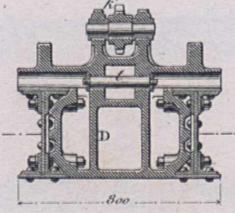
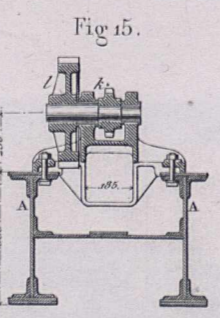

Fig. 9.

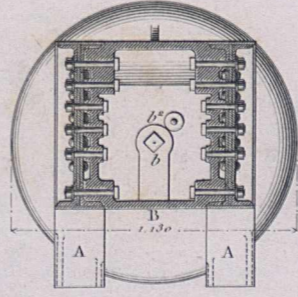
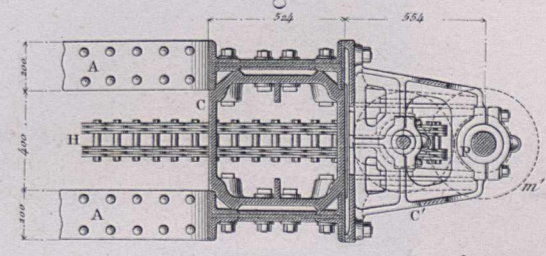
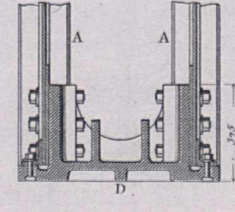
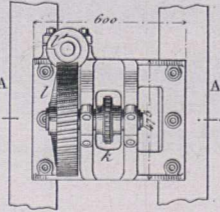

Fig. 5.

Fig. 15.

Fig. 12.



Echelle de 1/30 pour Fig. 3 à 16.



Puissance nominale — 14 chevaux.

Fig. 1.

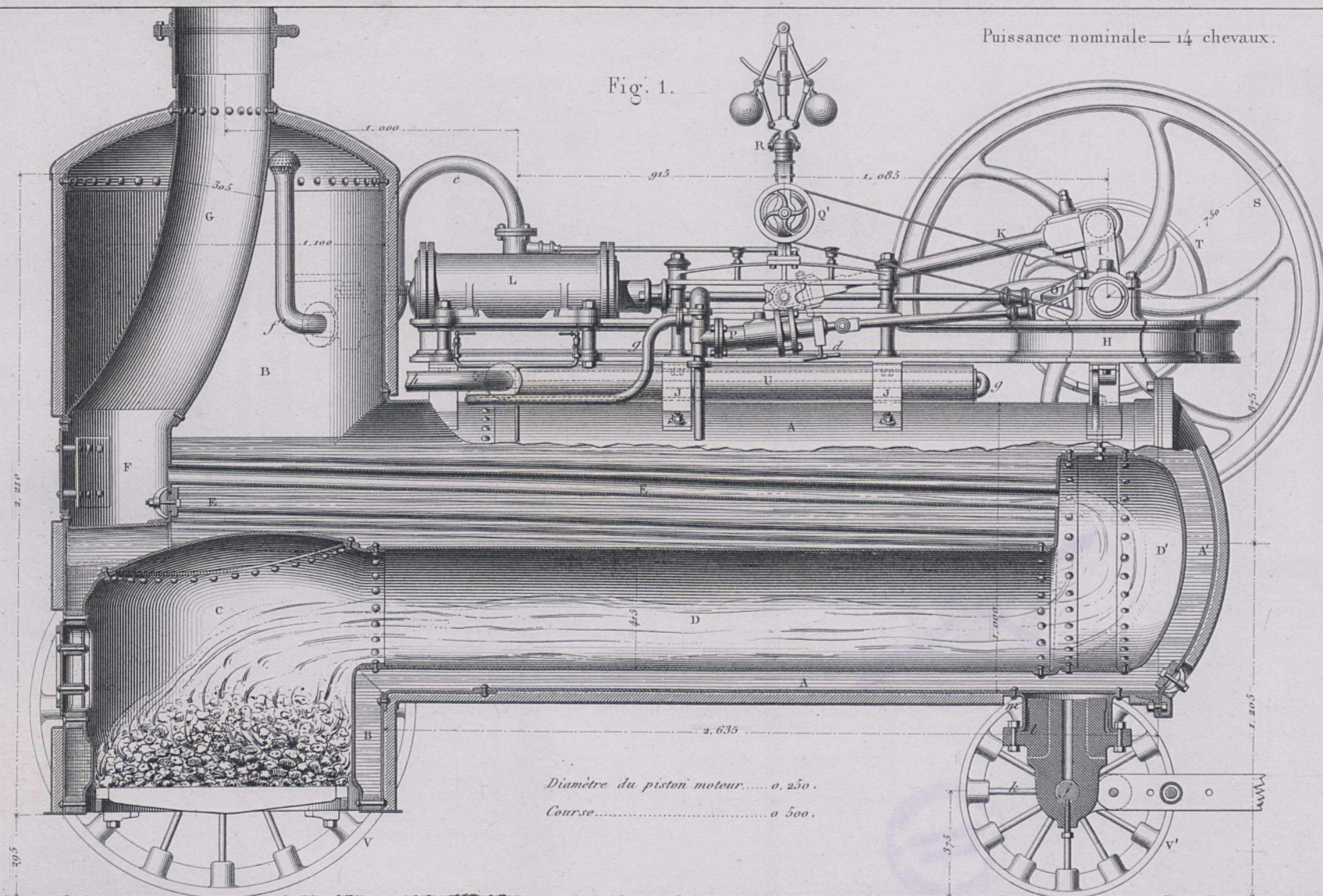

Diamètre du piston moteur..... 0.250.
Course..... 0.500.

Fig. 2.

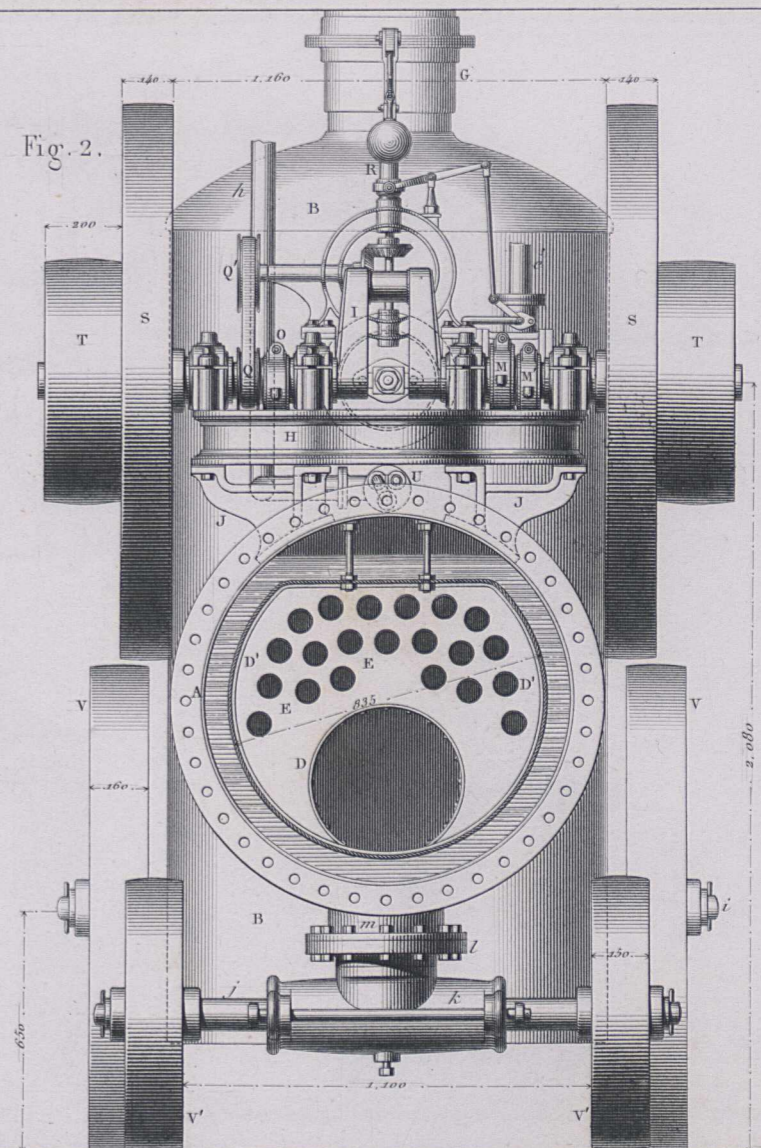

Fig. 5.

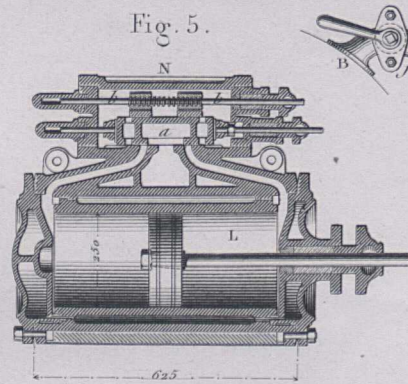
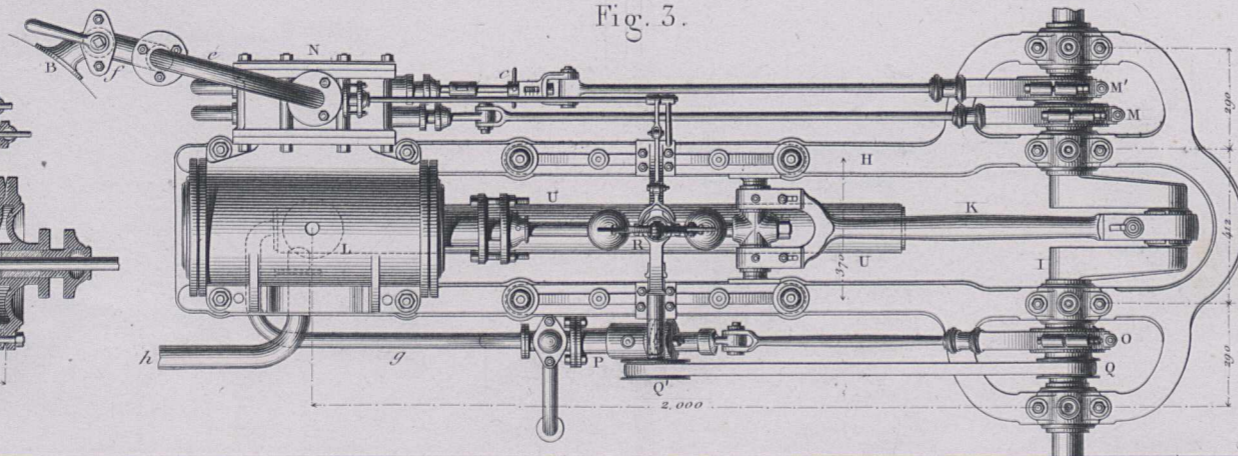
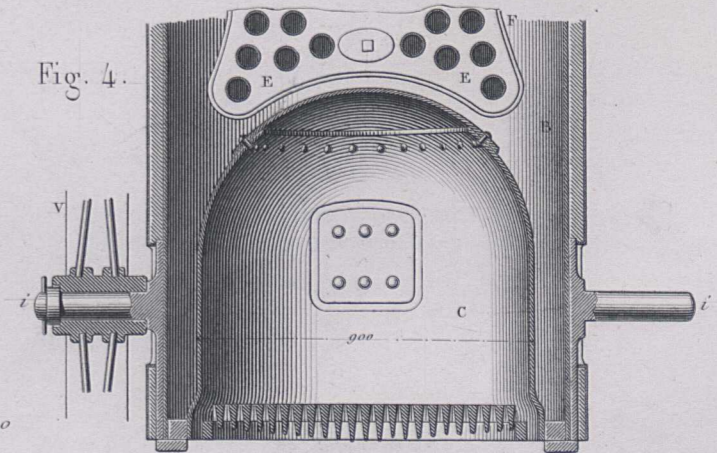

Fig. 3.



Echelle de 1/20

Fig. 4.





Systeme de M. Fairbairn.

Systeme de M. Hulse.

Fig. 1.

Fig. 3.

Fig. 6.

Fig. 4.

Fig. 2.

Fig. 7.

Fig. 5.

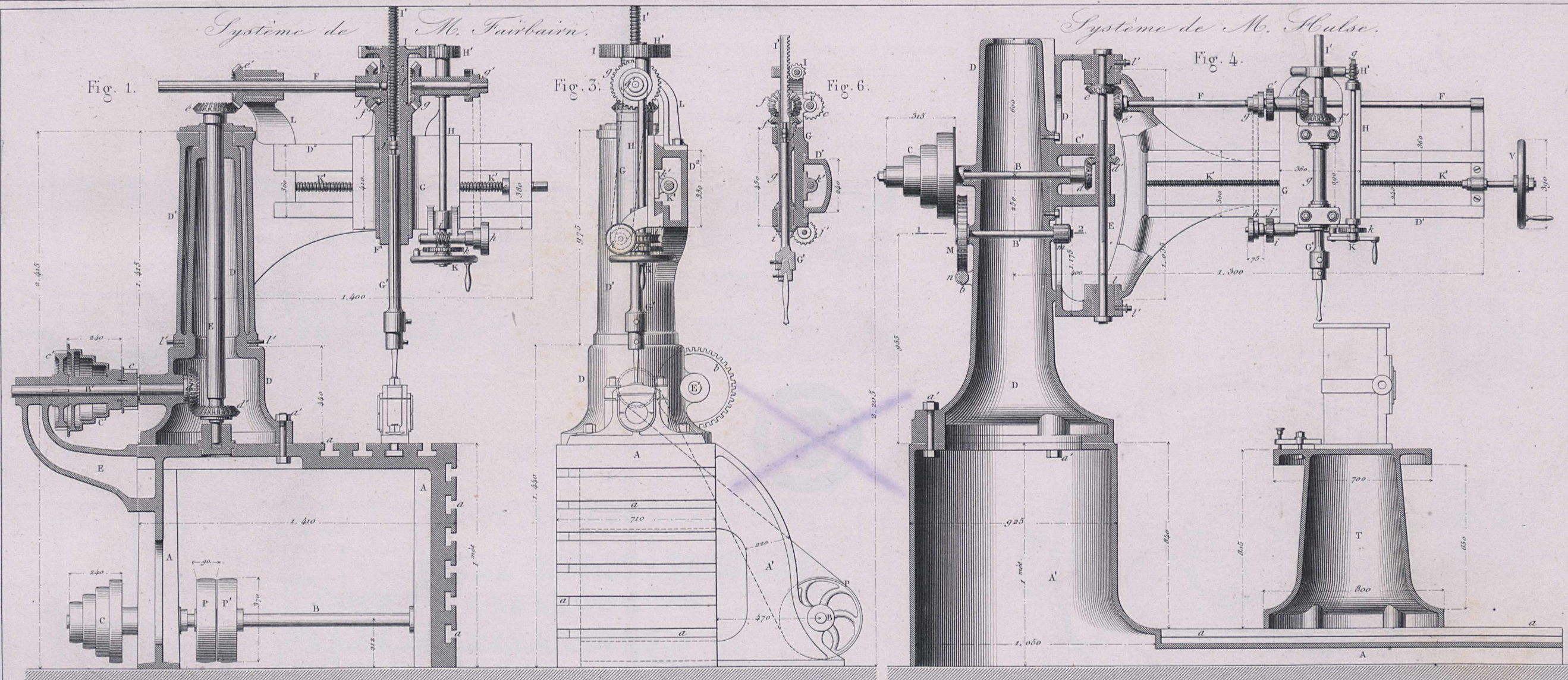

Echelle de 1/20.

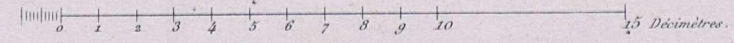

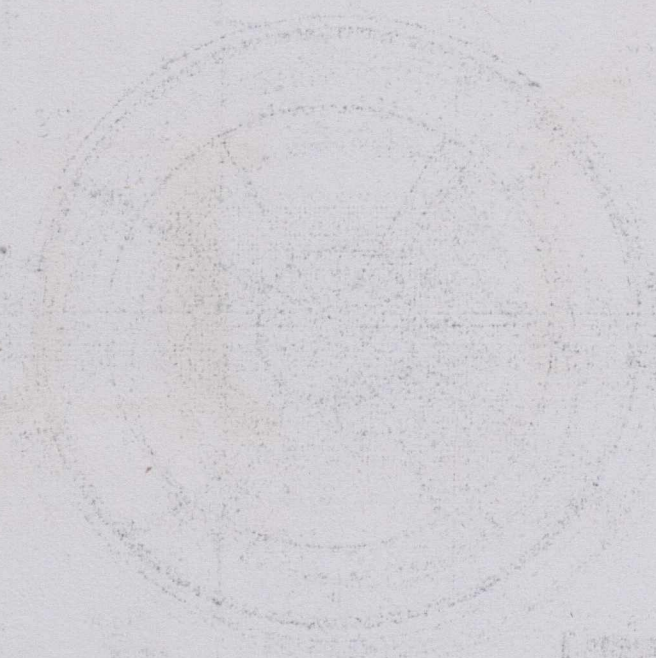
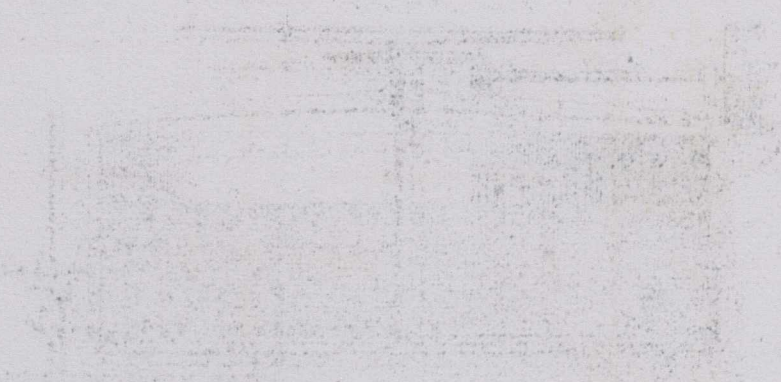

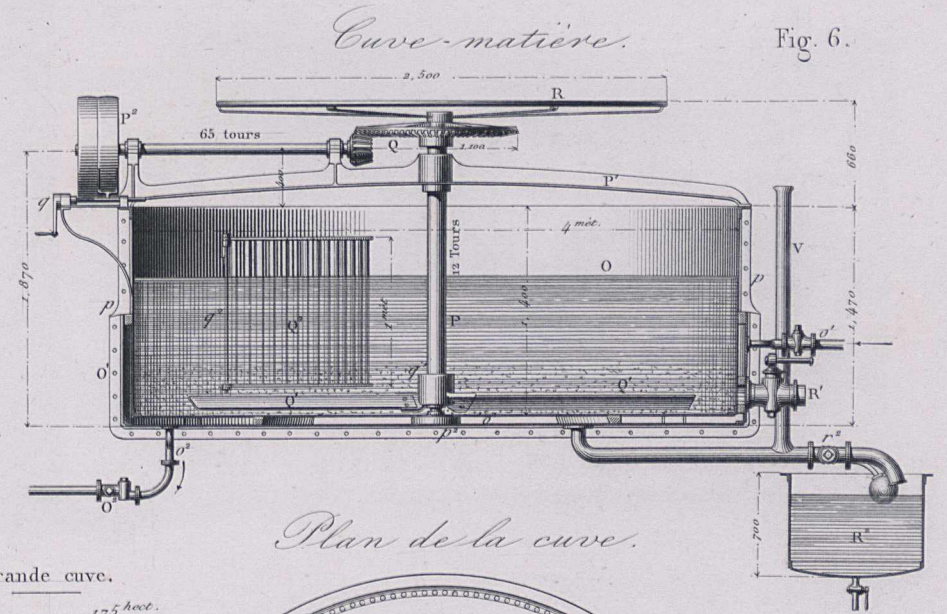
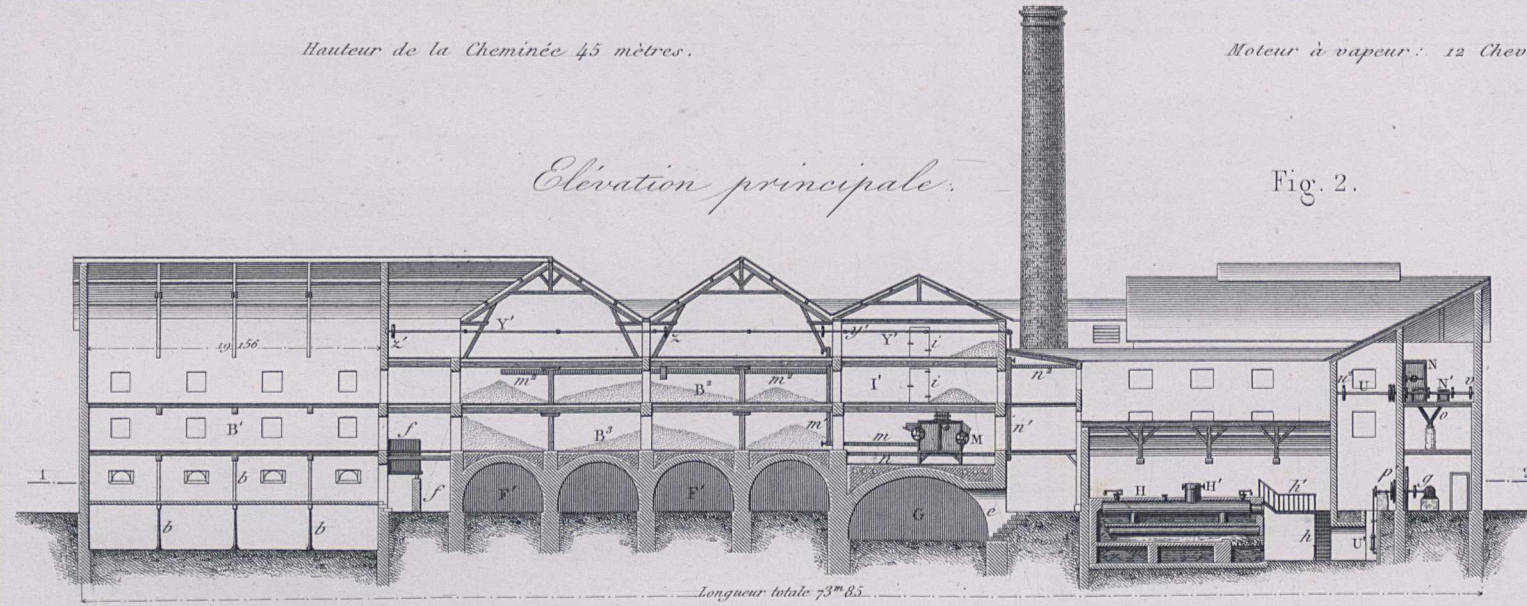

Plan général du rez-de-chaussée.

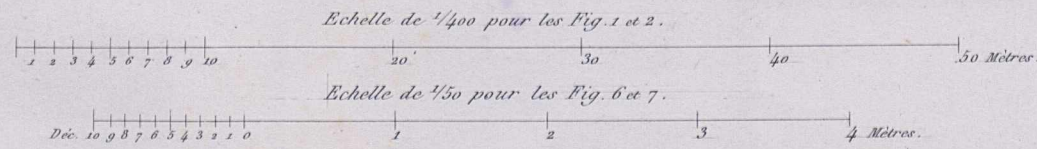
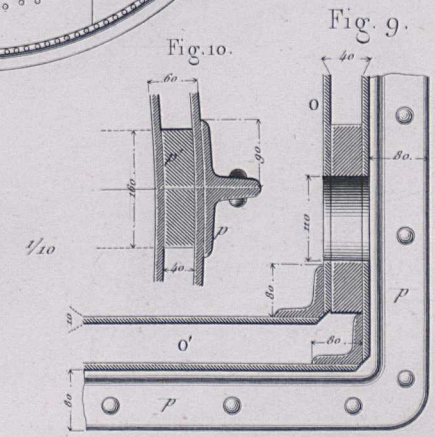
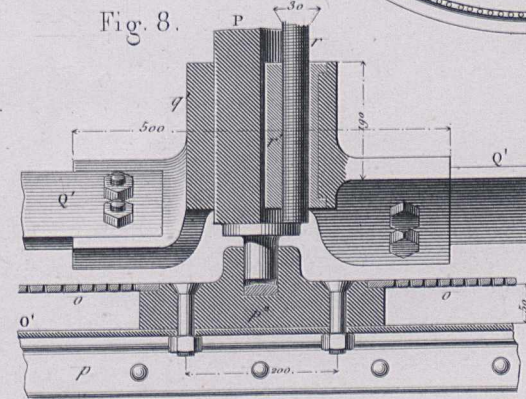
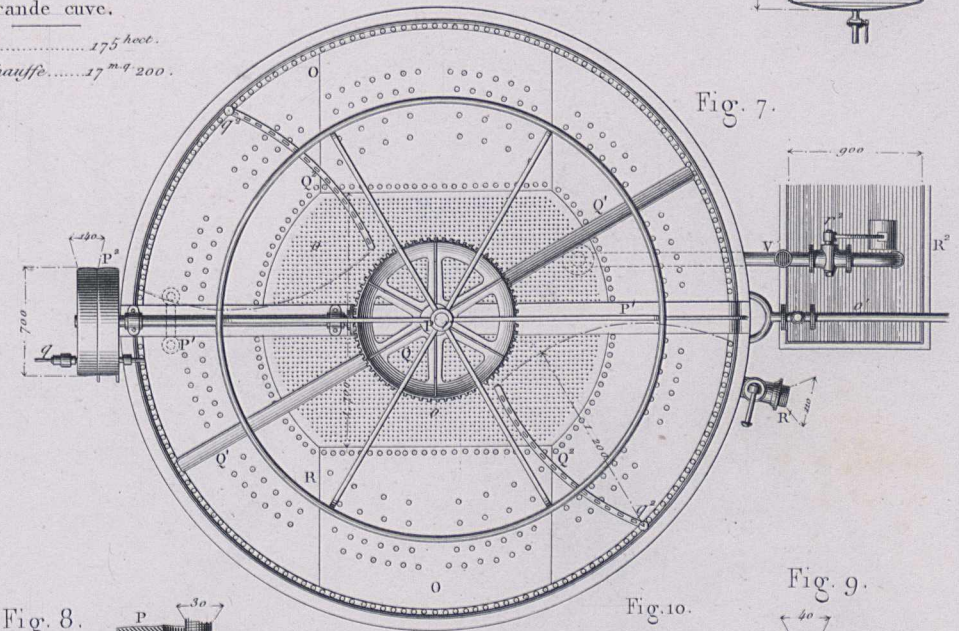
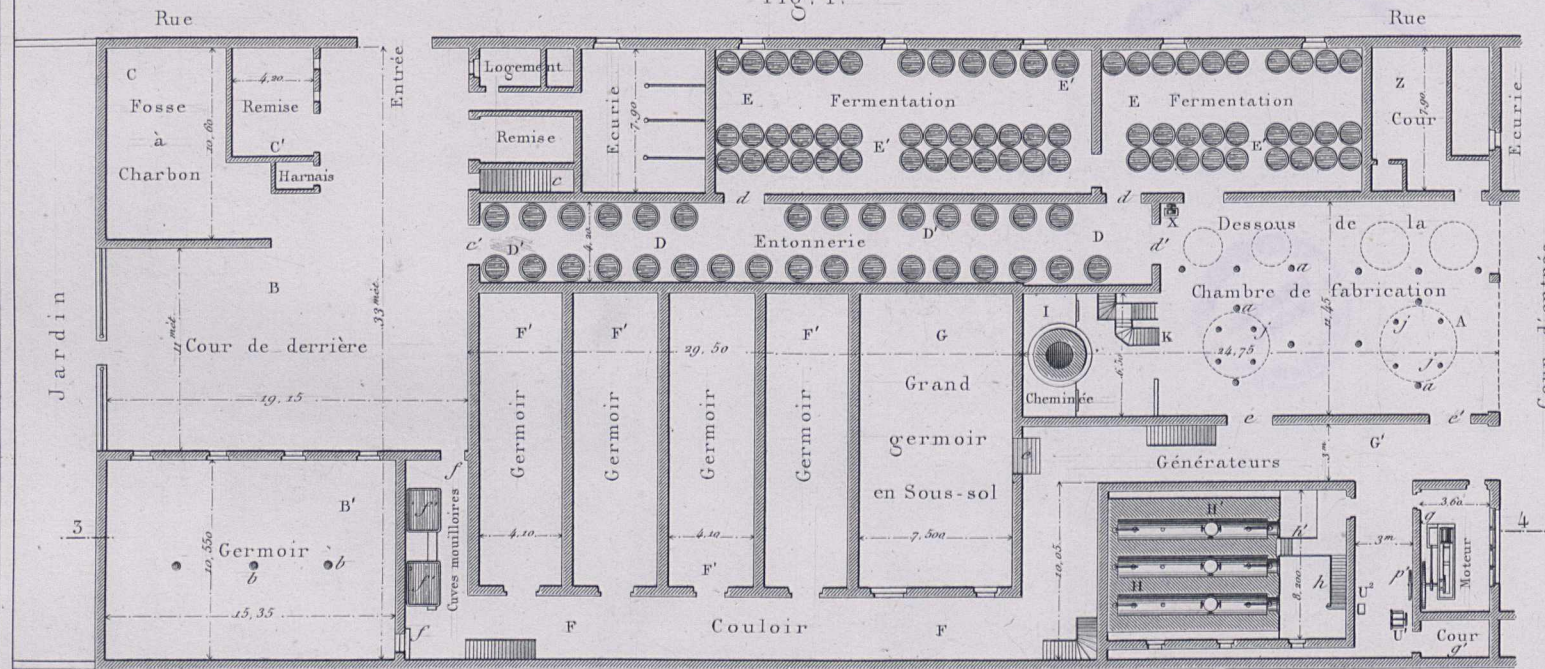



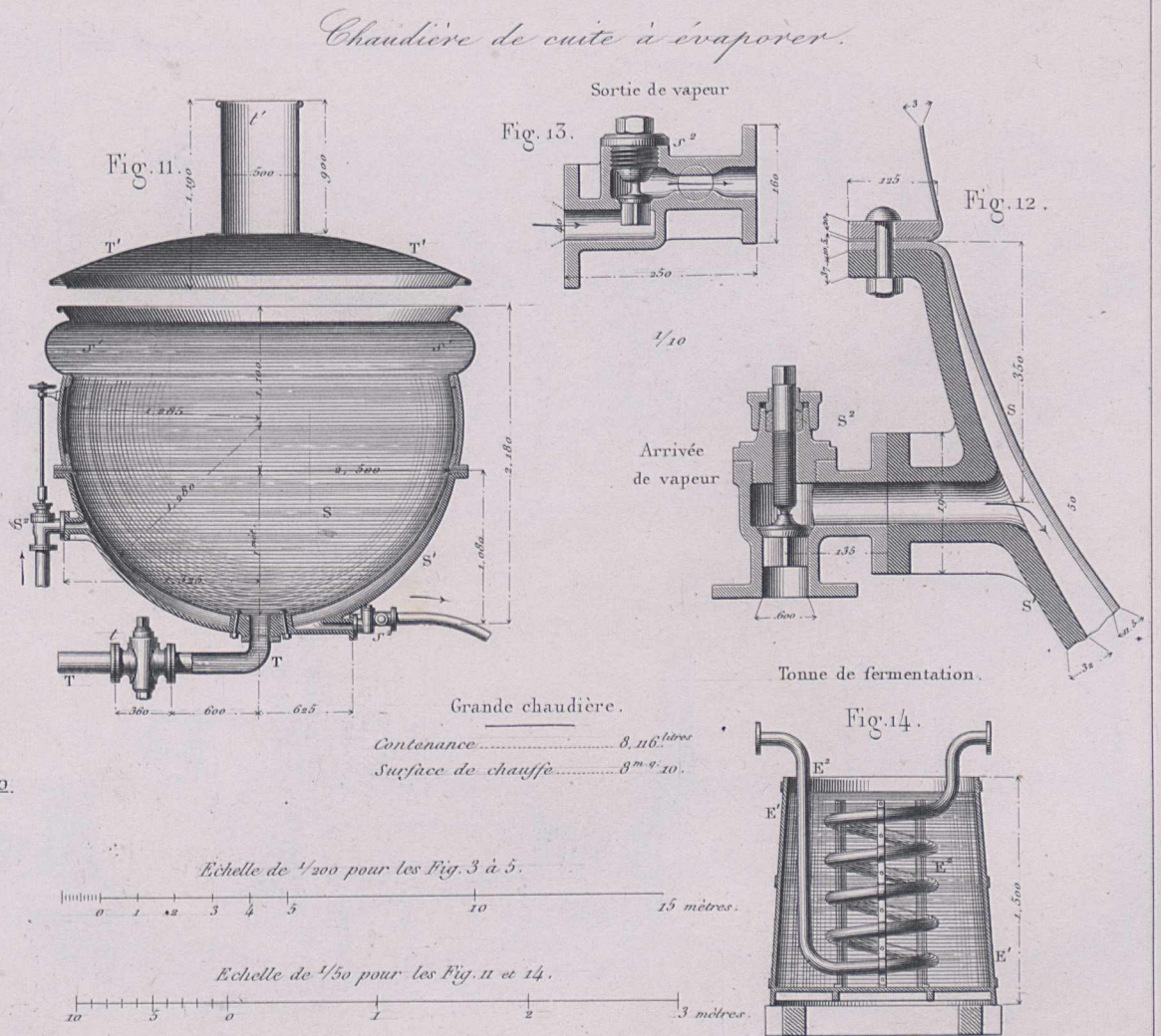
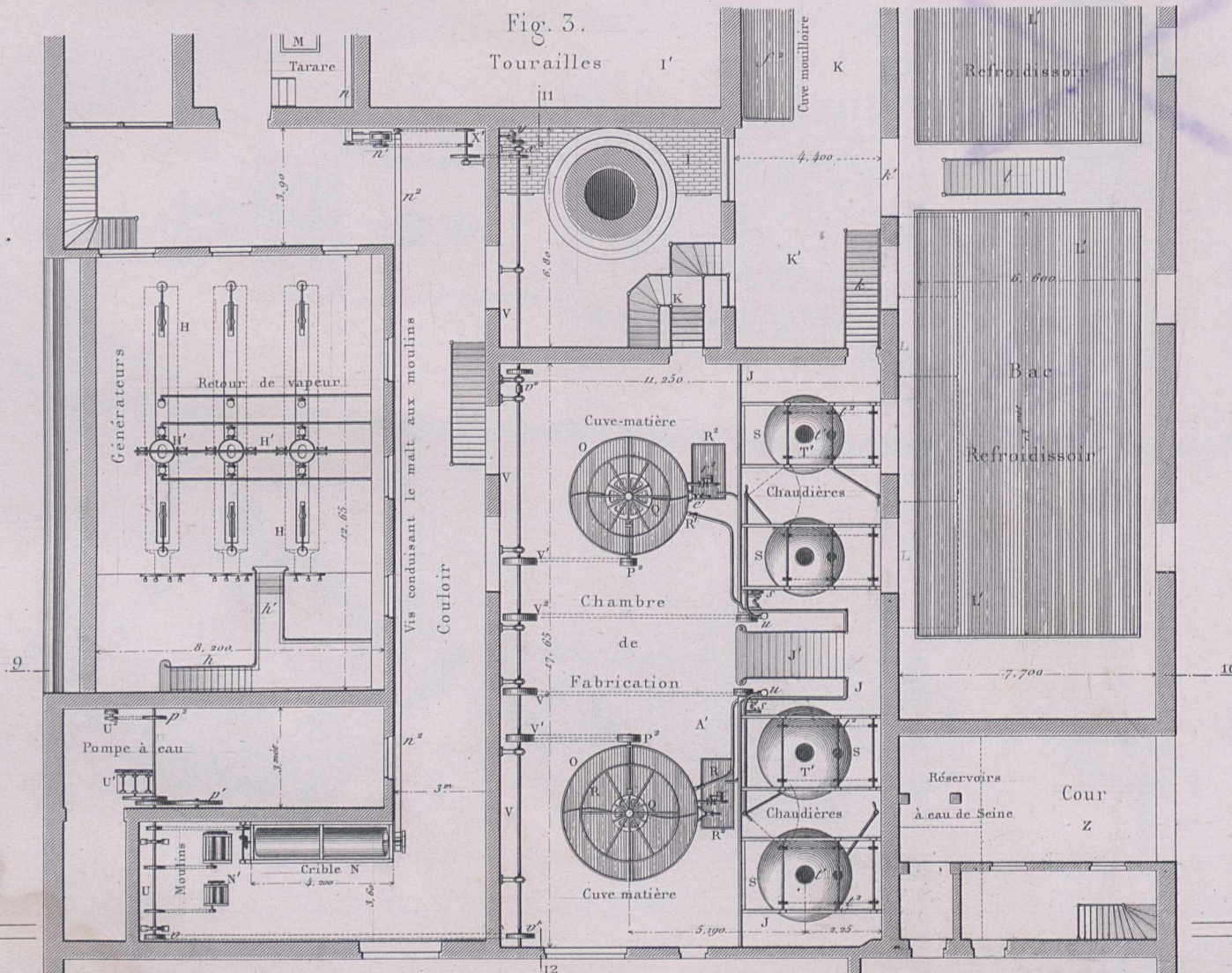
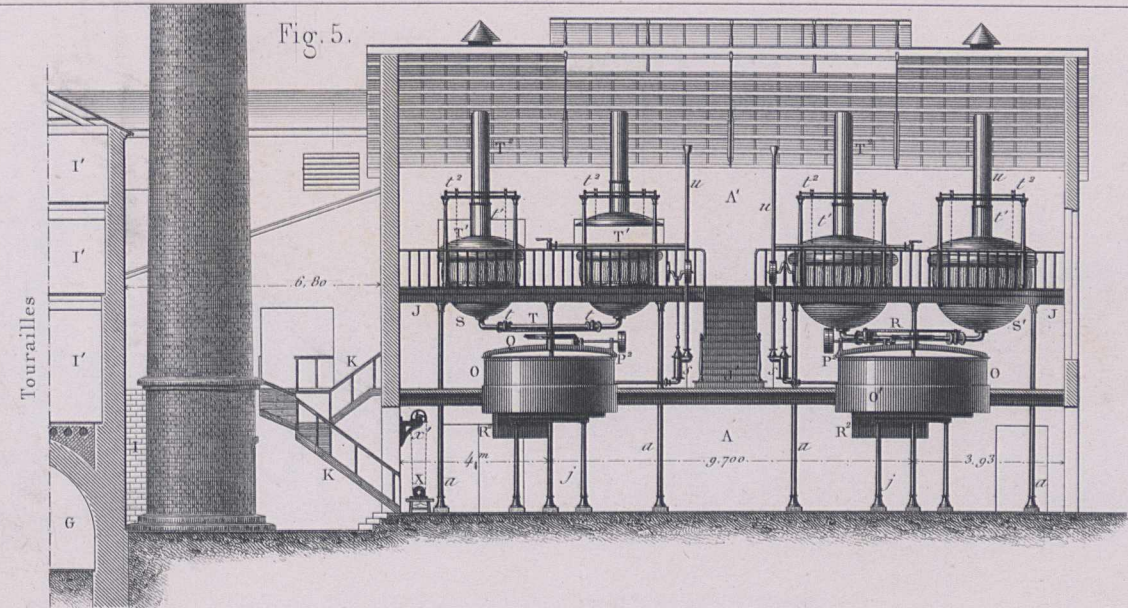
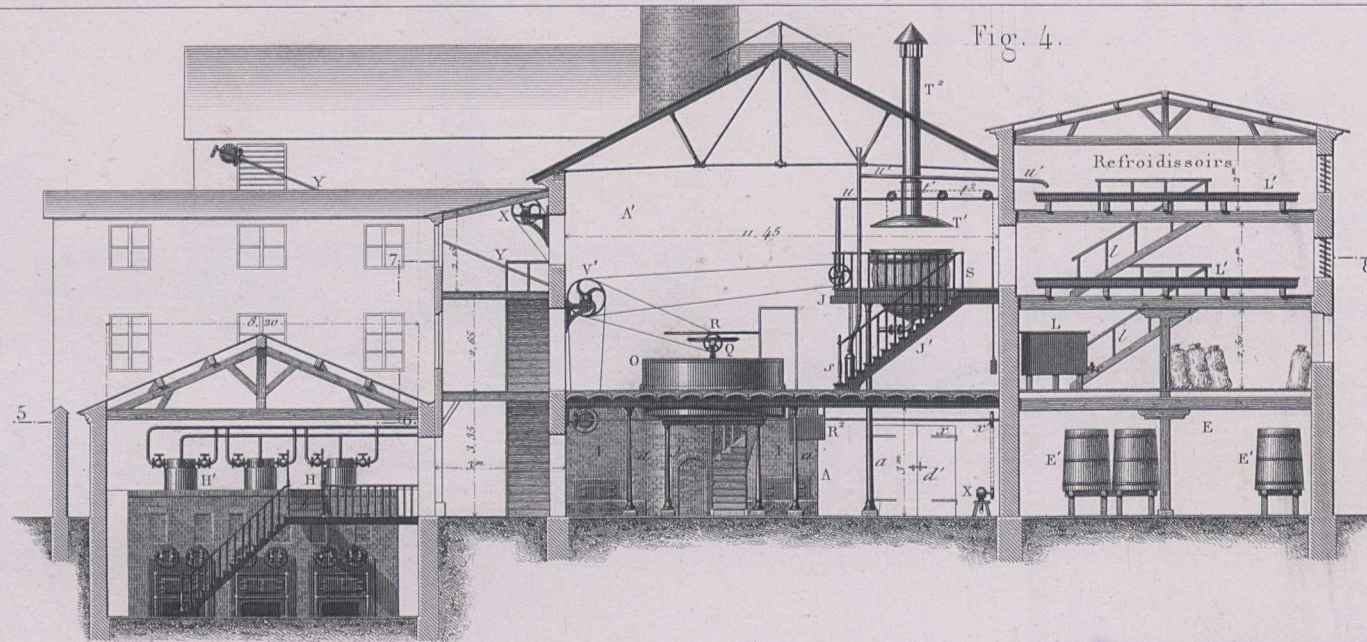



Construit pour le bassin de S^t Nazaire.

Fig. 1.

Tirant d'eau en charge sous quille = 2^m 55.

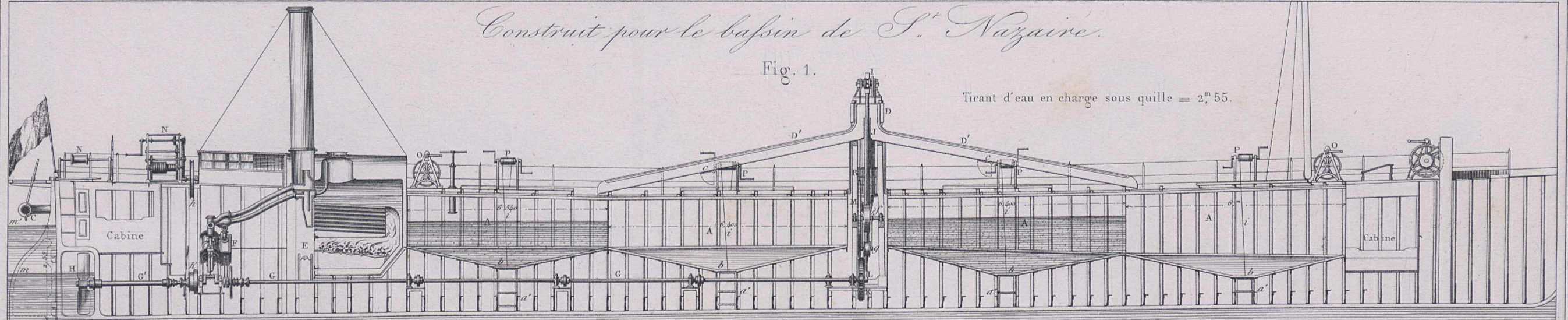
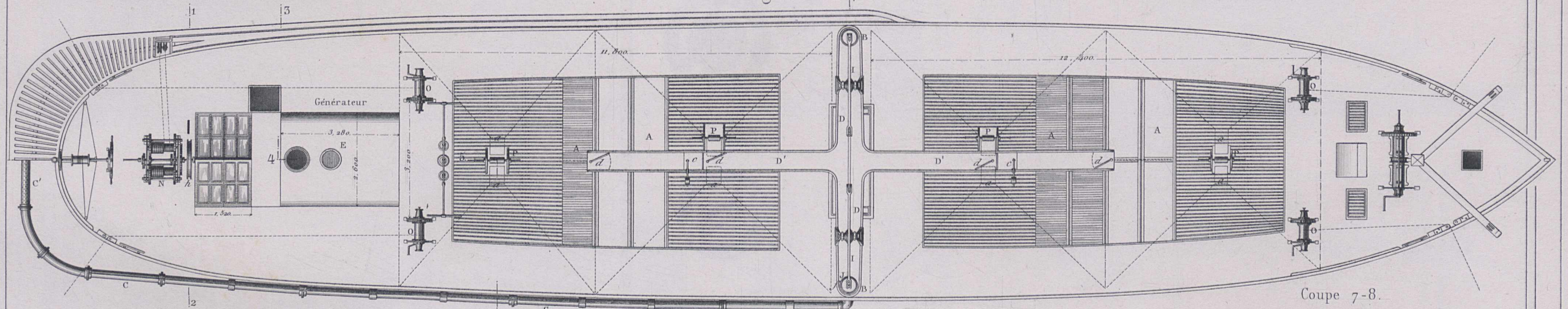

Fig. 2.

Longueur totale du bateau en charge = 41^m 50, à la flottaison.



Machine motrice.

Fig. 6.

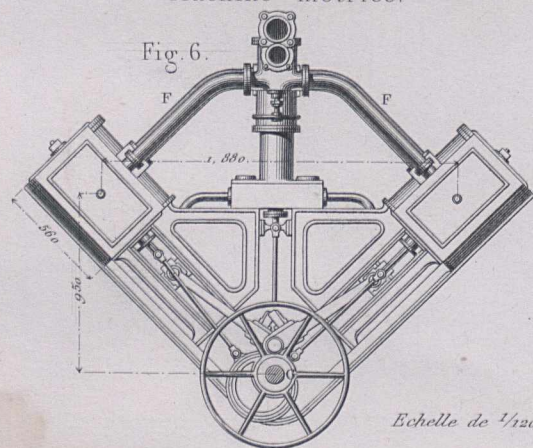

Coupe 1-2.

Fig. 3.

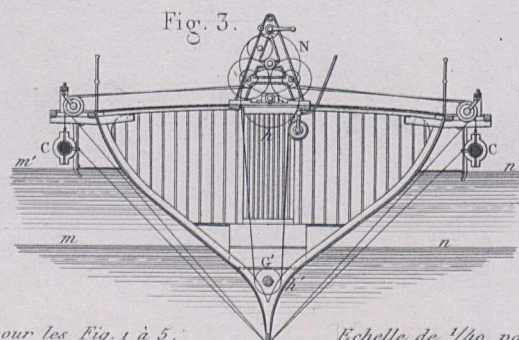

Pompe.

Fig. 7.

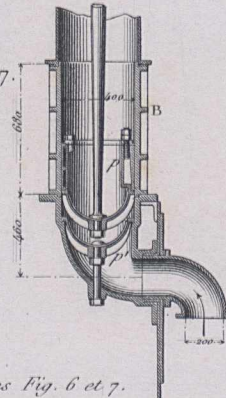

Double coupe 3-4-5-6.

Fig. 4.

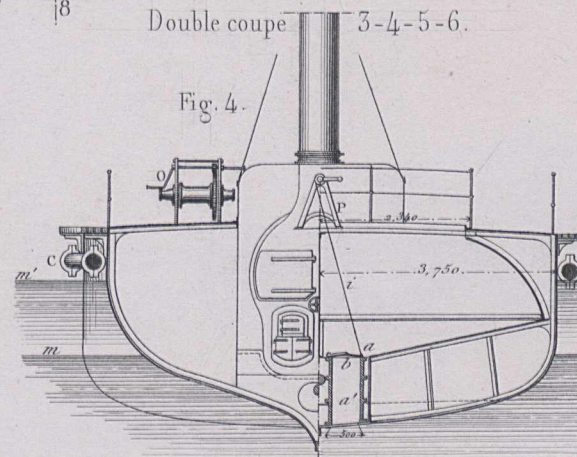

Coupe 7-8.

Fig. 5.

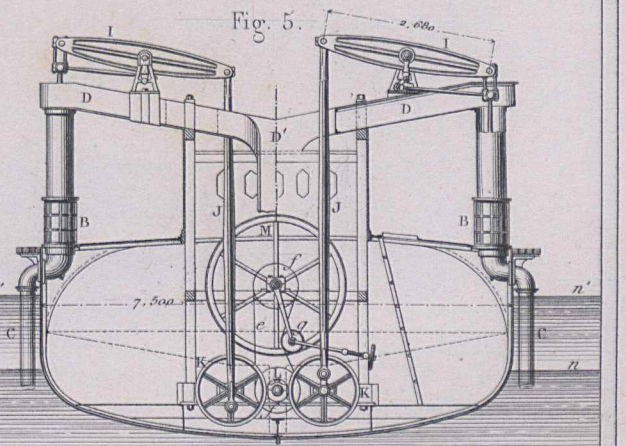

Echelle de 1/120 pour les Fig. 1 à 5.

Echelle de 1/40 pour les Fig. 6 et 7.

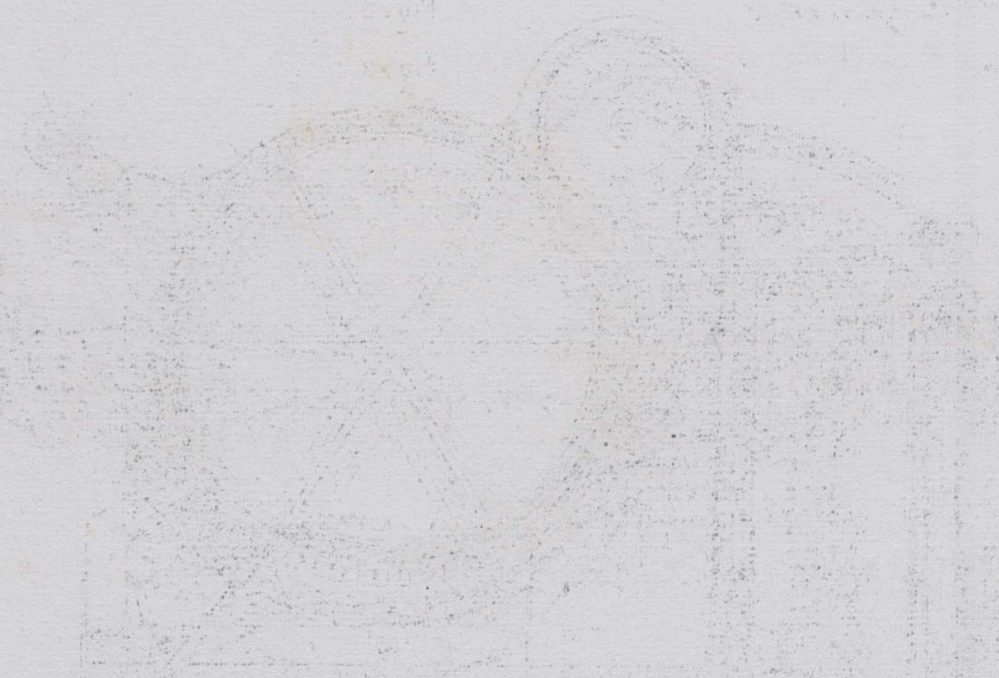

*Application de la mécanique Jacquart.
au déplacement des chapeaux*

Fig. 1.

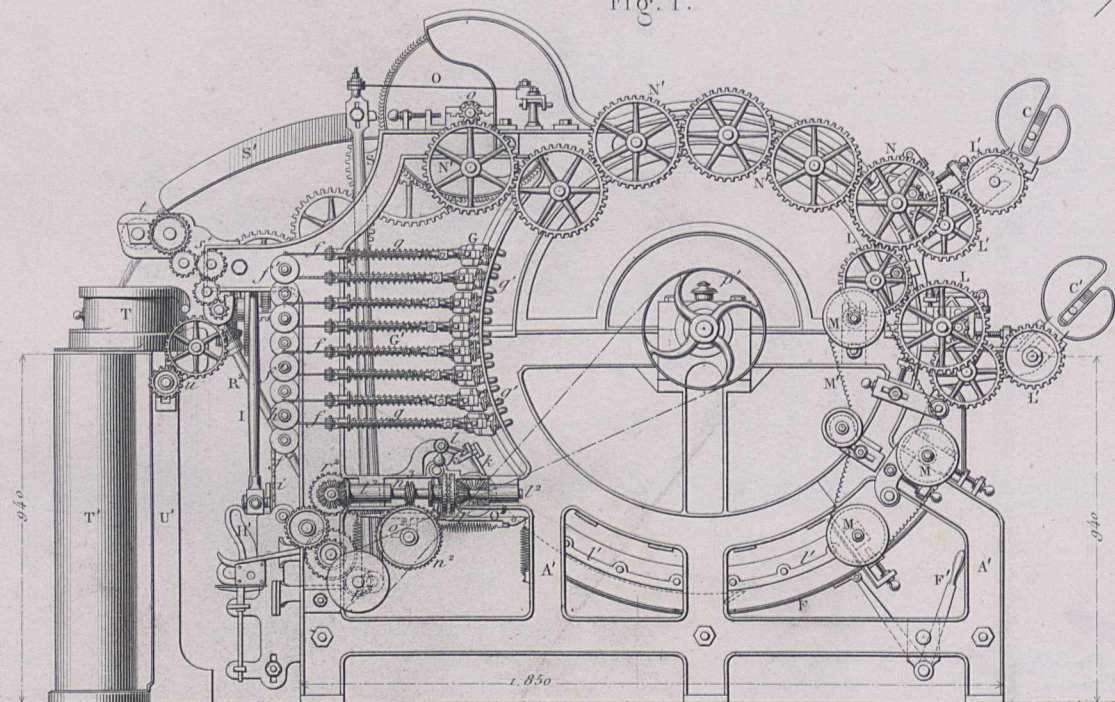

Fig. 2.

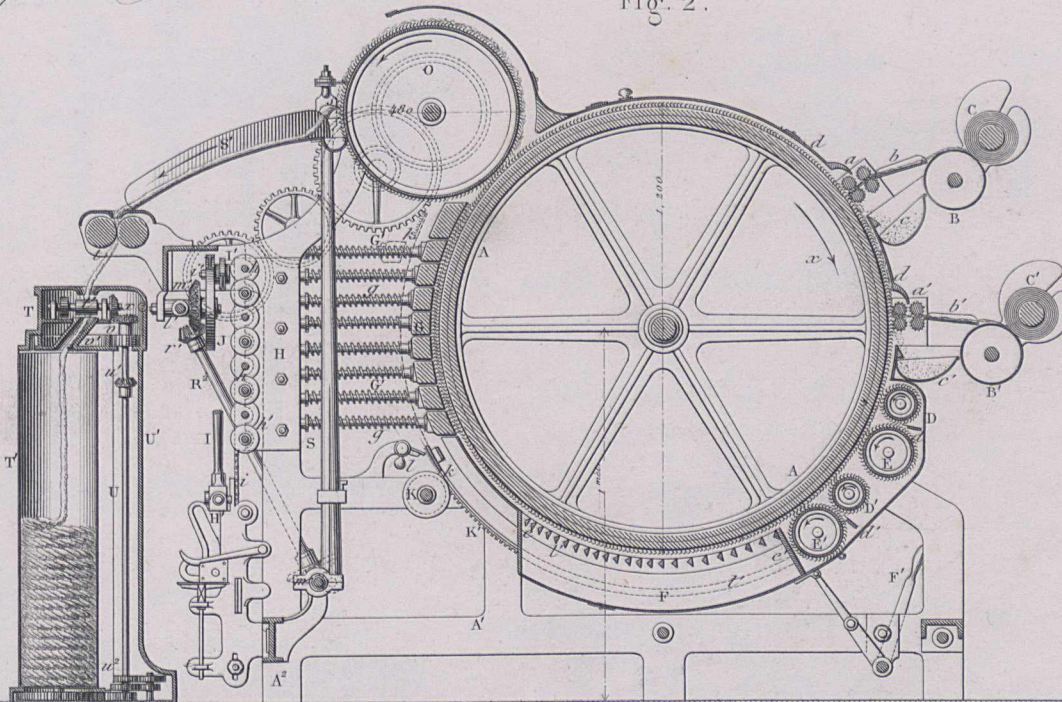

Fig. 4.

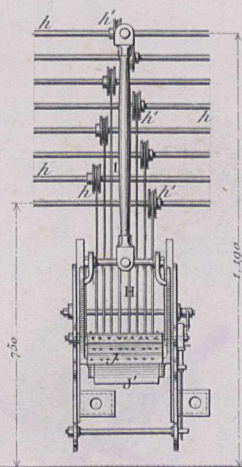

Fig. 3.

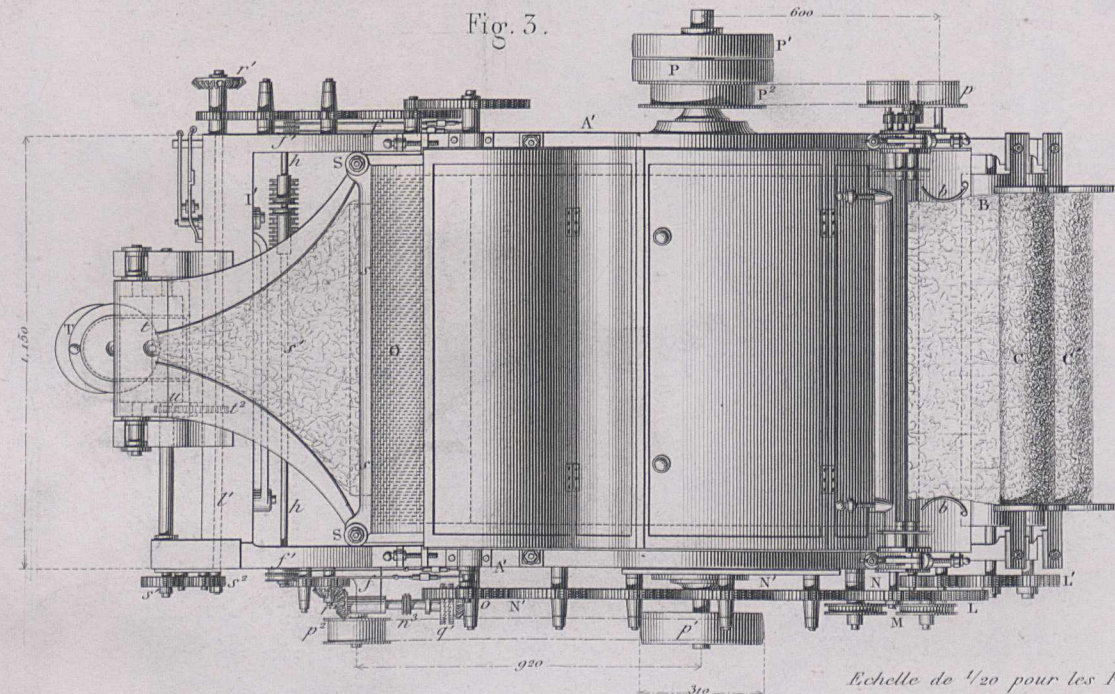

Fig. 5.

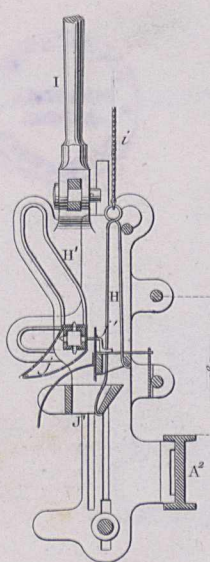

Fig. 6.

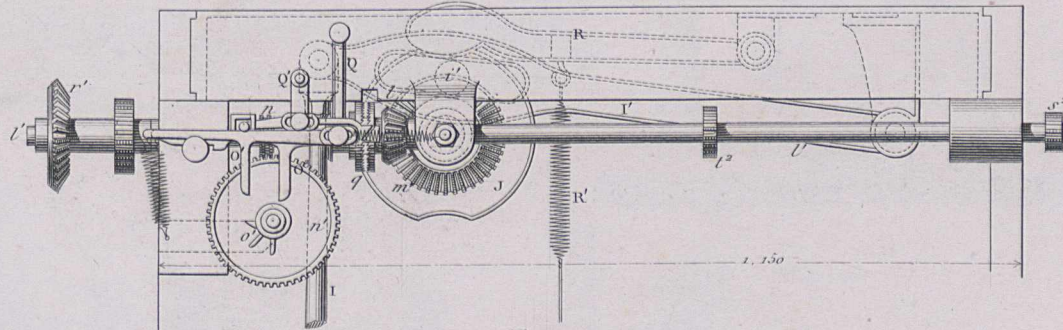
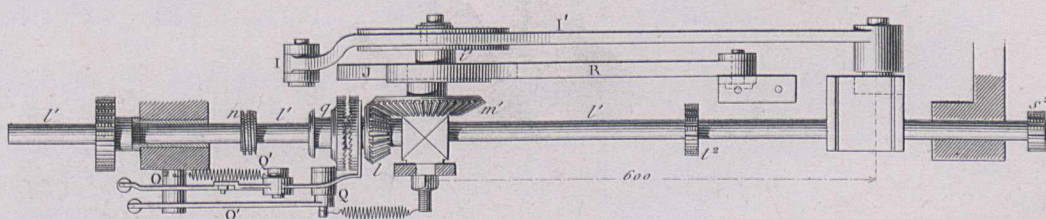

Fig. 7.



Echelle de 1/20 pour les Fig. 1 à 4.

Echelle de 1/10 pour des Fig. 5 à 7.



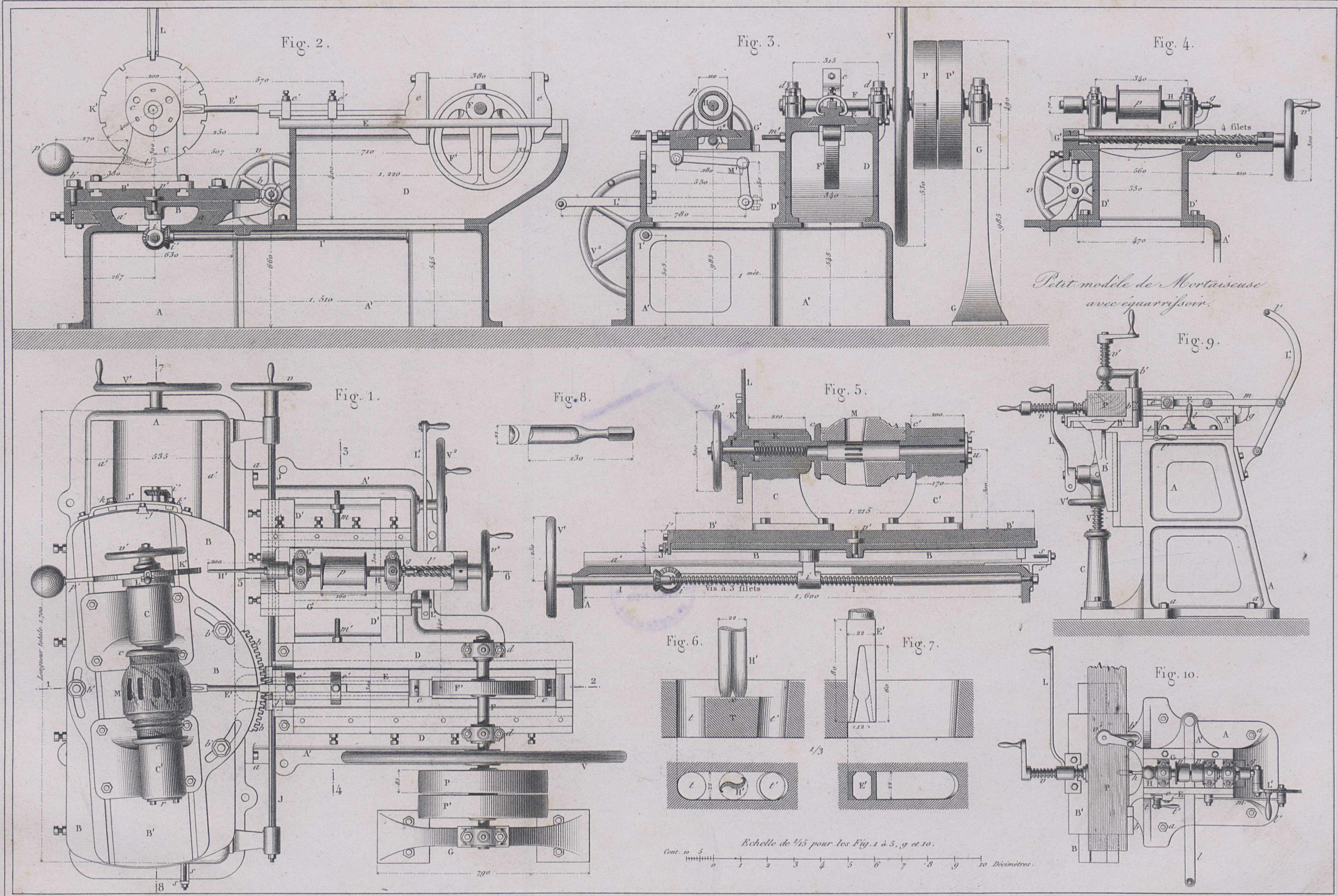

Petit modèle de Mortaiseuse avec équerre pour.

Echelle de 1/10 pour les Fig. 1 à 5, 9 et 10.
Cent. 10 5 0 1 2 3 4 5 6 7 8 9 10 Décimètres.



 BIBLIOTEKA GŁÓWNA
R-96m
ALCHEMIA