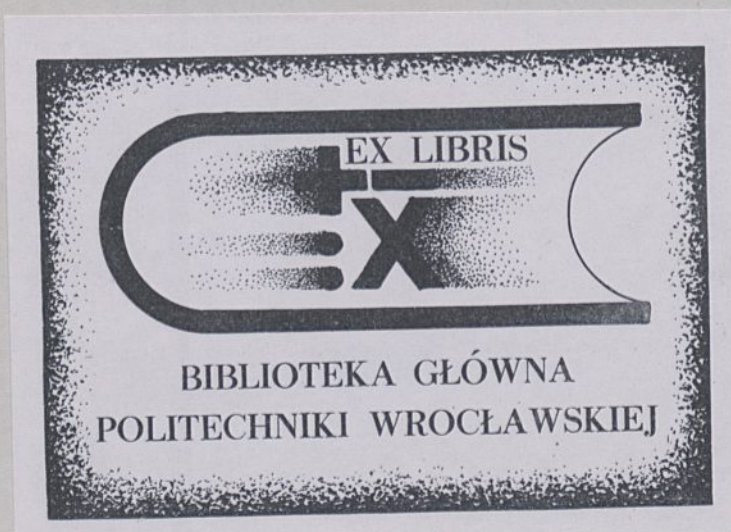


R 96
m

Archiwum



PUBLICATION INDUSTRIELLE
DES
MACHINES, OUTILS ET APPAREILS

LES PLUS PERFECTIONNÉS ET LES PLUS RÉCENTS

EMPLOYÉS

DANS LES DIFFÉRENTES BRANCHES DE L'INDUSTRIE FRANÇAISE ET ÉTRANGÈRE

PAR

ARMENGAUD AINÉ

INGÉNIEUR, ANCIEN PROFESSEUR AU CONSERVATOIRE IMPÉRIAL DES ARTS ET MÉTIERS

CHEVALIER DE LA LÉGION D'HONNEUR

MEMBRE HONORAIRE DE LA SOCIÉTÉ PHILOMATIQUE DE BORDEAUX ET DE LA SOCIÉTÉ INDUSTRIELLE DE MULHOUSE, MEMBRE DE LA SOCIÉTÉ D'ENCOURAGEMENT, DE LA SOCIÉTÉ DES INGÉNIEURS CIVILS, ETC.

TOME QUINZIÈME

PLANCHES

Reproduction interdite.

1912, 499,

Toute communication concernant la rédaction doit être adressée
directement à l'auteur-éditeur :

M. ARMENGAUD AINÉ

INGÉNIEUR

45, RUE SAINT-SÉBASTIEN, A PARIS

Tout ce qui concerne le service des abonnements et la vente des
volumes doit être adressé à

MM. A. MOREL ET C^{IE}

LIBRAIRES

43, RUE BONAPARTE, A PARIS

PUBLICATION INDUSTRIELLE

DES

MACHINES, OUTILS ET APPAREILS

LES PLUS PERFECTIONNÉES ET LES PLUS RÉCENTES

EMPLOYÉES

DANS LES DIFFÉRENTES BRANCHES DE L'INDUSTRIE FRANÇAISE ET ÉTRANGÈRE



ARMEGAUD AINÉ



N. 24924

TOME QUINZIÈME

PARIS 1884

Publication française

M. A. MORÉ ET C^{ie}

M. ARMEGAUD AINÉ

TABLE DES PLANCHES

DU TOME QUINZIÈME DE LA PUBLICATION INDUSTRIELLE

PLANCHES.	1 ^{re} LIVRAISON.	PAGES.	PLANCHES.	6 ^e LIVRAISON.	PAGES.
1	Sucrerie de betteraves établie à Barberie (Oise), par MM. CAIL et C ^{ie} . — Détails des presses à vis, chaudière de cuite, etc....	3	21	Préparation au tissage. — Ourdissoir pour chaîne-laine. — Filature de laine peignée. — Machine à faire les cannelles.....	234
2					
3					
4		Filature de laine peignée. — Machine de préparation du deuxième degré. — Bobinoir réunisseur, exécuté par M. BRUNEAUX fils aîné, mécanicien et filateur à Rethel.....	57		
5					
6					
7					
8	Train de laminoirs à guides pour petits fers, exécuté sous la direction de MM. THIRION et DE MASTAING.....	86	23	Machine à égrener les cotons de divers systèmes.....	266
2 ^e LIVRAISON.			24	<i>Id. id.</i> par M. F. DURAND.....	283
5	Filature de laine peignée. — Bobinoir double finisseur, par M. BRUNEAUX.	57	7 ^e LIVRAISON.		
6	Ensemble de forge. — Usine de Rachecourt à MM. COLAS FRÈRES.	73	25	Four à gaz et à chaleur régénérée, par MM. W. et F. SIEMENS.....	293
7			— Transmission de mouvement par poulies et courroies.....	26	Préparation au tissage. — Machine à encoller les fils de chaîne, système FASSIN, construite par M. BRUNEAUX.....
8	Train de laminoirs à guides pour petits fers, exécuté sous la direction de MM. THIRION et DE MASTAING.....	86	27	Hache-paille de divers systèmes construits par MM. ALBARET et C ^{ie} ..	317
3 ^e LIVRAISON.			28	Appareils propres à l'affinage de la fonte, par le procédé BESSEMER..	325
9	Générateurs à vapeur chauffés par 4 fours à puddler.....	91	8 ^e LIVRAISON.		
10	Machine à assouplir le chanvre, par MM. LALLIER et BRIÈRE.....	107	29	Machine à corroyer, planer et dresser les madriers, longerons, etc., inventée par M. MARÉCHAL, construite par MM. ARBEY et C ^{ie}	352
11	Bateau avec grande cloche à plongeur et double drague à vapeur, par MM. CAVÉ FRÈRES.....	119	30	Machine à mouler la pâte céramique, par M. F. DURAND.....	371
12	Métier à filer Mull-Jenny dit Box-Organ, par M. BRUNEAUX.....	133	31	Machine à forger et façonner à plusieurs marteaux et matrices.....	383
4 ^e LIVRAISON.			32	Métier mécanique à tisser la toile, par M. BRUNEAUX.....	389
13	Métier à filer Mull-Jenny dit Box-Organ, par M. BRUNEAUX.....	133	9 ^e LIVRAISON.		
14	Fabrication de verre. — Chauffage des fours à vitre par les gaz des fours à coke, par MM. VENINI.....	153	33	Métier mécanique à tisser le mérinos, par M. BRUNEAUX.....	402
15	Pompe à vapeur pour épuisement, par MM. LE BRUN et L'ÉVÊQUE...	173	34	Gros mécanisme d'un moulin à blé mû par turbine, construit par MM. FONTAINE et BRAULT, à Chartres.....	417
16	Conservation des bois. — Étuve de dessiccation et appareil d'injection, par MM. DORSETT et BLYTHE.....	179	35	Mécanismes de moulin à blé à pignon débrayant.....	430
5 ^e LIVRAISON.			36	Machine à creuser les canaux et les rivières, enlevant et transportant les matières, par MM. A. CAVÉ et CLAPARÈDE.....	439
17	Conservation des bois. — Appareils transportables et locomobiles....	199	10 ^e LIVRAISON.		
18	Machine à fabriquer les rivets, construite par MM. GOUIN et C ^{ie}	207	37	Appareils pour fabriquer la glace, par MM. CARRÉ et C ^{ie}	453
19	Épuisement des formes de carénage. — Appareils utilisant la force des marées, par MM. FONTAINE et BRAULT.....	219	38	Coupe-racines de divers systèmes.....	473
20	Préparation au tissage. — Machine à bobiner, par M. BRUNEAUX....	230	39	Machines-outils. — Machine à mortaiser et rainner les métaux à outil rotatif, par MM. SHARP, STEVART et C ^{ie}	483
			40	Machine à fondre les caractères d'imprimerie, par M. FOUCHER.....	493

Fig. 2. Coupe longitudinale du bâtiment principal de l'usine.

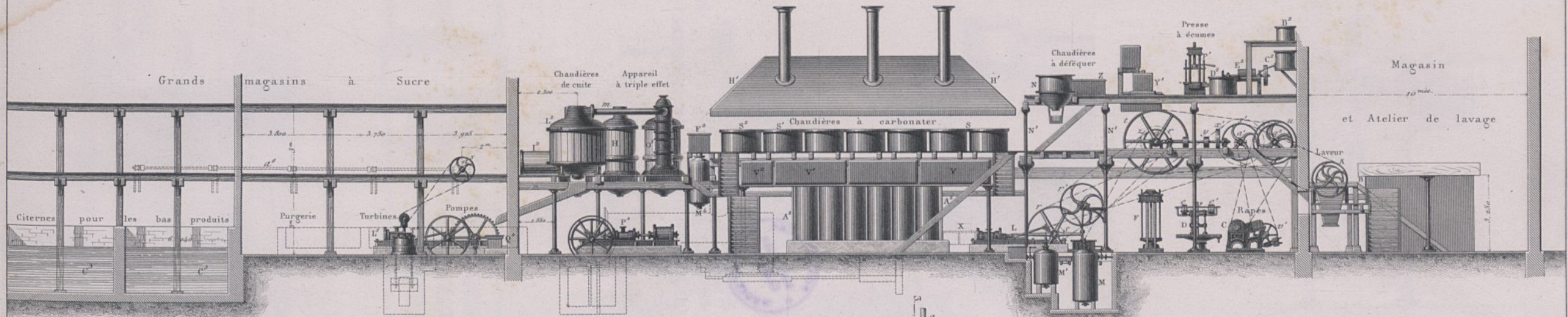
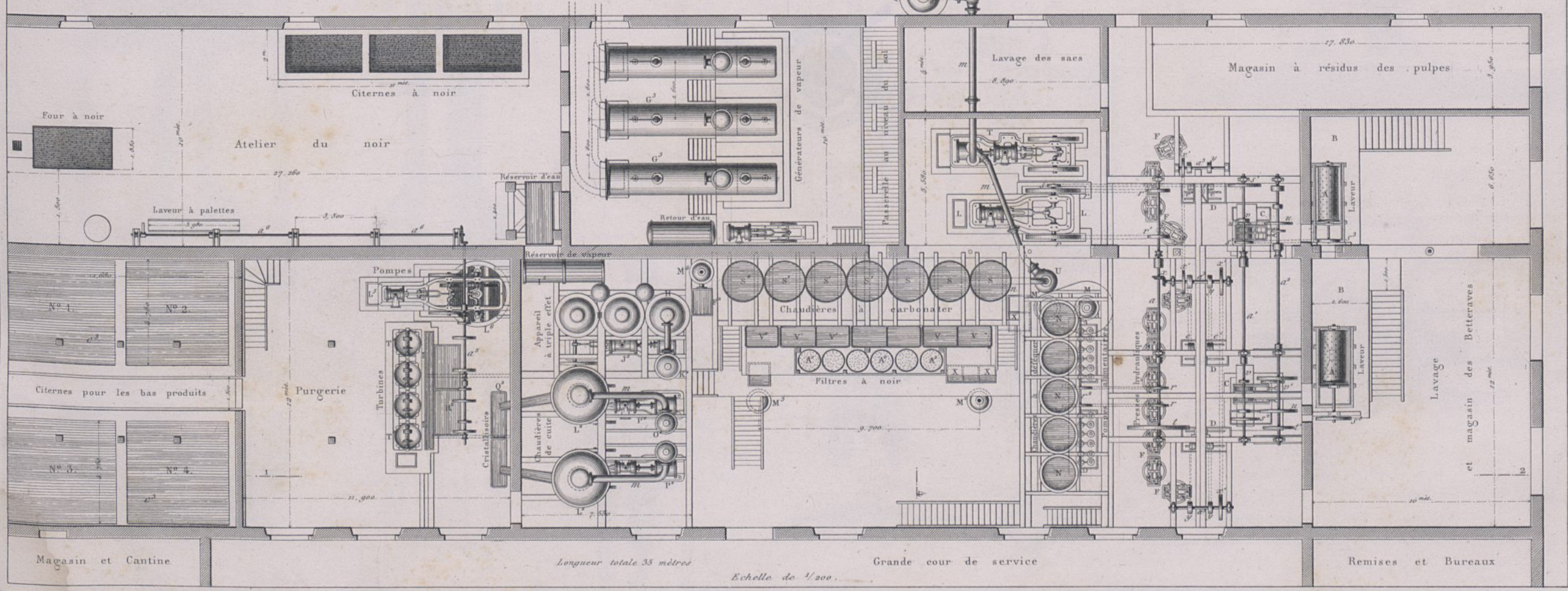
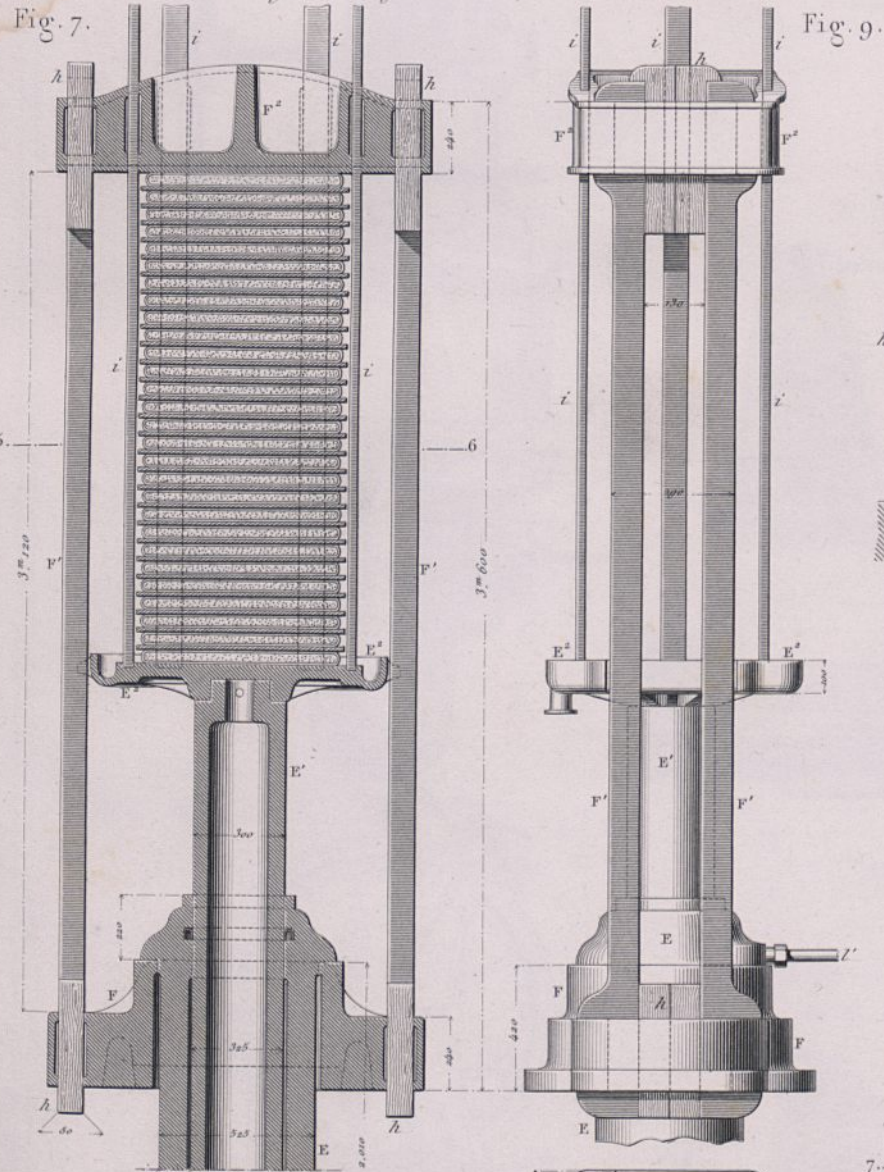


Fig. 1. Plan général des machines et appareils.

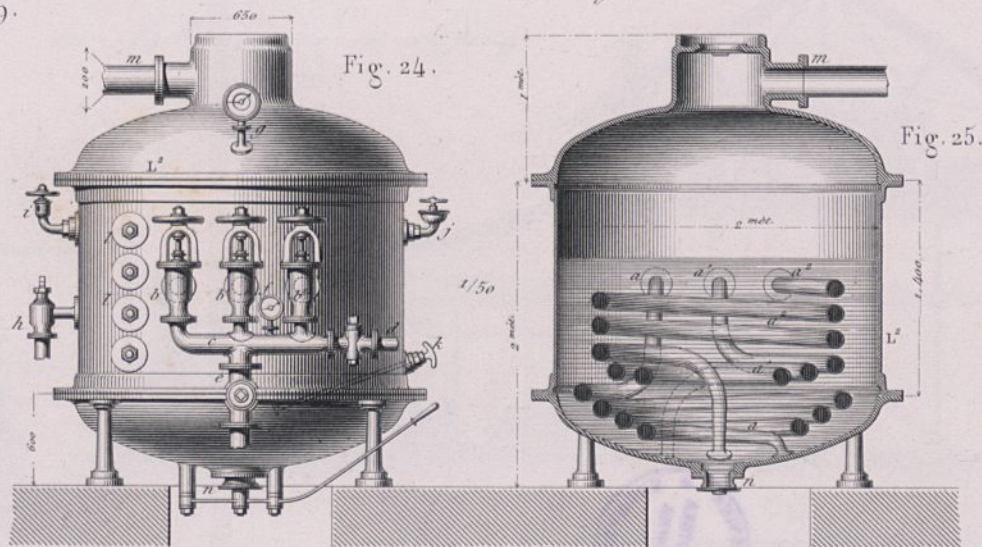




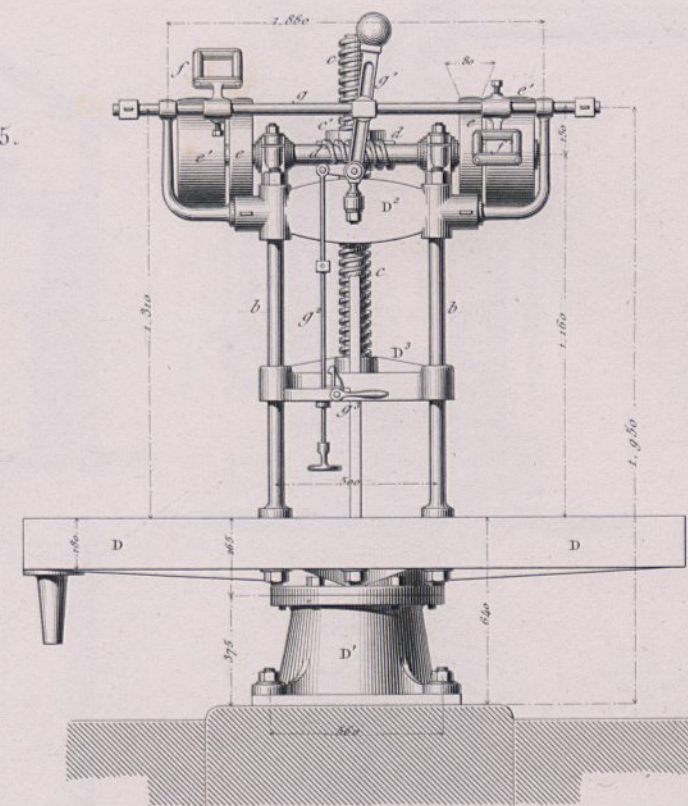
Presse hydraulique.



Chaudière de cuisson en grains.



Presse à vis.



Monte-jus.

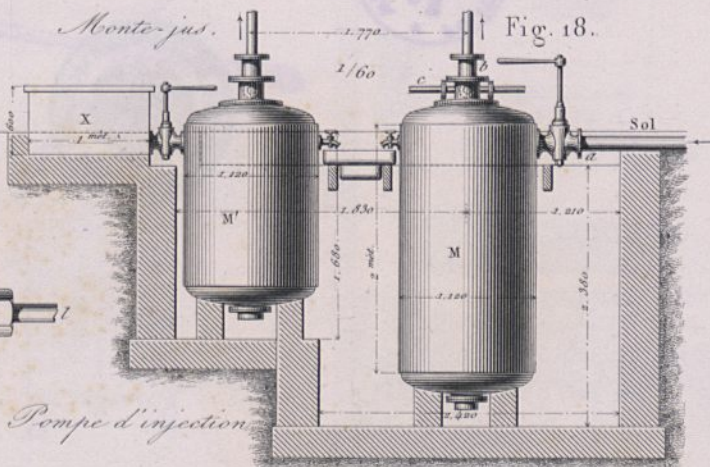
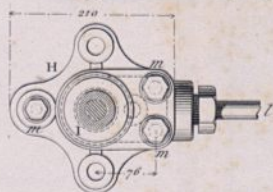
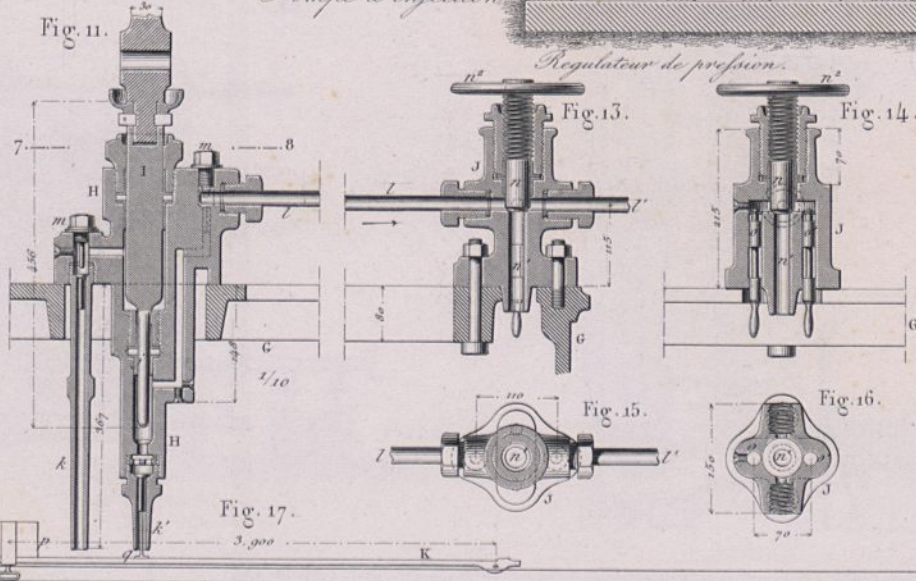


Fig. 12.

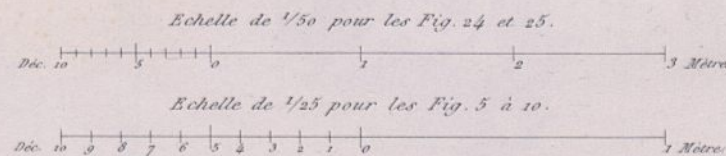
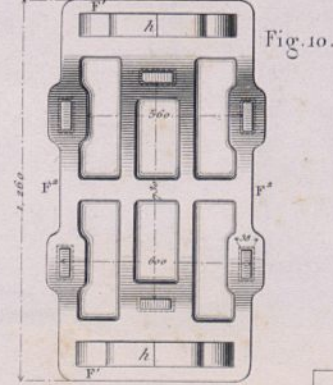
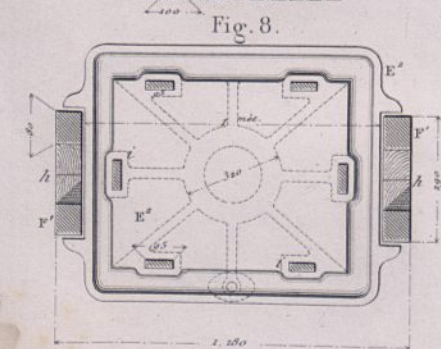
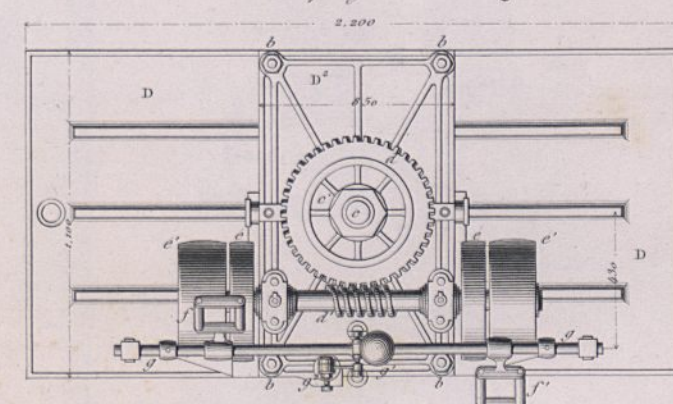


Pompe d'injection



Régulateur de pression.

Table de presse.





Ensemble du Procédé de carbonatation de M. Perier et Popsz.

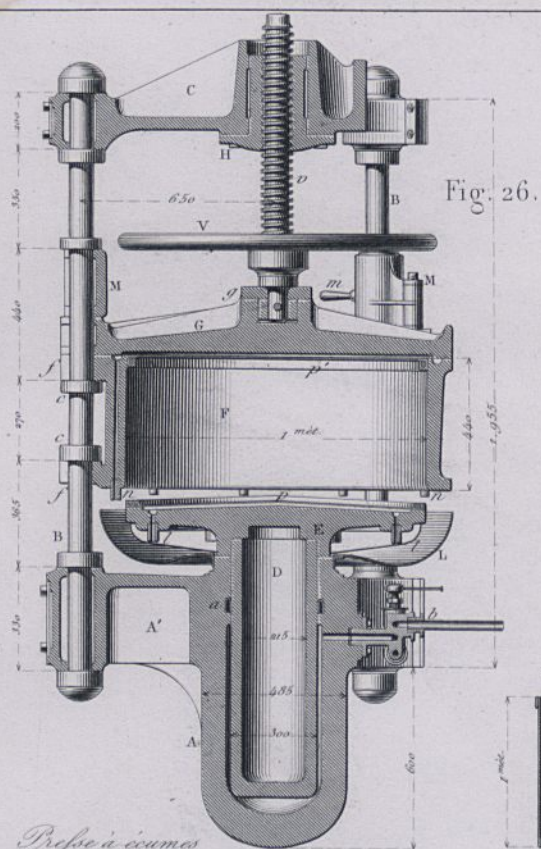


Fig. 26.

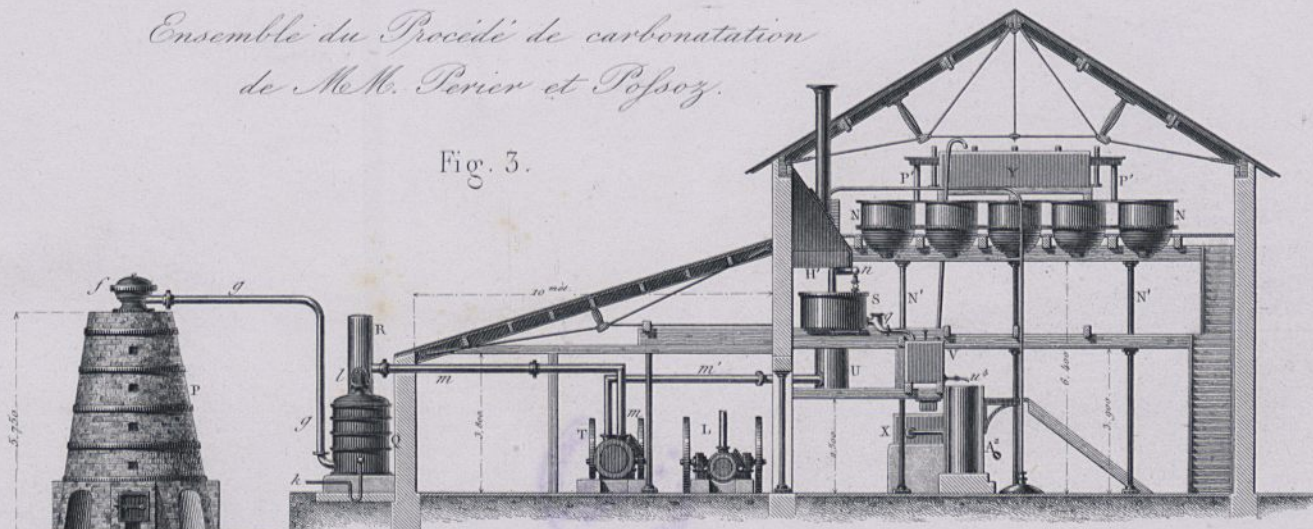


Fig. 3.

Echelle de 1/200

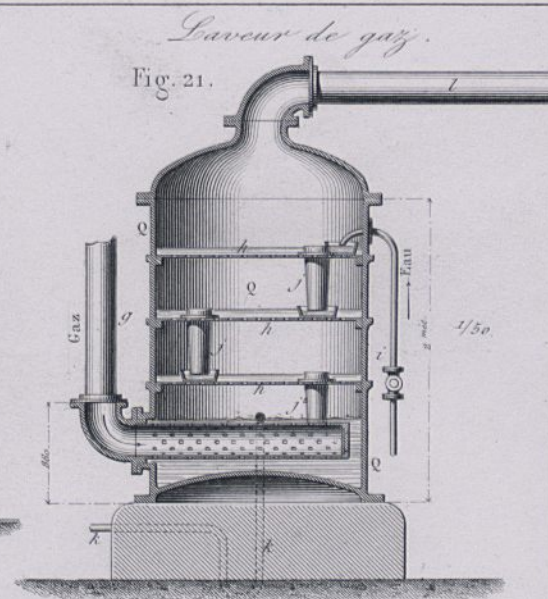


Fig. 21.

Laveuse de gaz.

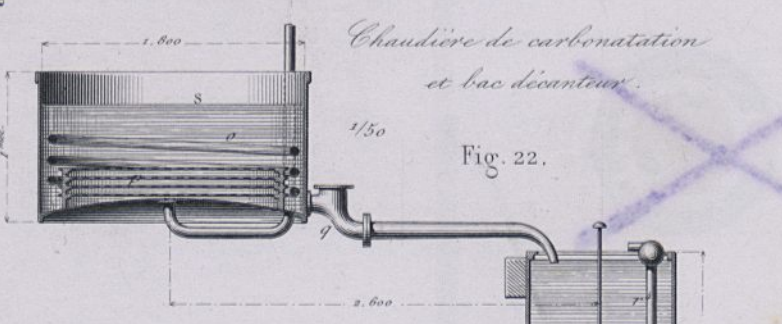


Fig. 22.

Chaudière de carbonatation et bac dévanteur.

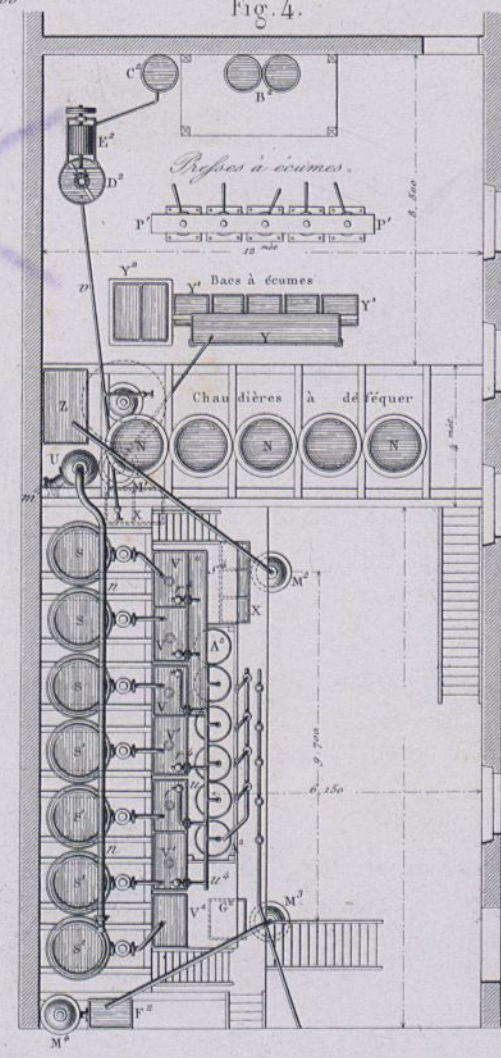


Fig. 4.

Prepes à écumes.

Bacs à écumes.

Chaudières à dégréger.

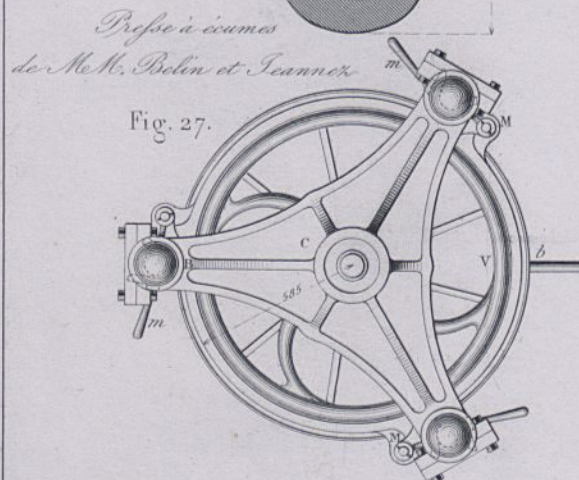


Fig. 27.

Echelle de 1/25.

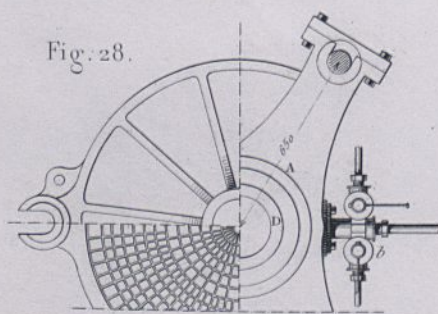


Fig. 28.

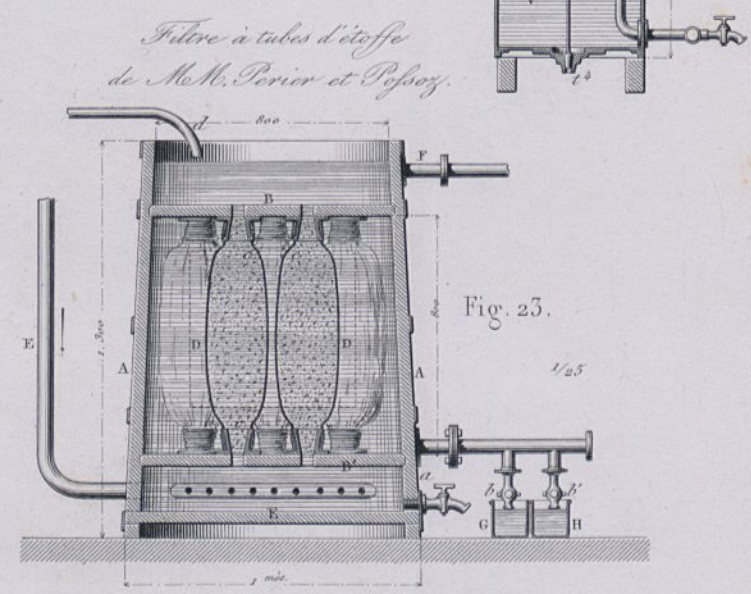


Fig. 23.

Filtre à tubes d'étoffe de M. Perier et Popsz.

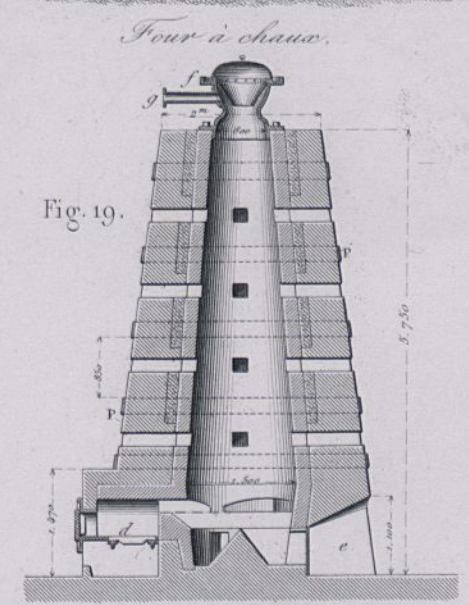


Fig. 19.

Four à chaux.

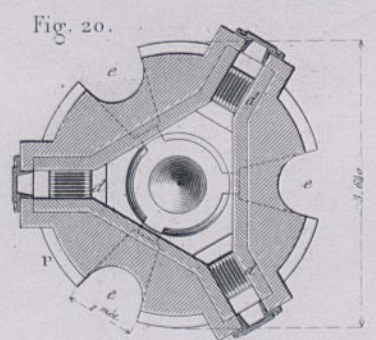


Fig. 20.

Echelle de 1/100.



Fig. 3.

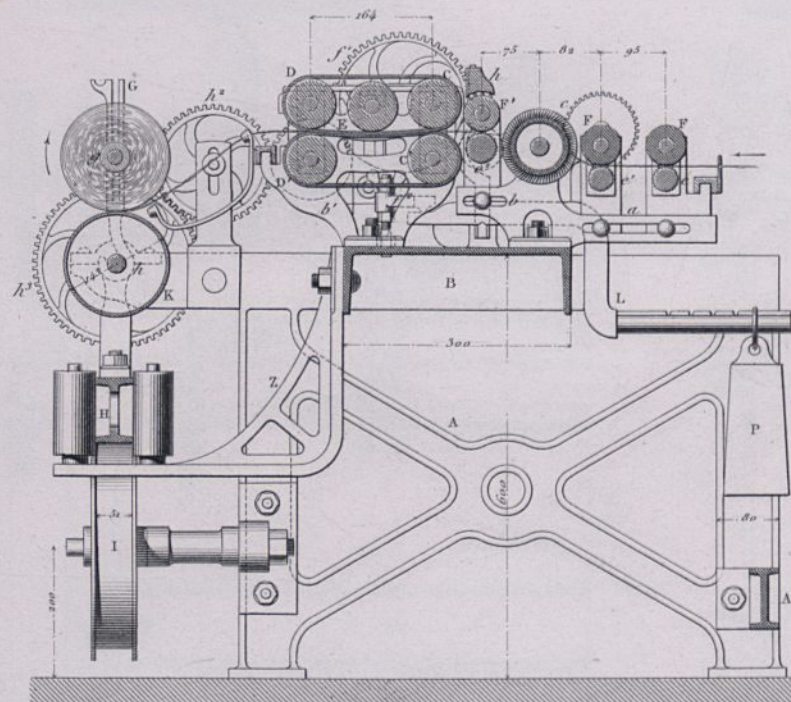


Fig. 4.

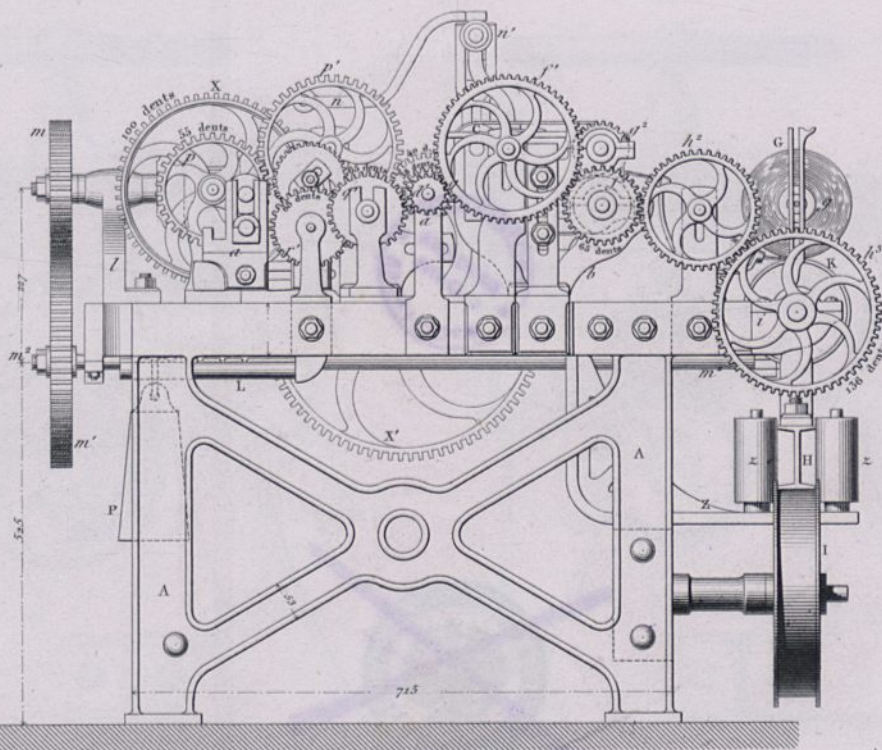
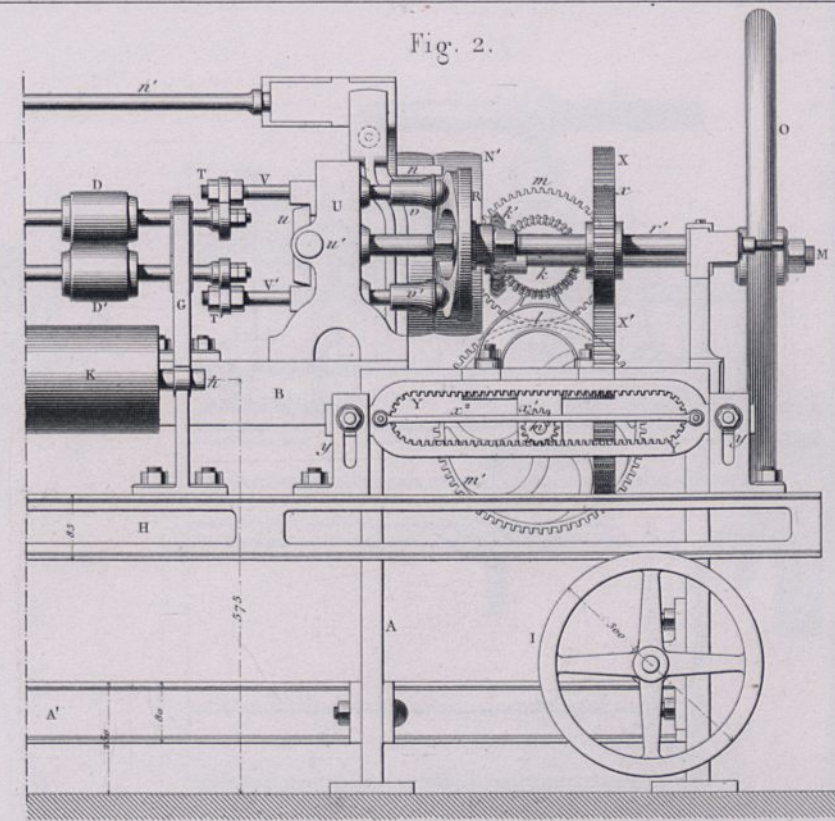


Fig. 2.



Echelle de 1/10.

Fig. 1.

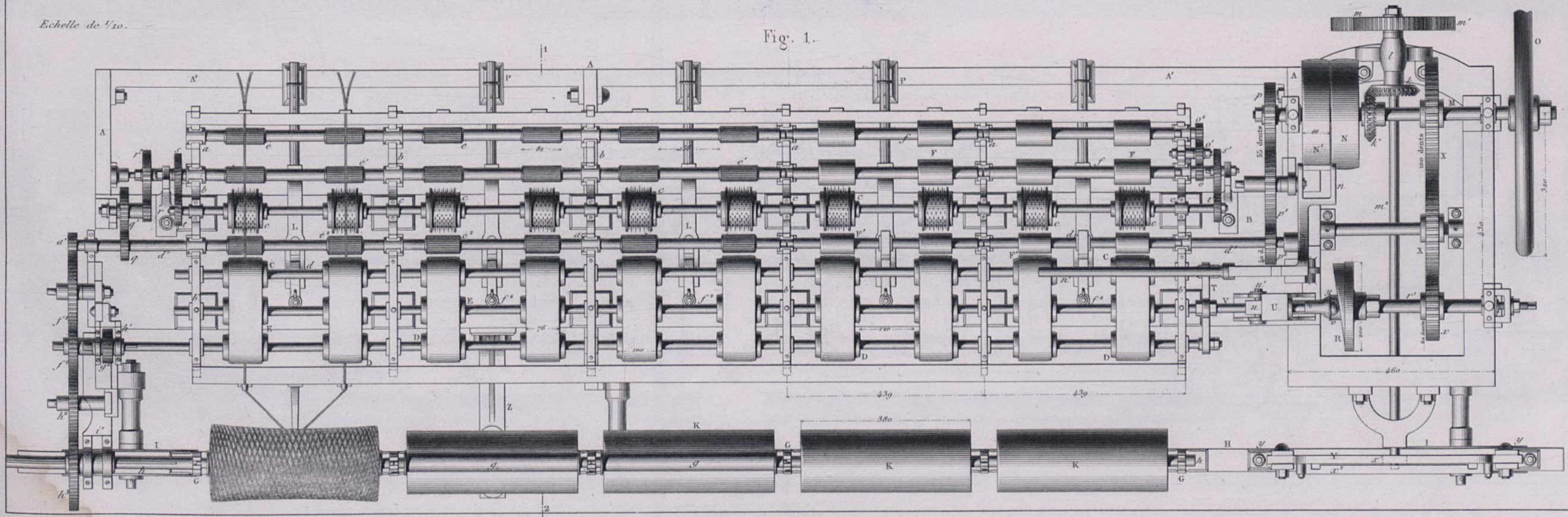




Fig. 2.

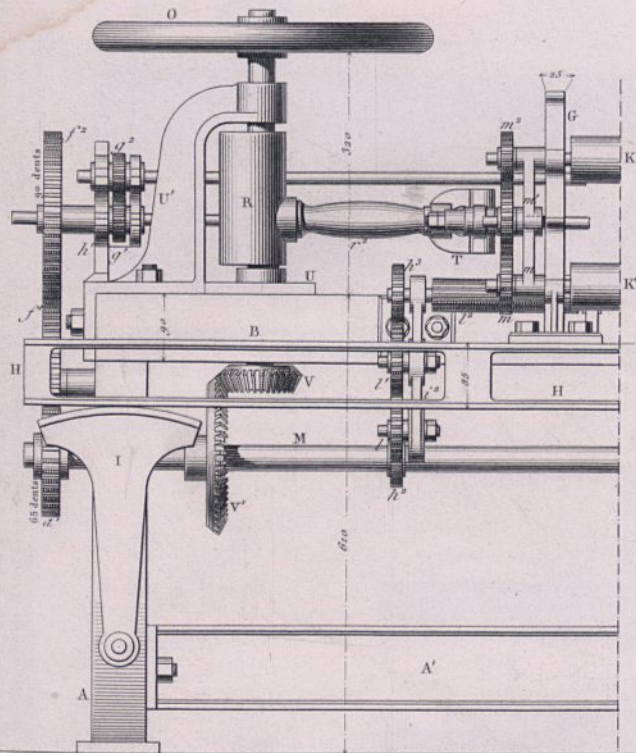


Fig. 4.

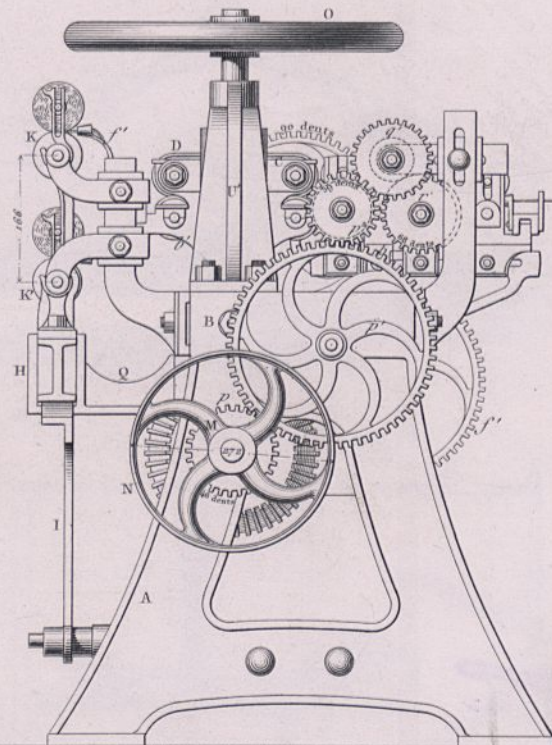


Fig. 5.

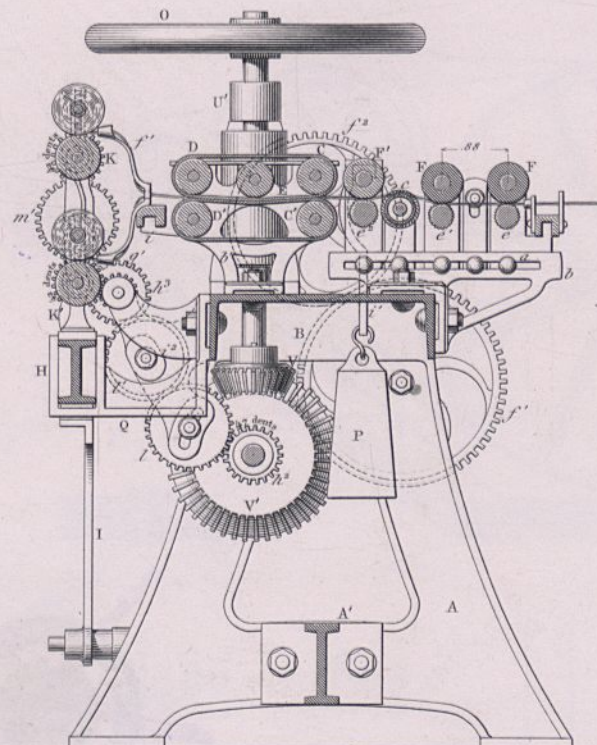


Fig. 3.

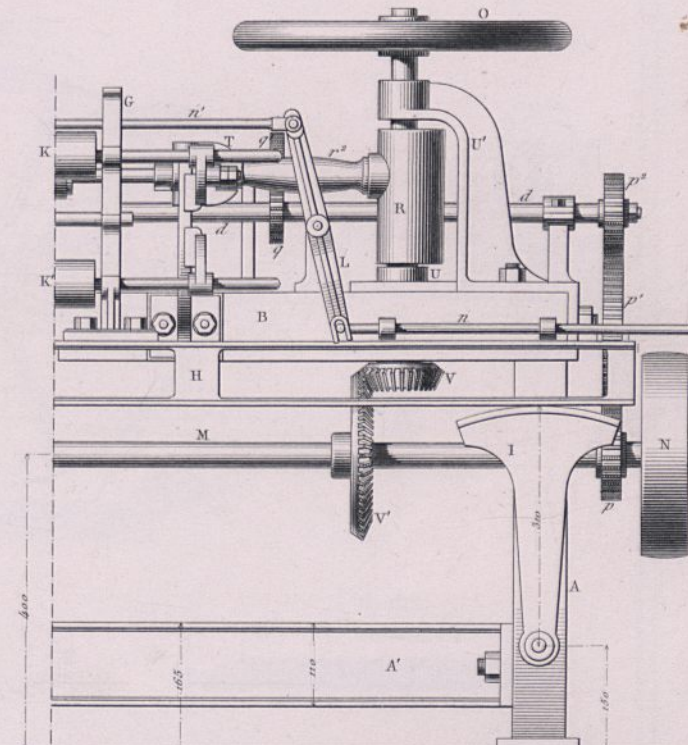
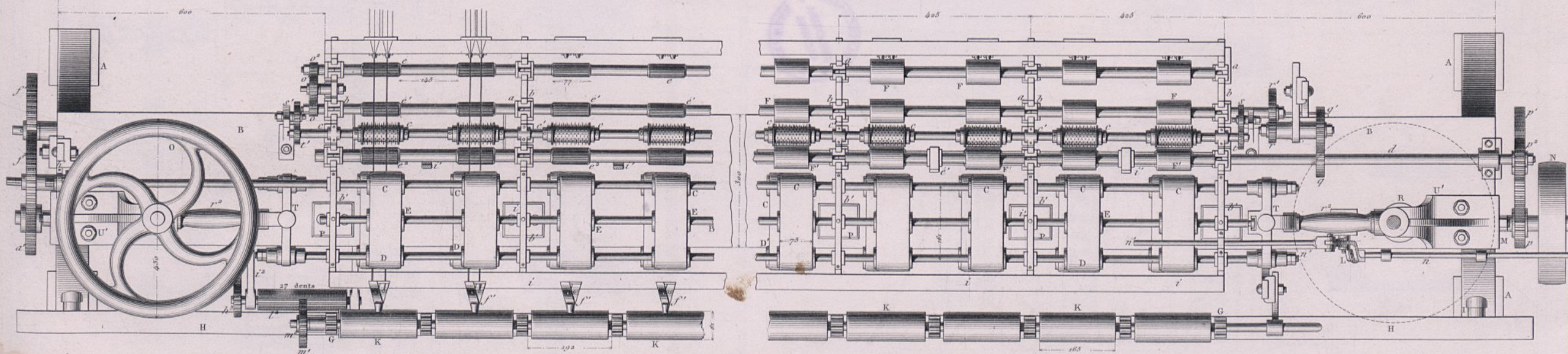


Fig. 1.

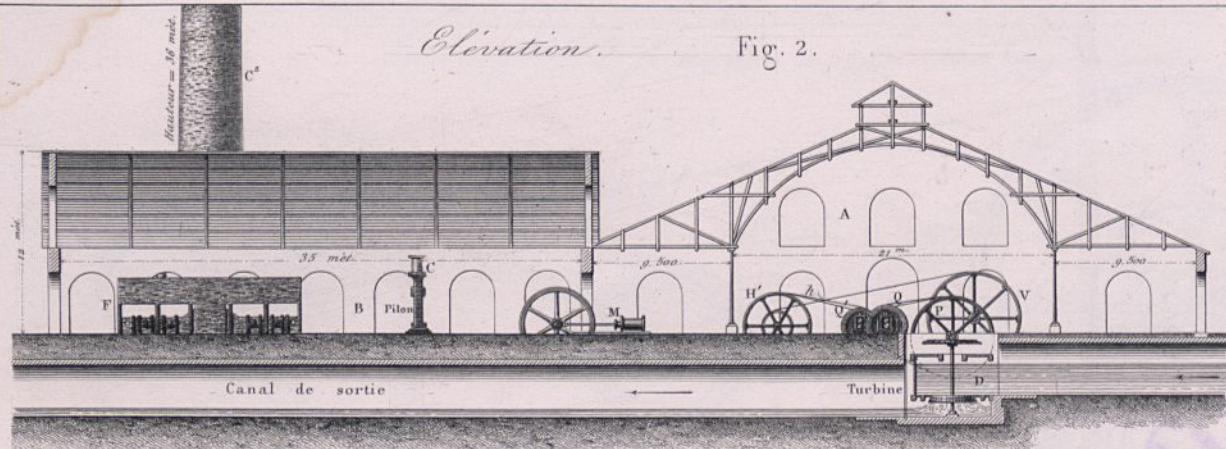
Longueur totale = 8^m 350 pour 36 peignes et 72 bobines.



Echelle de 1/10.

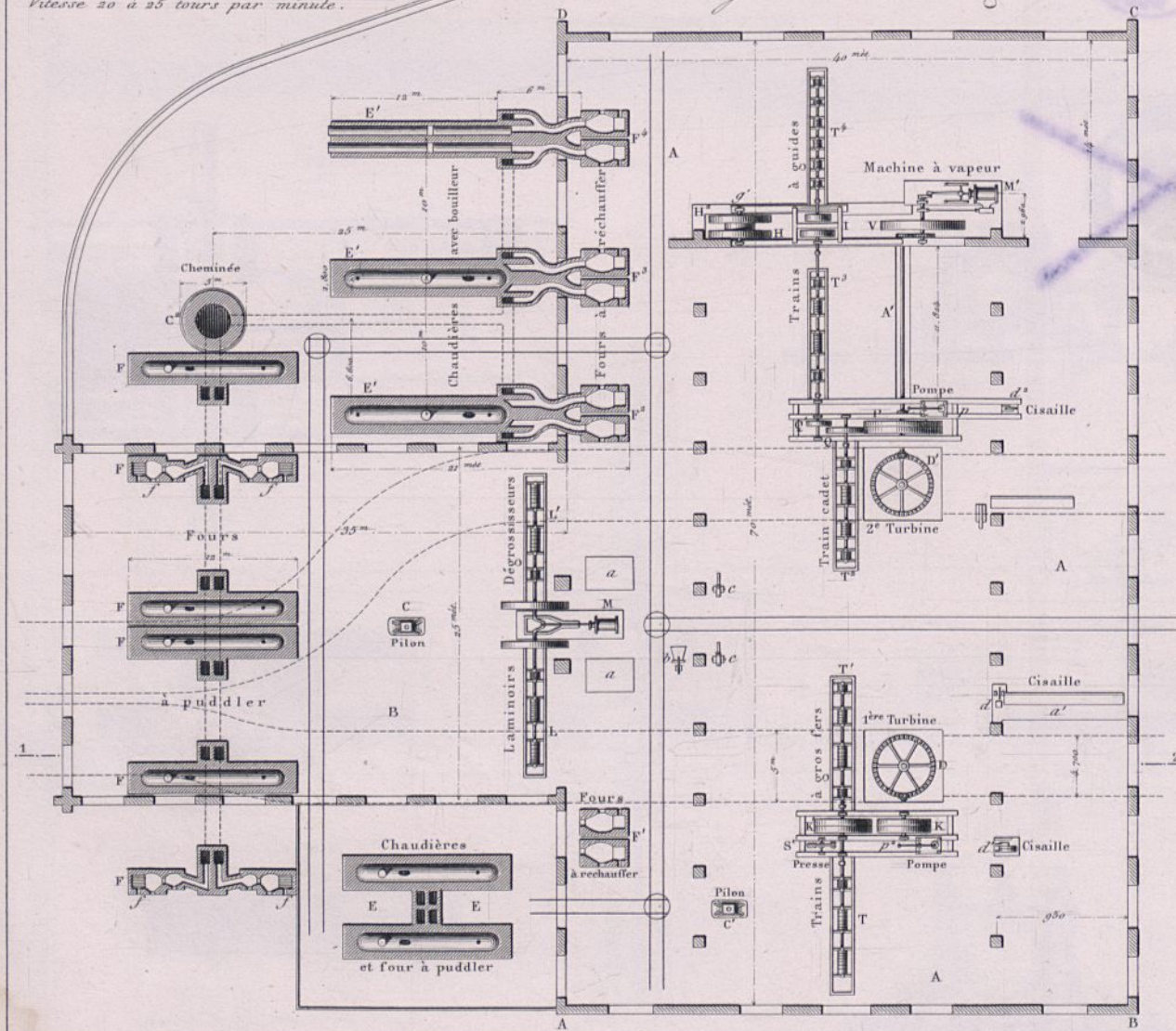


Elevation. Fig. 2.



La force motrice de chaque turbine est de 90 à 100 chevaux.
 La hauteur de la chute de 2 à 3 mètres 50.
 Vitesse 20 à 25 tours par minute.

Plan général. Fig. 1.



Transmission par poulies et courroies de la 2^e turbine au train cadet et au train à guides. Fig. 3.

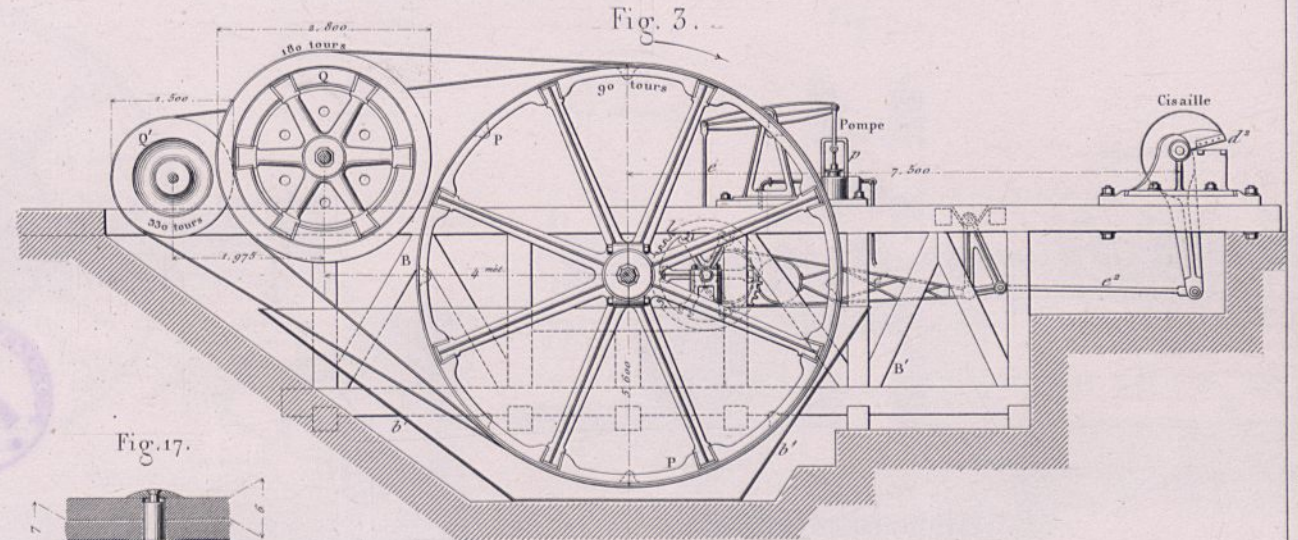
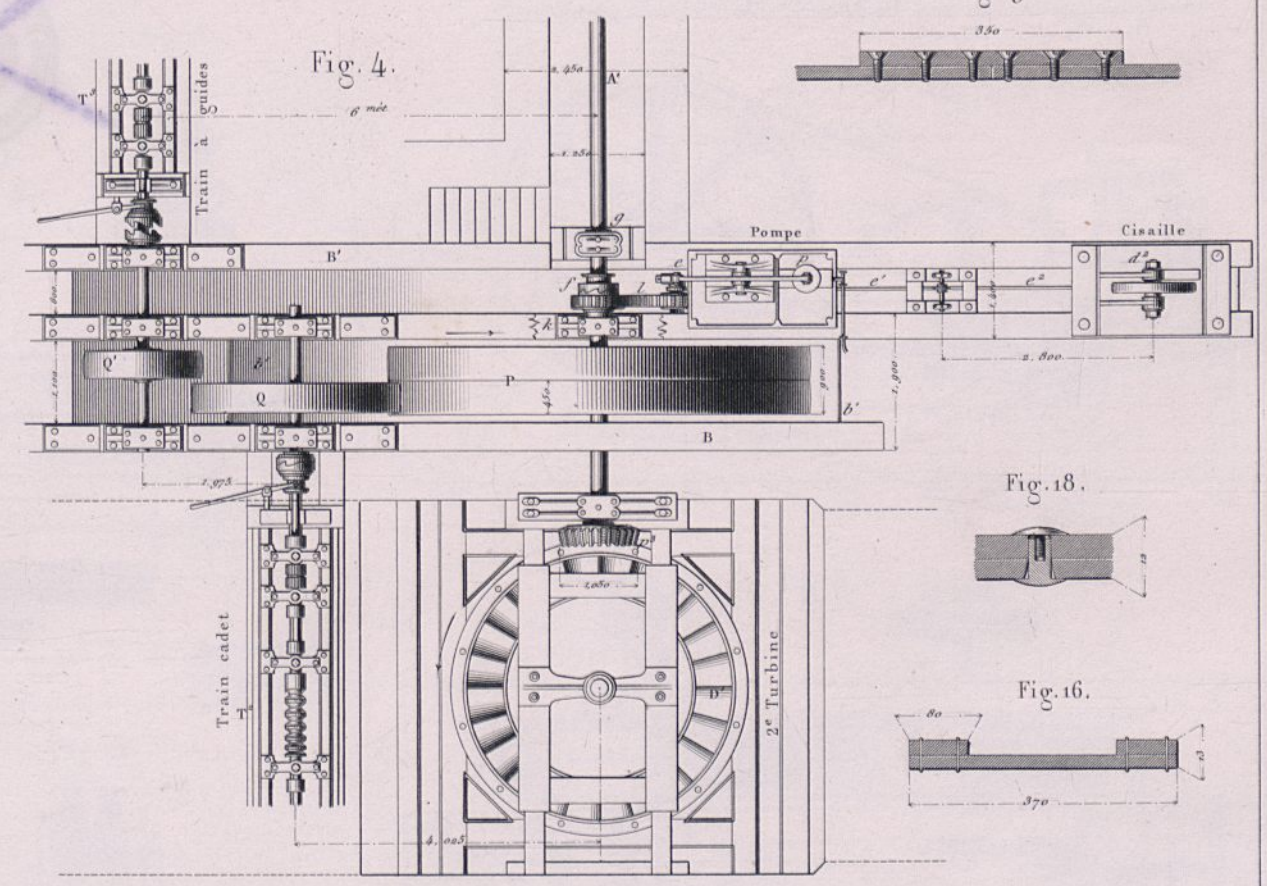


Fig. 17.



Fig. 4.



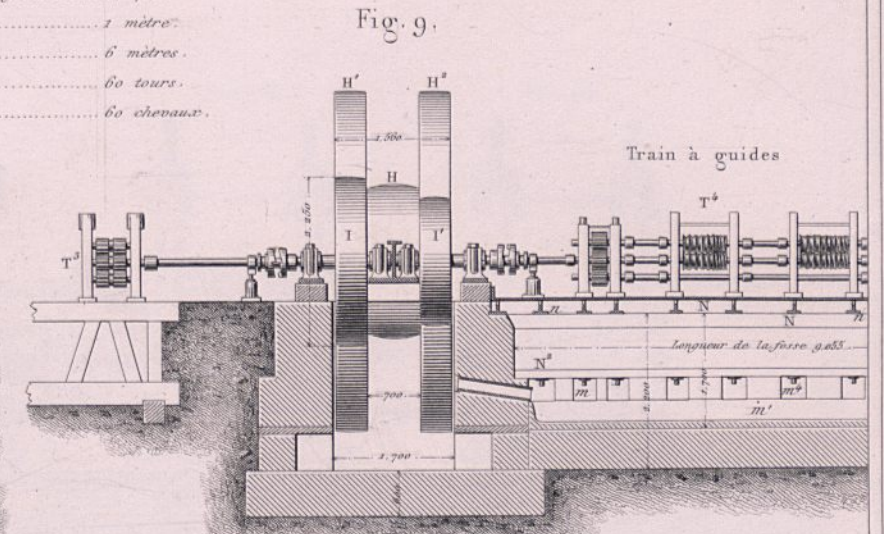
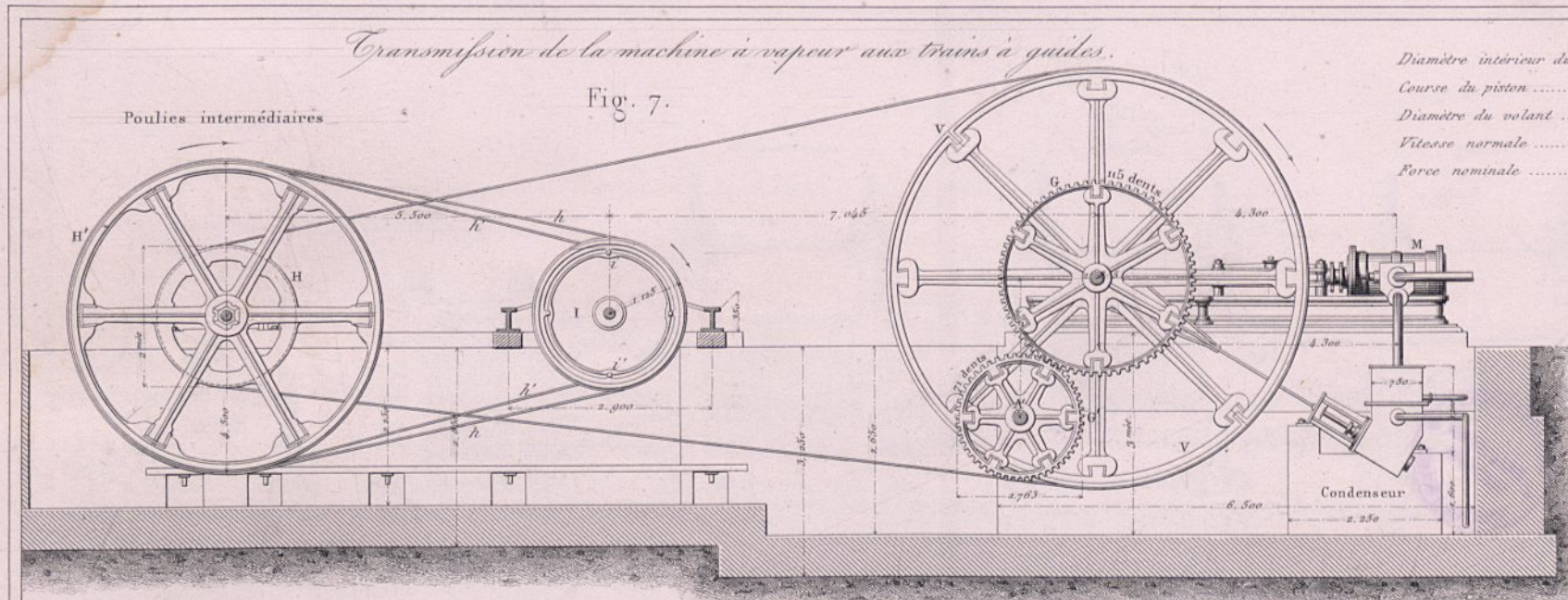
Echelle de 1/500 pour les Fig. 1 et 2.

Echelle de 1/100 pour les Fig. 3 et 4.

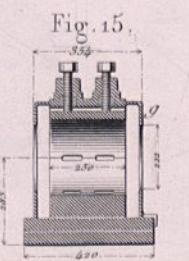
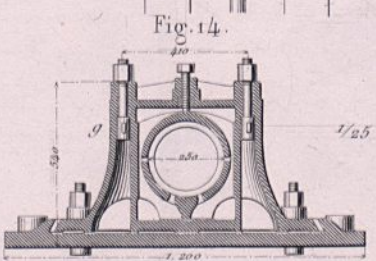
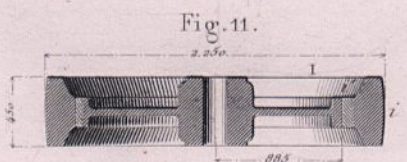
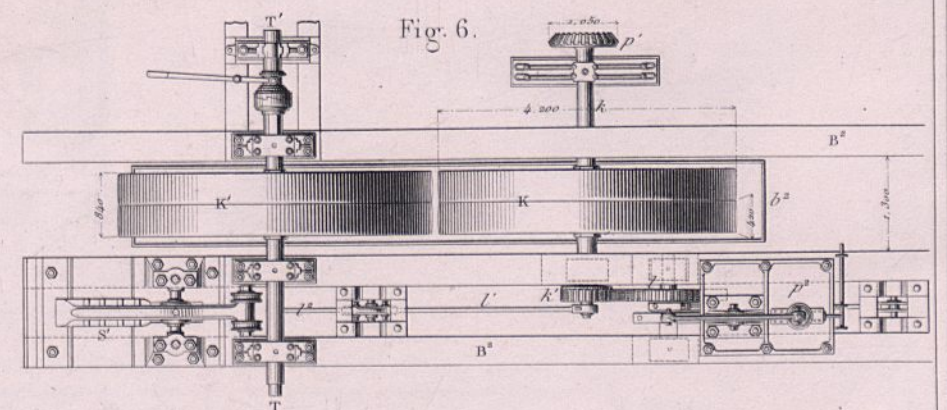
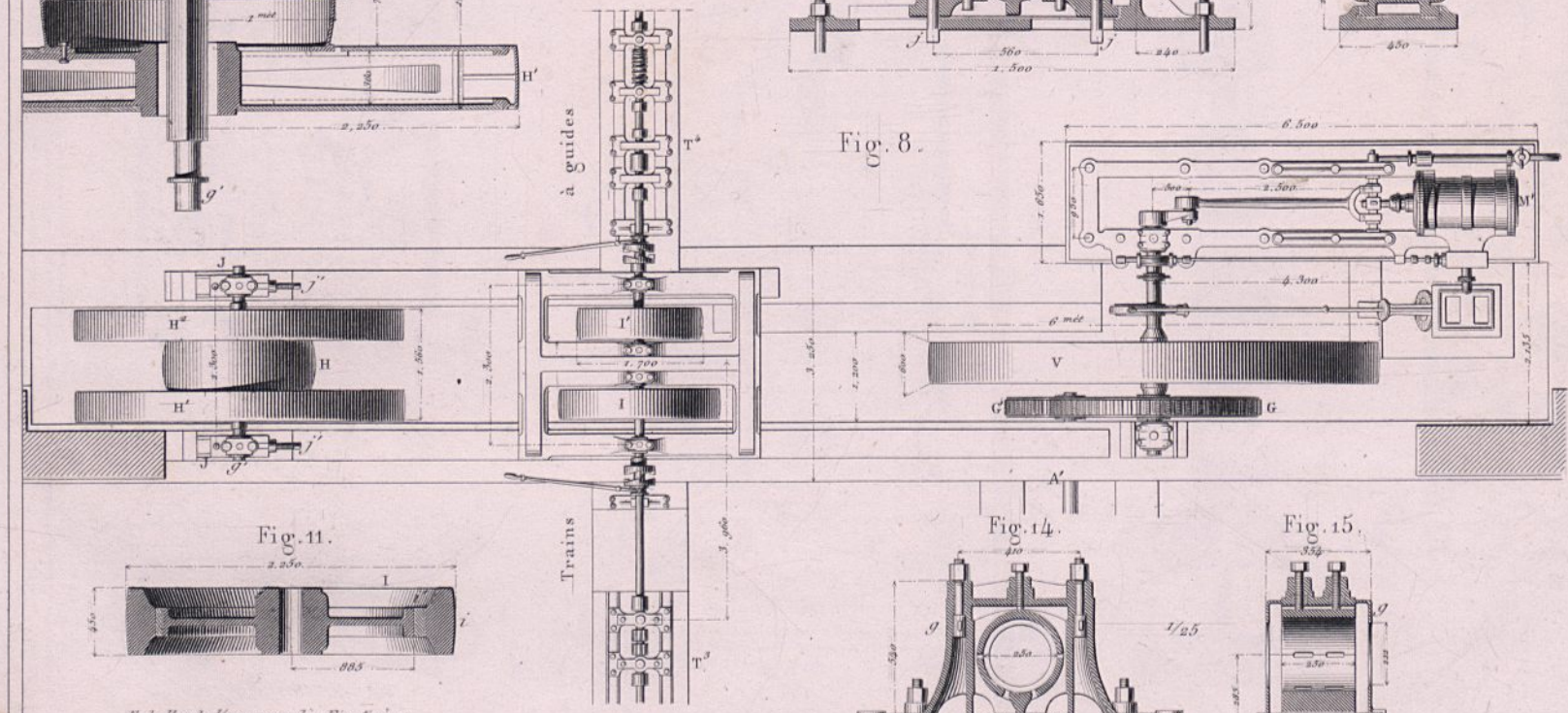
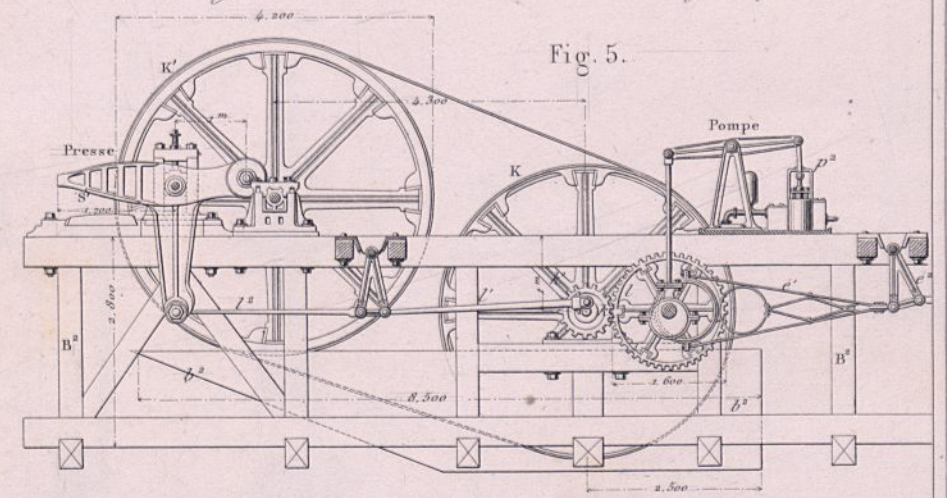
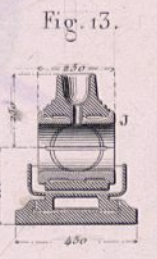
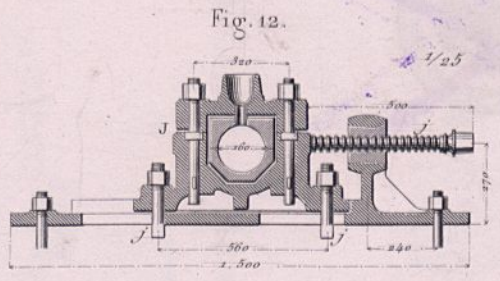
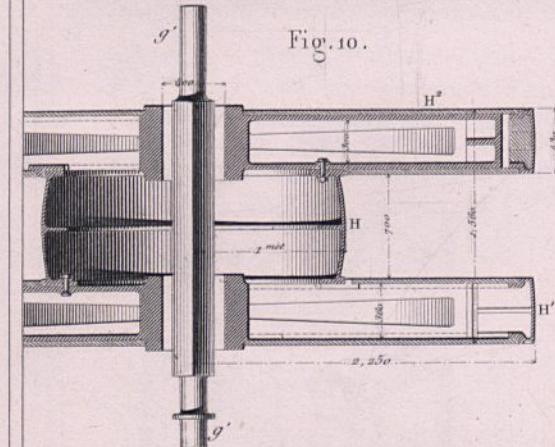


Transmission de la machine à vapeur aux trains à guides.

Diamètre intérieur du cylindre 0.^m 700.
Course du piston 1 mètre.
Diamètre du volant 6 mètres.
Vitesse normale 60 tours.
Force nominale 60 chevaux.



Transmission de la T. turbine aux trains à gros fers.



Echelle de 1/100 pour les Fig. 5 à 9.
Echelle de 1/50 pour les Fig. 10 et 11.



Fig. 1.

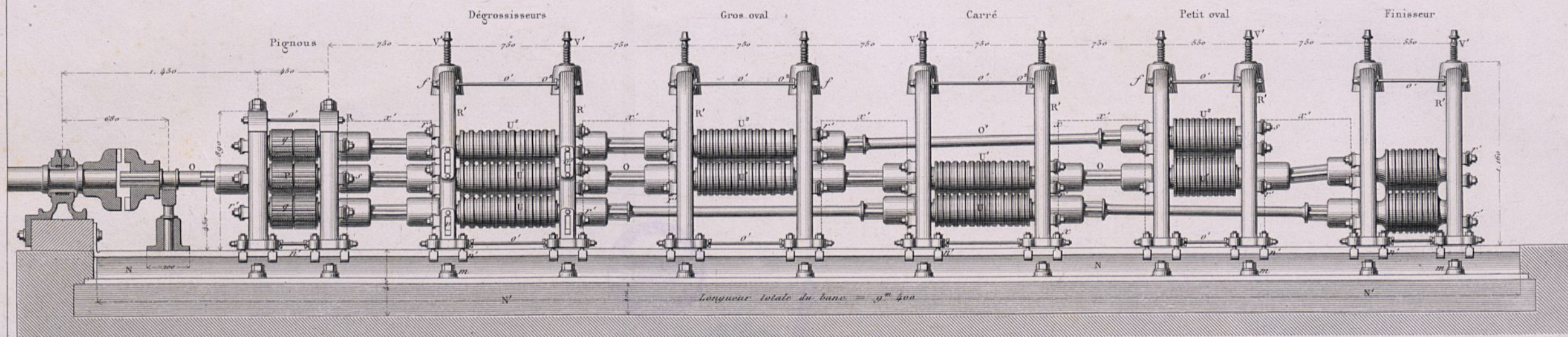


Fig. 2.

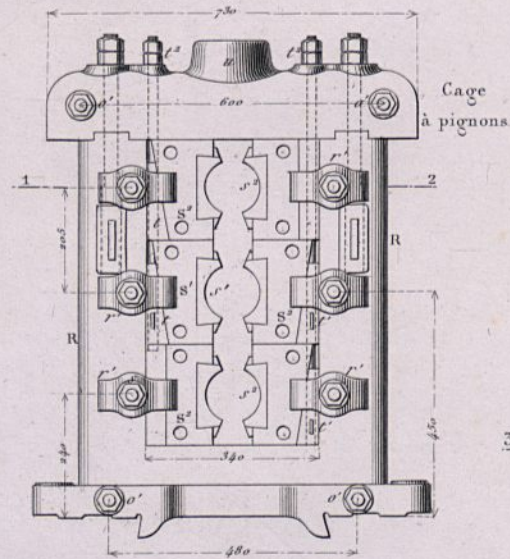


Fig. 4.

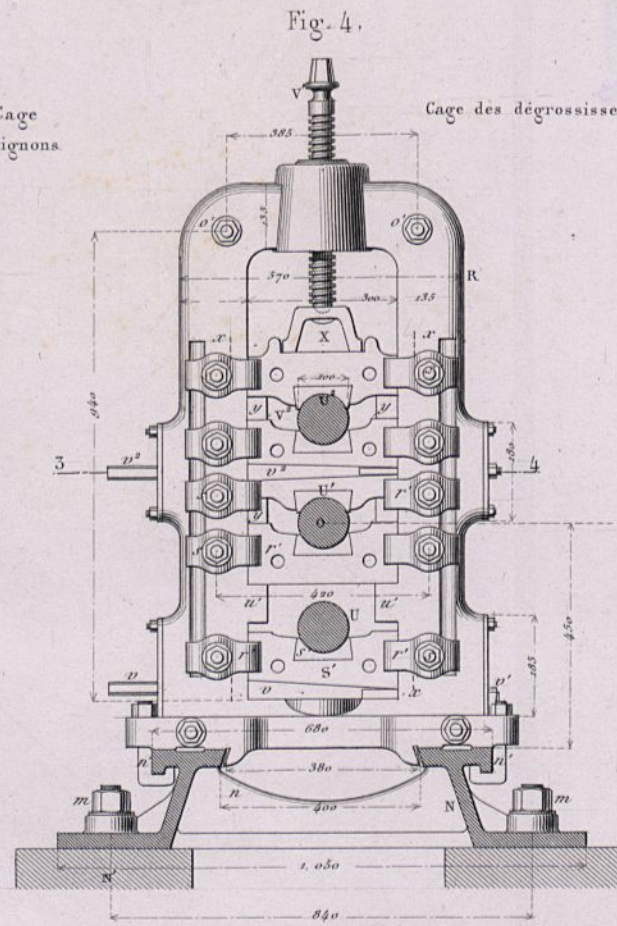


Fig. 5.

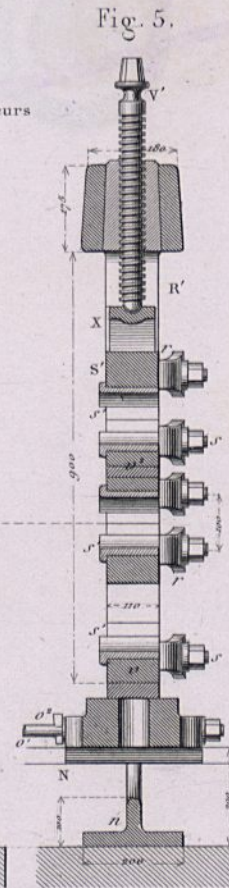


Fig. 6.

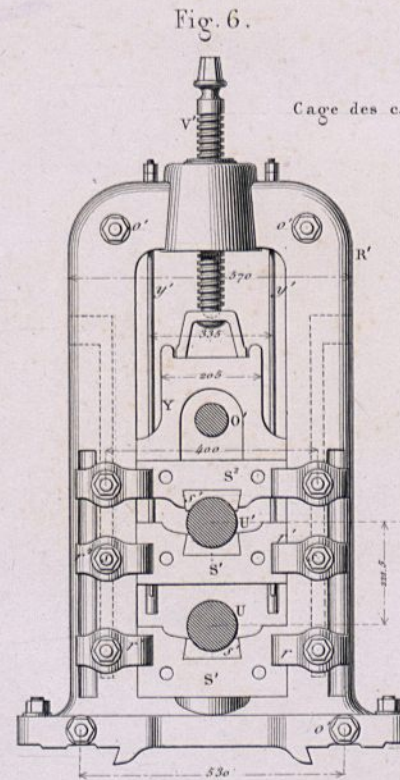


Fig. 7.

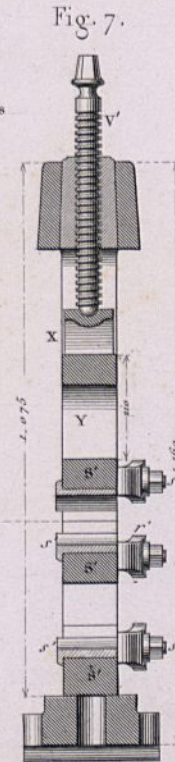


Fig. 8.

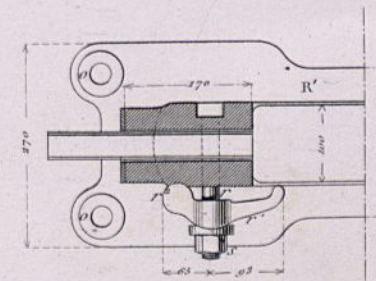


Fig. 3.

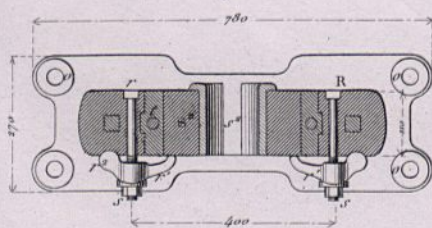
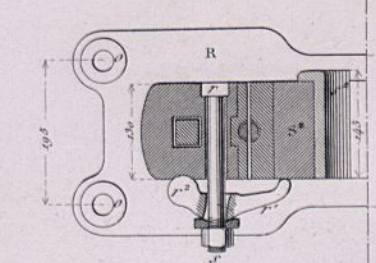


Fig. 9.



Echelle de 1/10.

Echelle de 1/30 pour la Fig. 1.

0 1 2 3 4 5 6 7 8 9 10 2 Mètres.

Echelle de 1/15 pour les Fig. 2 à 7.

0 1 2 3 4 5 6 7 8 9 10 15 Décimètres.



Fig. 1.

Forges de Ruchecourt.

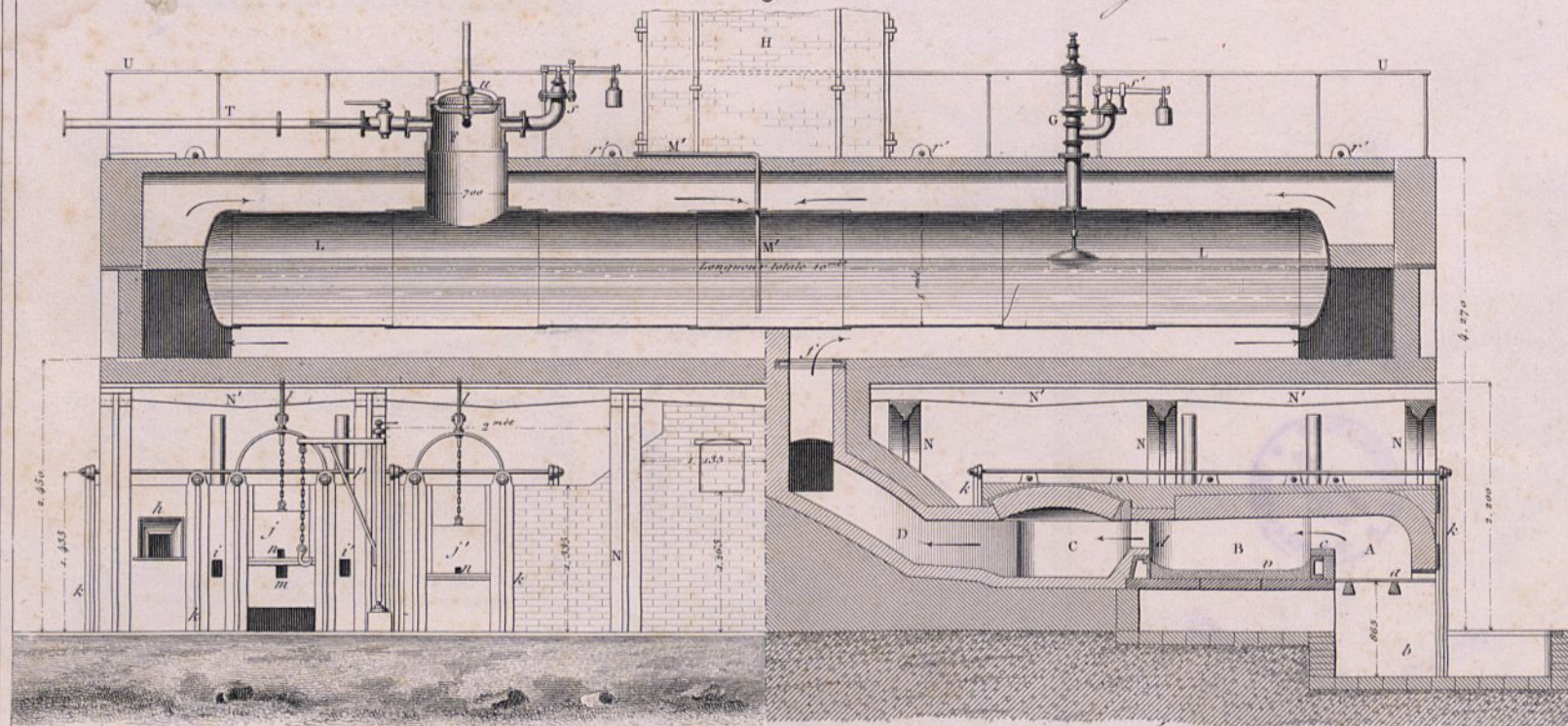


Fig. 3.

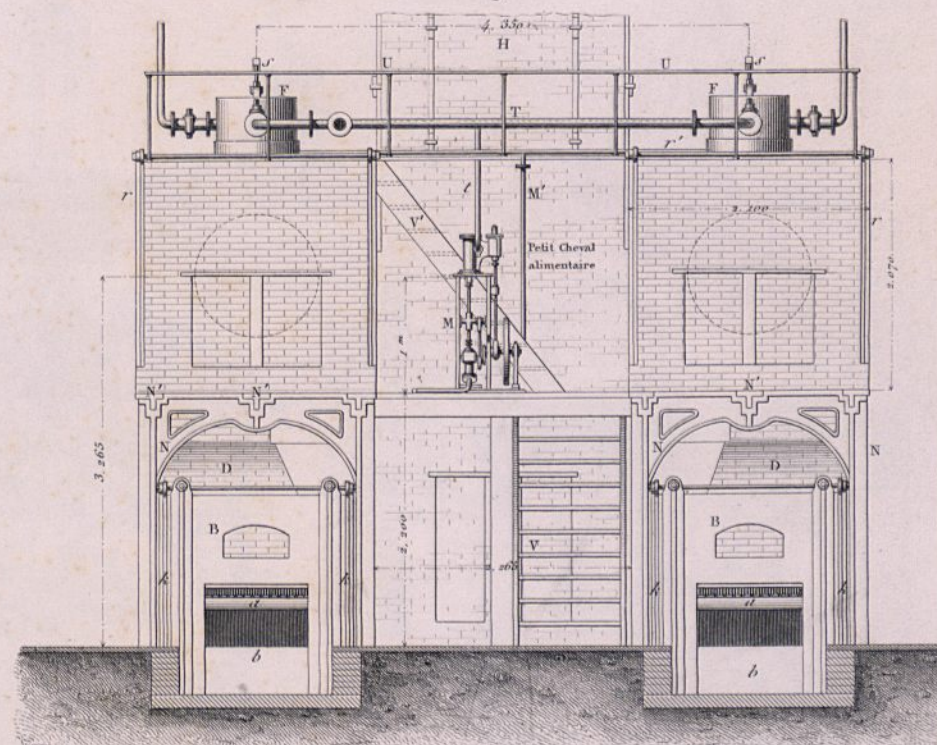


Fig. 2.

Longueur totale 12 mètres

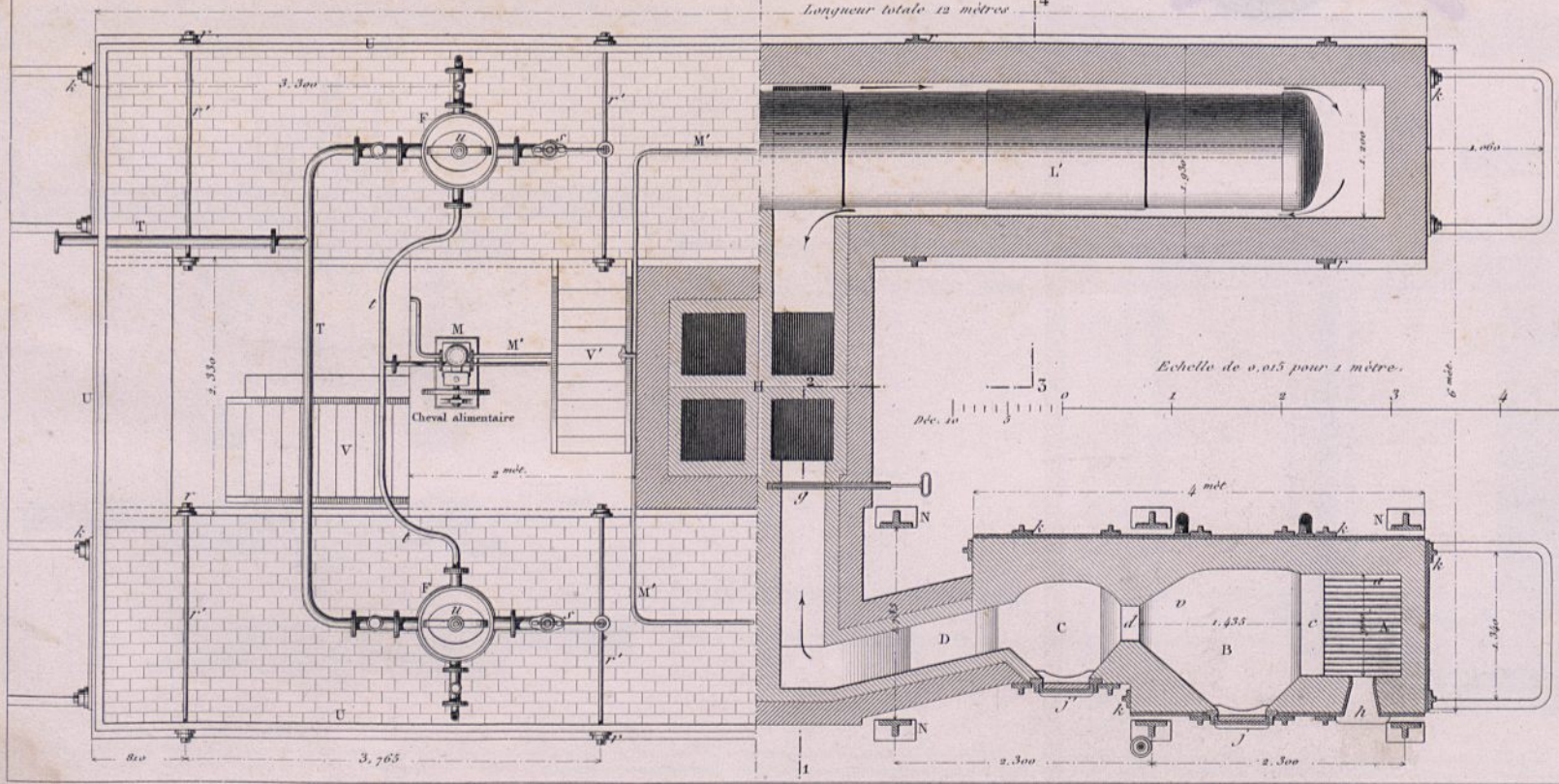
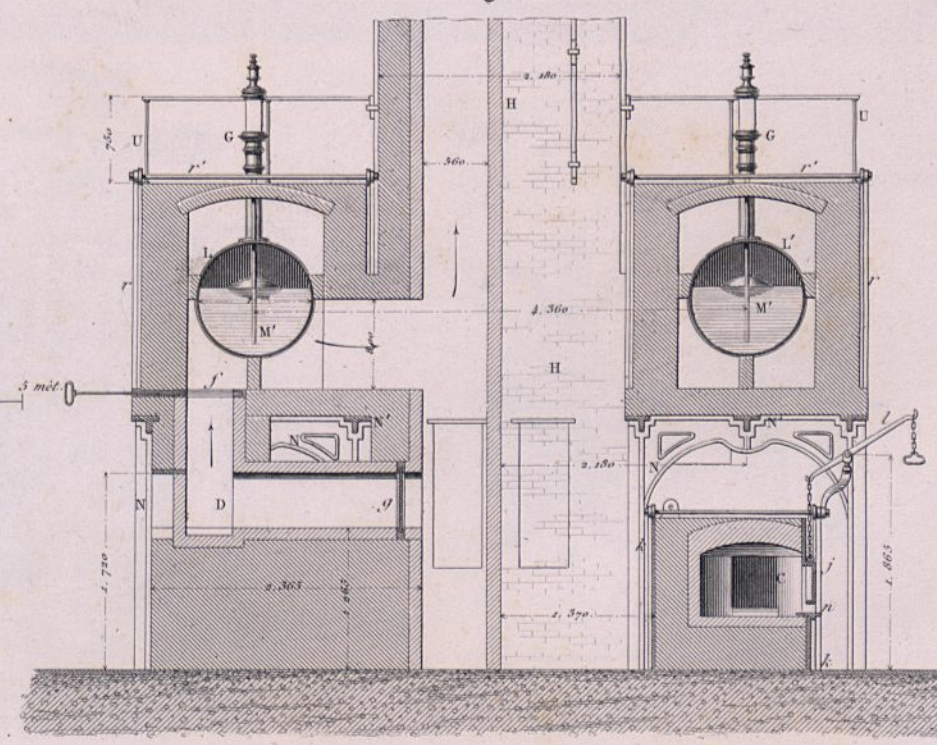


Fig. 4.





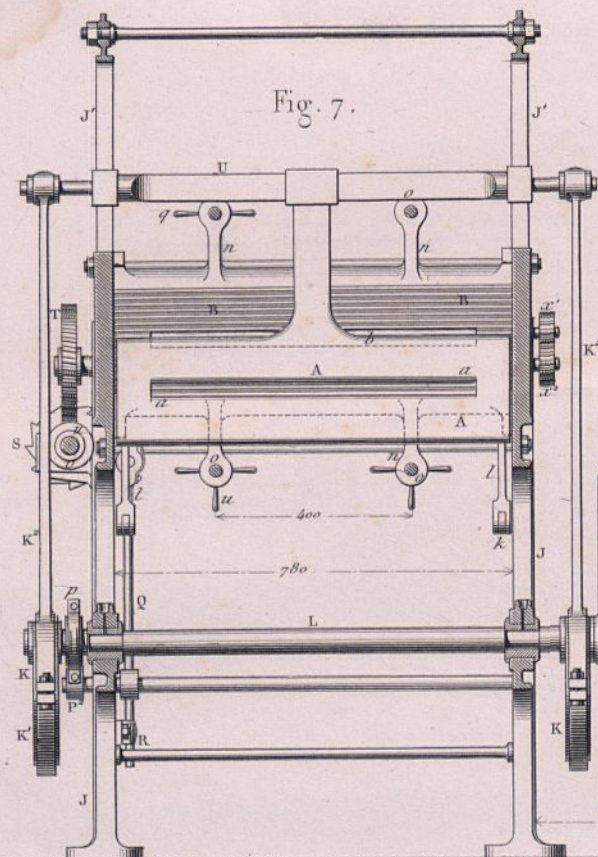


Fig. 7.

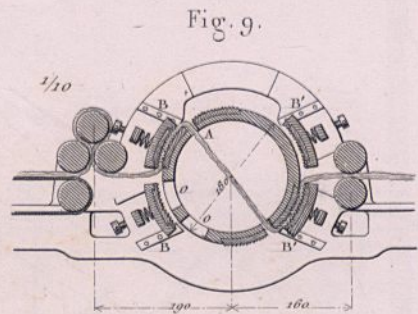


Fig. 9.

1/10

Fig. 8.

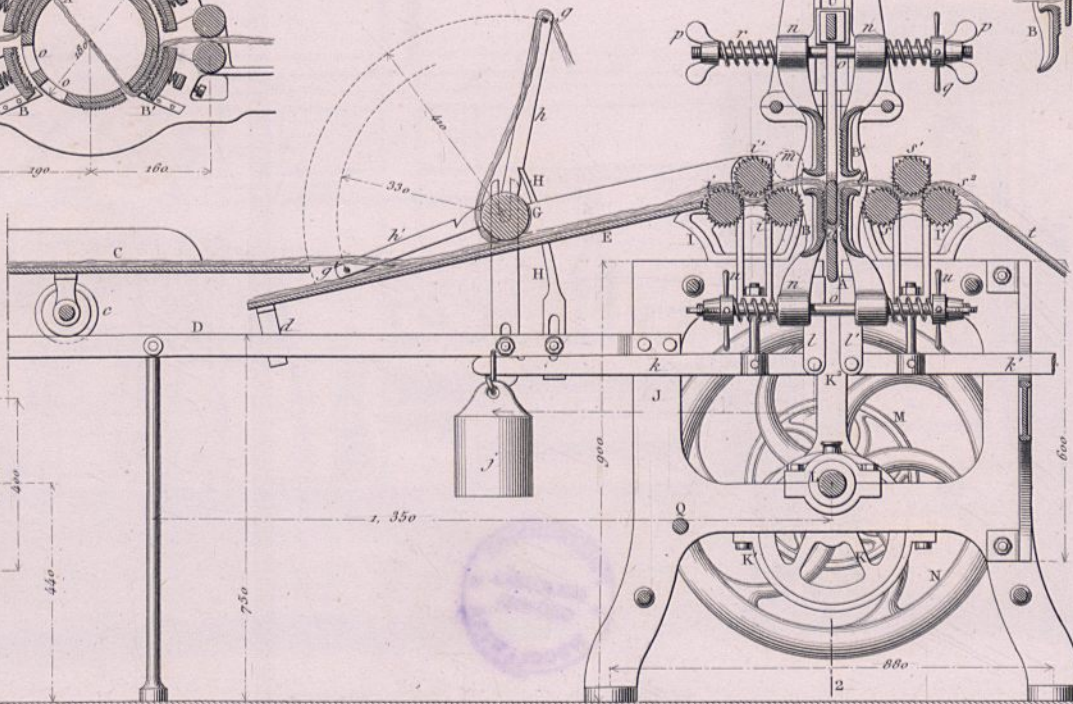


Fig. 4 bis



Fig. 6.

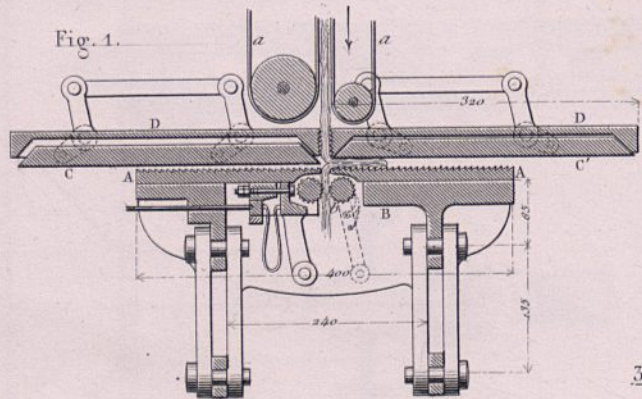
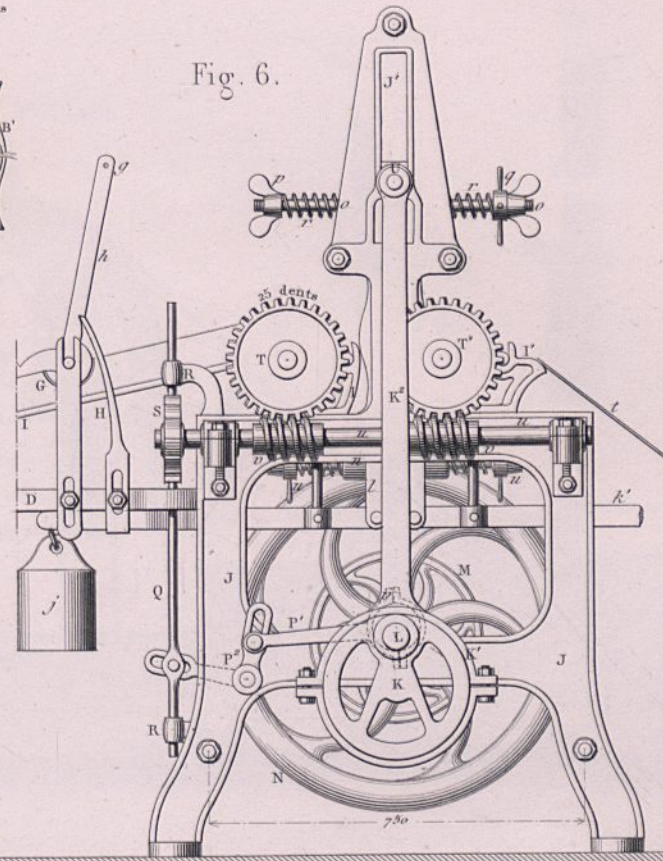


Fig. 1.

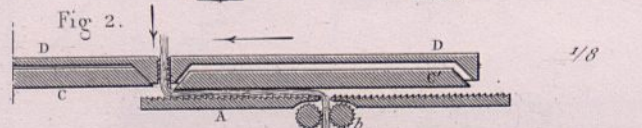


Fig. 2.

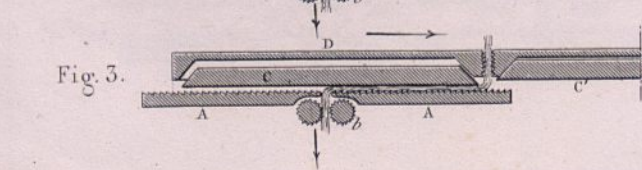


Fig. 3.

Fig. 5.

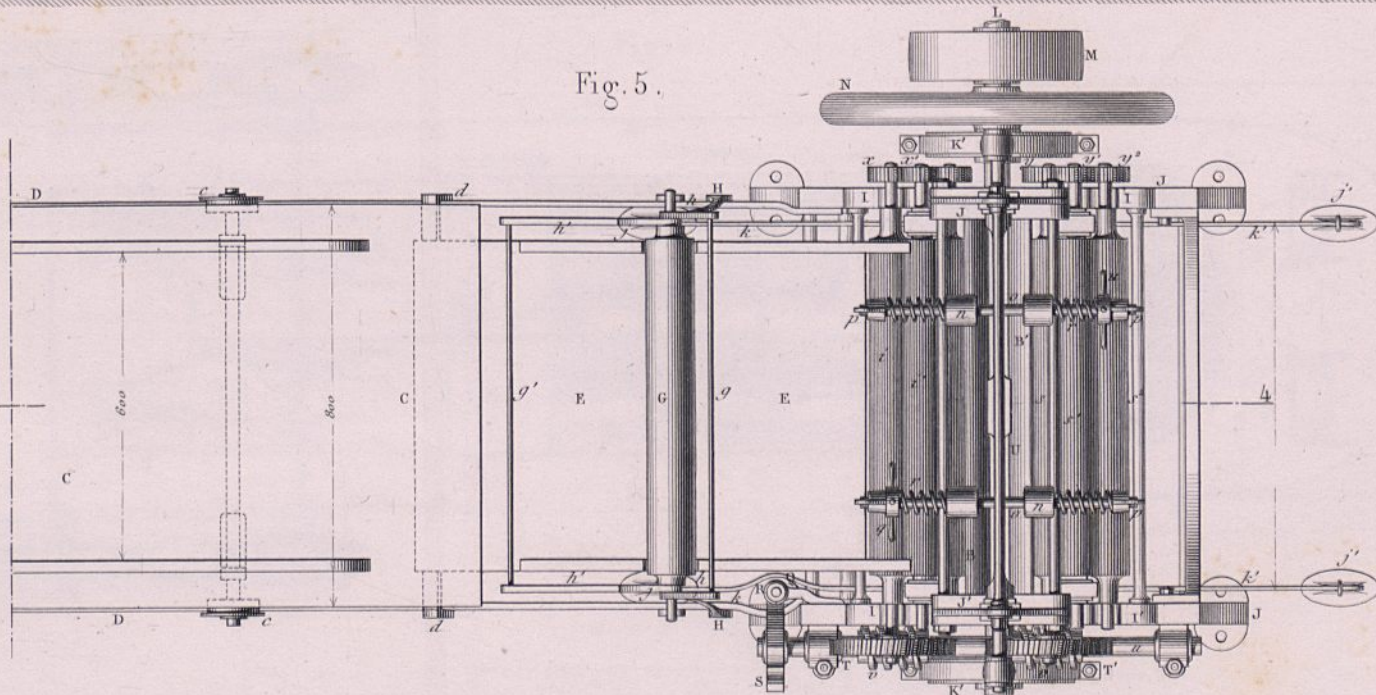
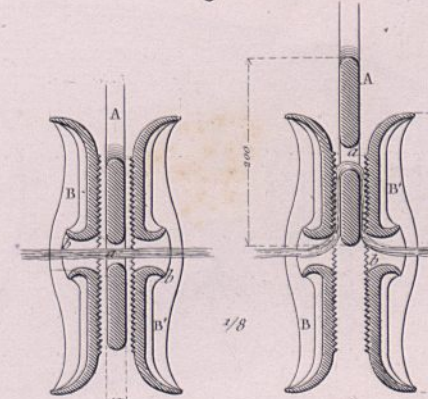


Fig. 4.



Echelle de 1/15 pour les Fig. 5 à 8.



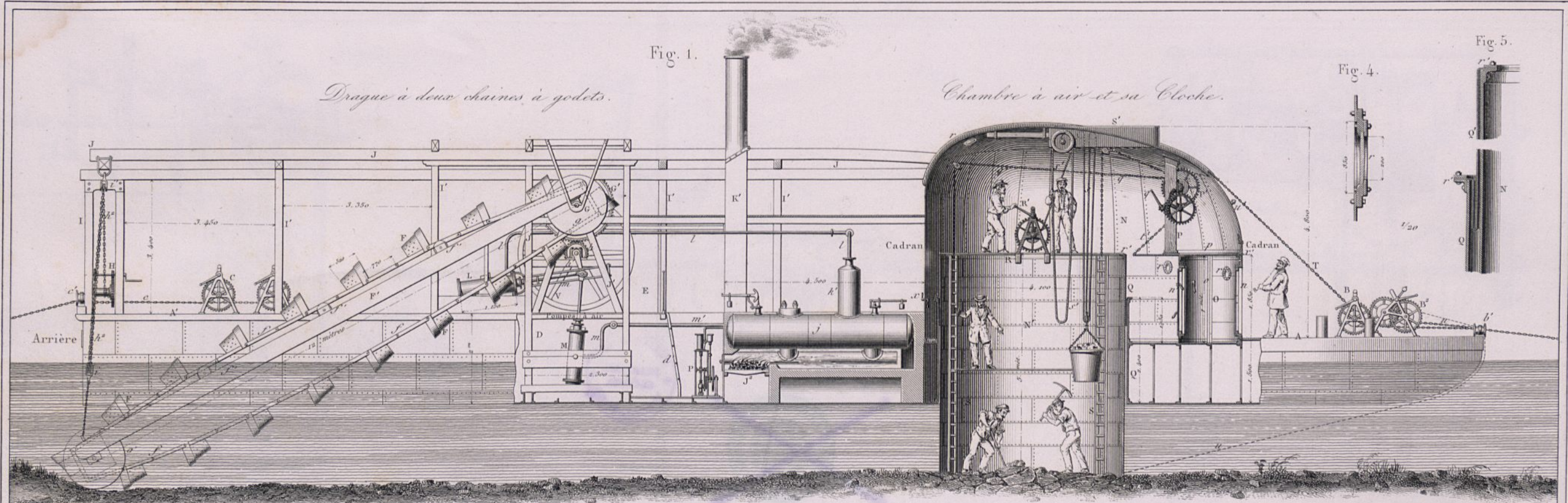


Fig. 1.

Drague à deux chaînes à godets.

Chambre à air et sa Cloche.

Longueur totale du bateau = 32 mètres.

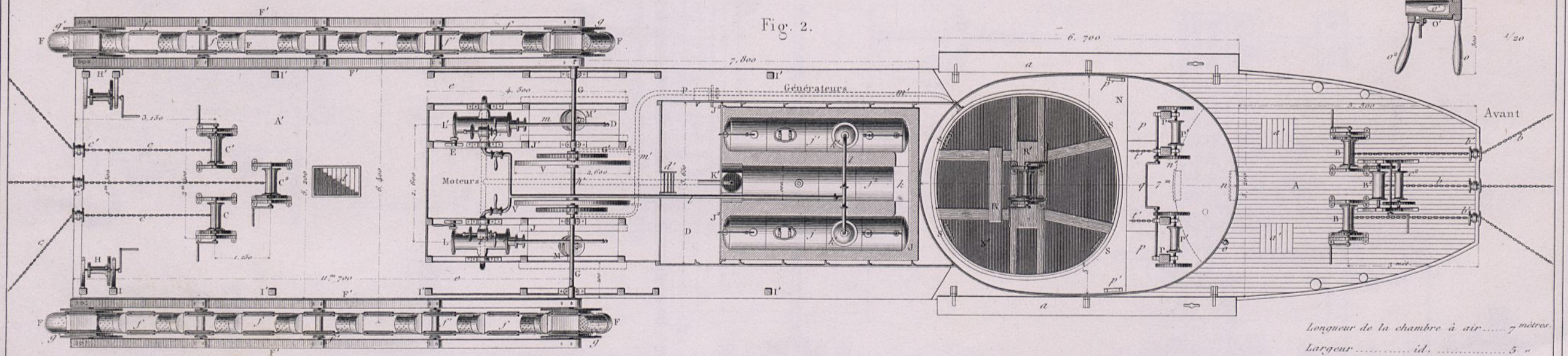
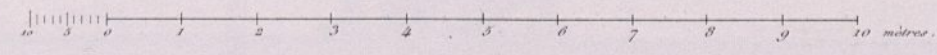


Fig. 2.

Echelle de 1/100.



Longueur de la chambre à air..... 7 mètres
 Largeur..... id..... 5 "
 Diamètre de la cloche..... 4,100
 Hauteur..... id..... 5 "

Fig. 4.

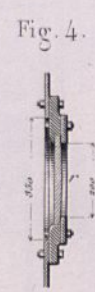


Fig. 5.

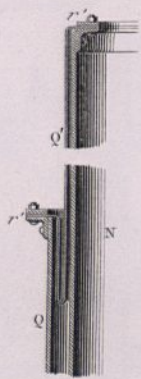
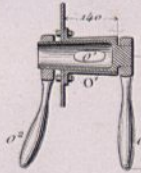


Fig. 3.





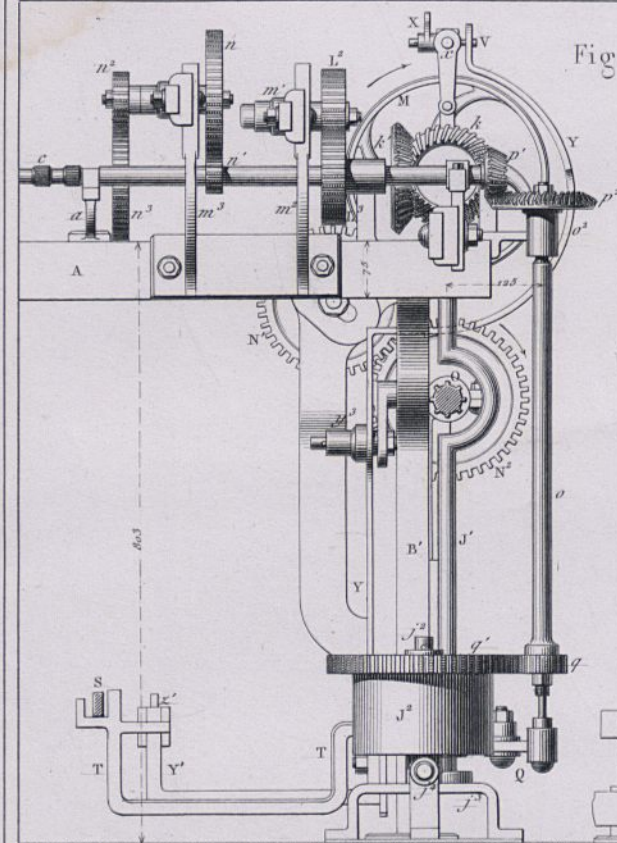


Fig. 3.

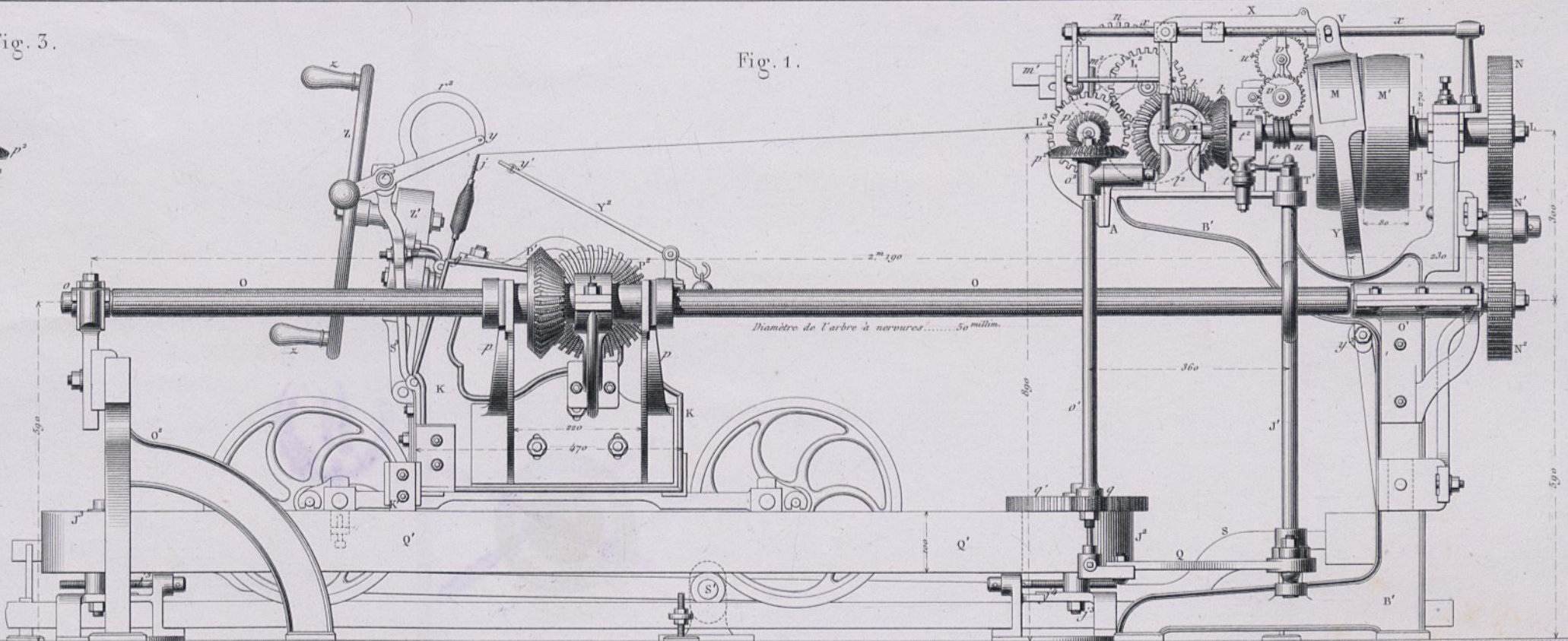


Fig. 1.

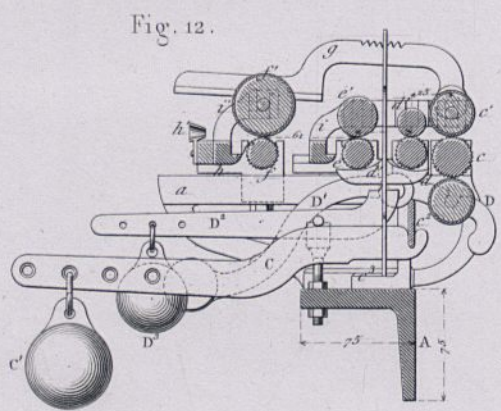


Fig. 12.

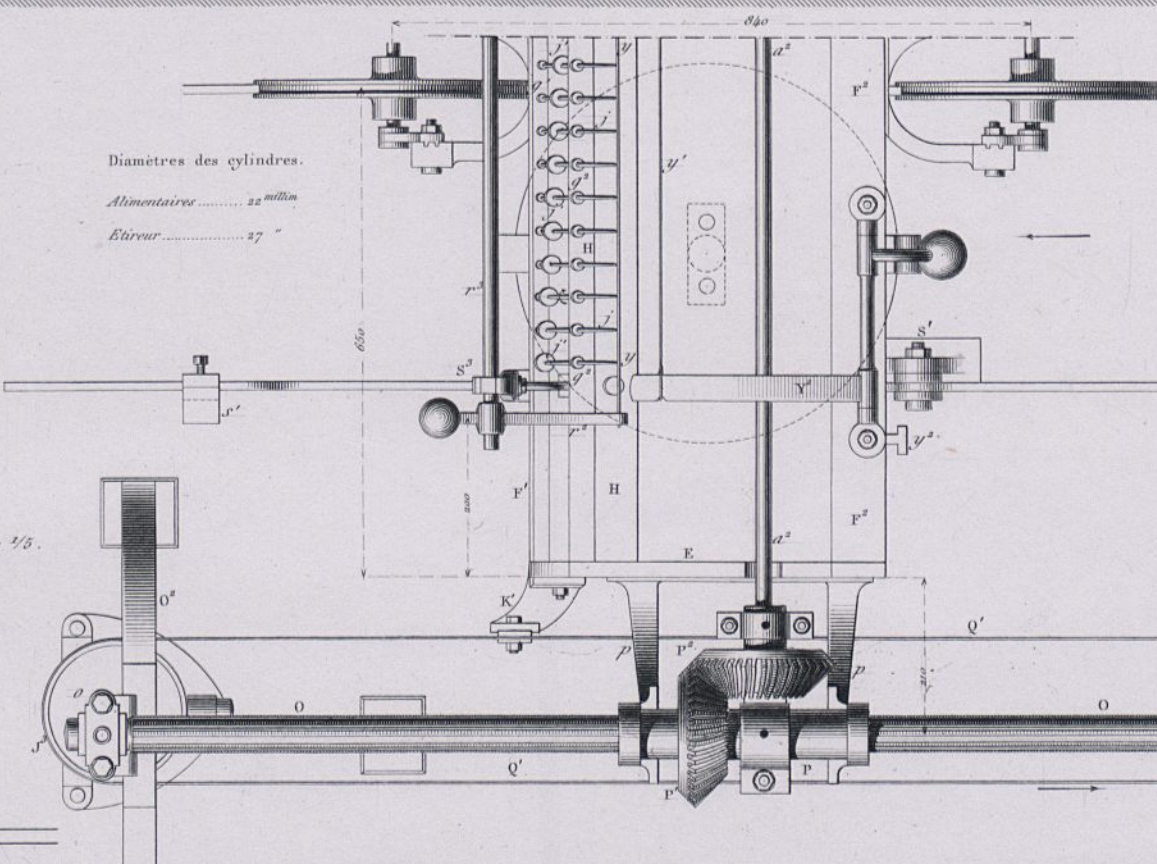


Fig. 2.

Diamètres des cylindres.
 Alimentaires..... 22 millim
 Étirer..... 27 "

Echelle de 1/10

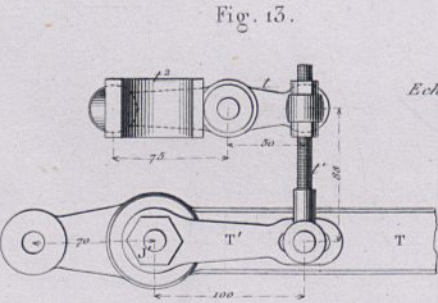
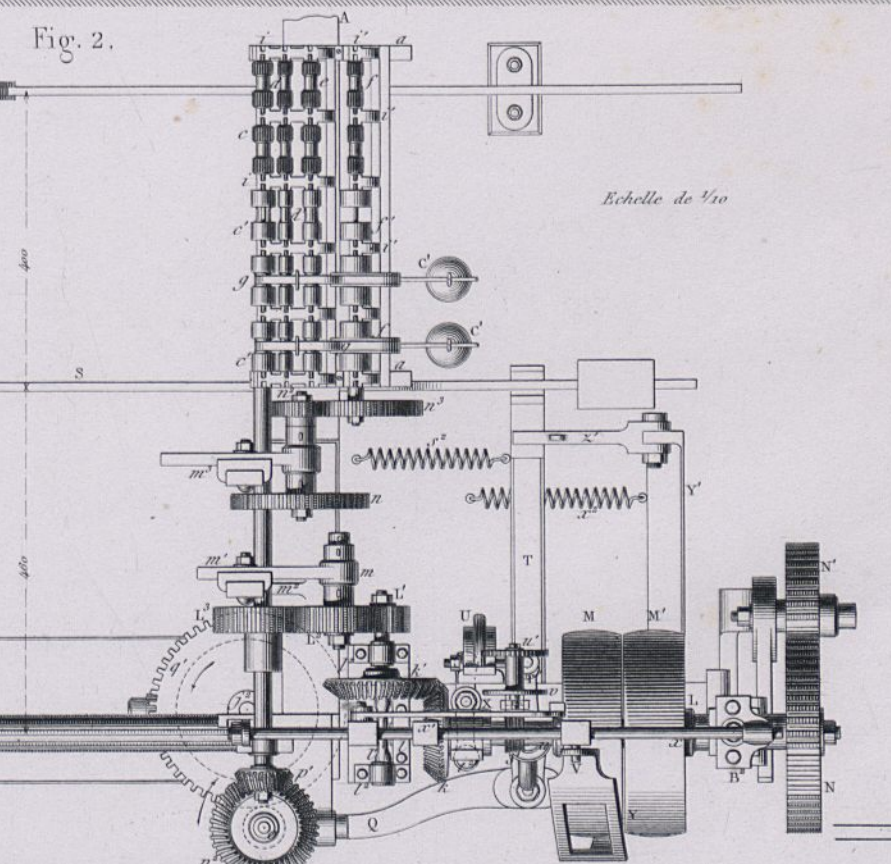
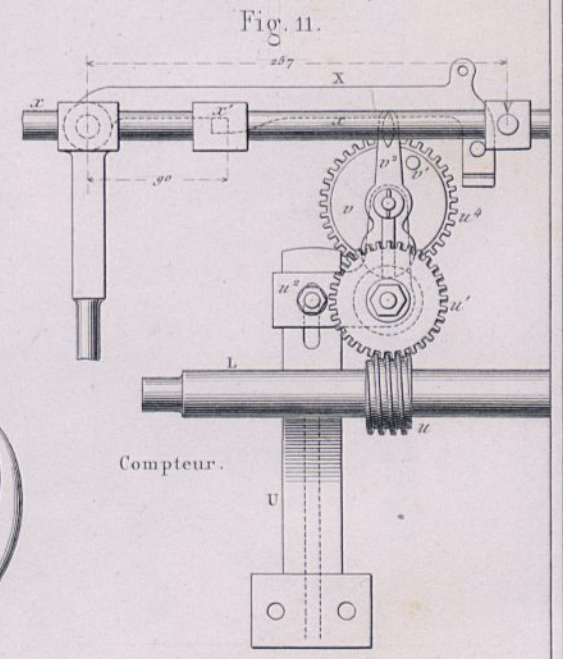
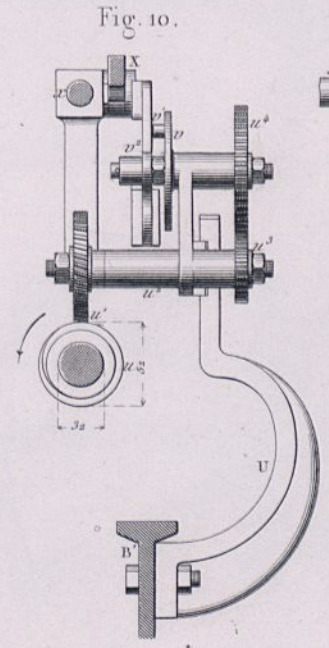
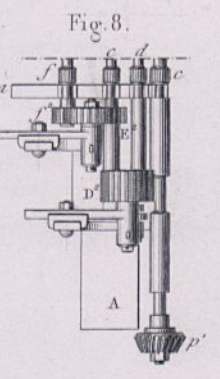
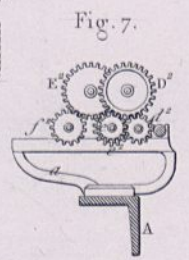
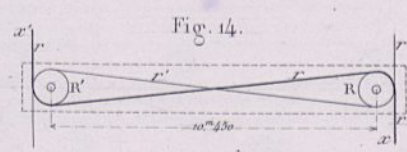
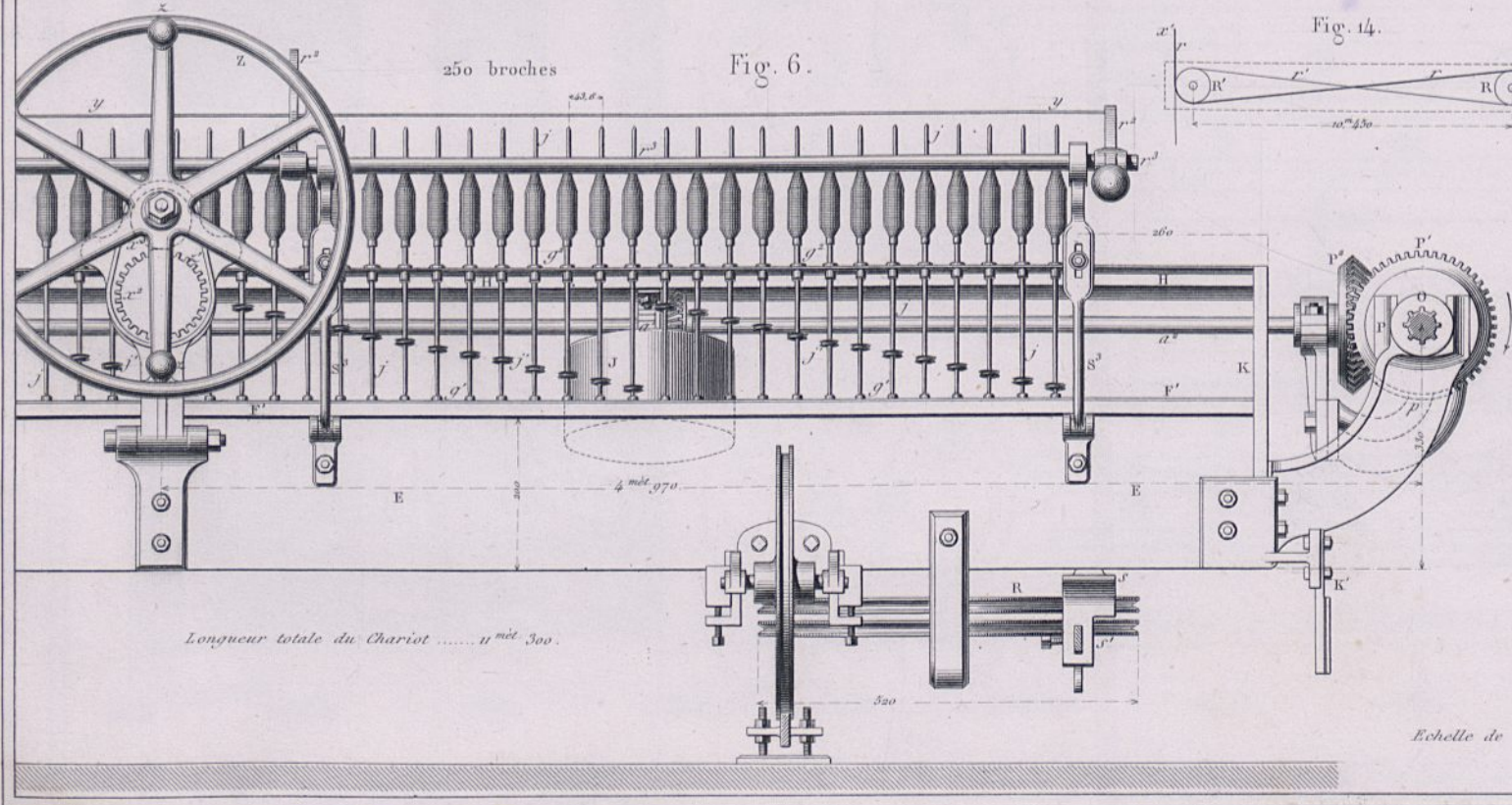
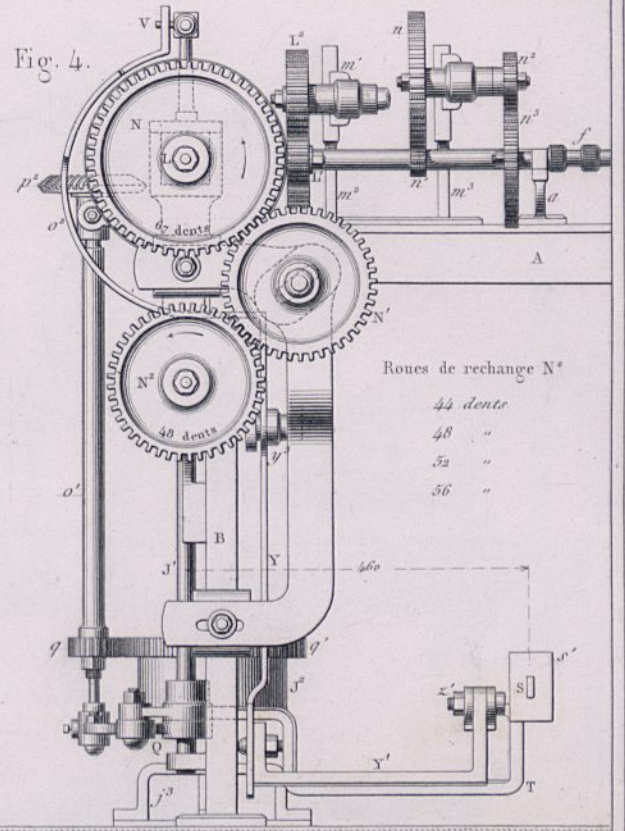
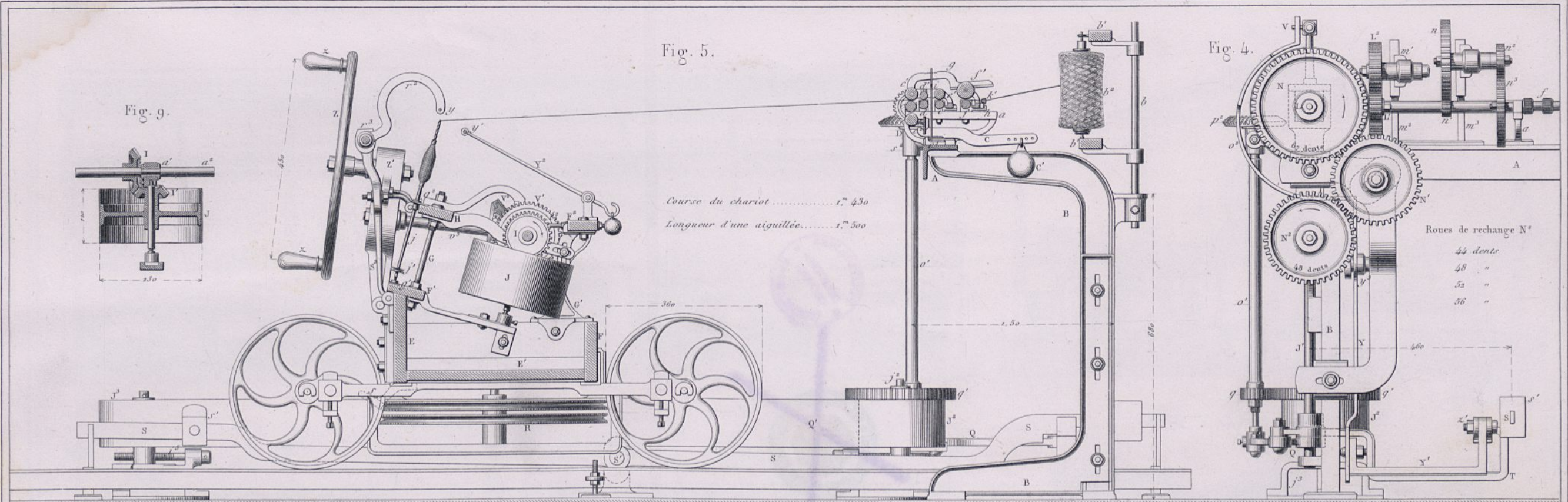


Fig. 13.

Echelle de 1/5.







Echelle de 1/50 pour les Fig. 5 à 8.

Echelle de 1/5.



Fig. 1.

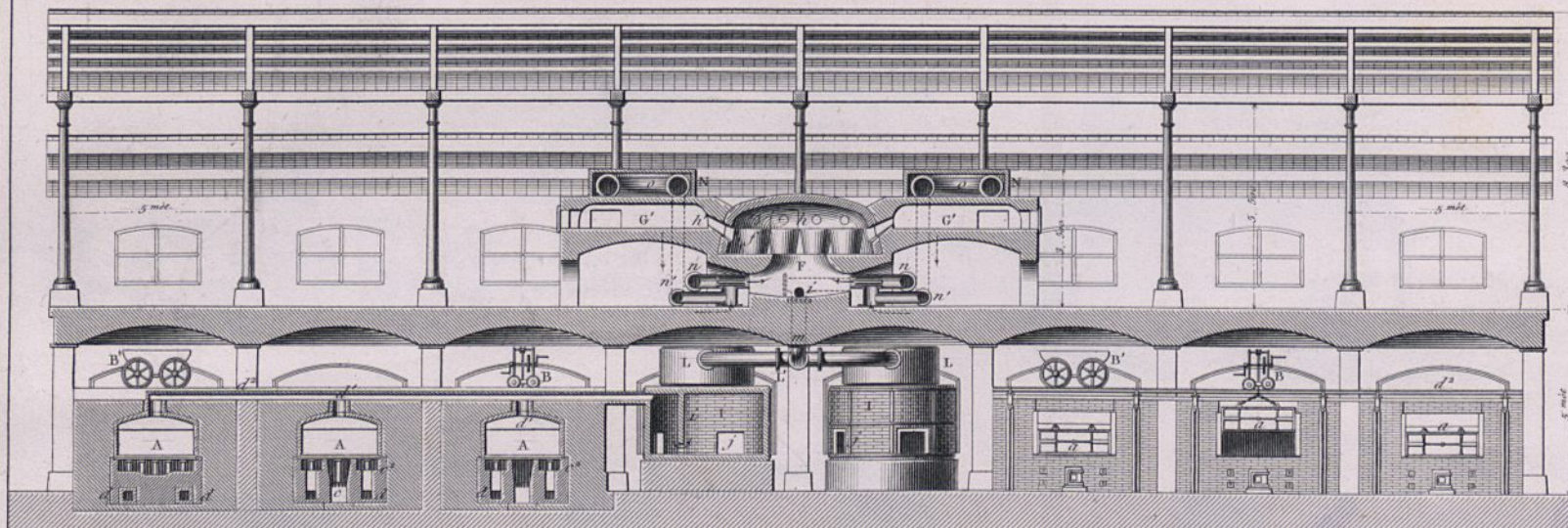


Fig. 2.

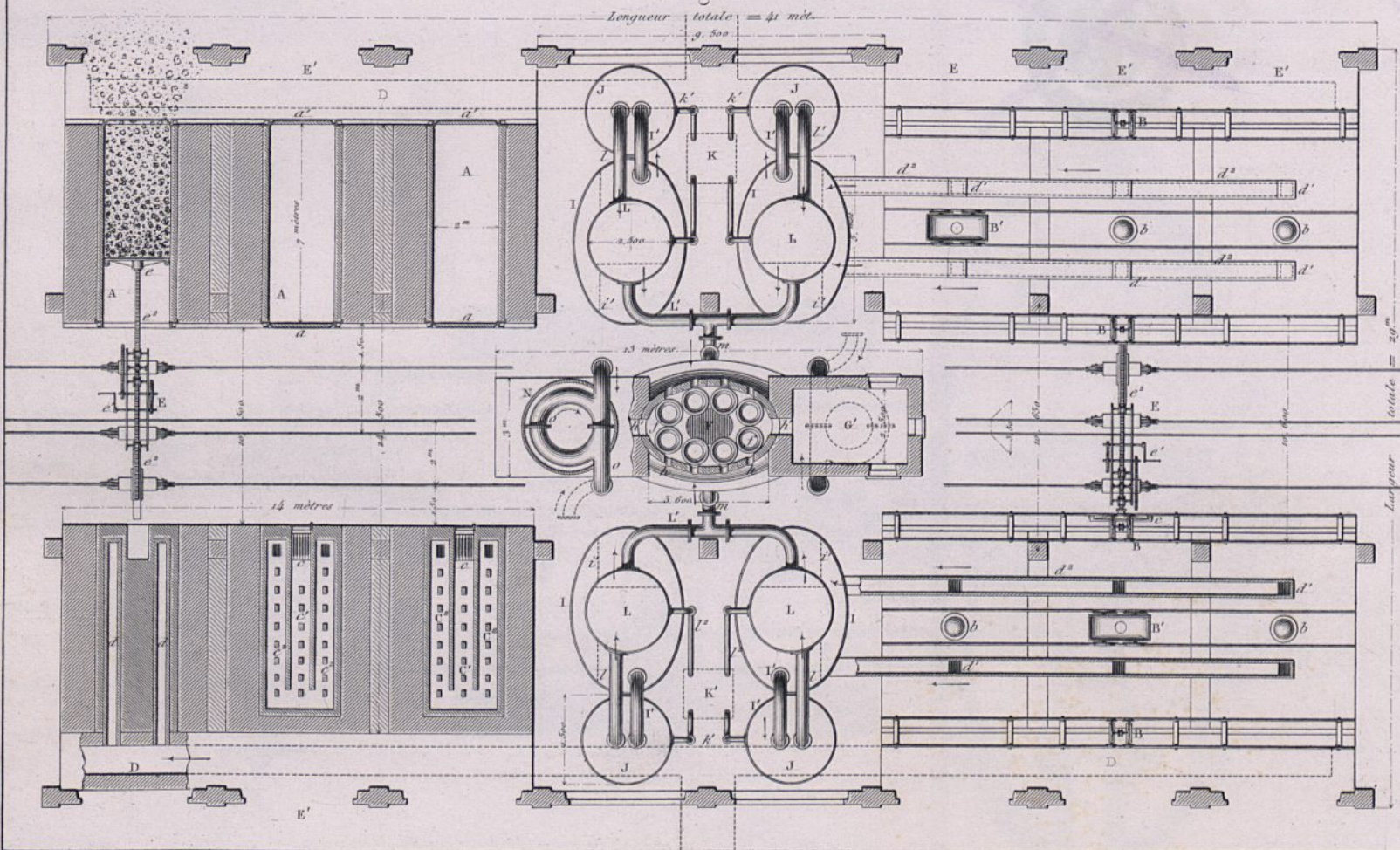
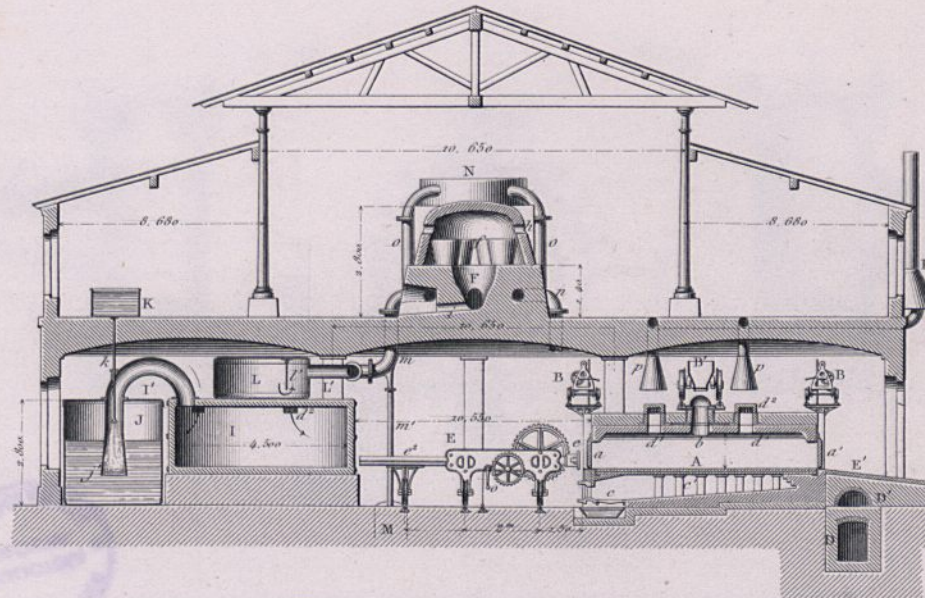


Fig. 3.



Four à vitre à la houille.

Fig. 4.

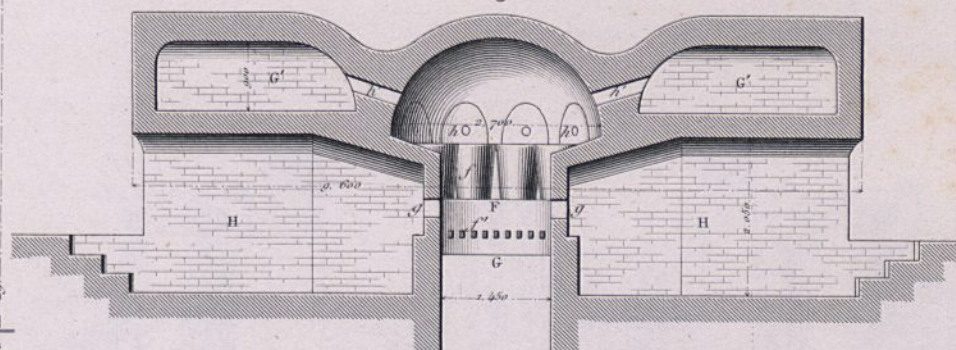
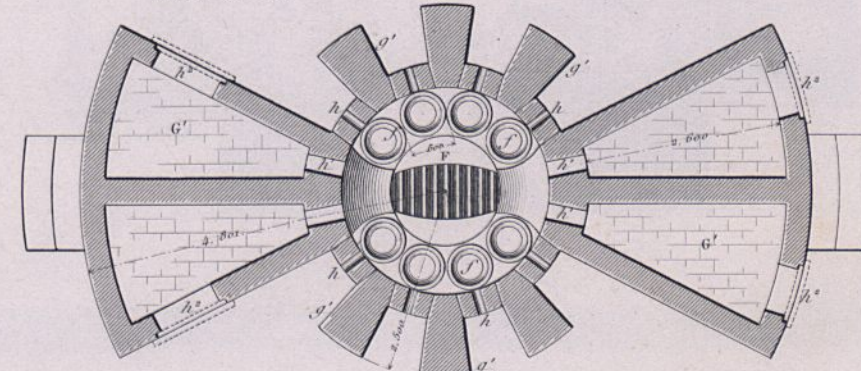


Fig. 5.



Echelle de 1/100. Echelle de 1/500 pour les Fig. 1 à 3.



Fig. 2.

Pompe à double effet.

Cylindre à vapeur.

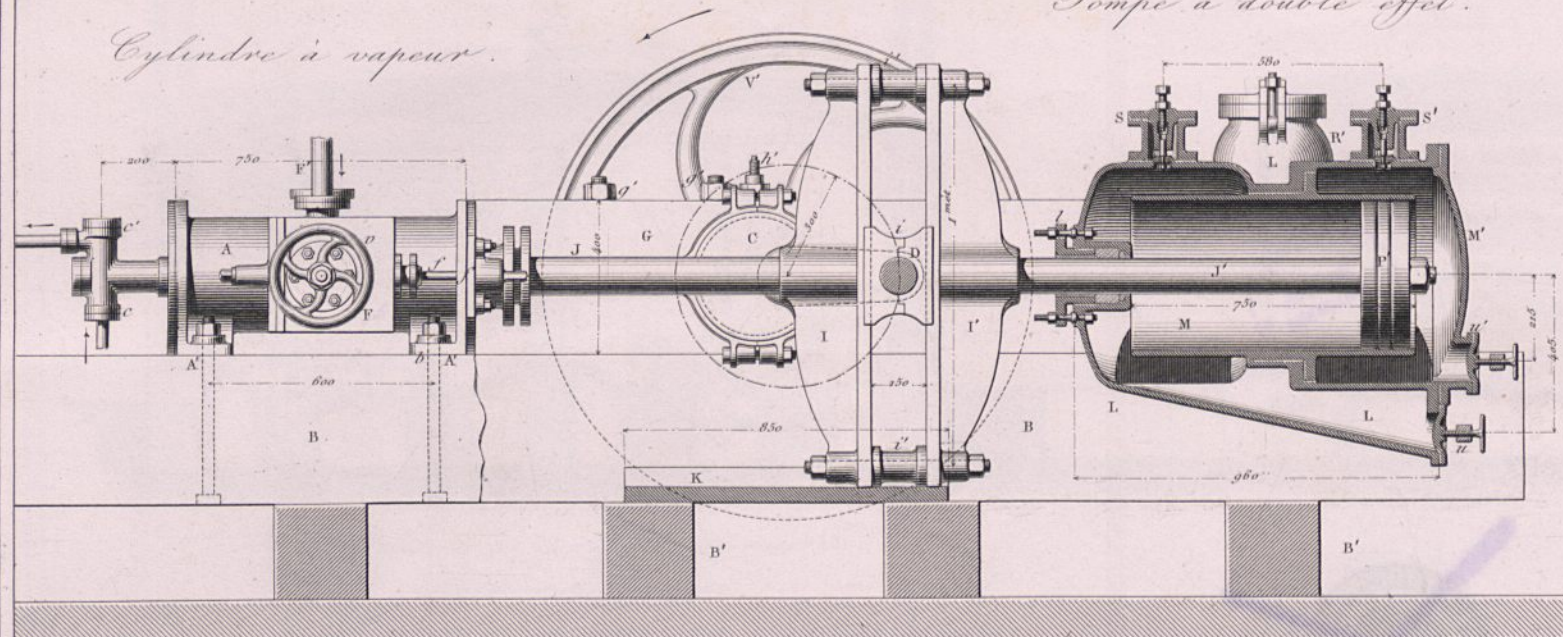


Fig. 3.

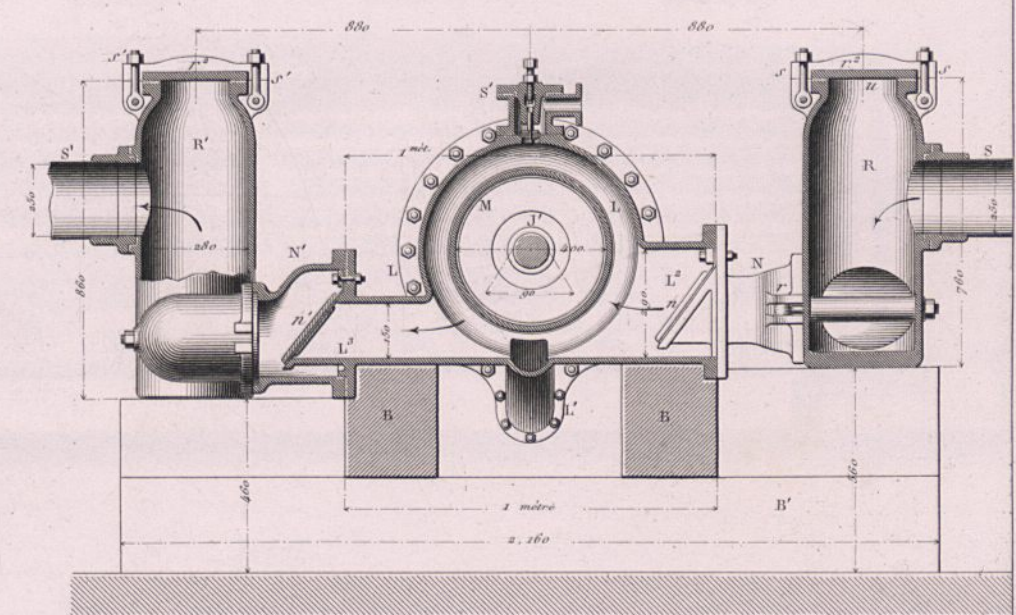


Fig. 5.

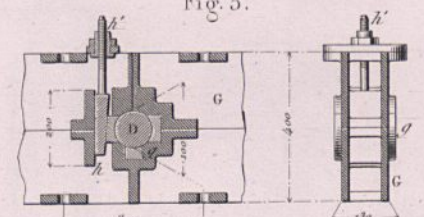


Fig. 1.

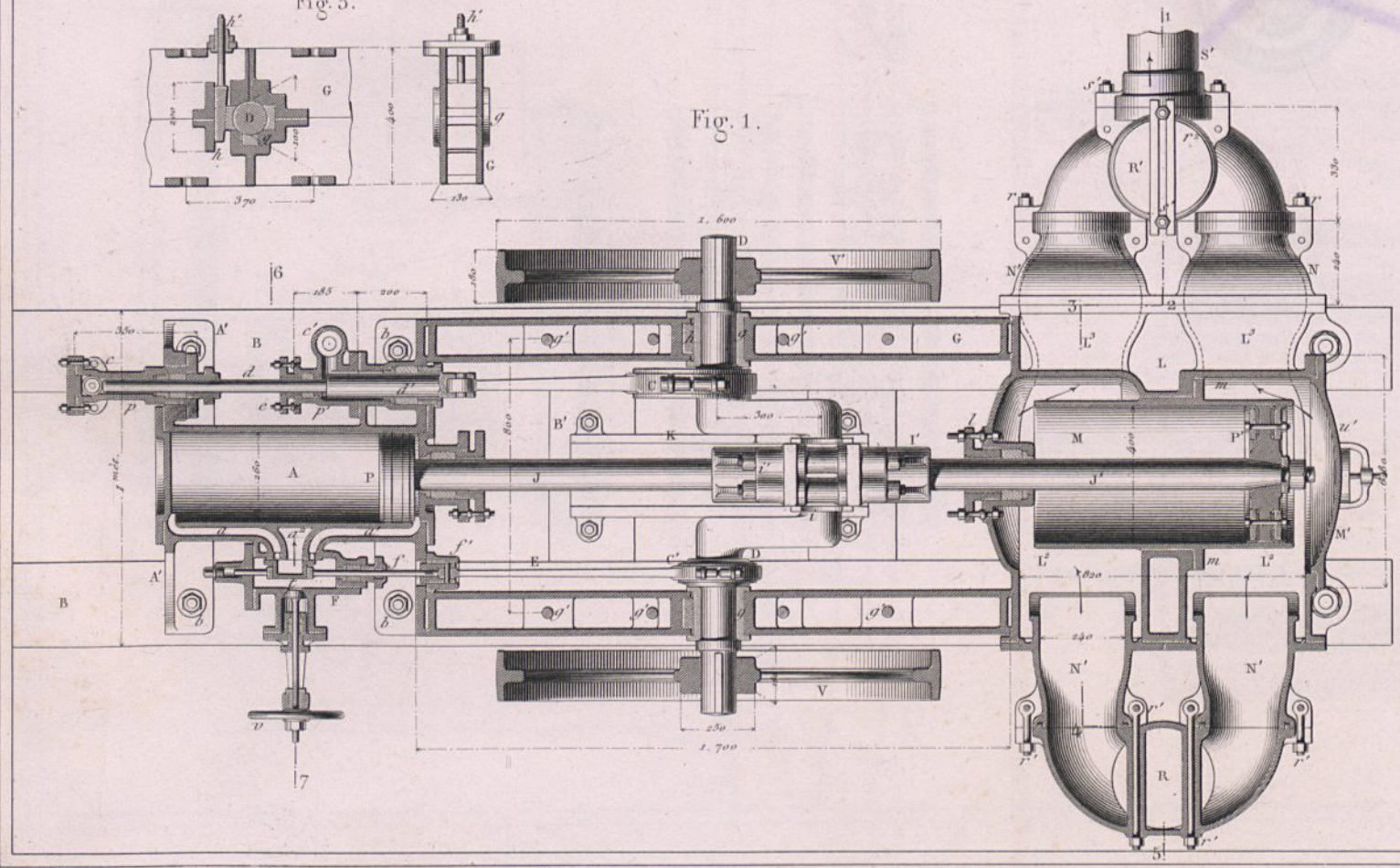
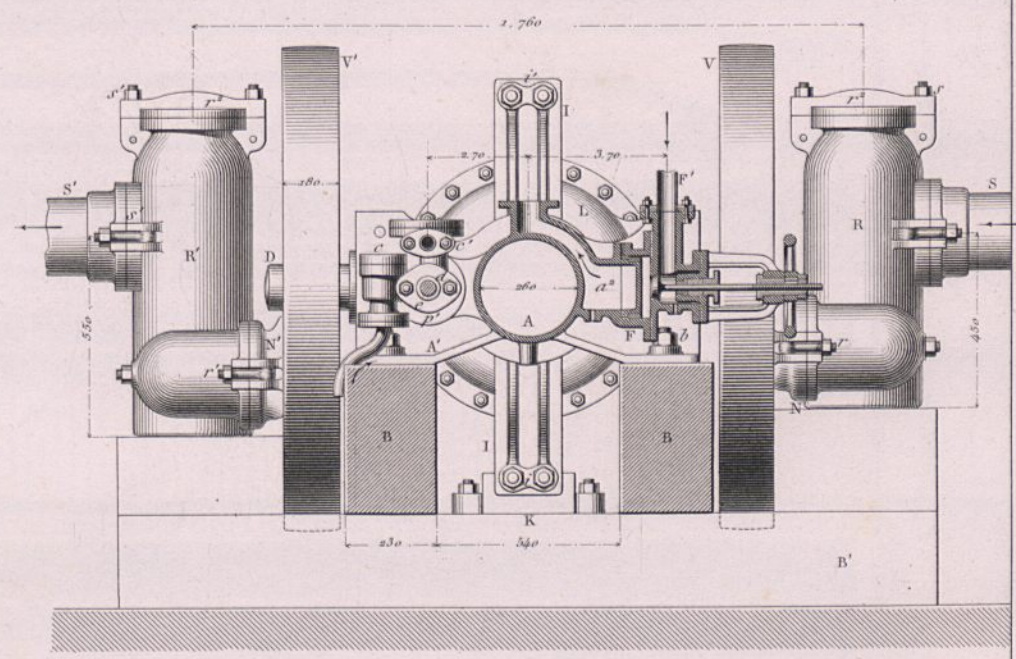


Fig. 4.



Echelle de 1/20.

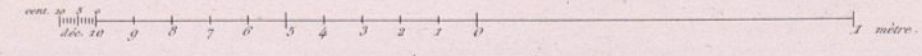




Fig. 4.

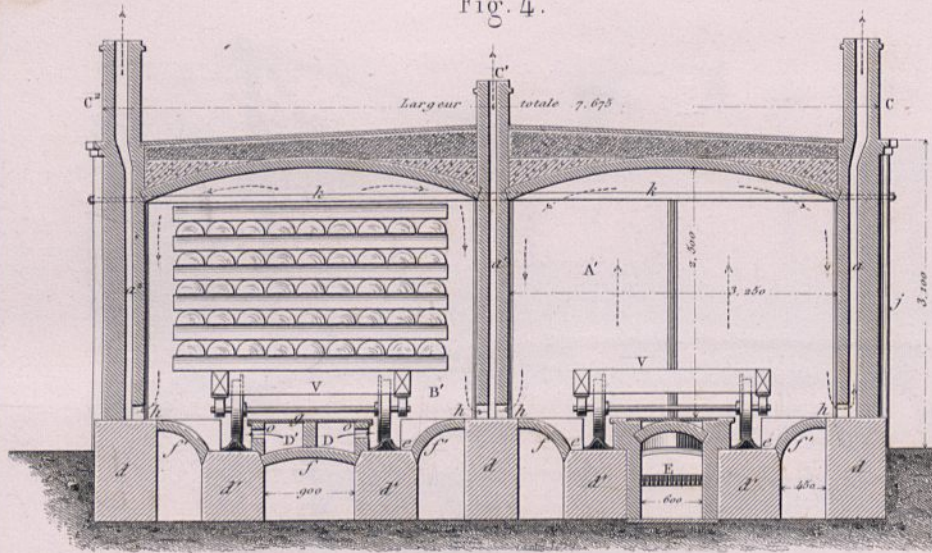
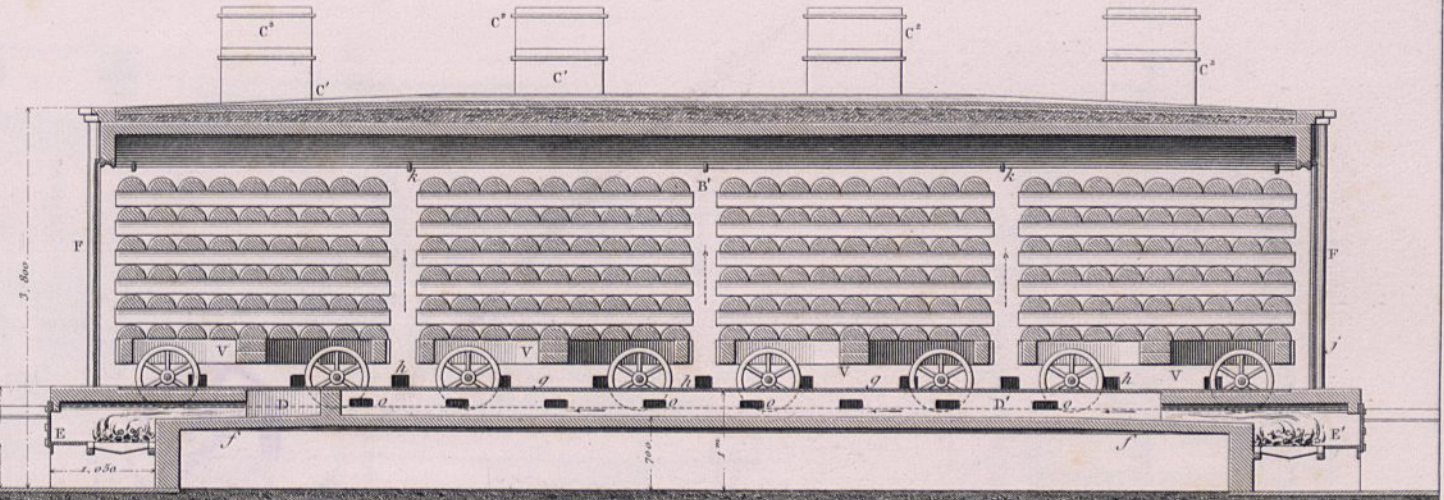


Fig. 3.



*Injection au sulfate de cuivre.
Chantier de Bordeaux*

Fig. 1.

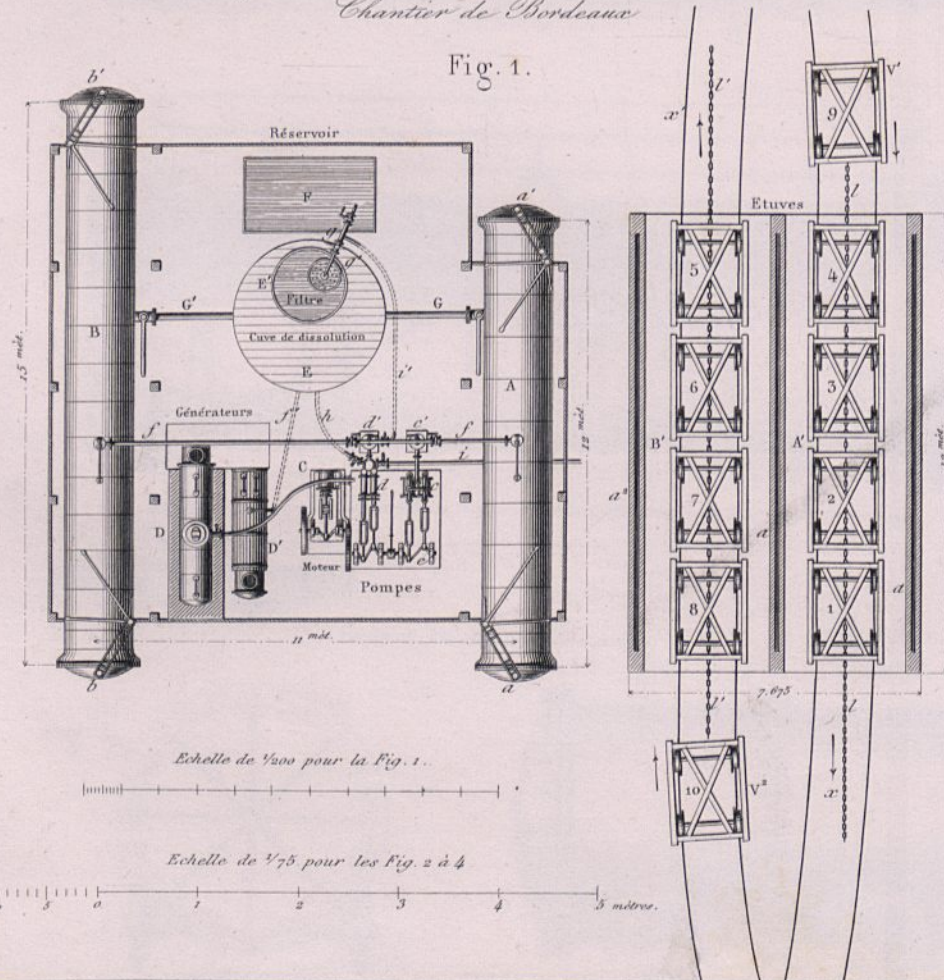
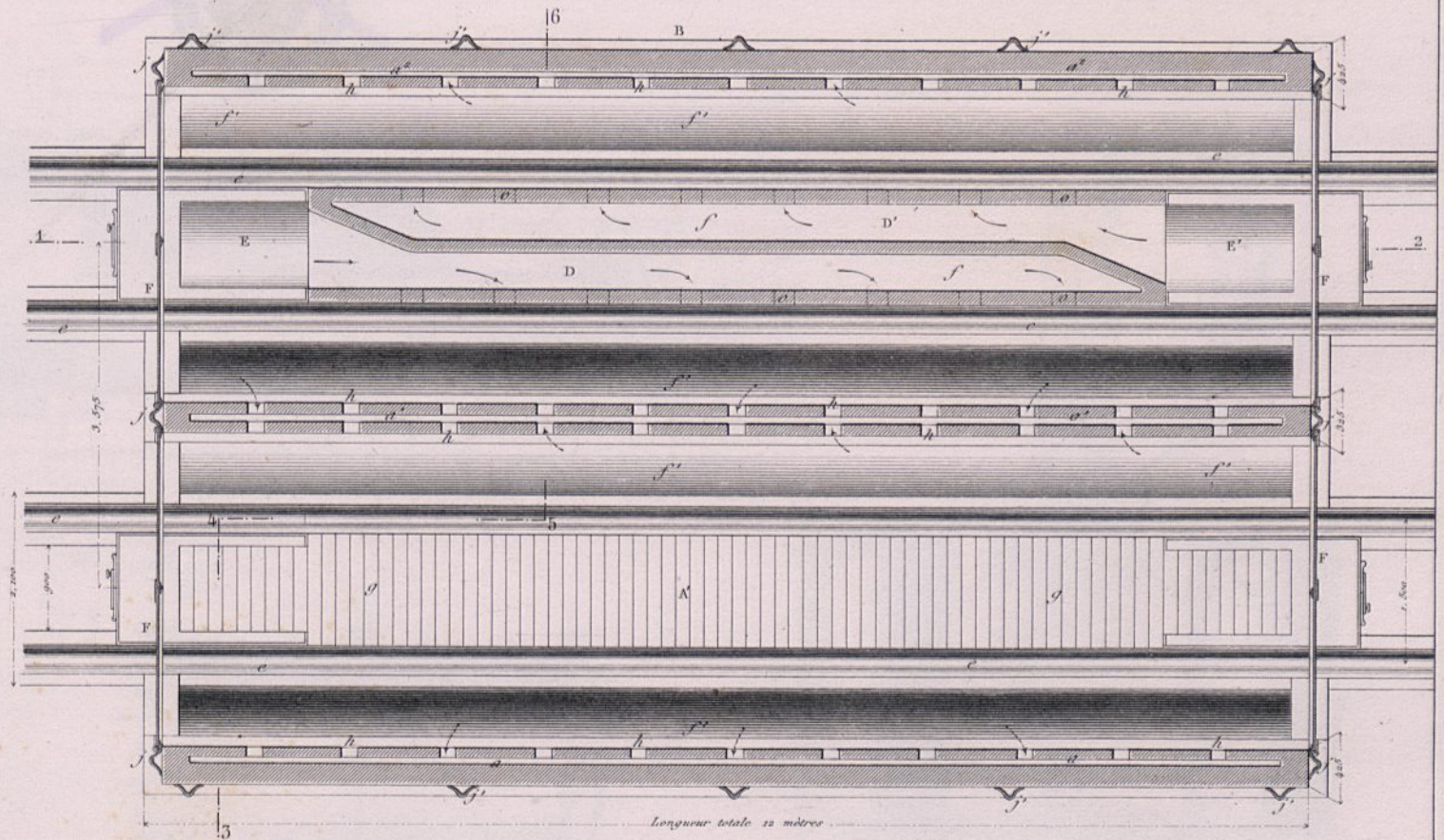
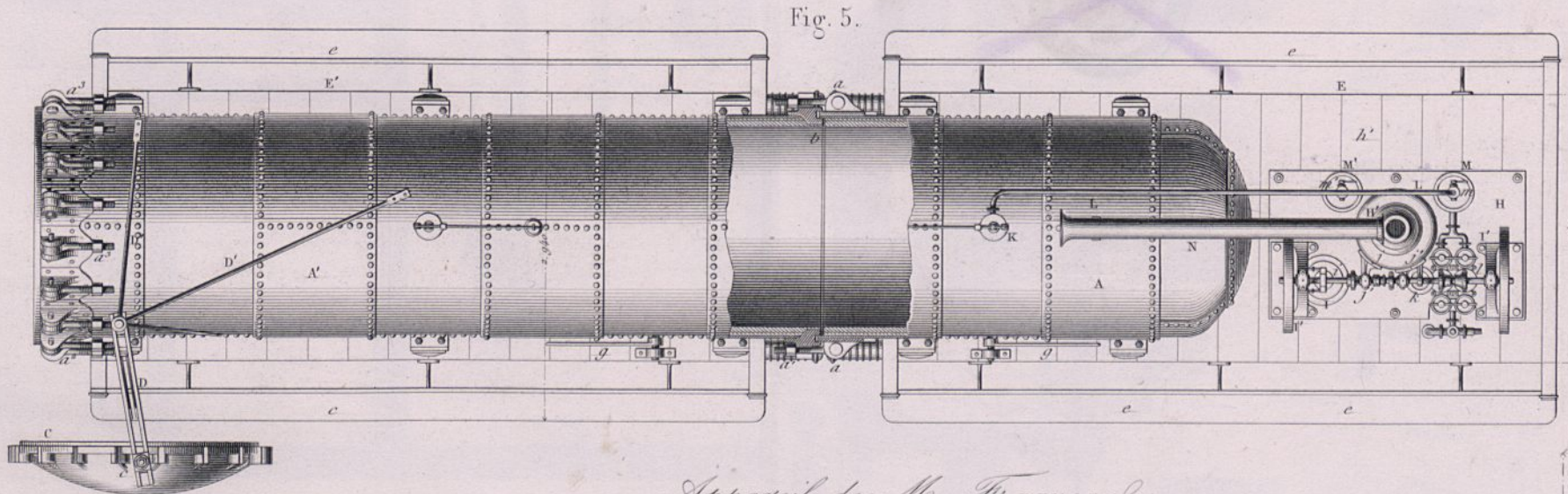
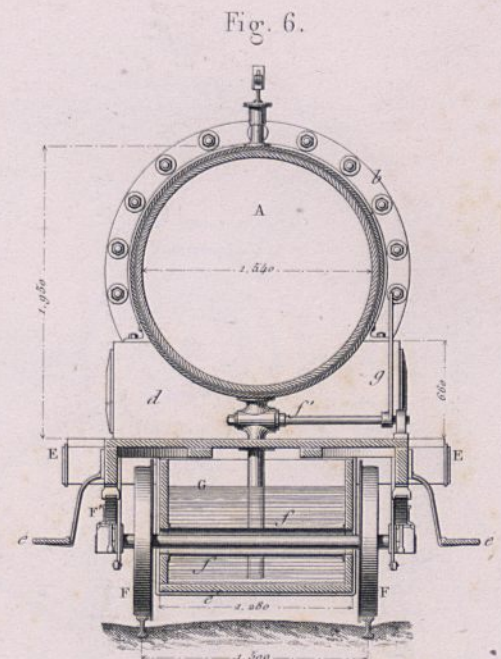
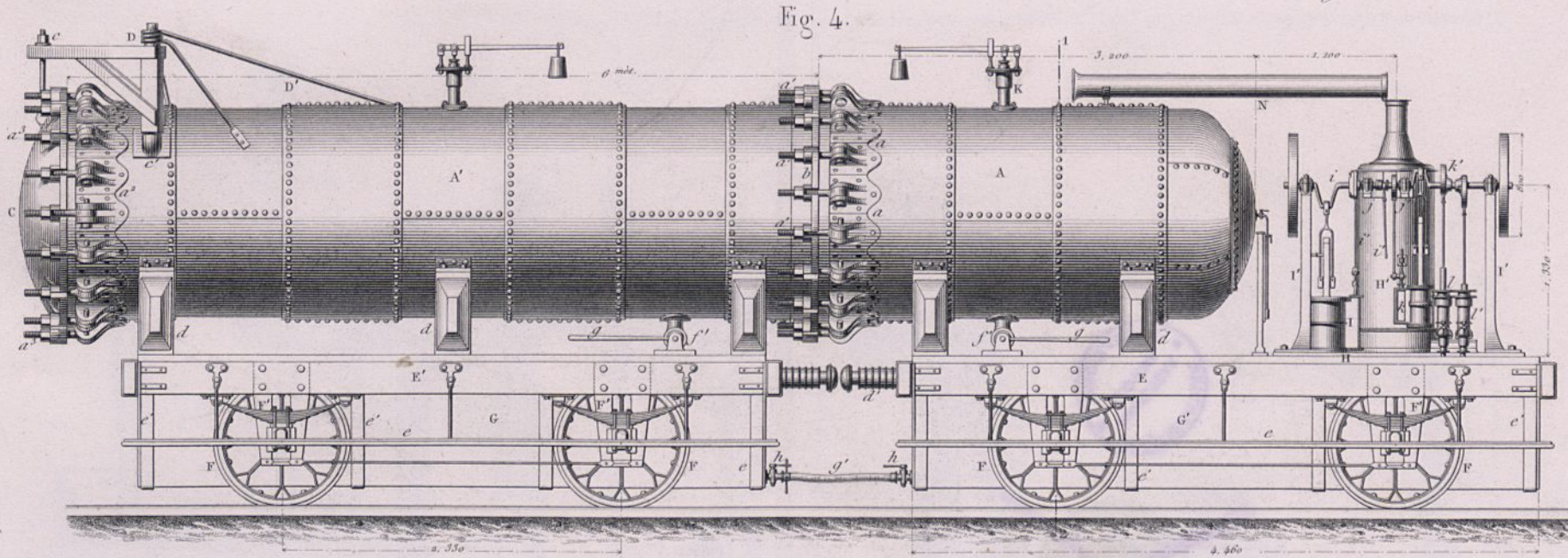


Fig. 2.

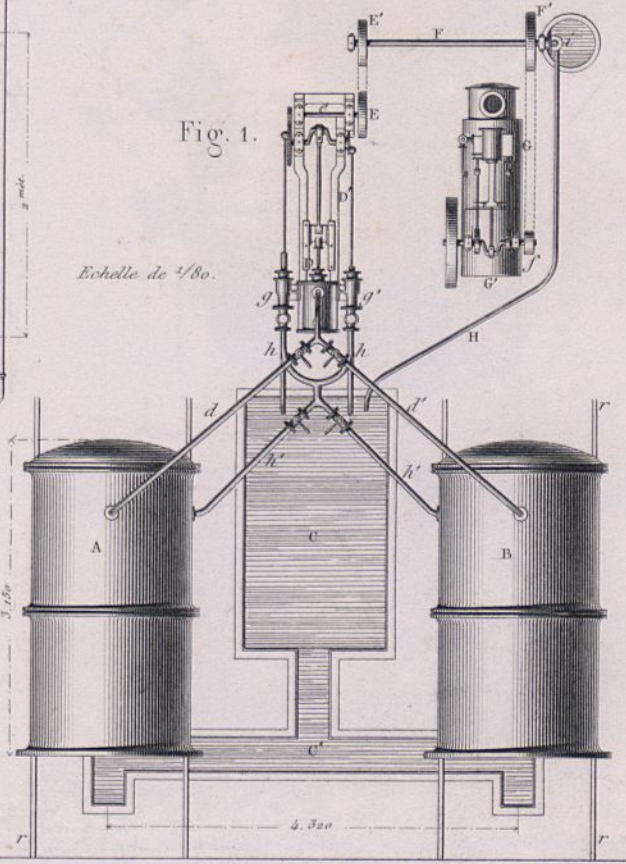




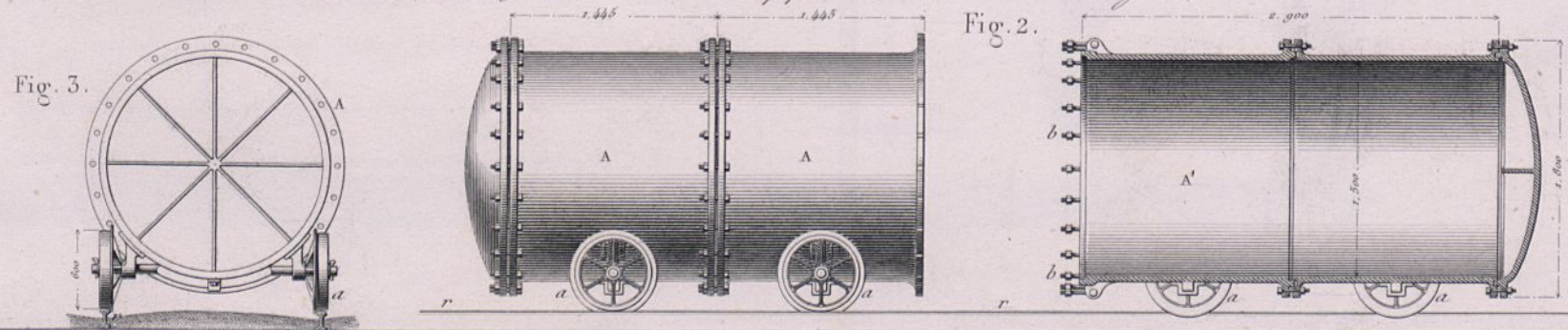
Appareil de M. M. Dorsett et Blythe.



Installation du Chantier de Barsac.



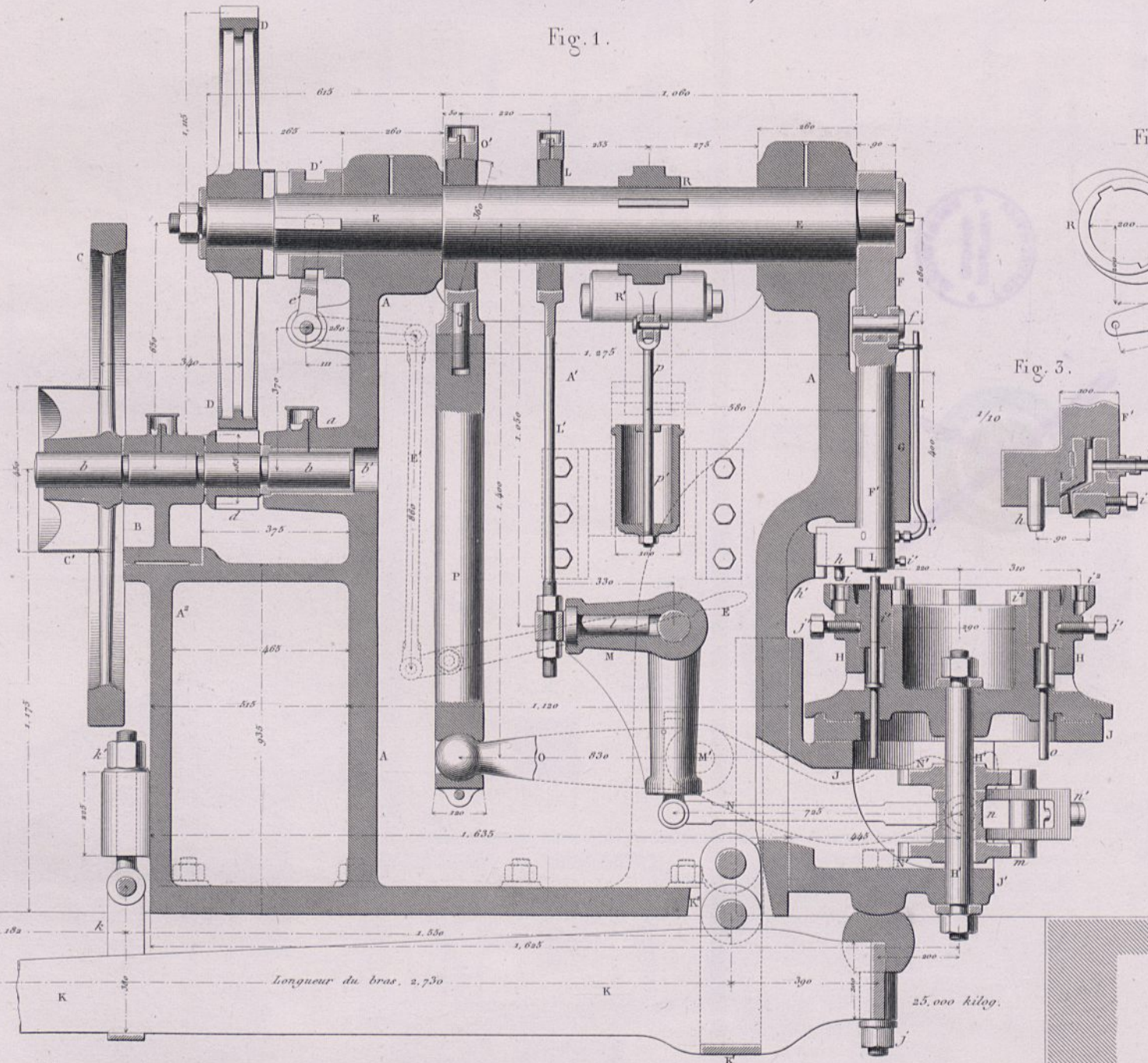
Appareil de M. Fragneau





Système à poinçon vertical et à porte-matrices tournant.

Fig. 1.



Poids suspendu à l'extrémité du levier = 400 kilogrammes.

Echelle de $\frac{1}{15}$.

Déc. 10 9 8 7 6 5 4 3 2 1 0

Fig. 2.

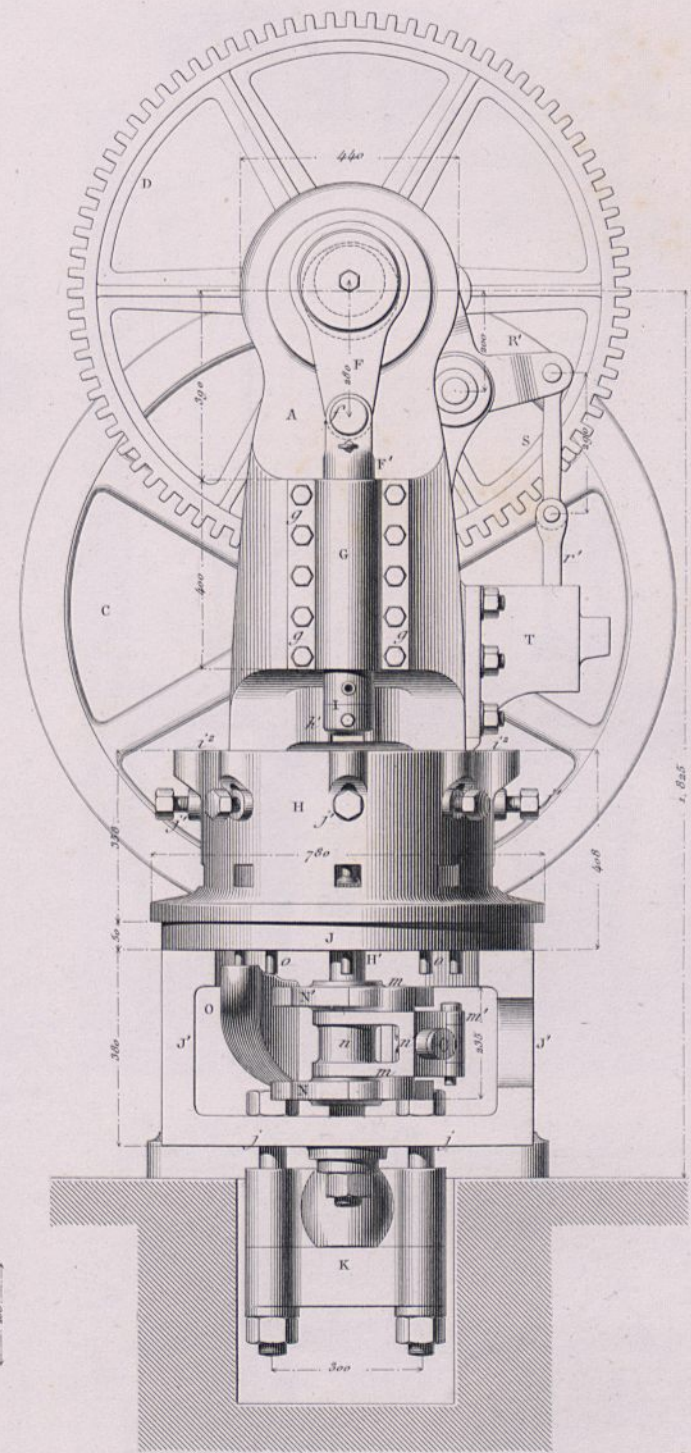


Fig. 5. Cisaille.

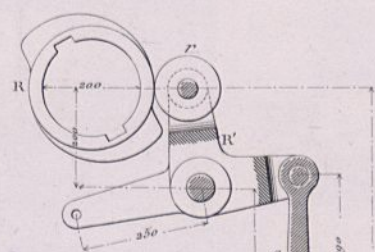


Fig. 3.

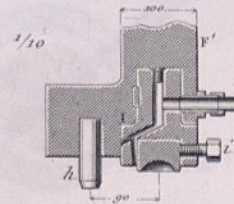


Fig. 6.

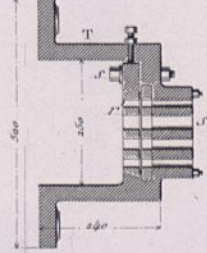
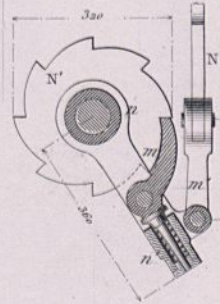


Fig. 4.



2 Mètres.



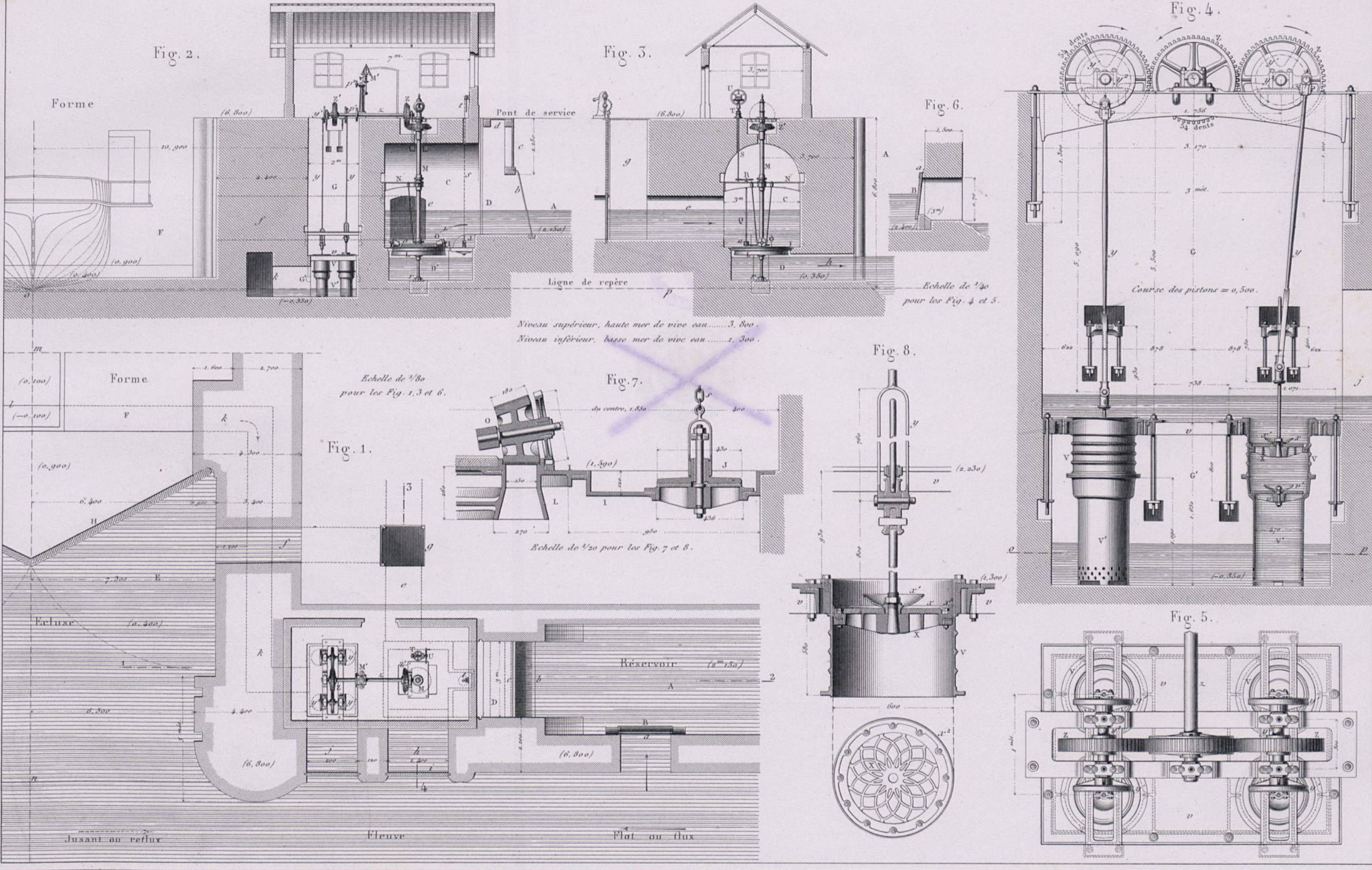




Fig. 2.

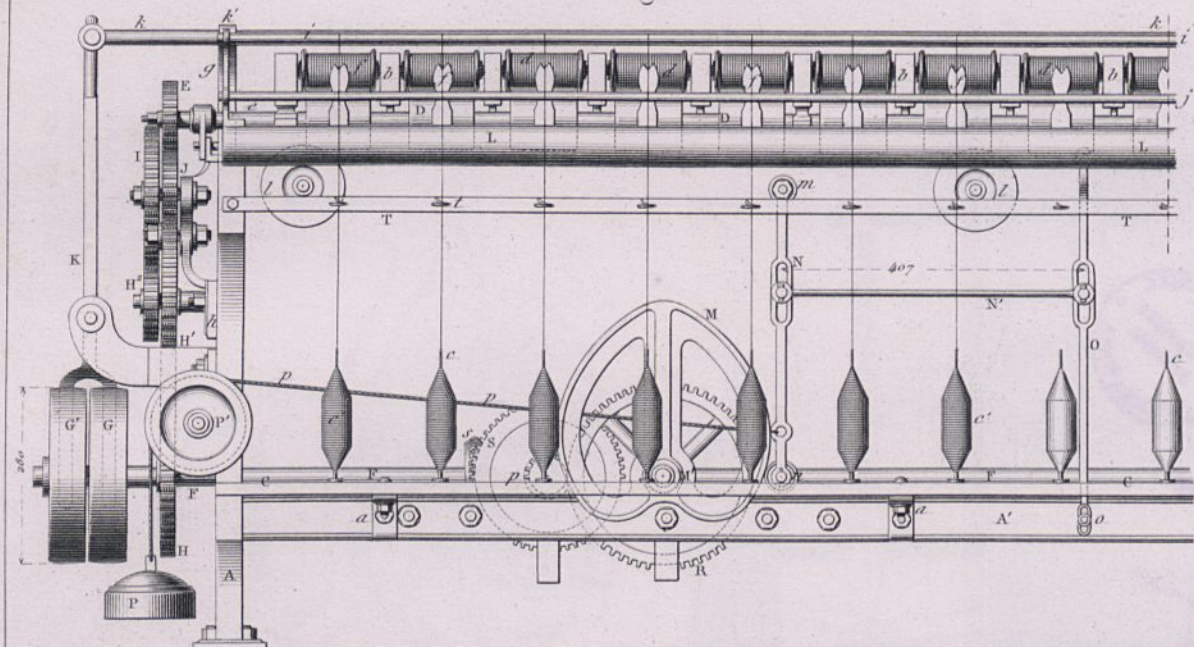


Fig. 3.

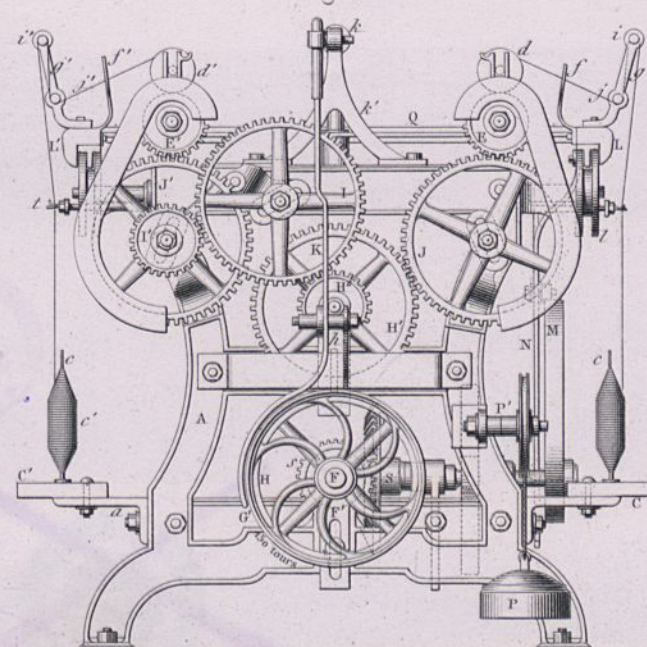


Fig. 4.

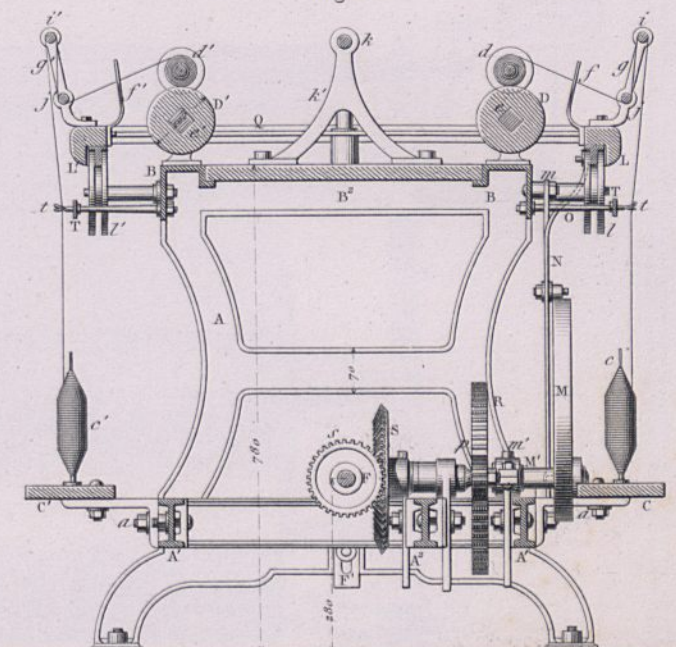
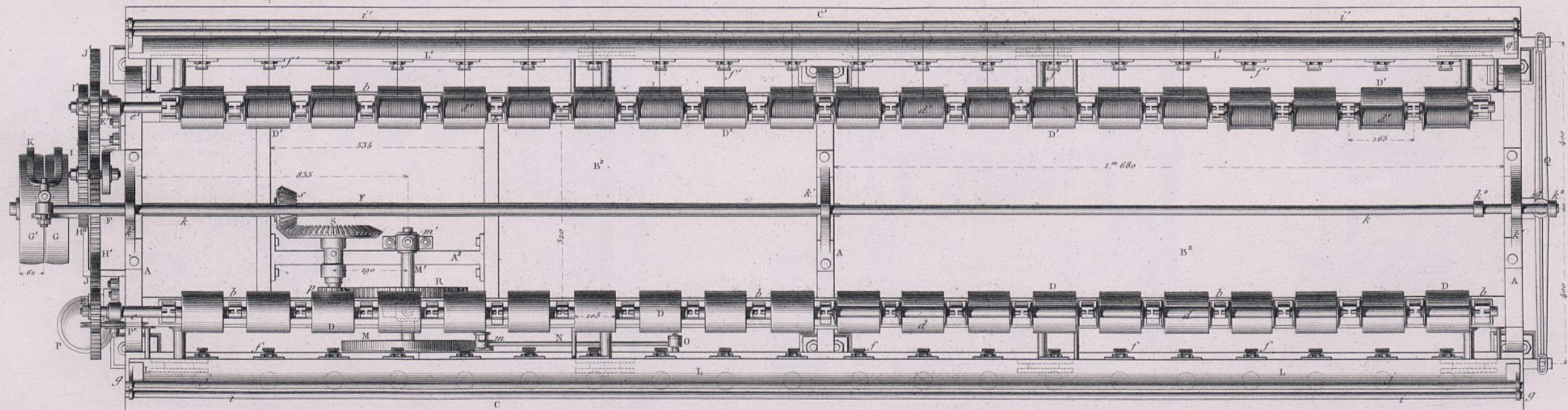


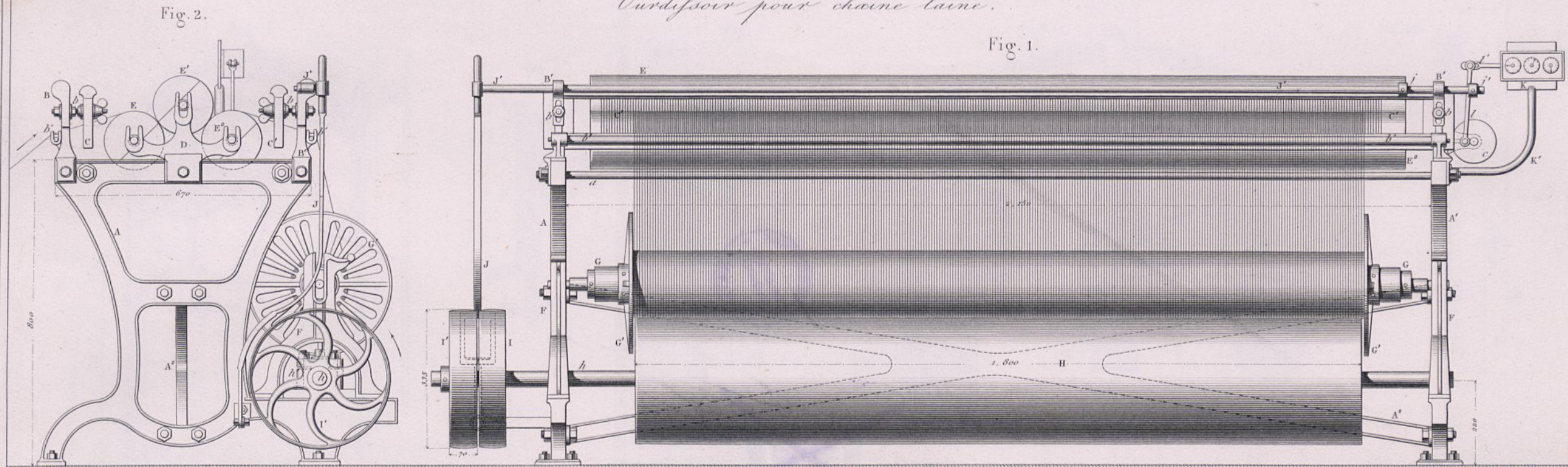
Fig. 1.



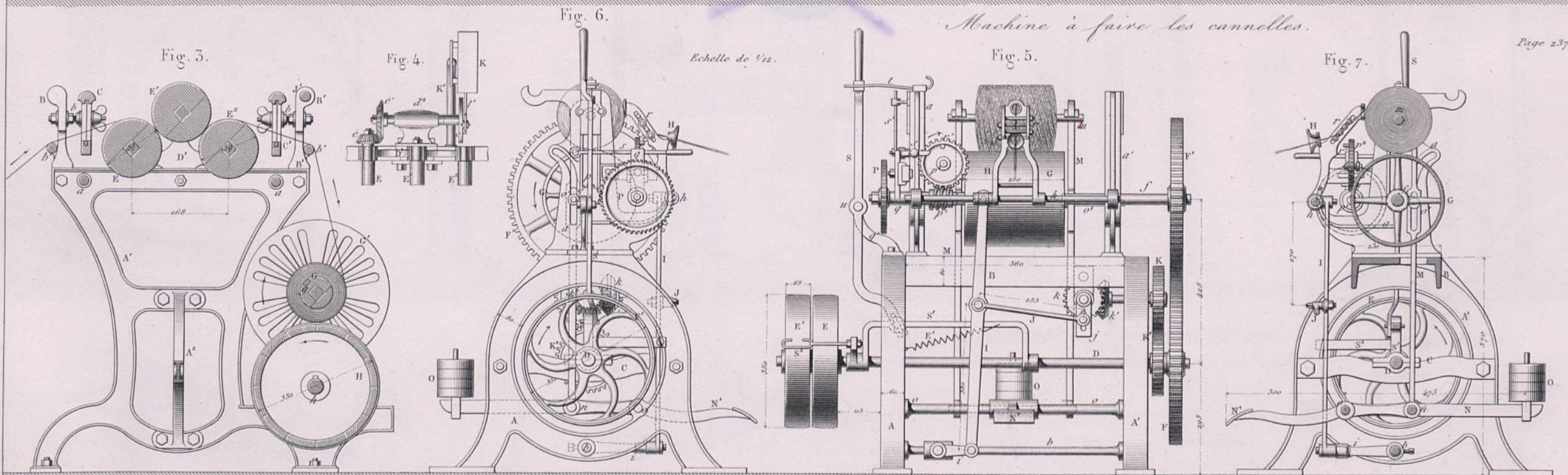
Echelle de 1/12.
 Cent. 10 5 Div. 20 9 8 7 6 5 4 3 2 1 0 2 Mètres



Ourdissoir pour chaîne laine.



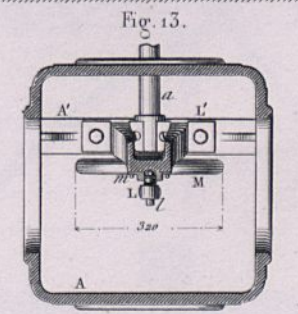
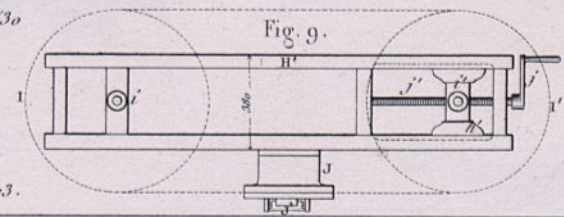
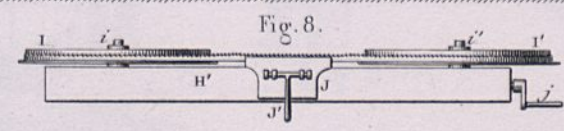
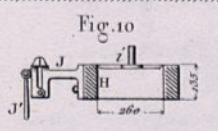
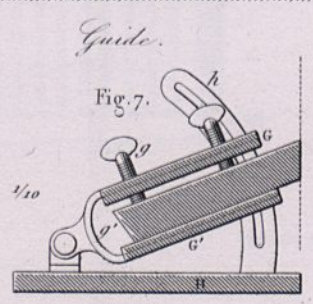
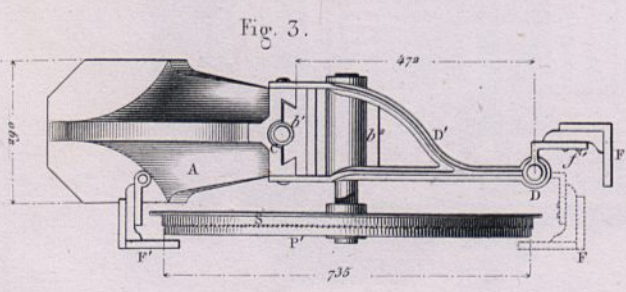
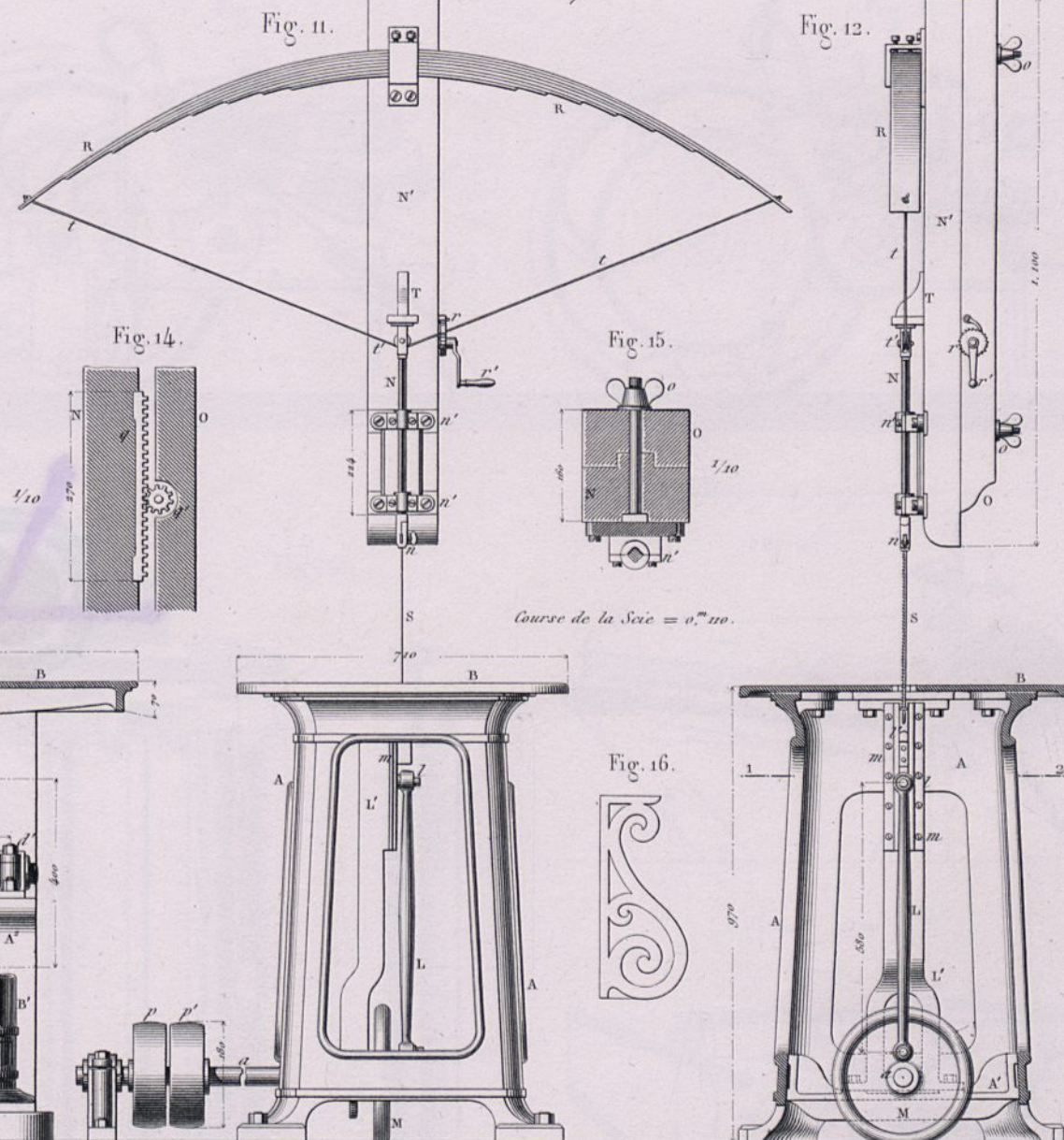
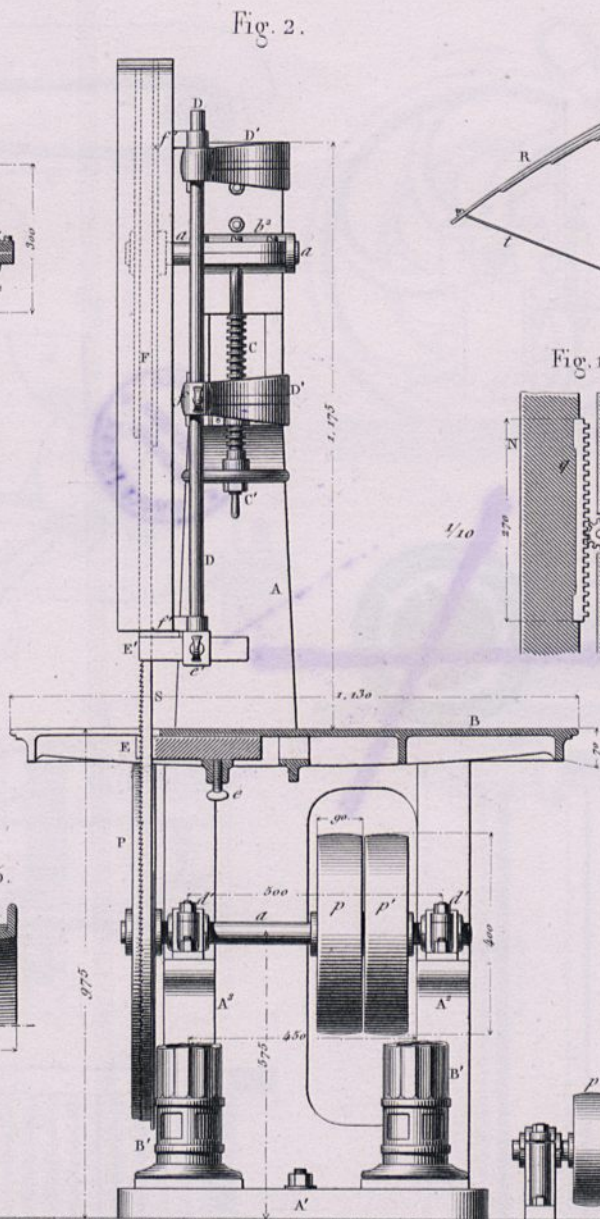
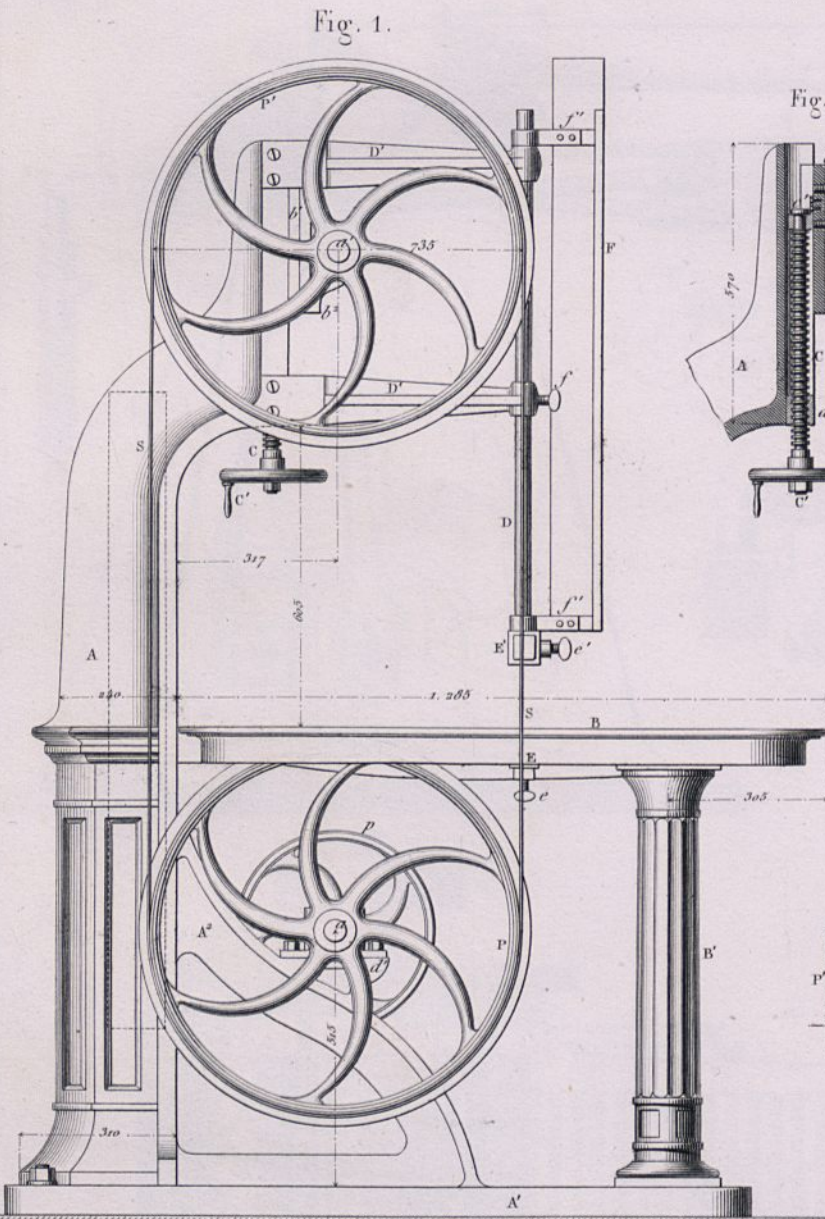
Machine à faire les cannelles.





Sciurie à lame sans fin.

Sciurie alternative à découper.



Echelle de 1/15 pour les Fig. 1 à 4, 11 à 13.

Course de la Scie = 0.110.



Mac Carthy-gin perfectionné par M. Platt.

Fig. 8.

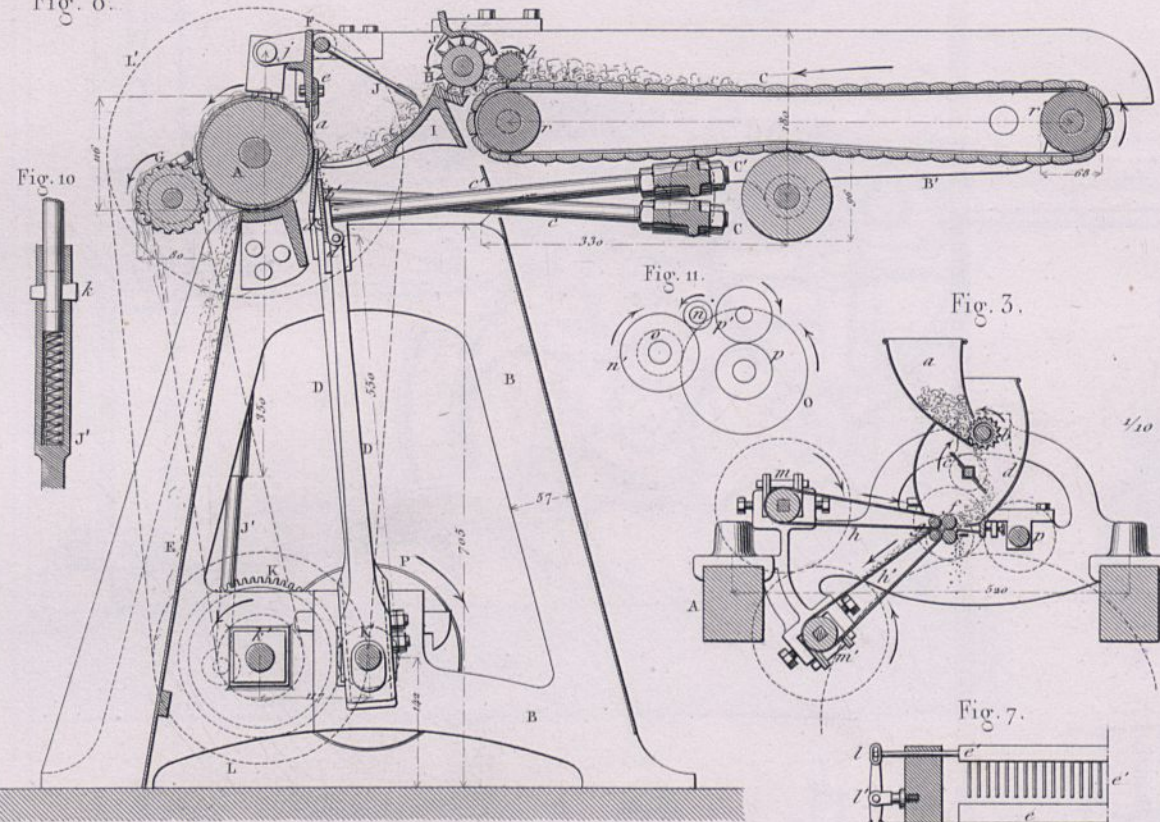


Fig. 9.

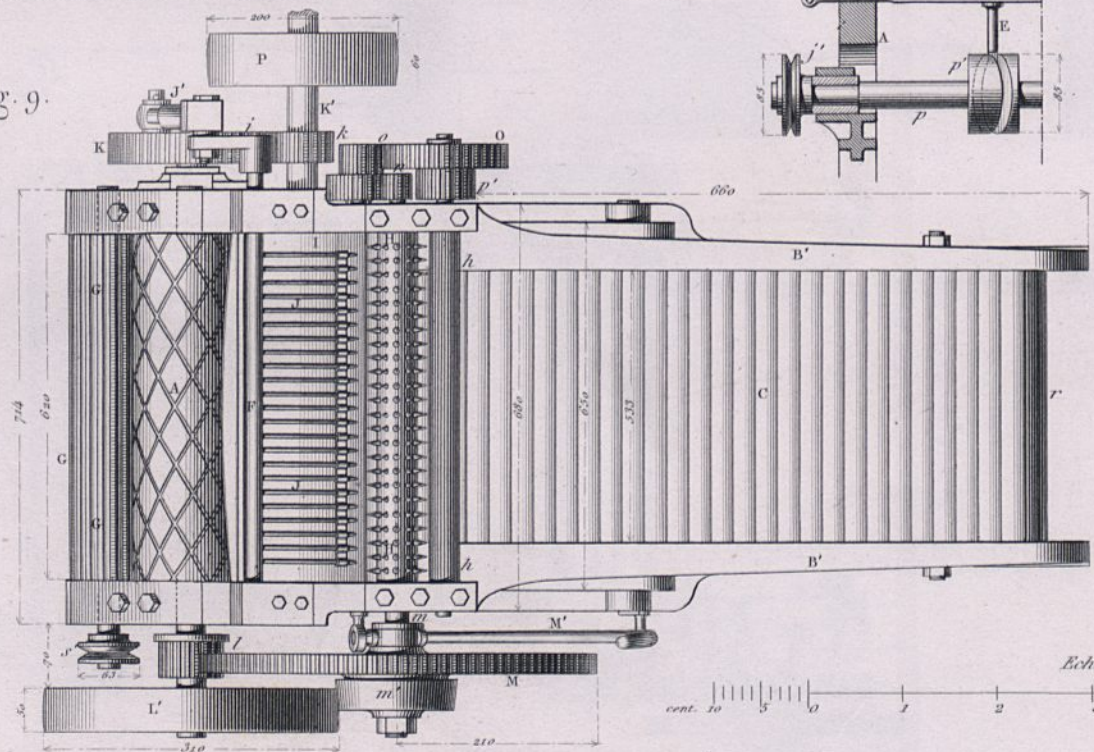


Fig. 11.

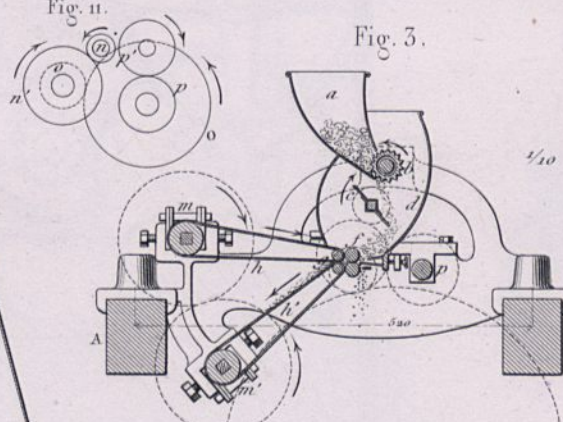


Fig. 3.

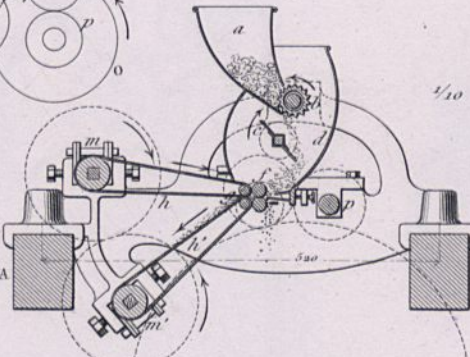
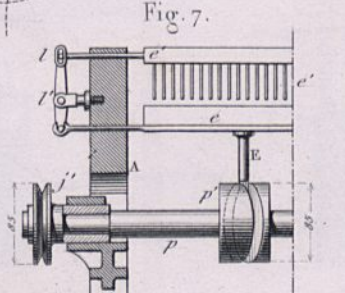


Fig. 7.



Roller-gin perfectionné par M. Chaufourier.

Fig. 4.

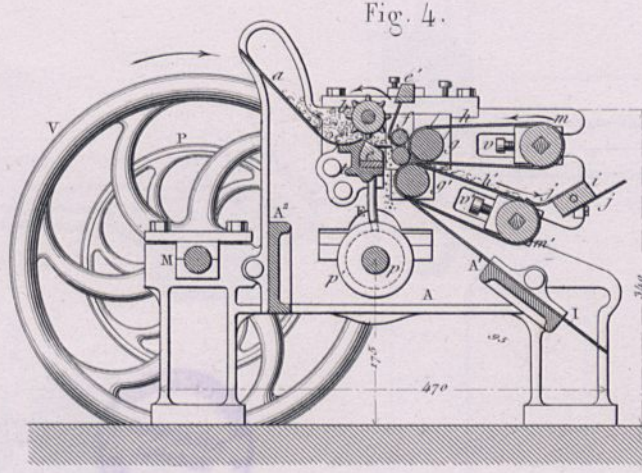
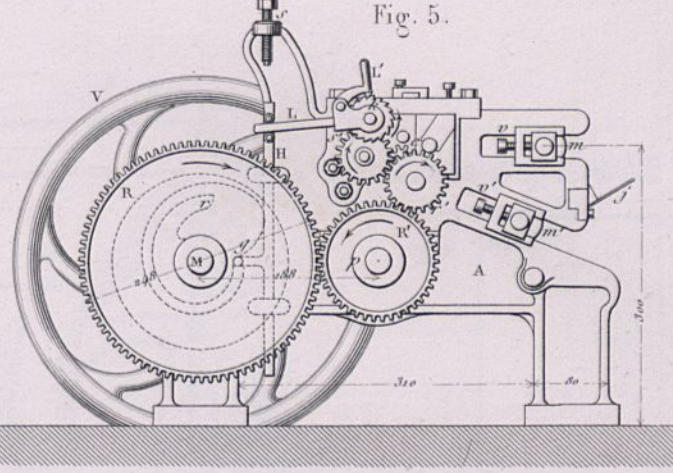


Fig. 5.



Mac Carthy-gin perfectionné par M. Loup.

Fig. 2.

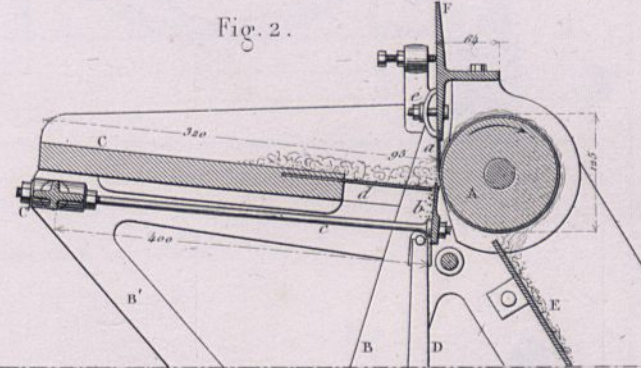
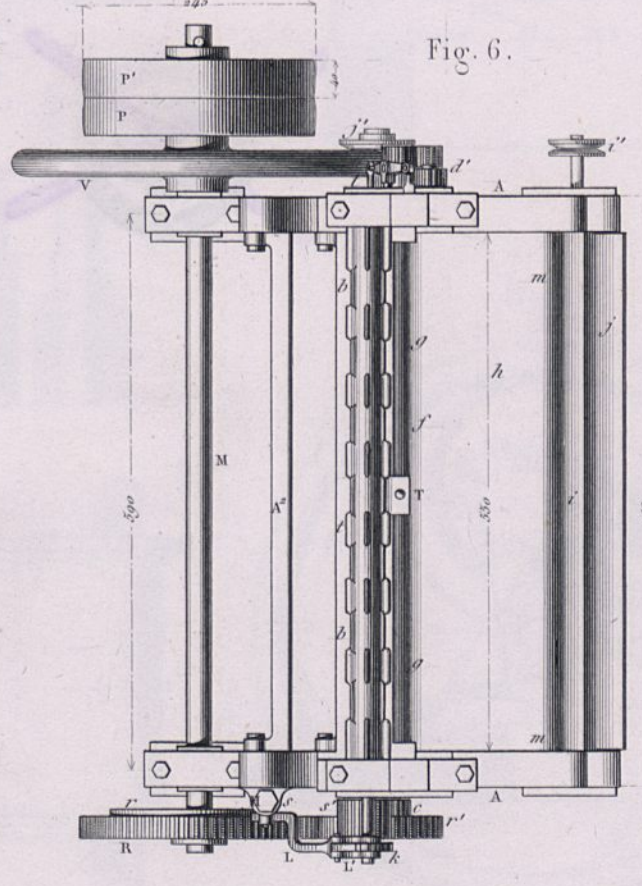
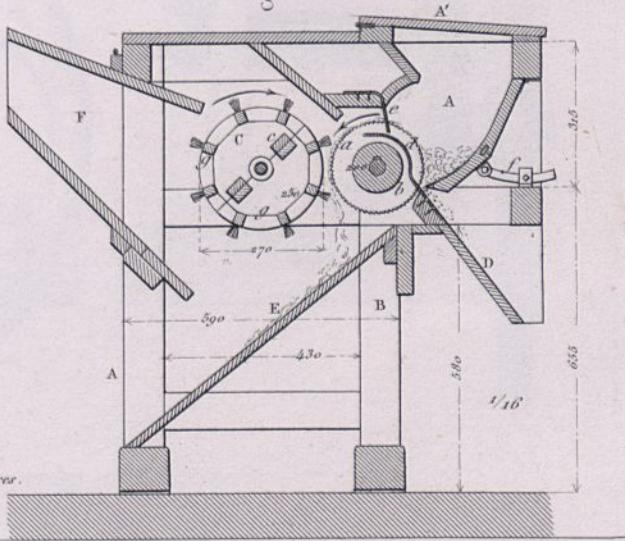


Fig. 6.



Saw-gin.

Fig. 1.

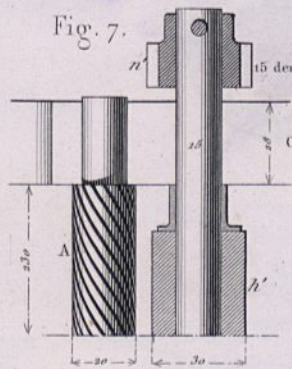
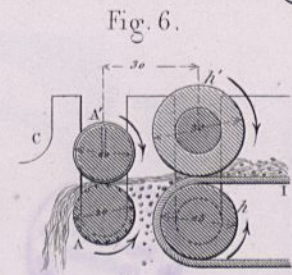
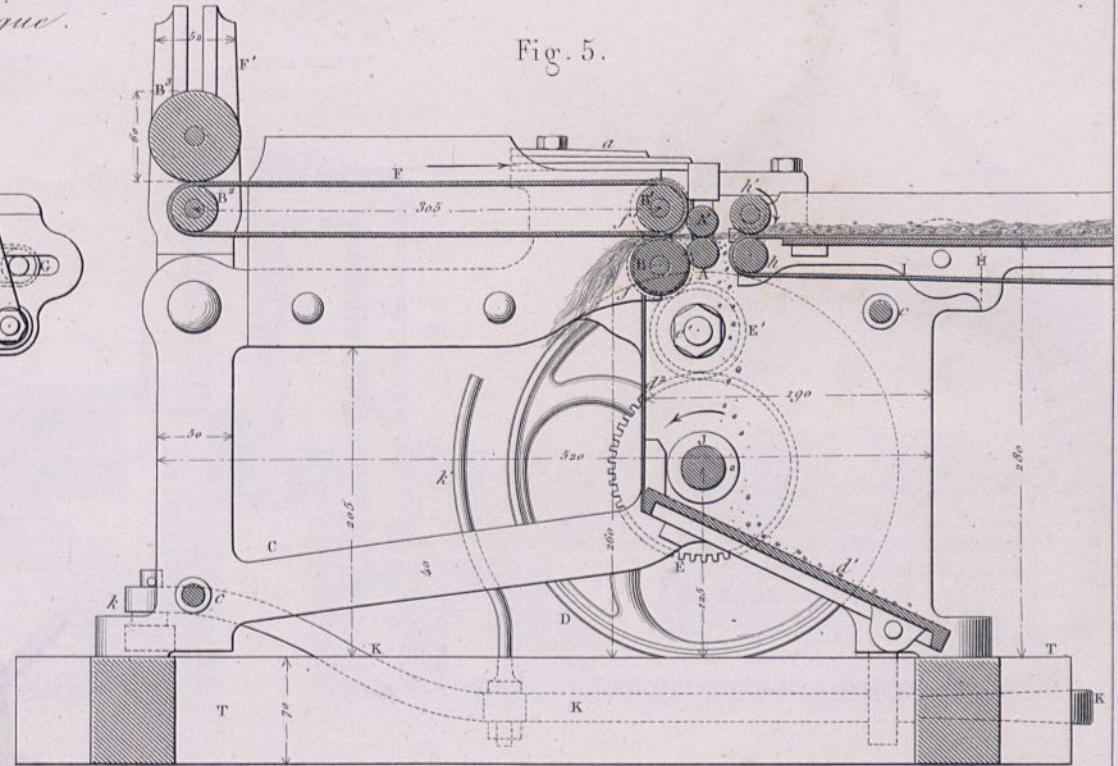
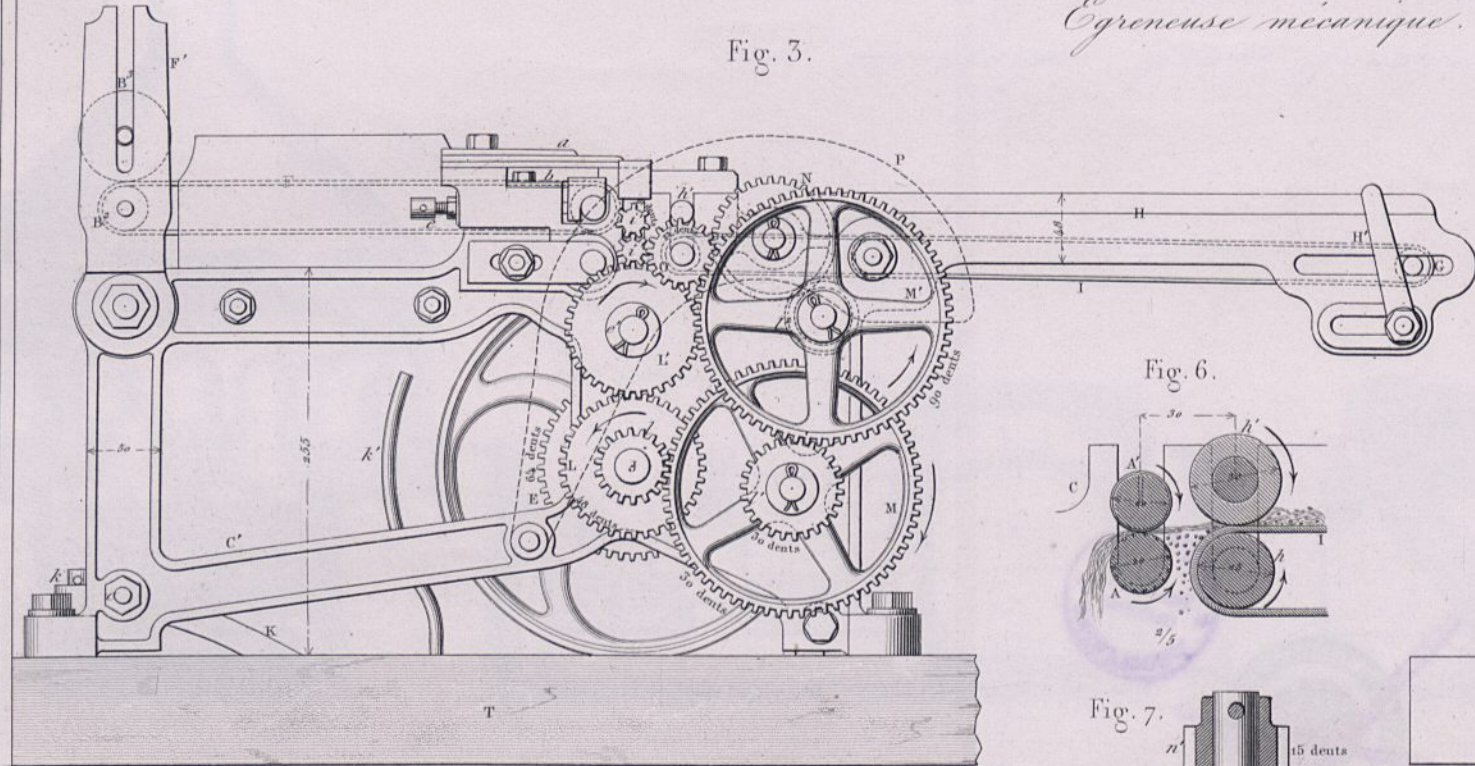


Echelle de 1/8 pour les Fig. 2, 4 à 10.

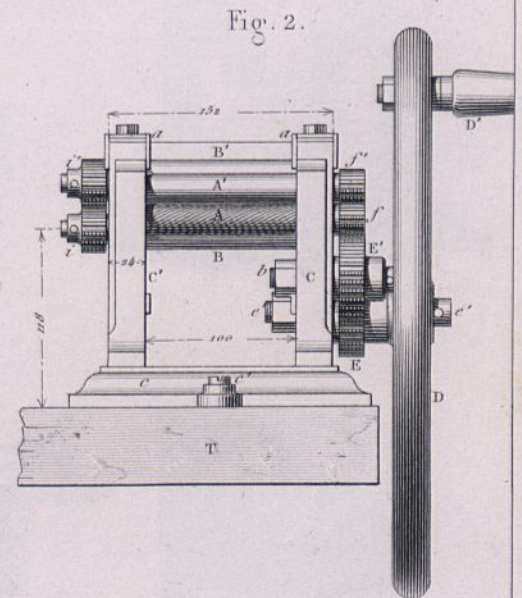
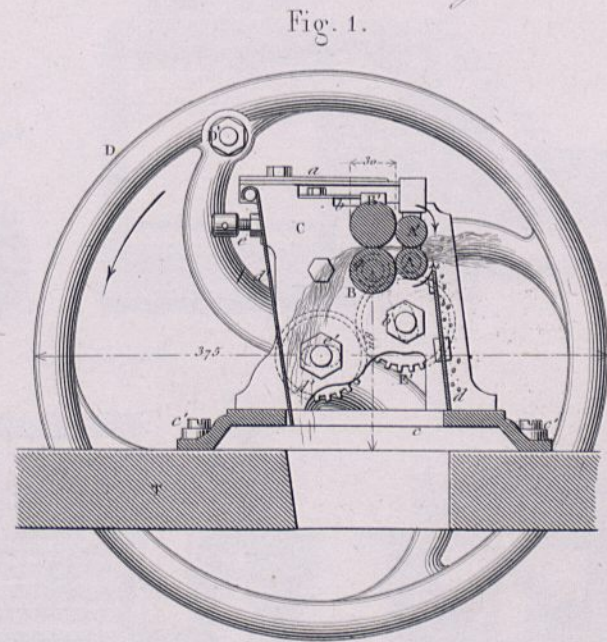
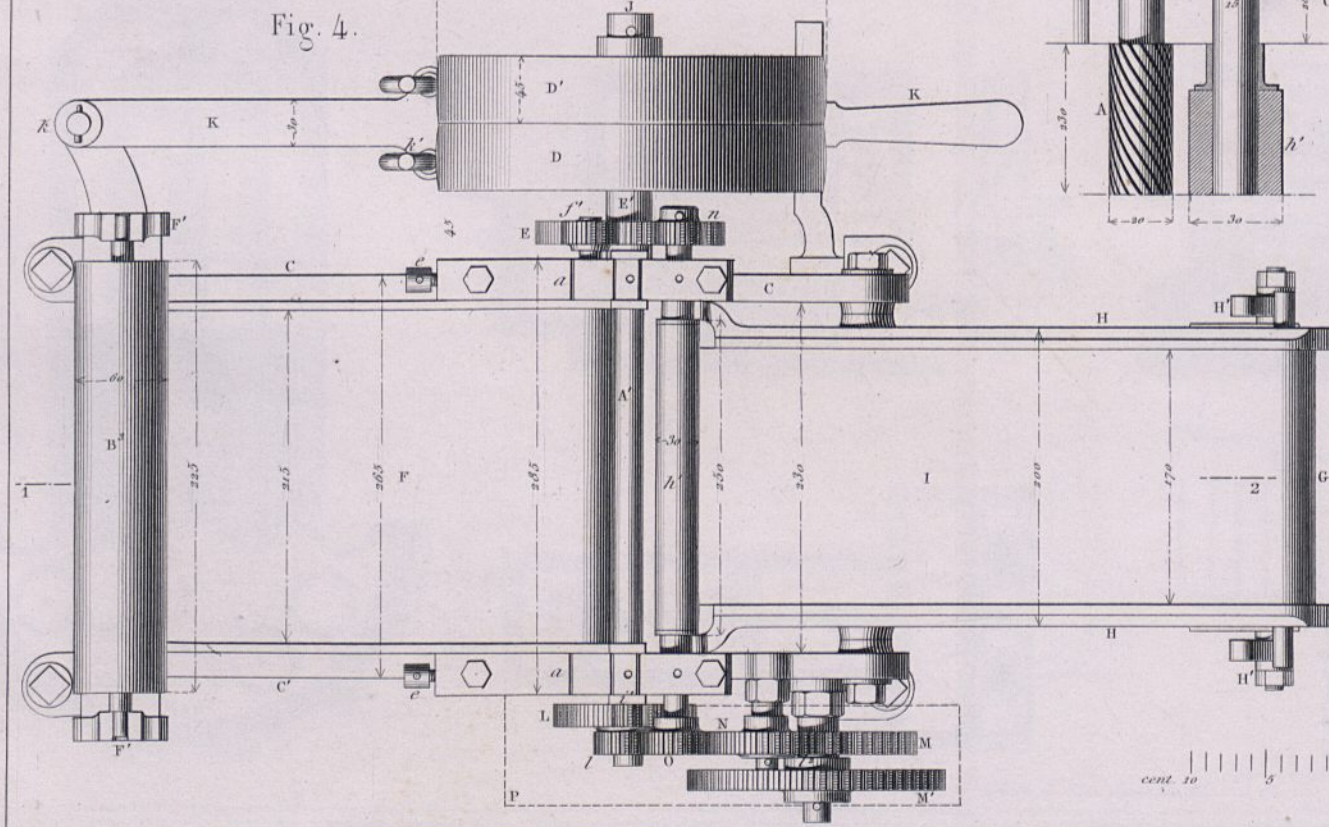
cent. 10 5 0 1 2 3 4 5 6 7 8 9 10 décimètres.



Egreneuse mécanique.



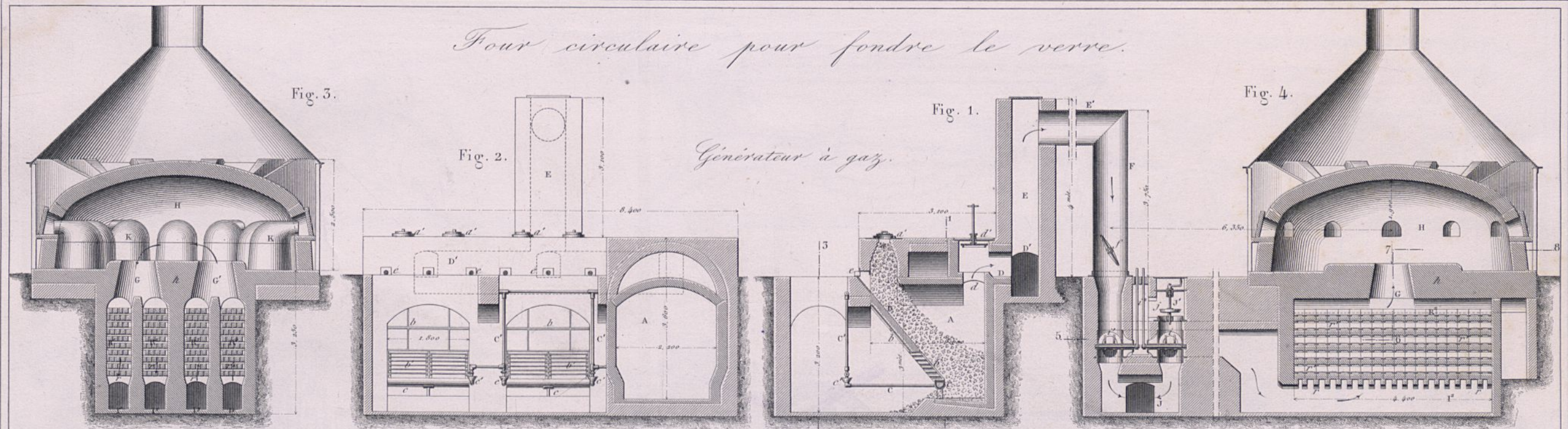
Egreneuse à bras.



Echelle de 1/5.
cent 10 5 0 1 2 3 4 5 6 décimètres.

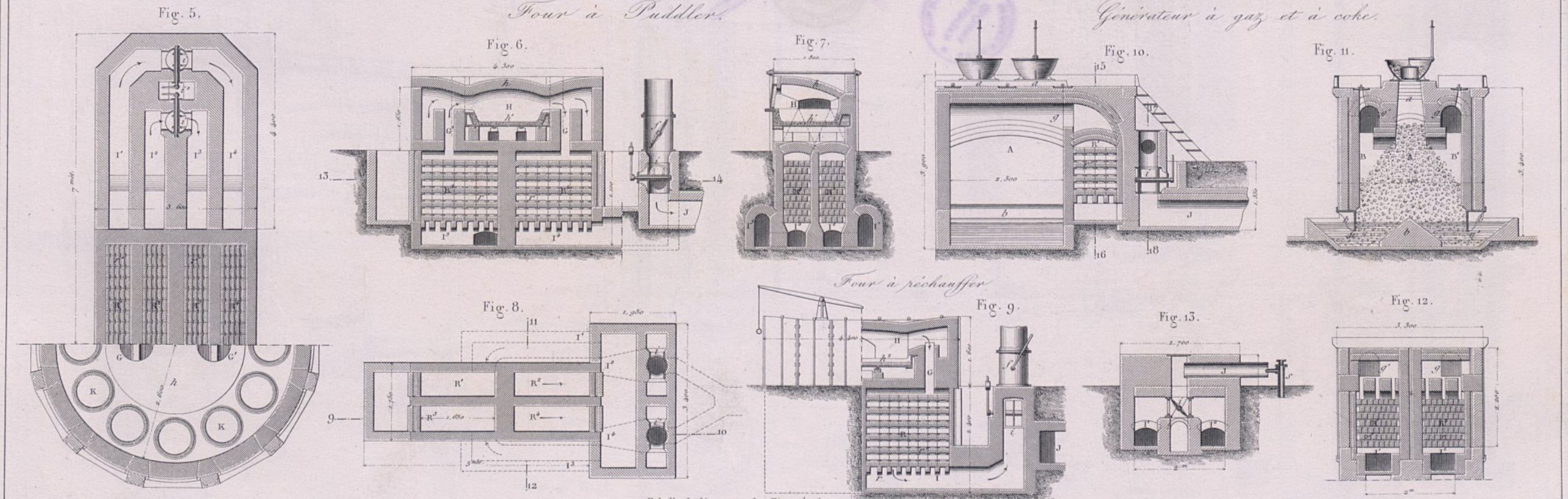


Four circulaire pour fondre le verre.



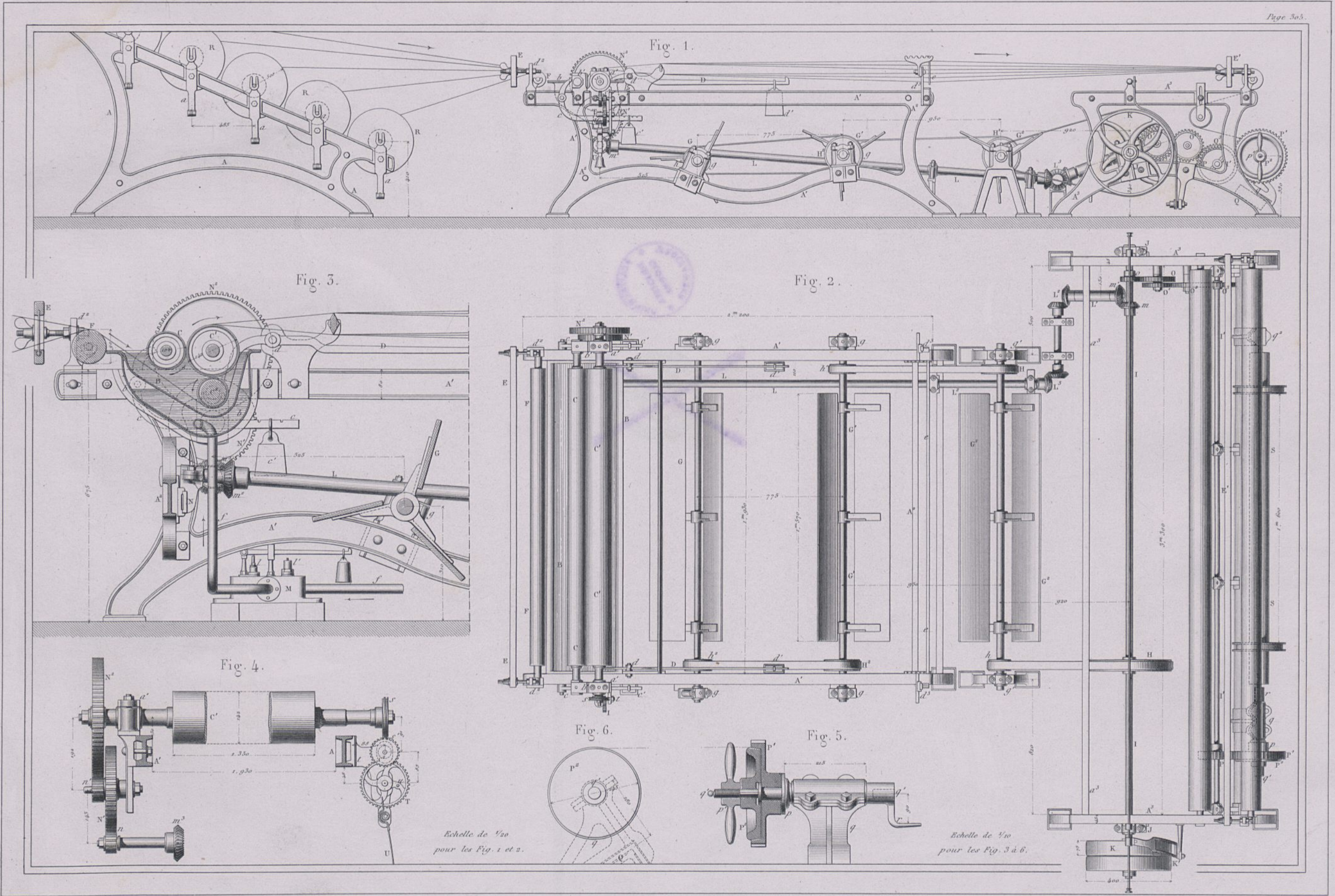
Four à Puddler.

Générateur à gaz et à coke.



Echelle de 1/100 pour les Fig. 1 à 13.

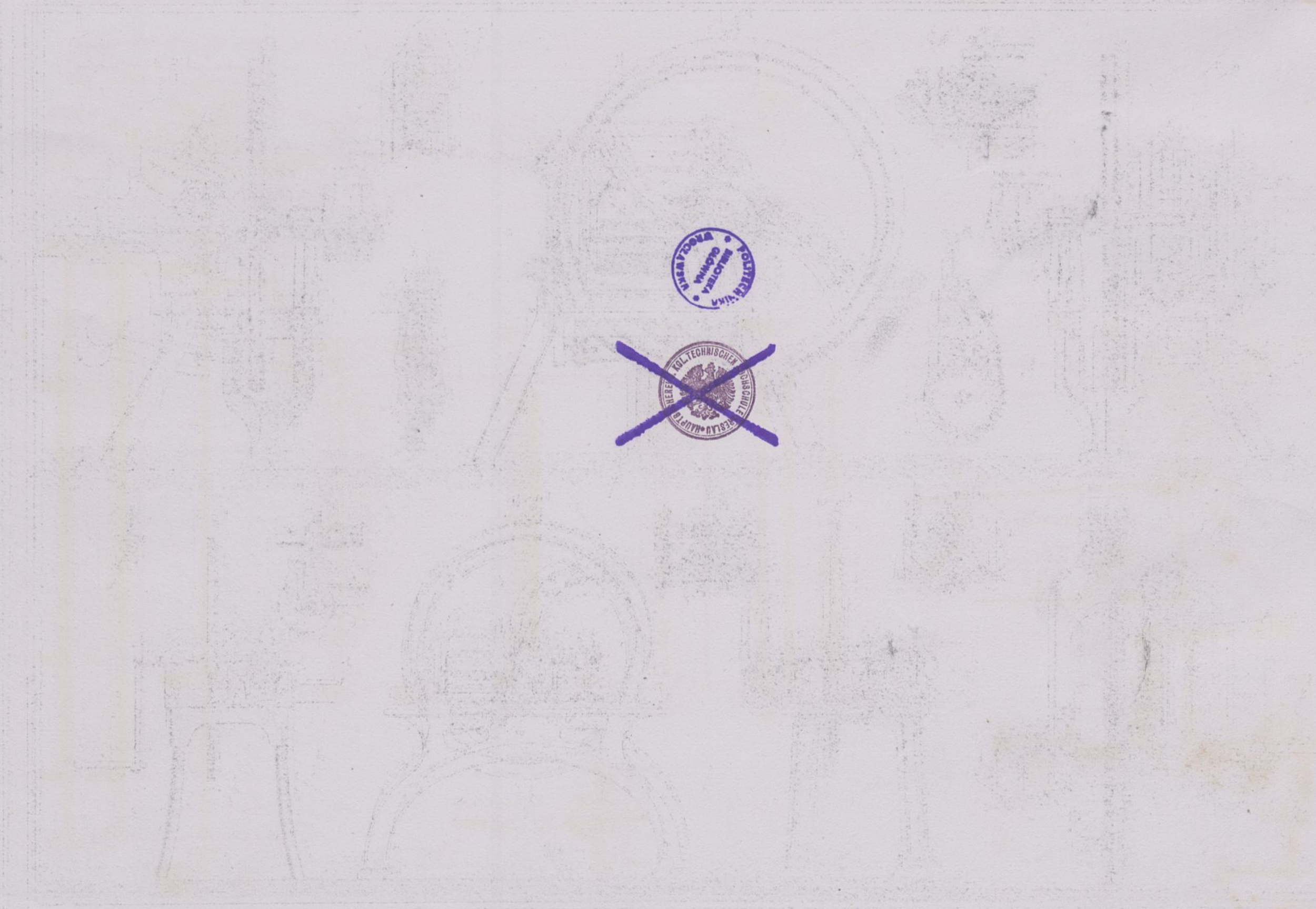


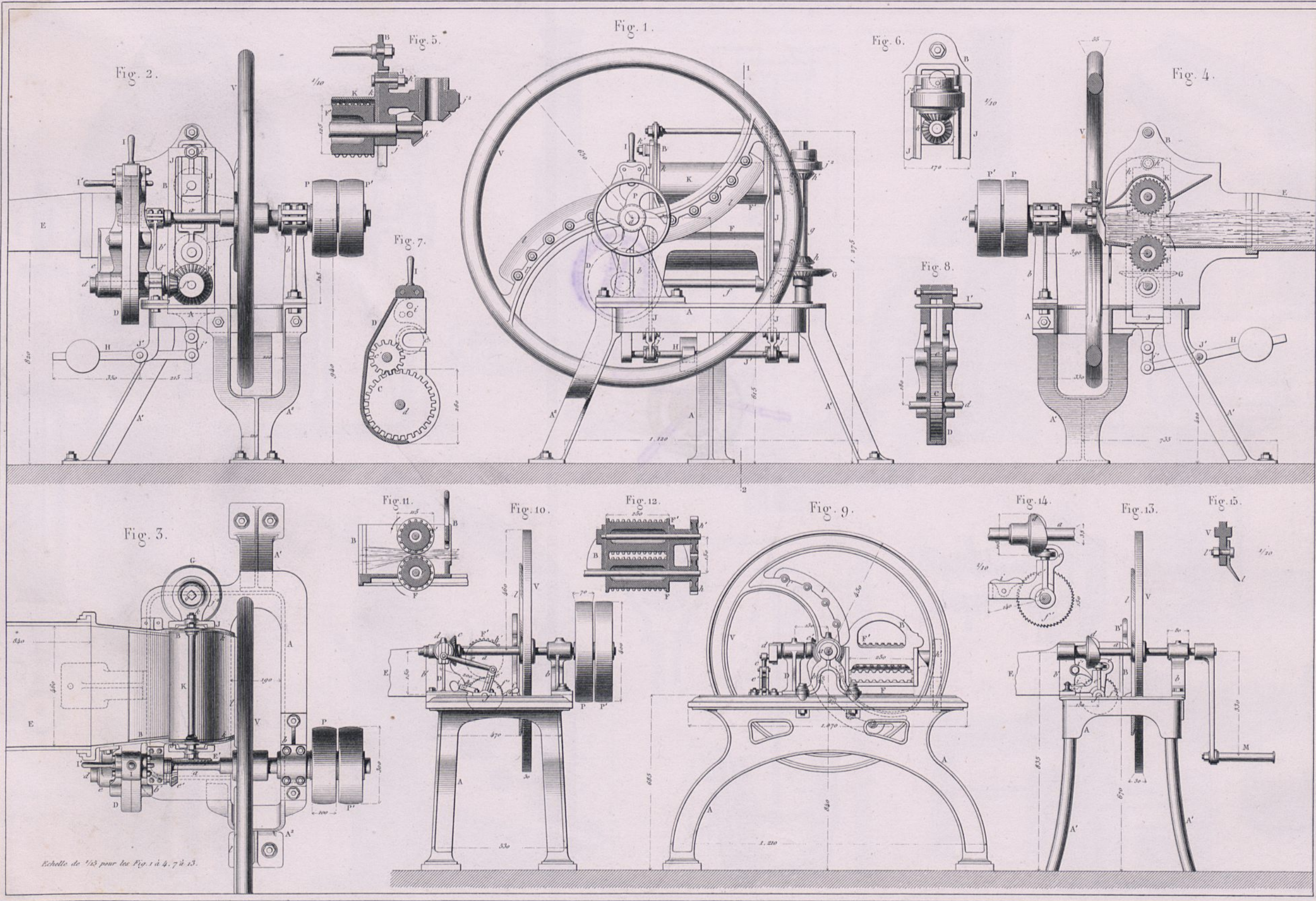


Echelle de 1/50 pour les Fig. 1 et 2.

Echelle de 1/50 pour les Fig. 3 à 6.

UNIVERSITY OF TORONTO LIBRARY
130 St. George Street, Toronto, Ontario M5S 1A5

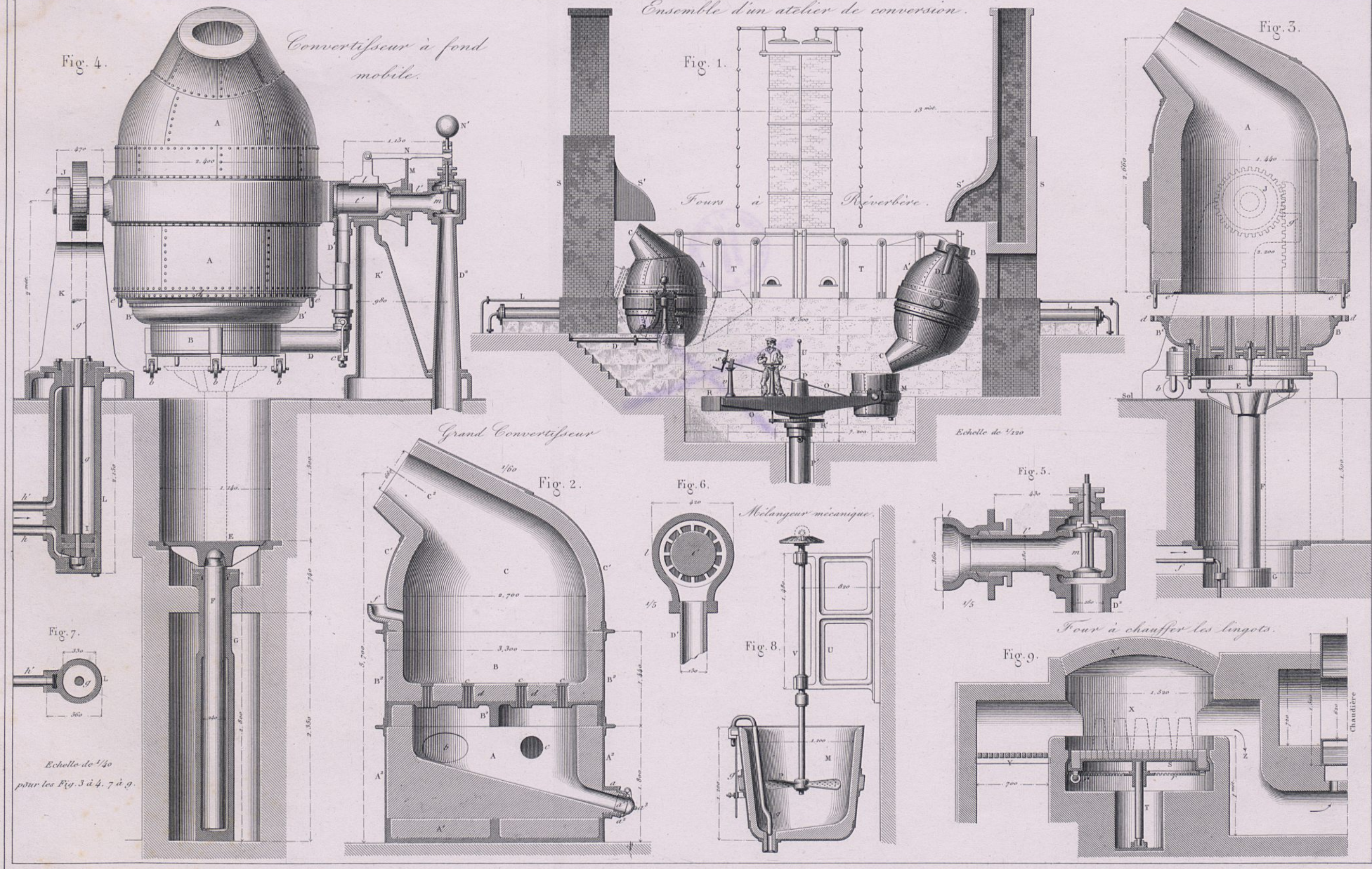




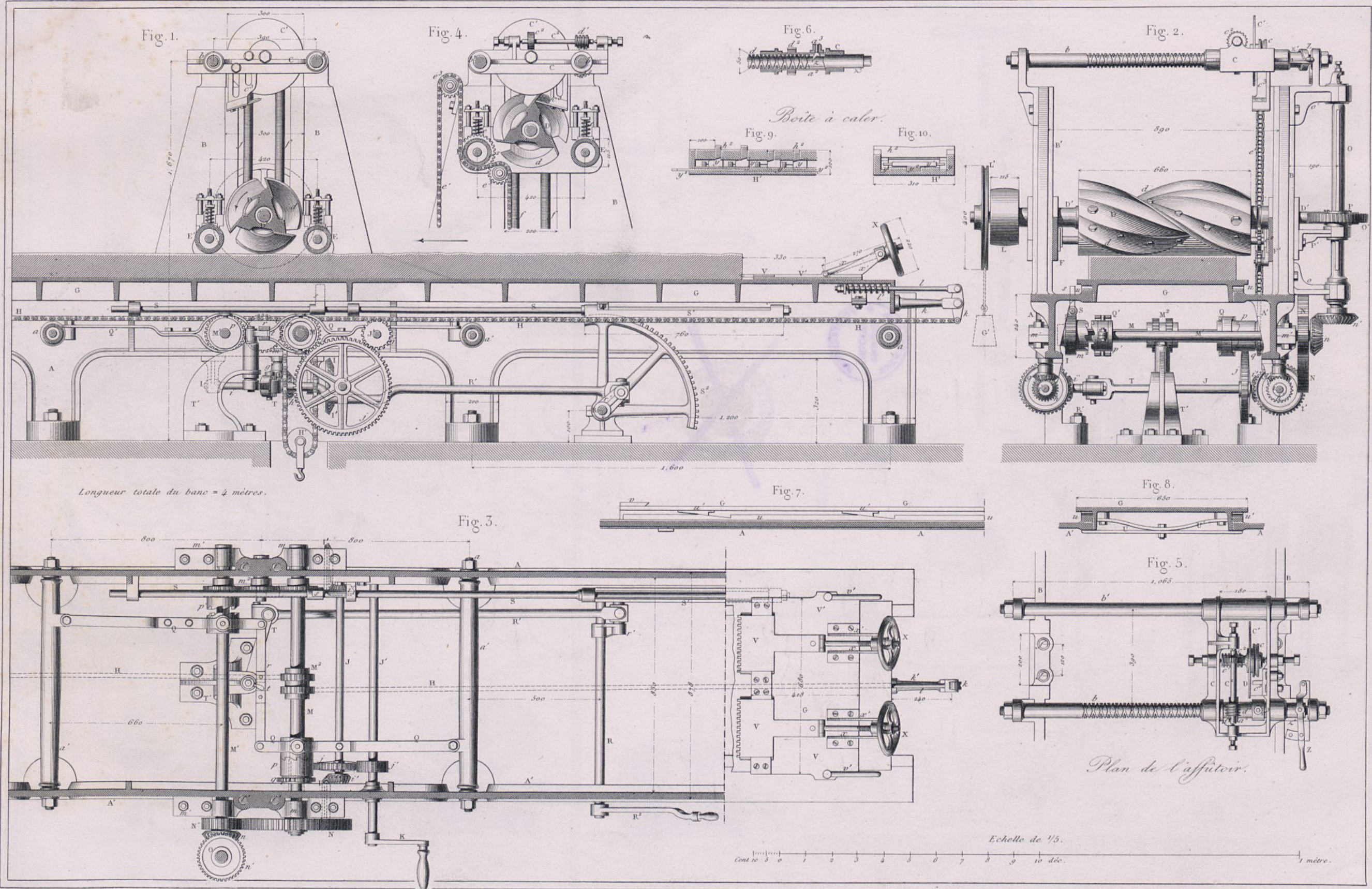
Echelle de 1/15 pour les Fig. 1 à 4, 7 à 13.



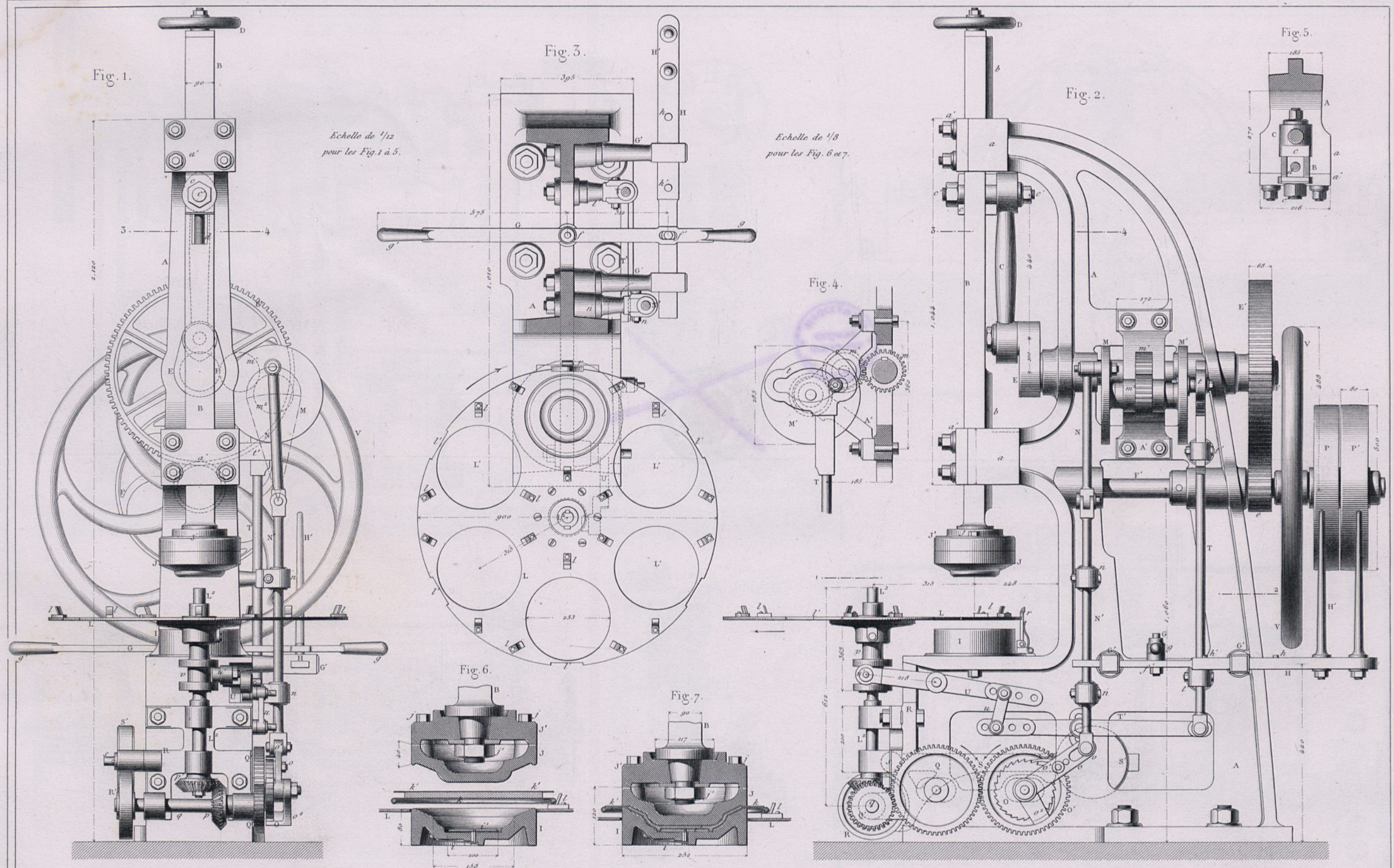
Ensemble d'un atelier de conversion.



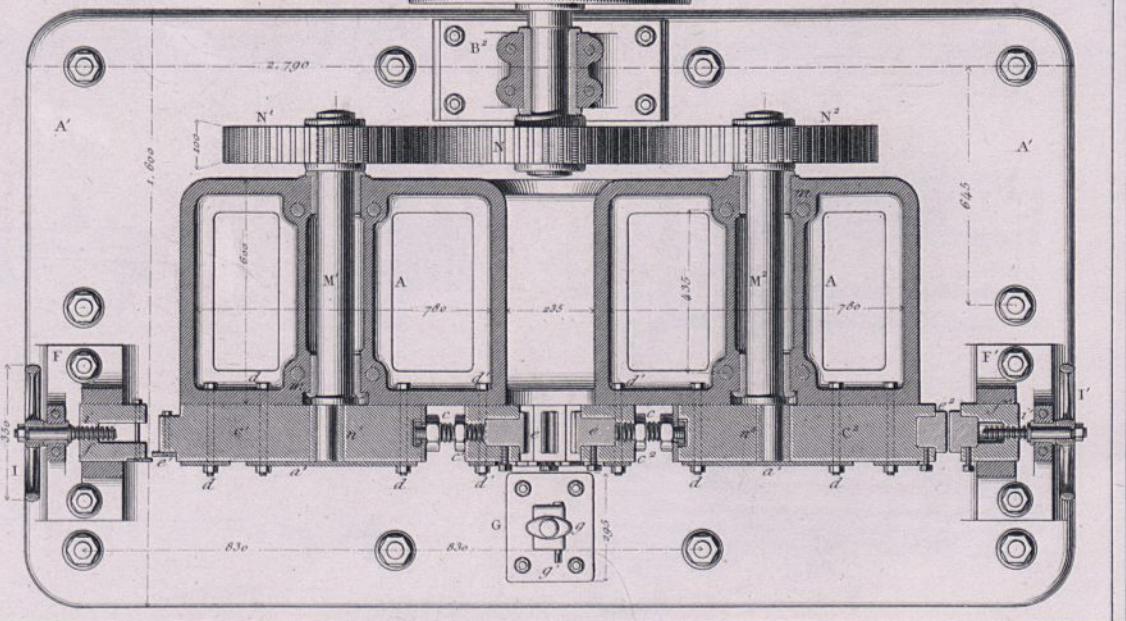
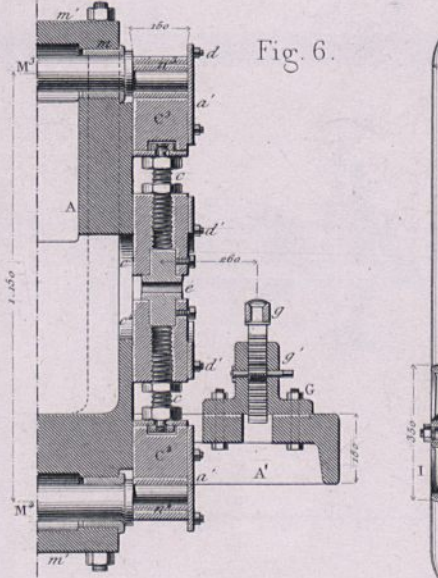
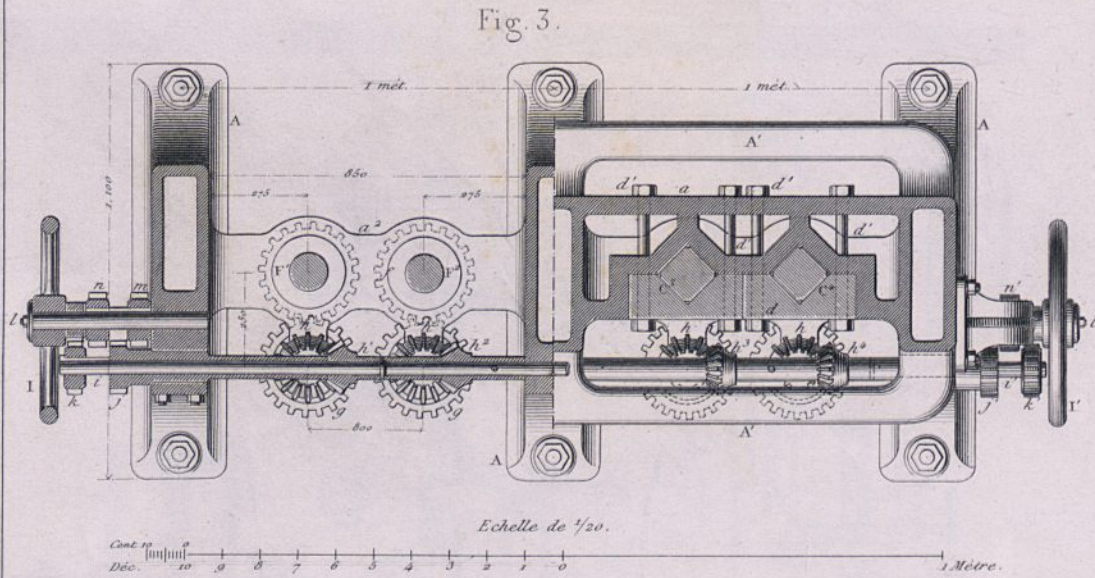
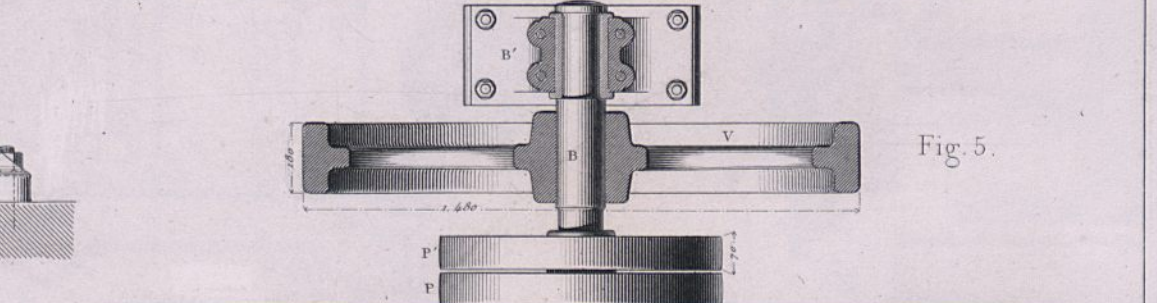
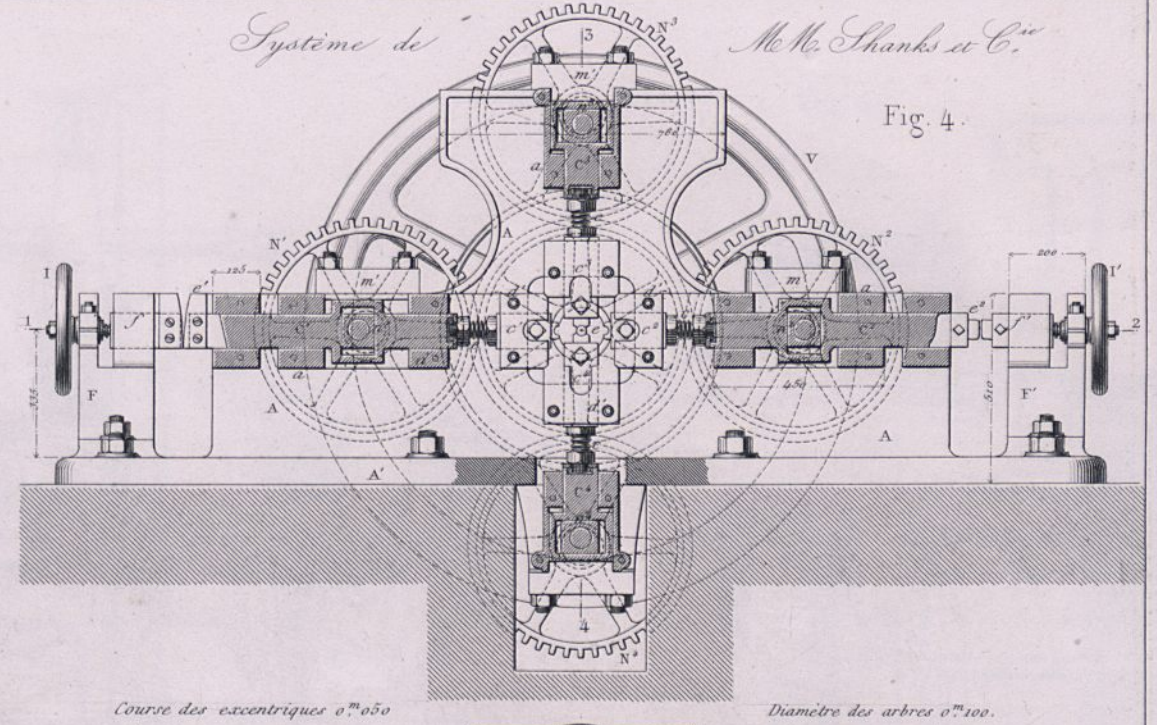
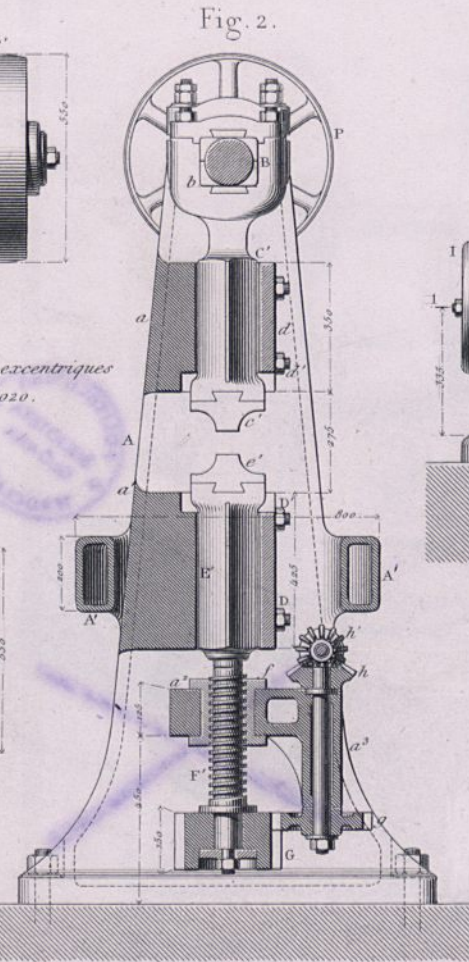
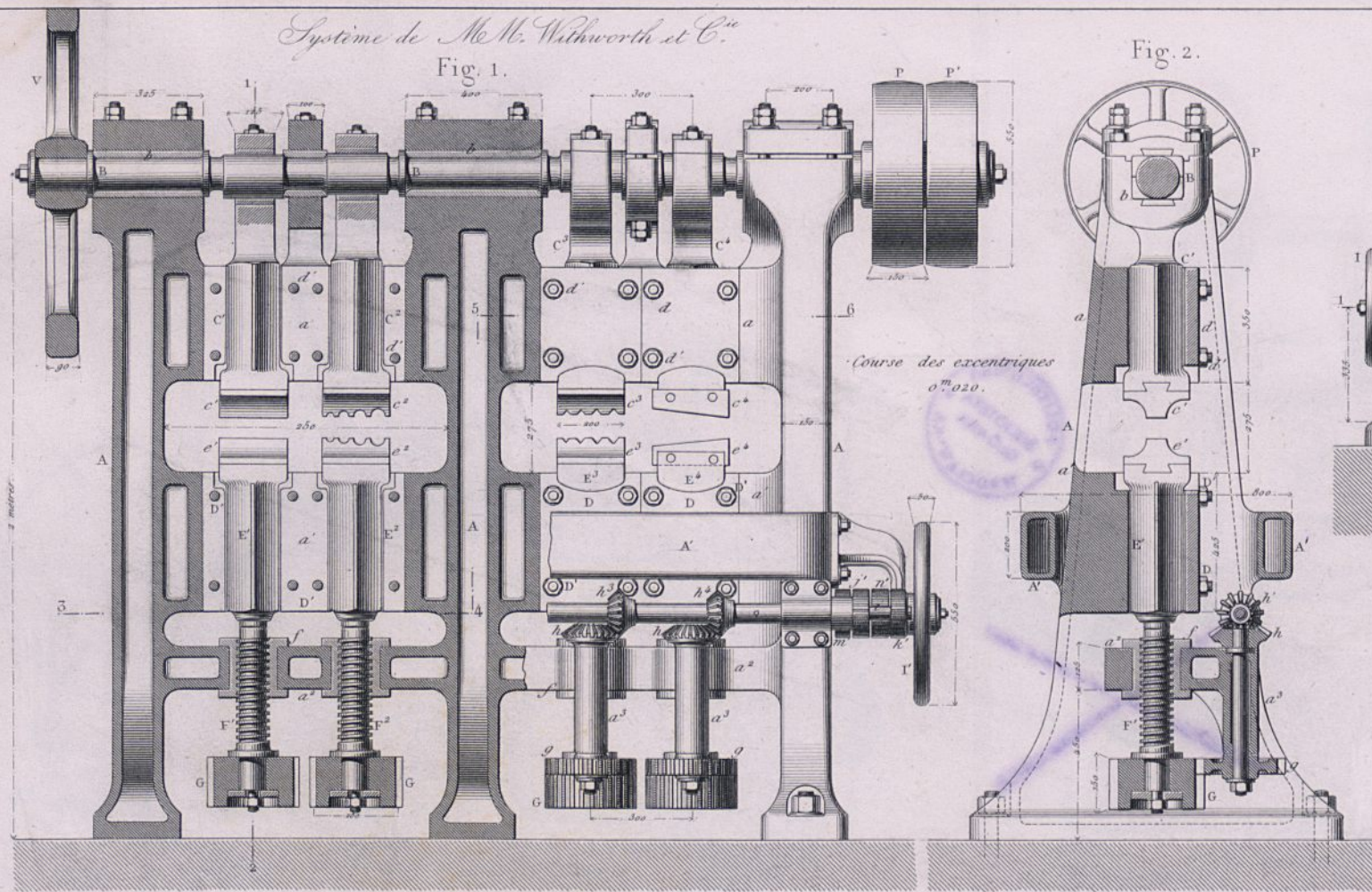














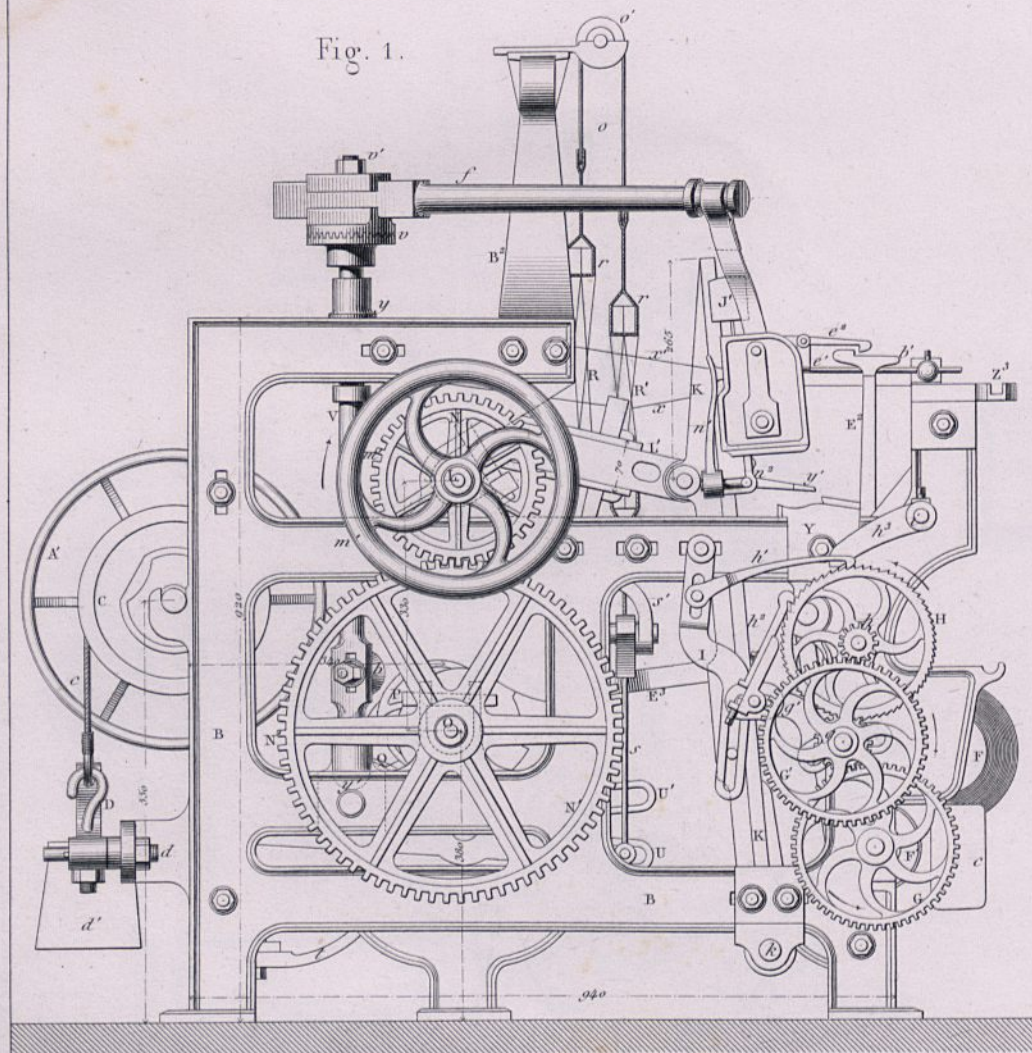


Fig. 1.

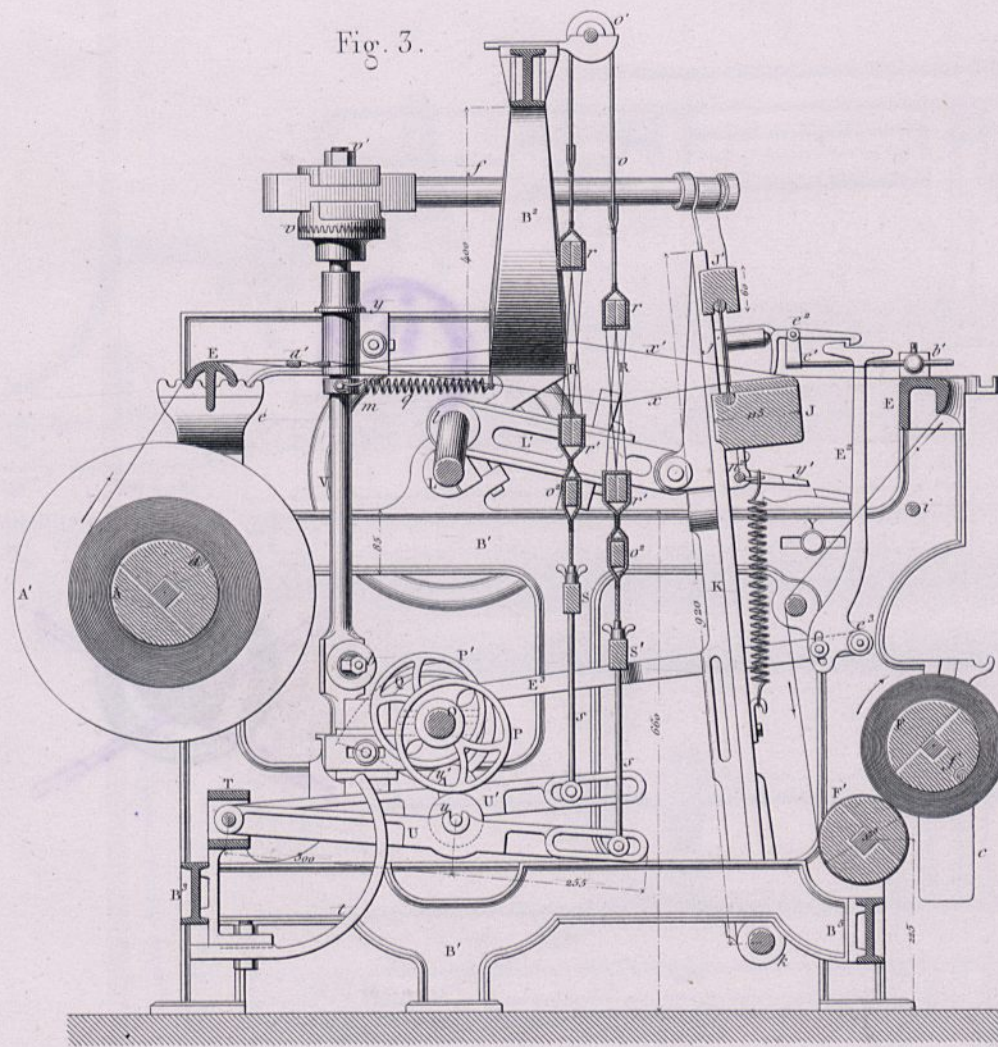


Fig. 3.

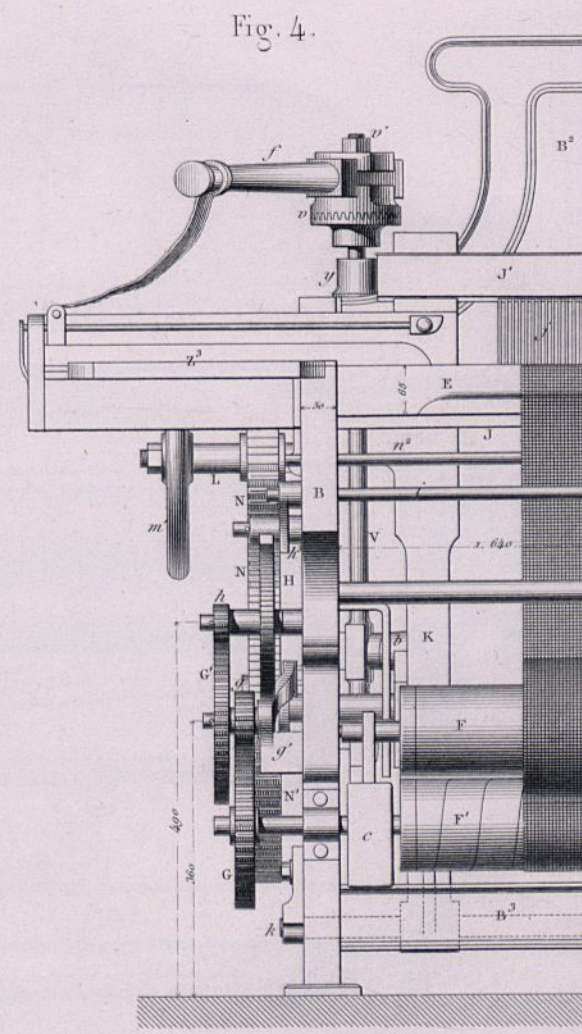


Fig. 4.

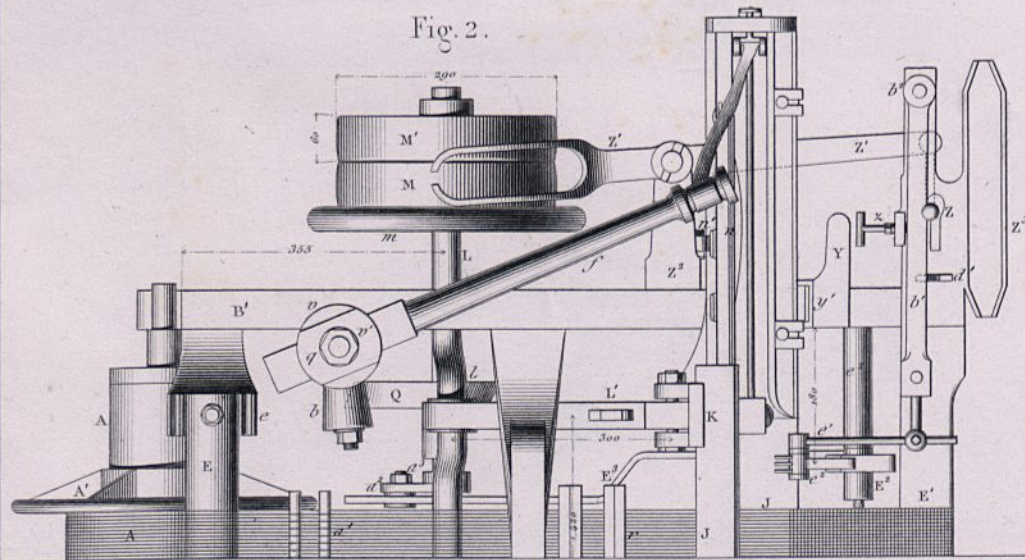


Fig. 2.

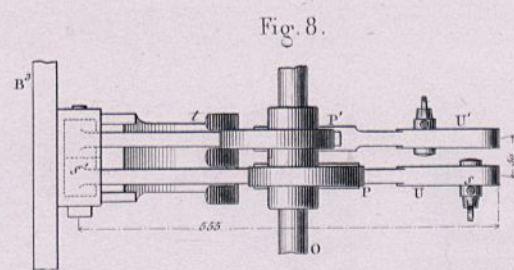


Fig. 8.

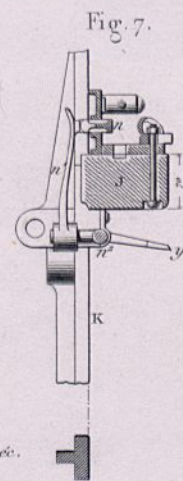


Fig. 7.

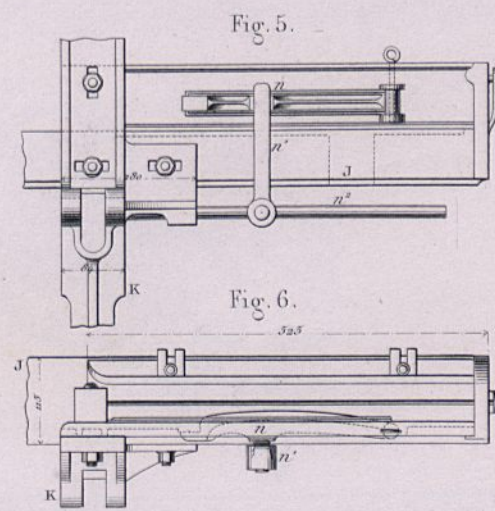
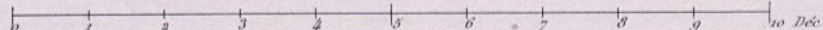


Fig. 5.

Fig. 6.

Echelle de 1/10.



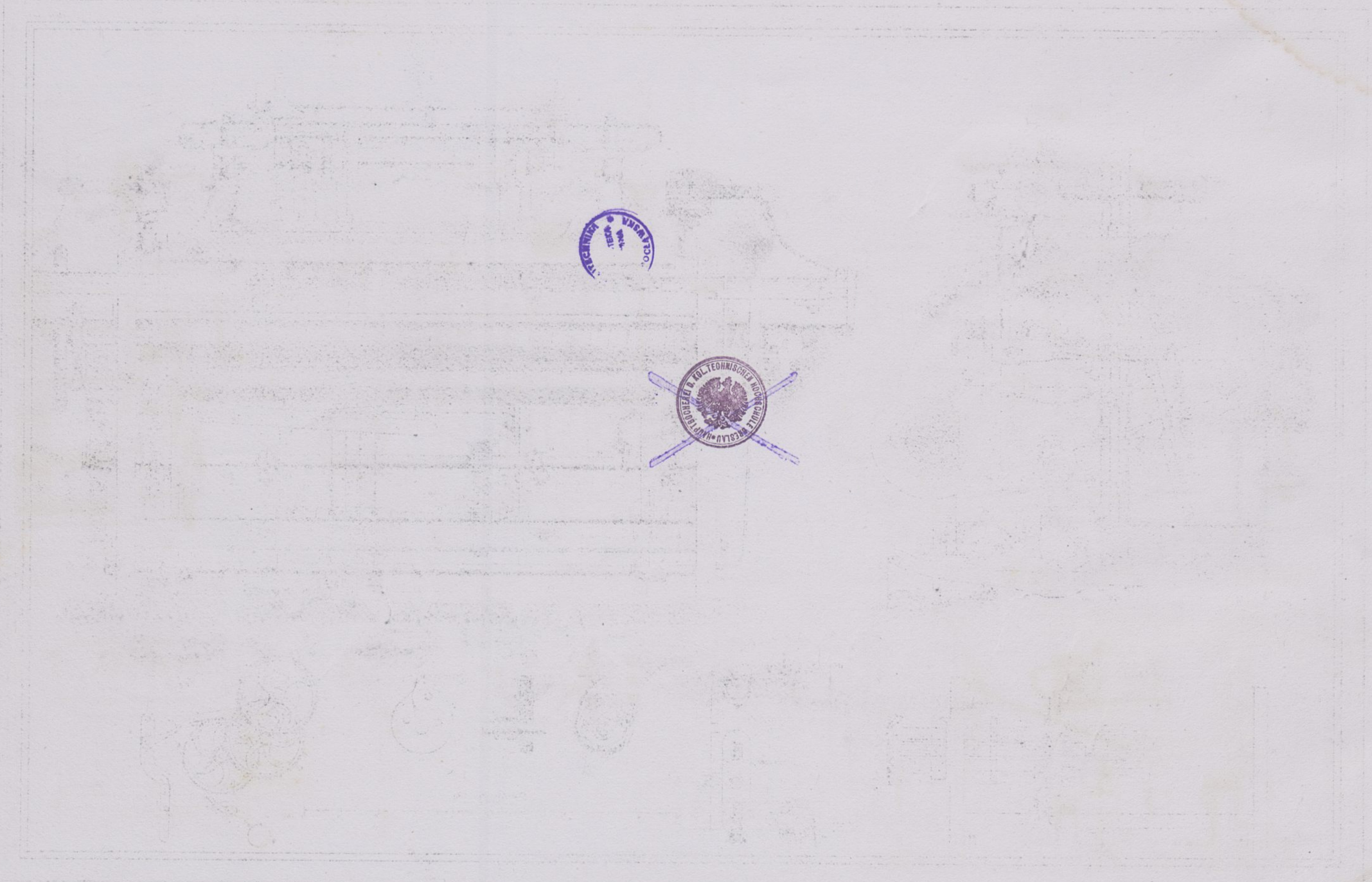


Fig. 2.

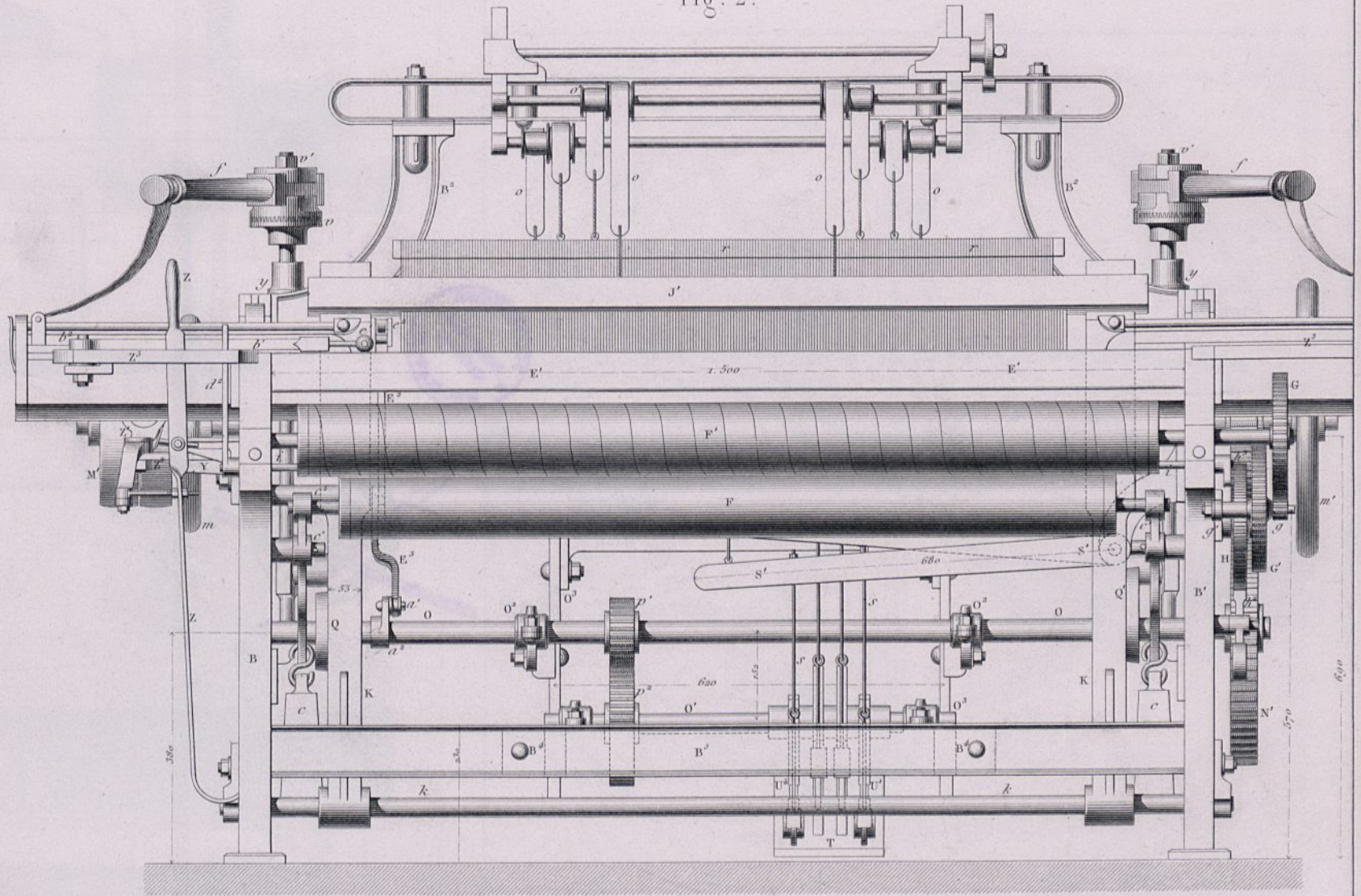


Fig. 1.

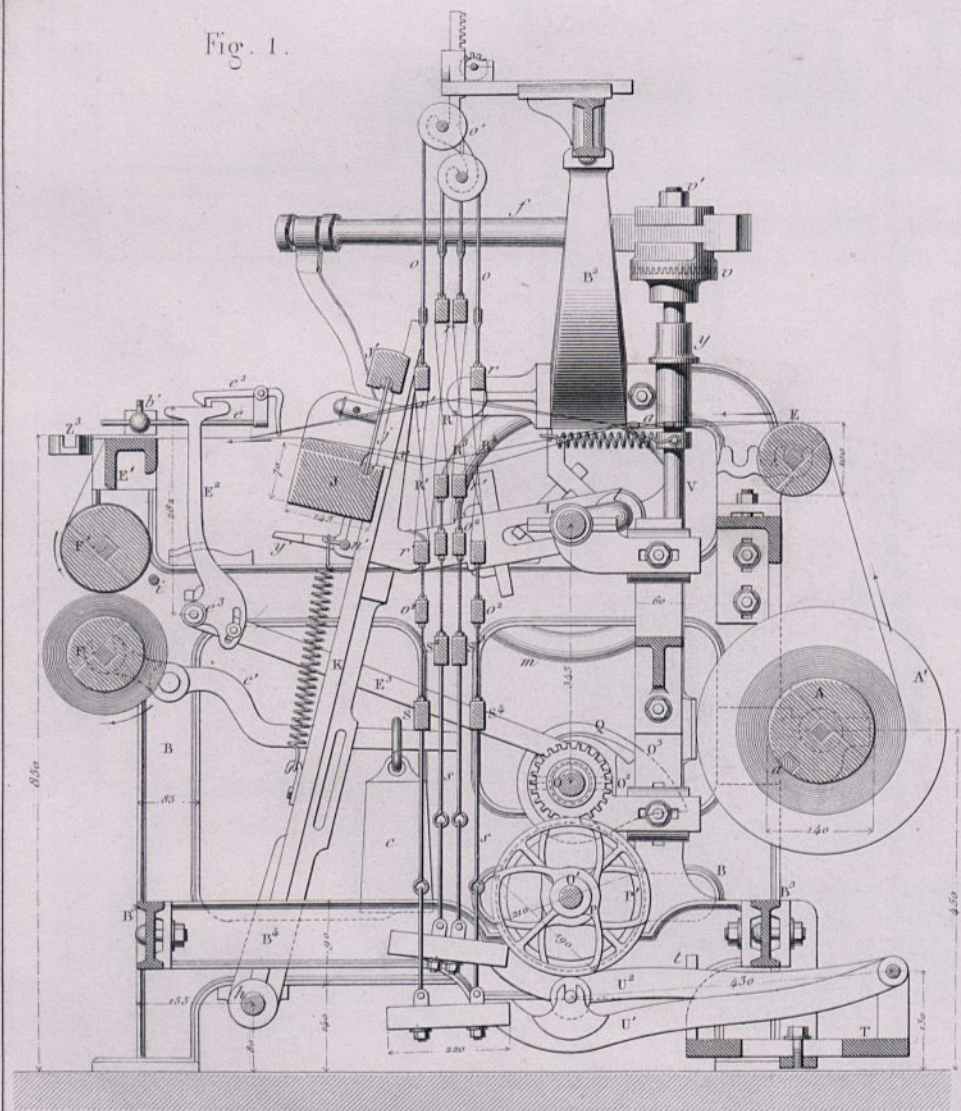


Fig. 3.

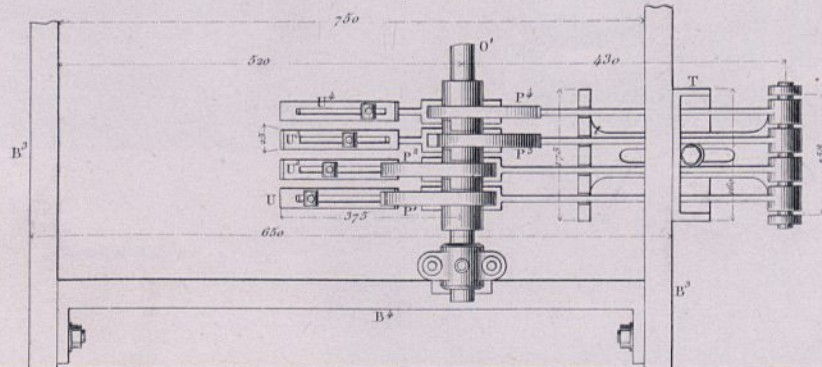


Fig. 6.

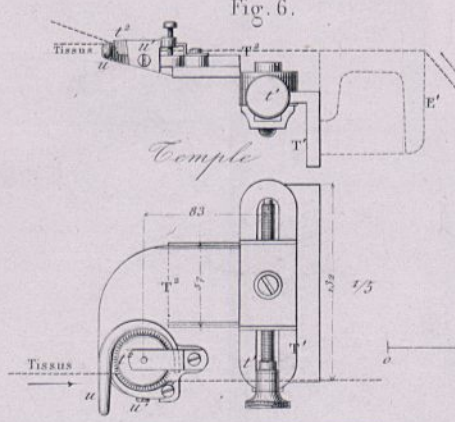
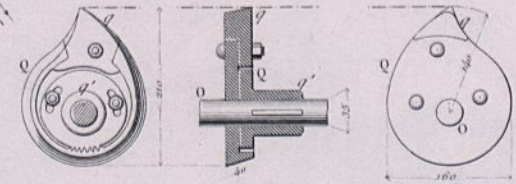
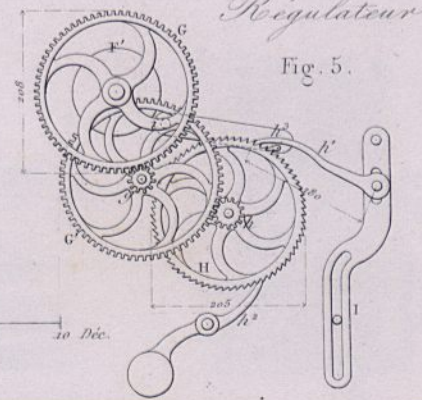


Fig. 4.



Régulateur

Fig. 5.



Echelle de 1/10.

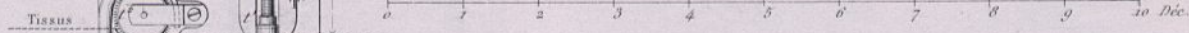




Fig. 1.

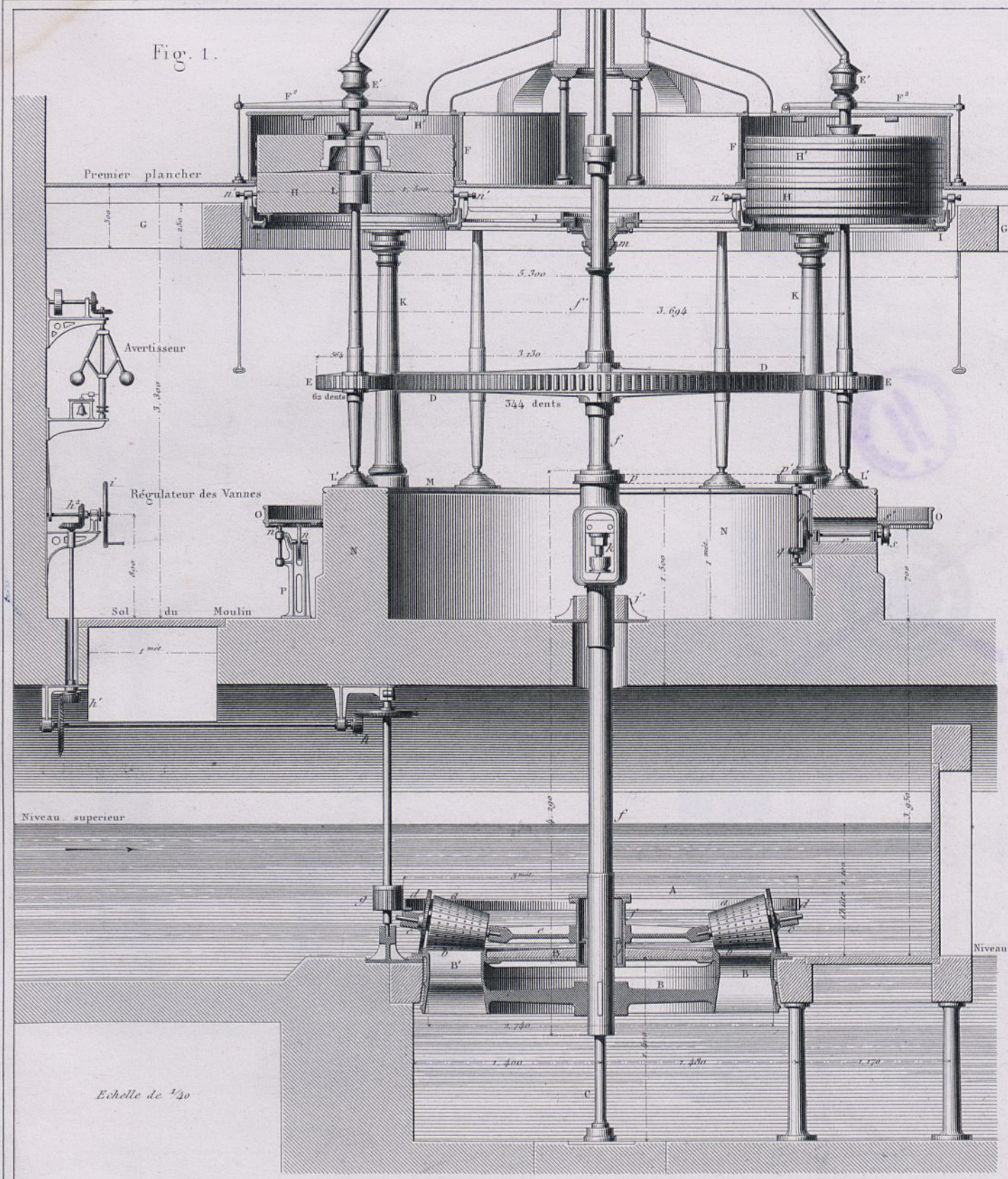


Fig. 2.

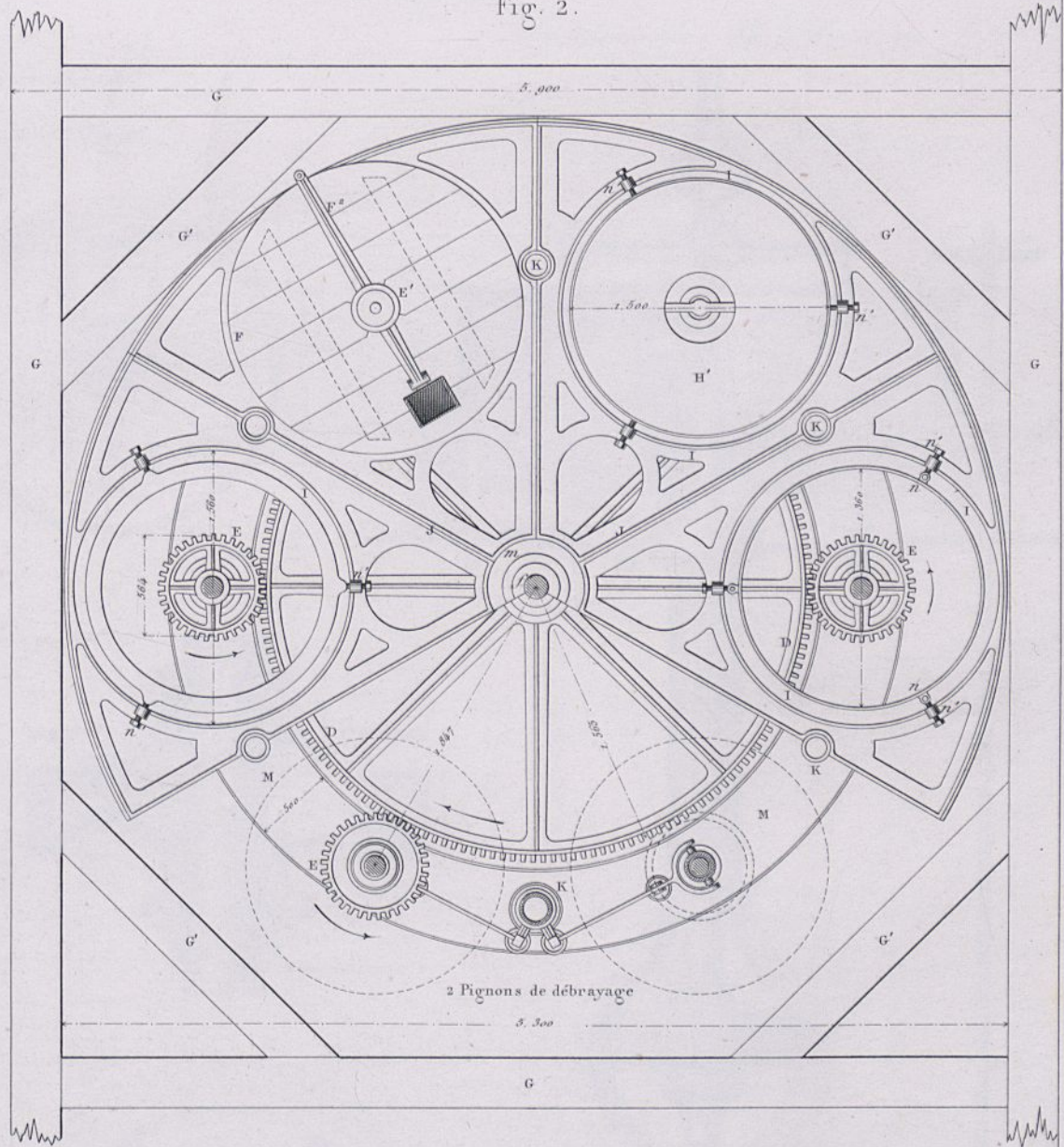


Fig. 3.

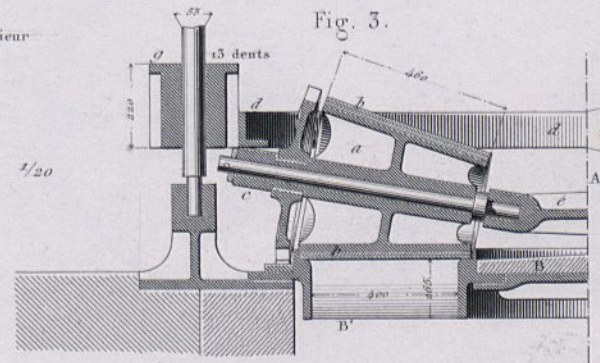
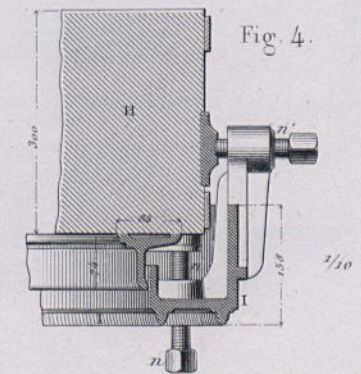


Fig. 4.





Système de M. Mauzaige.

Système de M. Christian.

Fig. 1.

Pignon conique débrayant.

Fig. 5.

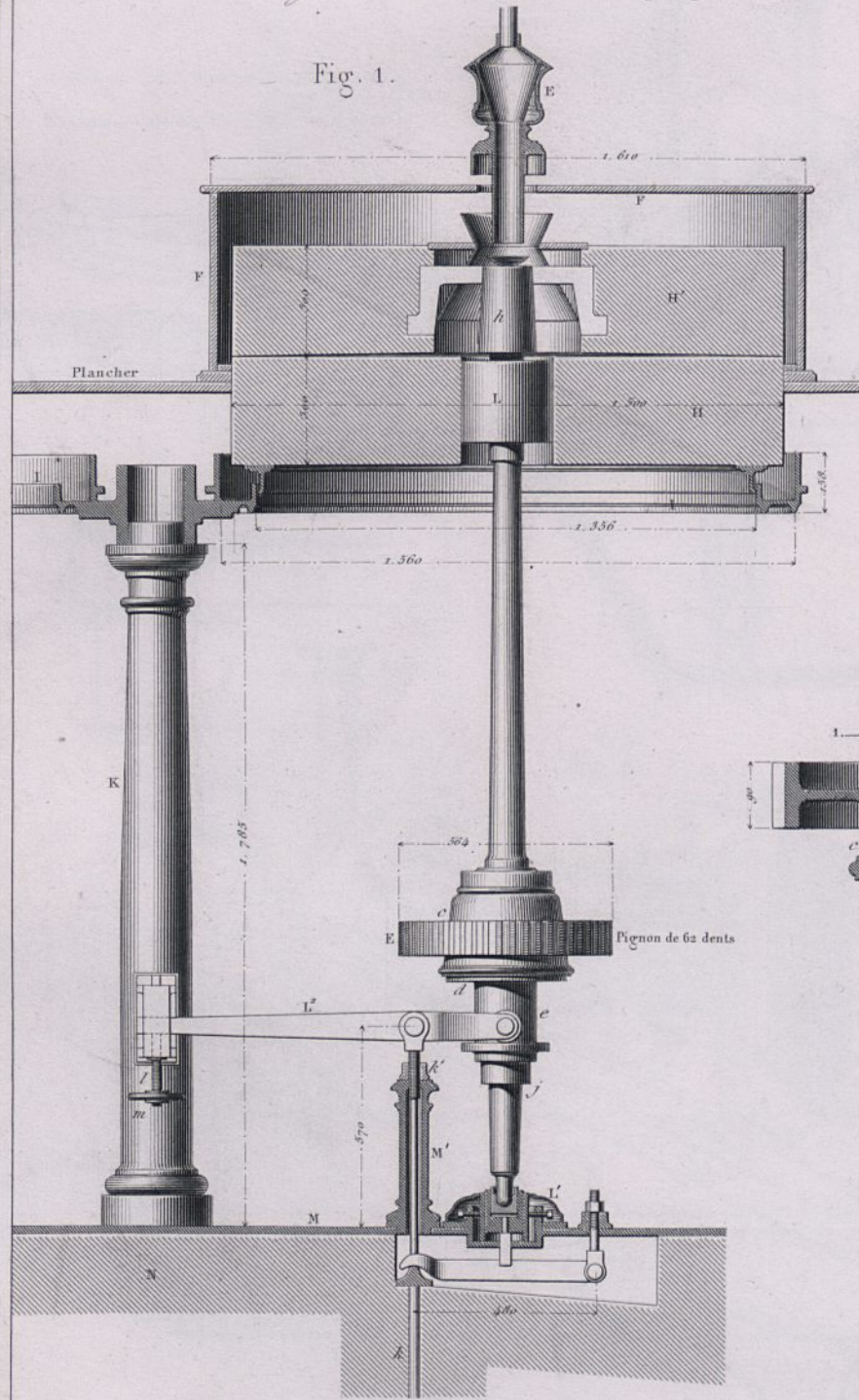


Fig. 9.

Fig. 10.

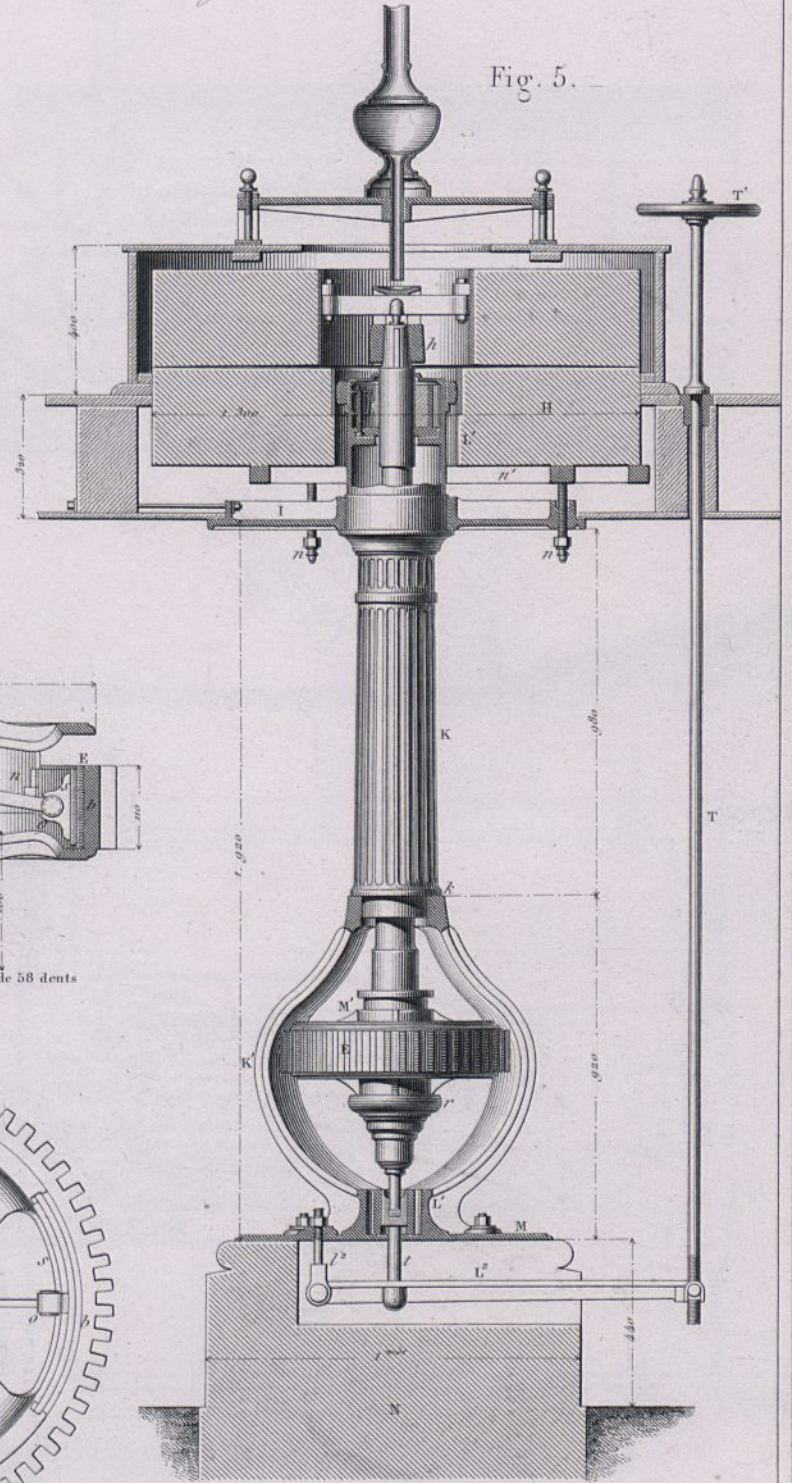
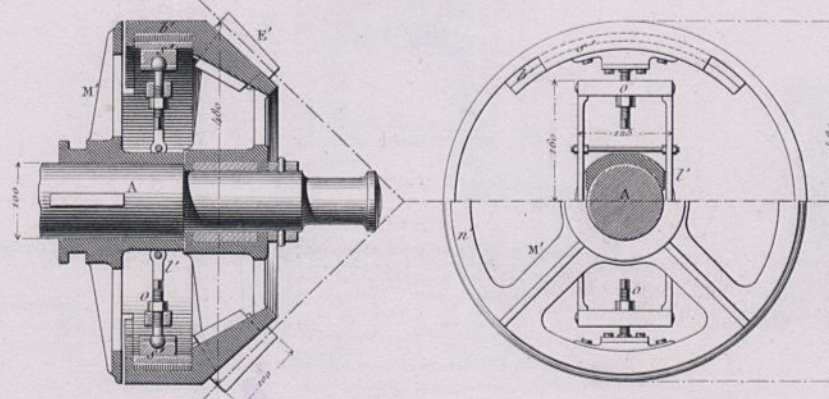


Fig. 2.

Fig. 6.

Pignons droits débrayant.

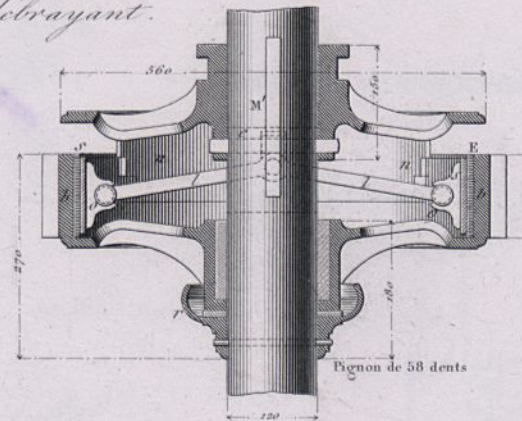
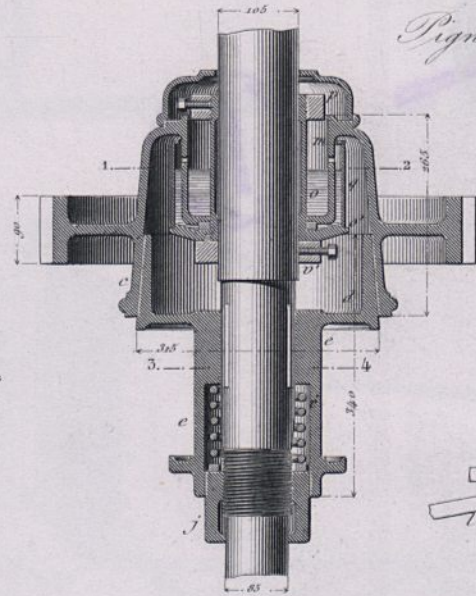


Fig. 8.

Fig. 7.

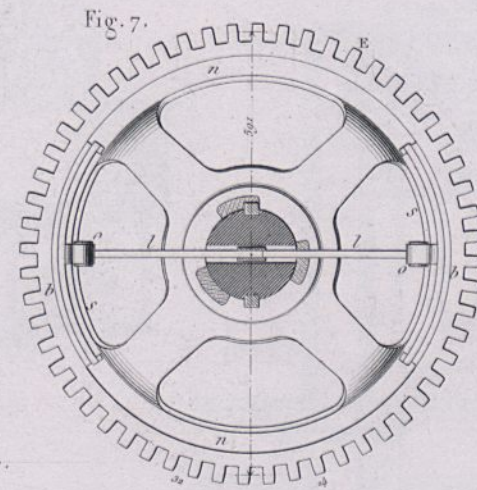
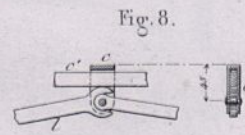
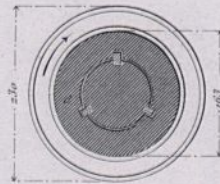
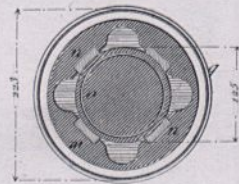


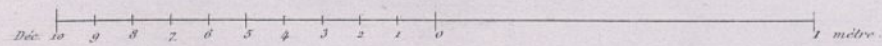
Fig. 3.

Fig. 4.

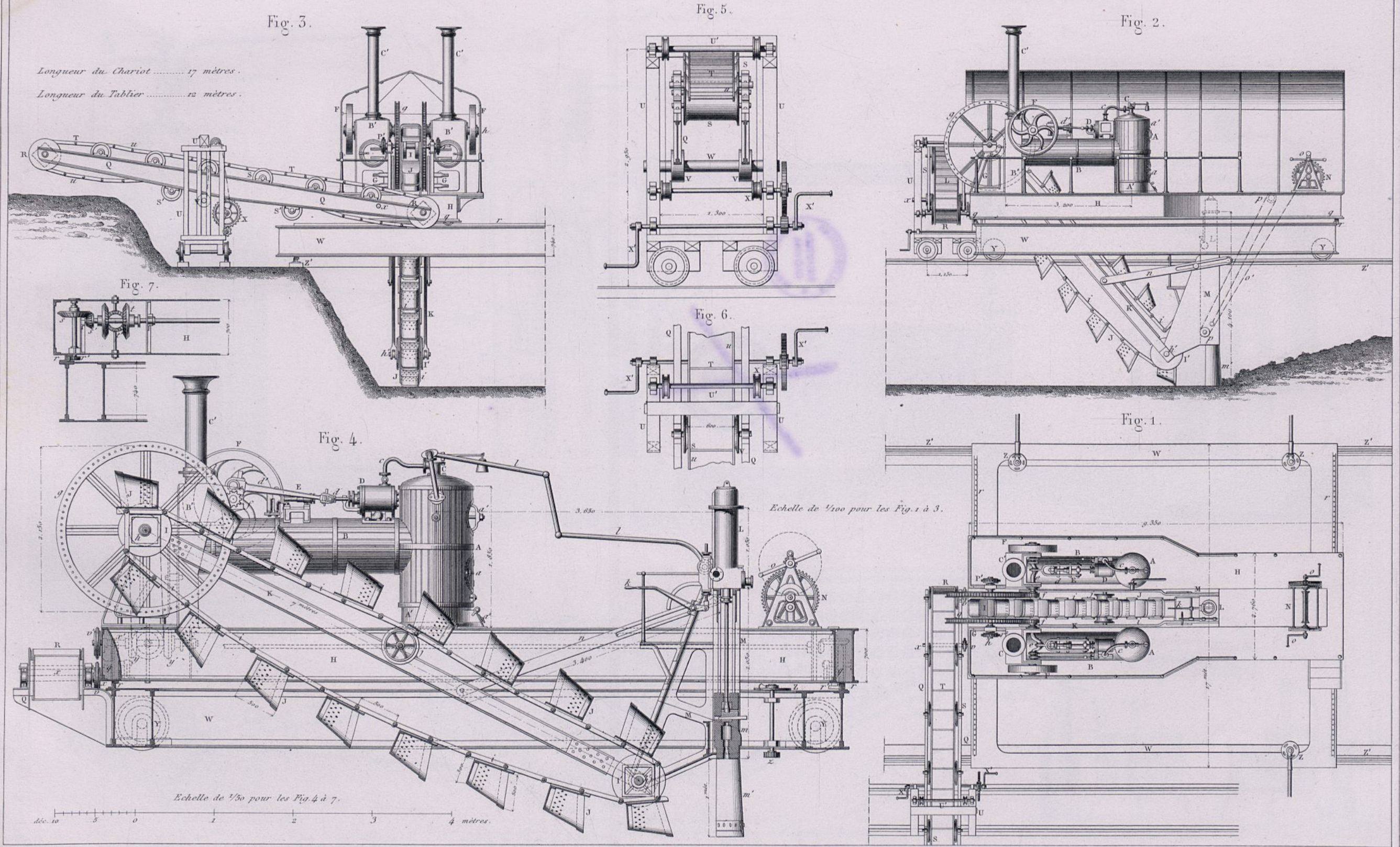


Echelle de 1/20 pour les Fig. 1. et 5.

Echelle de 1/10 pour les Fig. 2 à 4 et 6 à 10.









Appareil industriel continu.

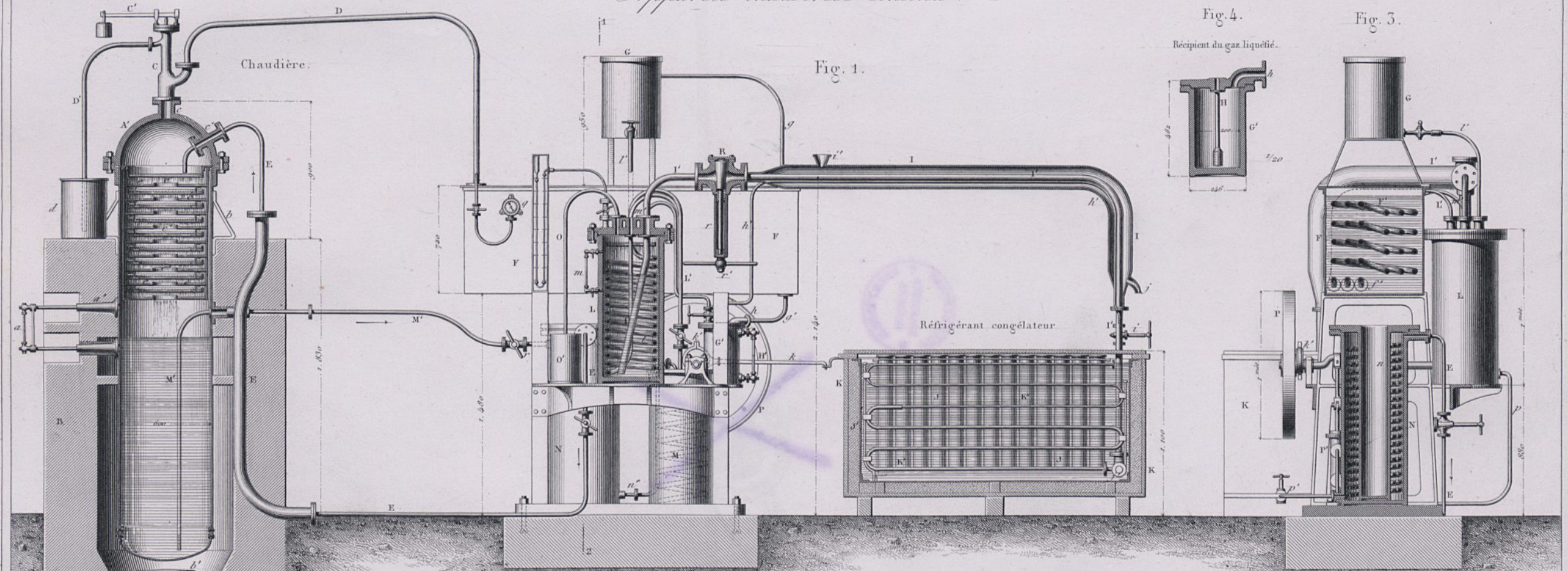
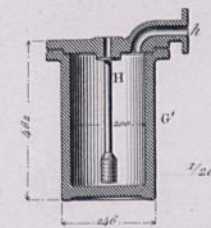


Fig. 4.

Fig. 5.

Récepteur du gaz liquéfié.



Appareil domestique intermittent.

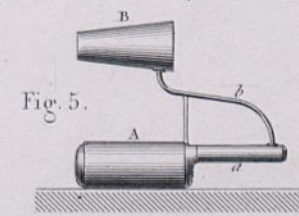


Fig. 5.

Fig. 7.

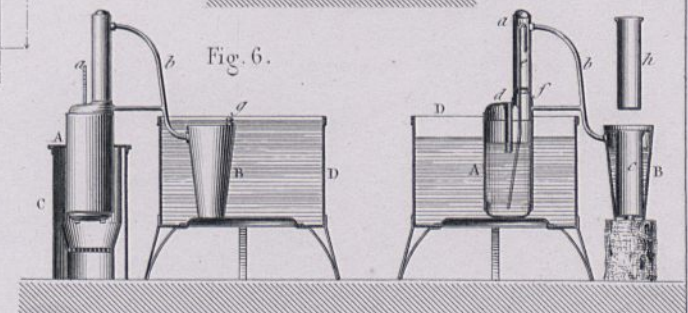
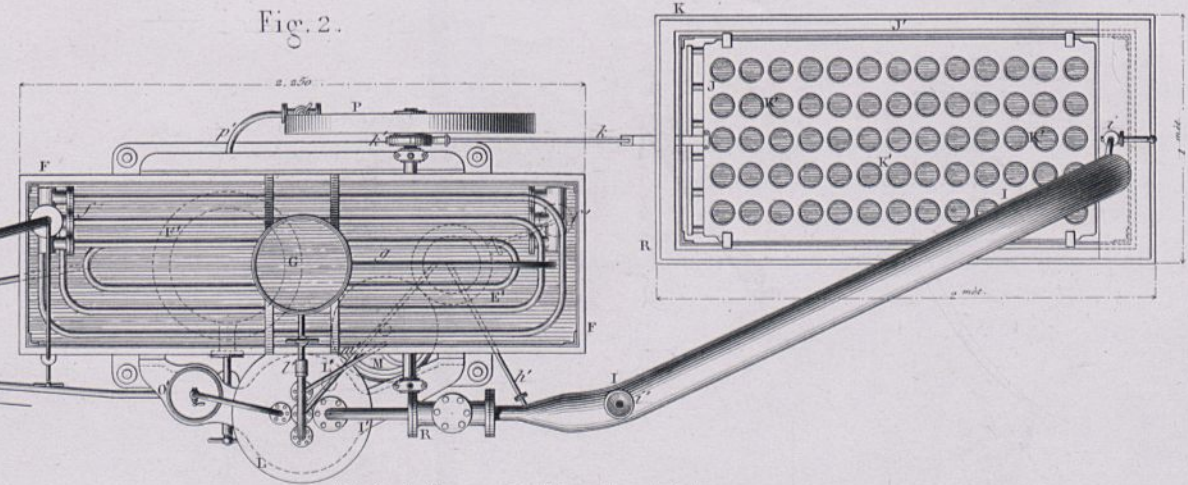
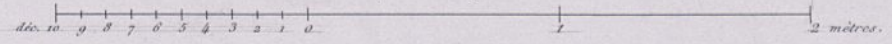


Fig. 6.

Fig. 2.

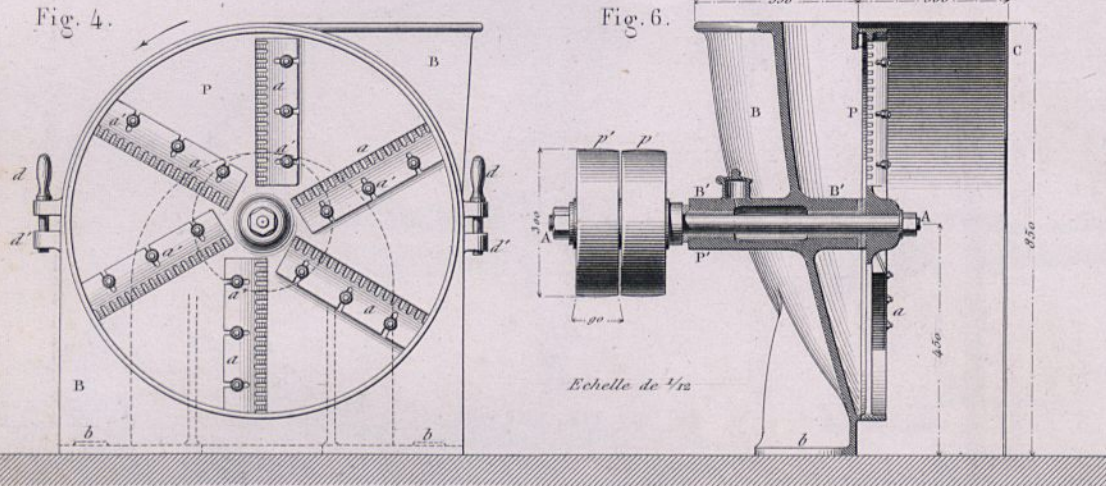


Echelle de 1/30 pour les Fig. 1 à 3 et 5 à 8.





Systeme Albaret et C^{ie}. à plateau vertical mobile.



Systeme Champonnois, à tambour fixe.

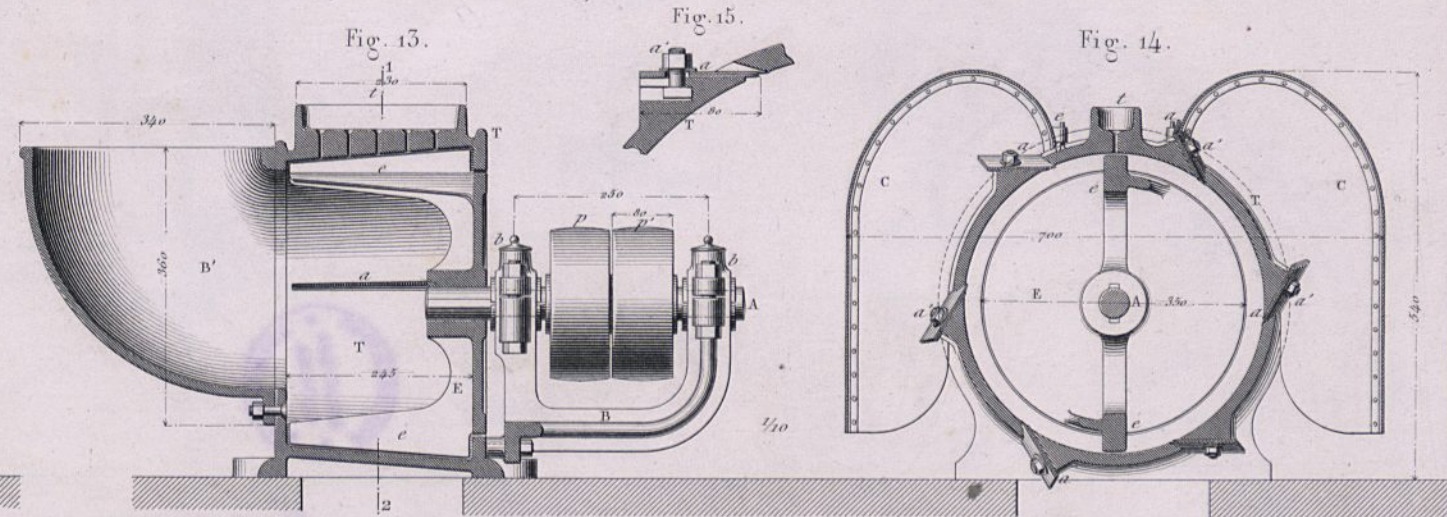
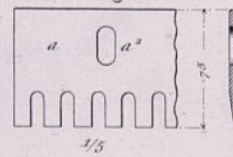


Fig. 5.



Systeme à tambour conique — Albaret et Comp^{ie} — Systeme à plateau horizontal fixe.

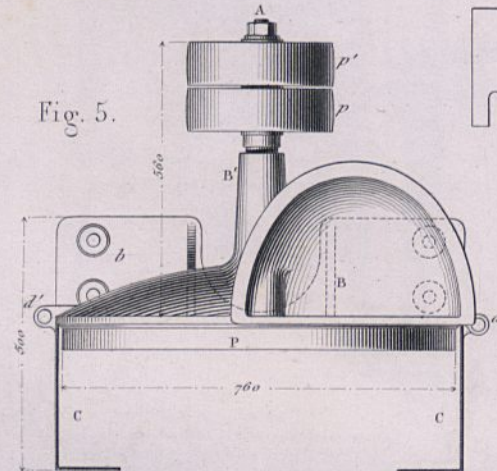


Fig. 7.

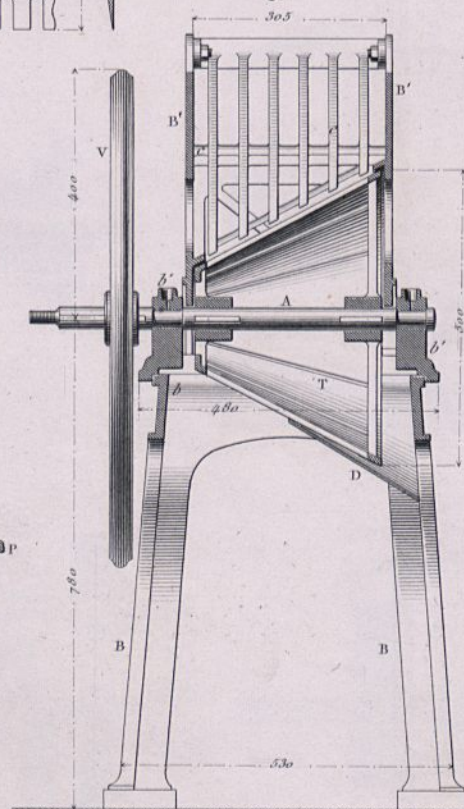


Fig. 8.

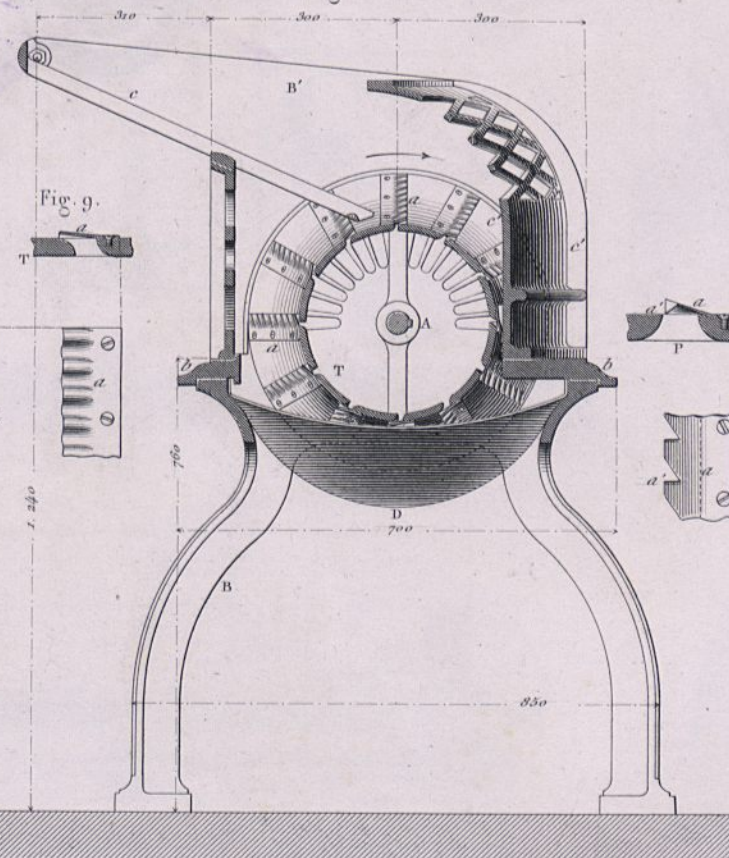


Fig. 9.

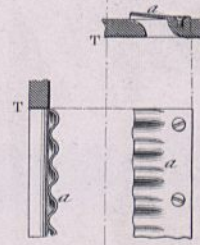
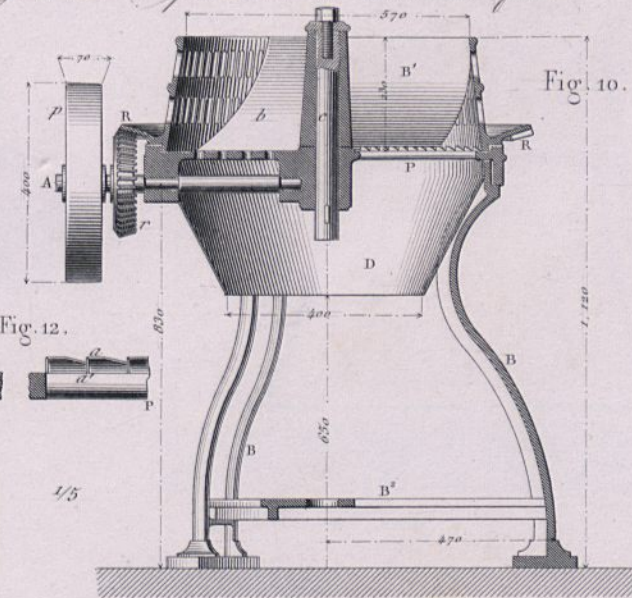


Fig. 10.



Modelle à disque vertical.

Fig. 1.

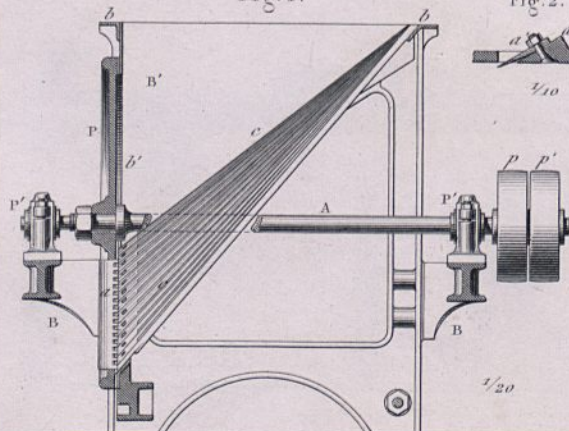
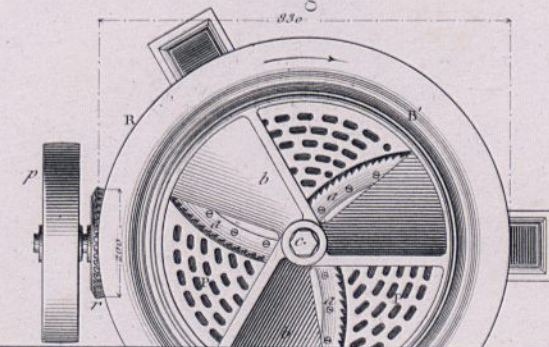


Fig. 2.

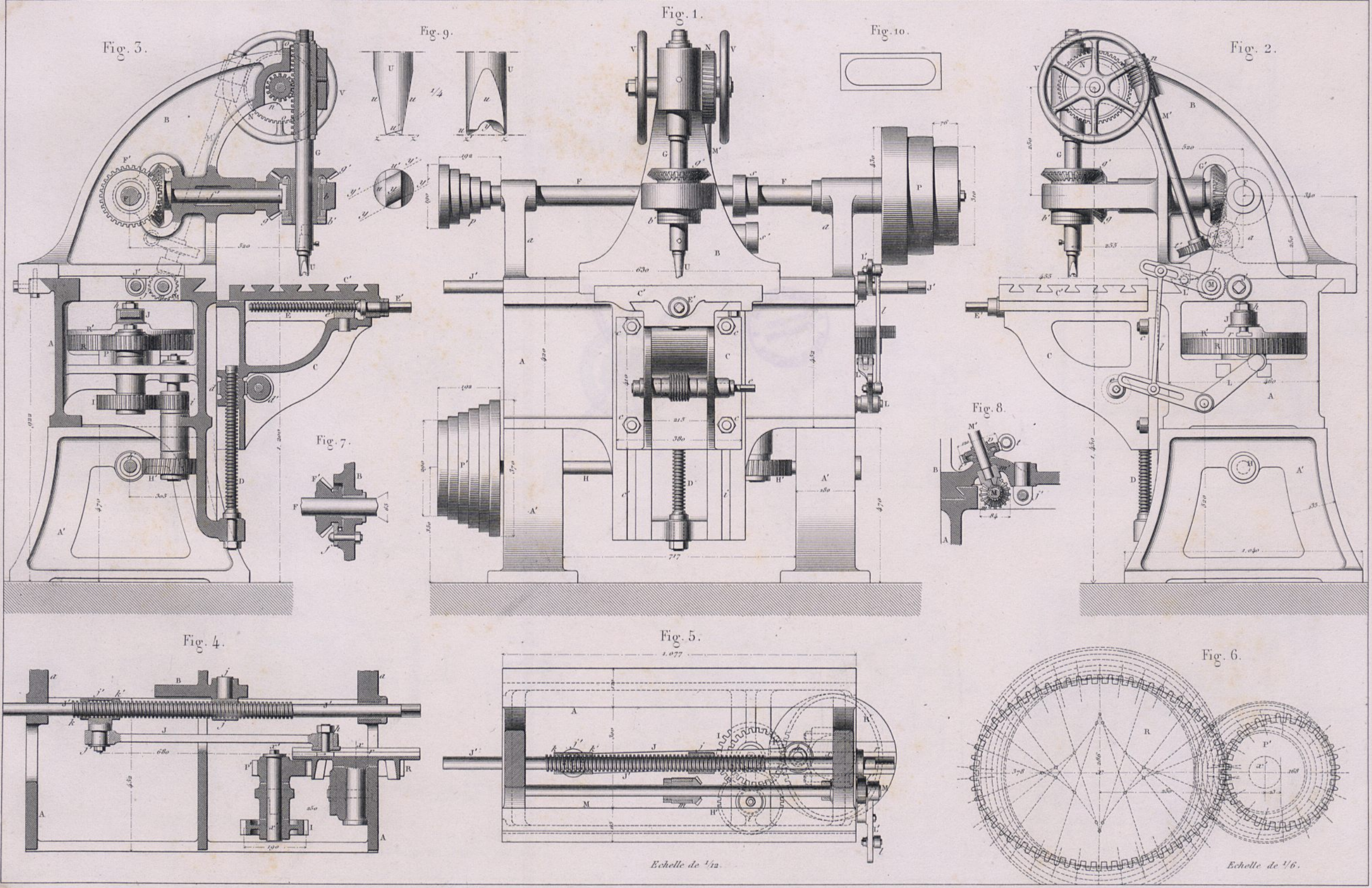


Fig. 11.



Echelle de 1/15 pour les Fig. 7. 8. 10. 11.





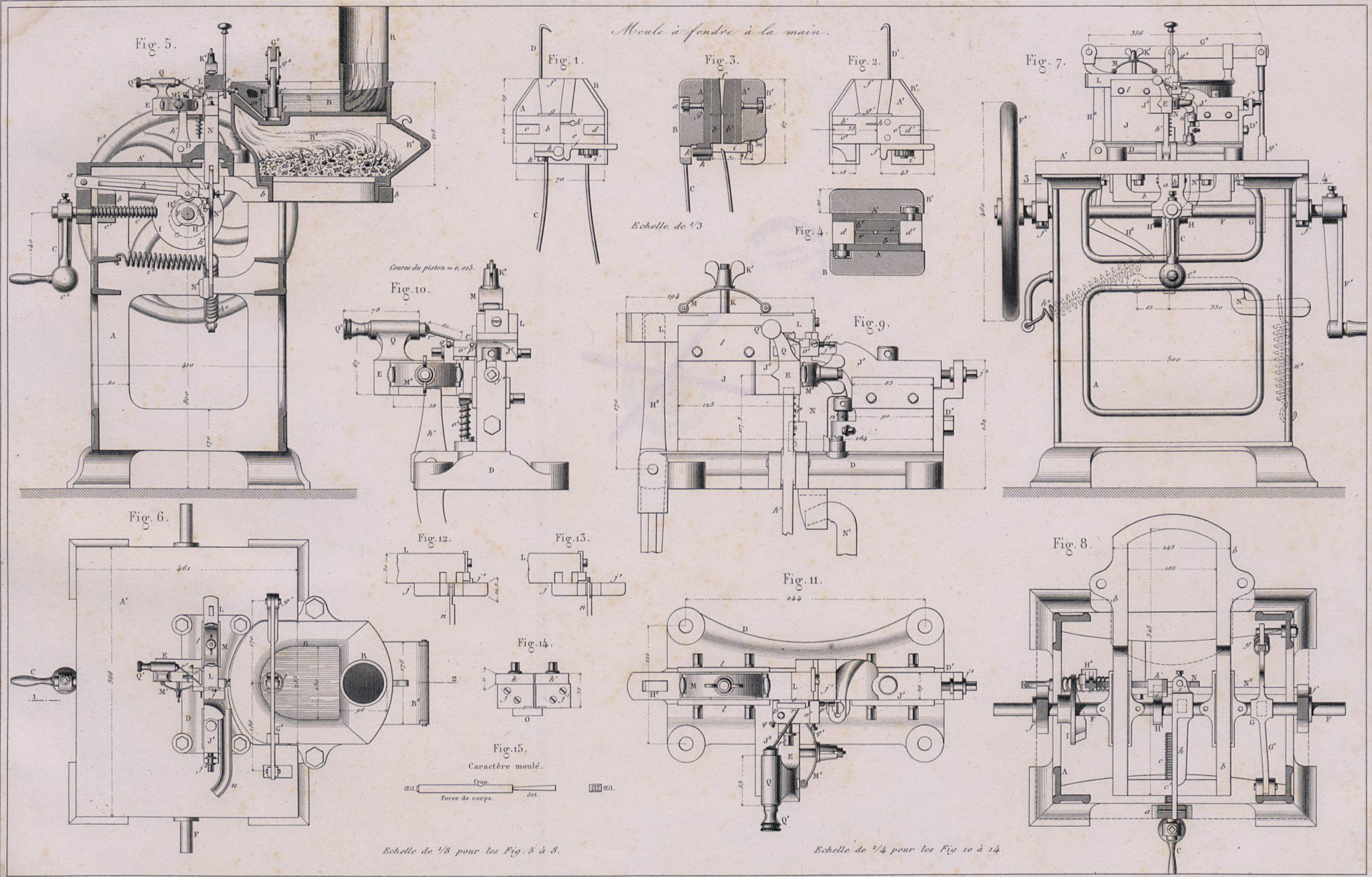


Moule à fondre à la main.

Echelle de 1/3

Echelle de 1/4 pour les Fig. 10 à 14.

Echelle de 1/8 pour les Fig. 5 à 8.





 BIBLIOTEKA GŁÓWNA
R-96 m
ARCHIWUM