

R 96

m

Archiwum



PUBLICATION INDUSTRIELLE
DES
MACHINES, OUTILS ET APPAREILS

LES PLUS PERFECTIONNÉS ET LES PLUS RÉCENTS

EMPLOYÉS

DANS LES DIFFÉRENTES BRANCHES DE L'INDUSTRIE FRANÇAISE ET ÉTRANGÈRE

PAR

ARMENGAUD AINÉ

INGÉNIEUR, ANCIEN PROFESSEUR AU CONSERVATOIRE IMPÉRIAL DES ARTS ET MÉTIERS

MEMBRE HONORAIRE DE LA SOCIÉTÉ PHILOMATIQUE DE BORDEAUX, MEMBRE DE LA SOCIÉTÉ D'ENCOURAGEMENT, DES INGÉNIEURS CIVILS ET DE LA SOCIÉTÉ INDUSTRIELLE DE MULHOUSE

TOME DOUZIÈME



PLANCHES

1912.499,
PARIS

CHEZ L'AUTEUR, 45 RUE SAINT-SÉBASTIEN

BOULEVARD DES FILLES-DU-CALVAIRE

ET CHEZ LES PRINCIPAUX LIBRAIRES DE LA FRANCE ET DE L'ÉTRANGER

—
1860

FABRICATION INDUSTRIELLE

MACHINES, OUTILS ET APPAREILS

DES PLUS RECENTES ET DES PLUS REPUTÉES

DANS LES DIVERSES BRANCHES DE L'INDUSTRIE FRANÇAISE ET ÉTRANGÈRE

ARMÉE



Sp. 2/924.



PARIS

CHEN LAFONT, 33 RUE SAINT-ANDRÉ

TABLE DES PLANCHES

DU TOME DOUZIEME DE LA PUBLICATION INDUSTRIELLE

PLANCHES.	1 ^{re} LIVRAISON.	PAGES.	PLANCHES.	6 ^e LIVRAISON.	PAGES.		
1	Machine soufflante, accouplée, à tiroir et à grande vitesse, par la C ^e des établissements Cavé. — Soufflerie de MM. THOMAS et LAURENS....	3	21	Machine à raboter verticale, par MM. MAZELINE frères et CODY.....	250		
2			22	Fours et appareils propres au raffinage du soufre.....	255		
3			23	Fabrication de la poudre. — Moulin à meules de la poudrerie du Pérou.	266		
4			24	Manufacture des tabacs de Strasbourg. — Disposition générale de la salle de râpage.....	287		
	Machine propre au dégraissage des laines, par M. LEGROS. — Machine à laver par M. RICKLI.....	20					
	Machine à fabriquer les pignons de crics, de l'usine de GRAFFENSTADEN.	35					
	2 ^e LIVRAISON.			7 ^e LIVRAISON.			
5	Indicateur électrique de la marche des trains, par M. REGNAULT....	44	25	Manufacture des tabacs de Strasbourg. (Suite.) — Moulins à noix à transmission perfectionnée, par M. E. ROLLAND. — Élévateur et tamis.	287		
6	Cisailles pour les grosses tôles, par MM. THOMAS et LAURENS.....	65	26				
7	Pont tournant pour la traversée de la Somme, à Abbeville (chemin de fer du Nord), exécuté sous la direction de M. COUCHE.....	72	27			Machines marines de 160 chevaux, construite par M. NILLUS.....	311
8			28			Construction des machines. — Pistons des moteurs à vapeur.....	331
	3 ^e LIVRAISON.			8 ^e LIVRAISON.			
9	Pont tournant. (Suite.) — Pont fixe sur le canal de Saint-Denis...	89	29	Construction des machines. (Suite.) — Pistons des moteurs à vapeur.	331		
10	Manufacture des tabacs de Strasbourg. — Tire-sac double et grue roulante, par M. E. ROLLAND.....	92	30	Appareils à fabriquer les tuyaux en plomb, étamés à l'intérieur et à l'extérieur, par M. SÉBILLE.....	360		
11	Fours à carboniser les bois propres à la fabrication du charbon de poudre.	100	31	Turbines hydrauliques et pompes à élever l'eau, construites par MM. FONTAINE et BRAULT.....	367		
12	Machine à vapeur à action directe pour l'élévation des eaux, construite par la C ^e des établissements Cavé.....	118	32	Télégraphe électrique. — Appareil morse écrivant, par M. BRÉGUET..	382		
	4 ^e LIVRAISON.			9 ^e LIVRAISON.			
13	Élévation et distribution des eaux. — Divers systèmes de pompes....	153	33	Télégraphe électrique. — Appareils à lettres et à cadrans, par M. BRÉGUET.	396		
14	Machines à travailler les bois, de l'usine de GRAFFENSTADEN.....	176	34	Métier à filer à l'eau chaude de M. KAY, construit par M. FAIRBAIRN...	425		
15	Filature du lin et du chanvre. — Étaleuse et premier étirage, par MM. WINDSOR frères.....	184	35	Machines à vapeur et pompes horizontales pour l'élévation des eaux, construites pour la C ^e générale des eaux, par M. FARCOT.....	440		
16							
	5 ^e LIVRAISON.			10 ^e LIVRAISON.			
17	Fabrication du papier. — Appareils de lessivage.....	198	37	Pompes et machines motrices pour l'élévation des eaux. (Suite).....	440		
18	Fonderie de fer. — Four parabolique, par M. CORBIN-DESBOISSIÈRES.	214	38	Tour parallèle de grande dimension, construit par M. CALLA.....	471		
19	Pompes doubles, à piston sans frottement, par M. J. NILLUS jeune....	234	39	Grues sans tambour et à chaîne de Galle, par M. C. NEUSTADT.....	489		
20	Bocard et Patouillets destinés au lavage des minerais de fer.....	239	40	Machine à fabriquer les chaînes à maillons doubles, par M. WEISENBORN.	510		

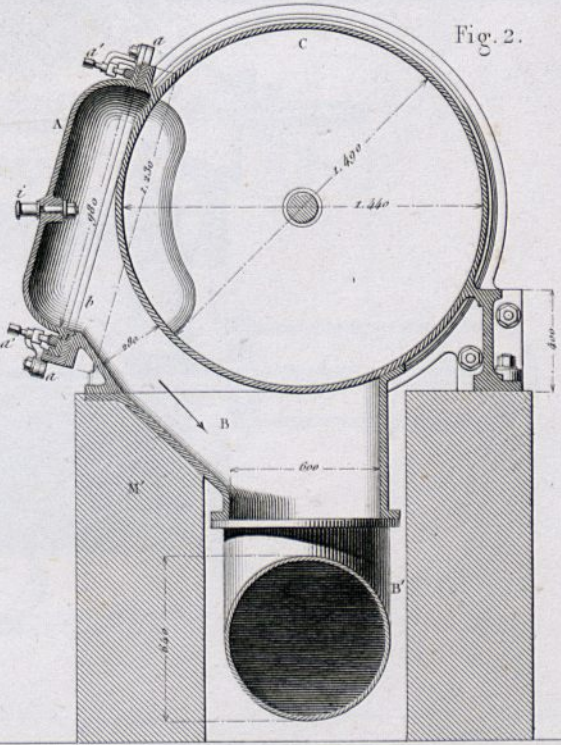
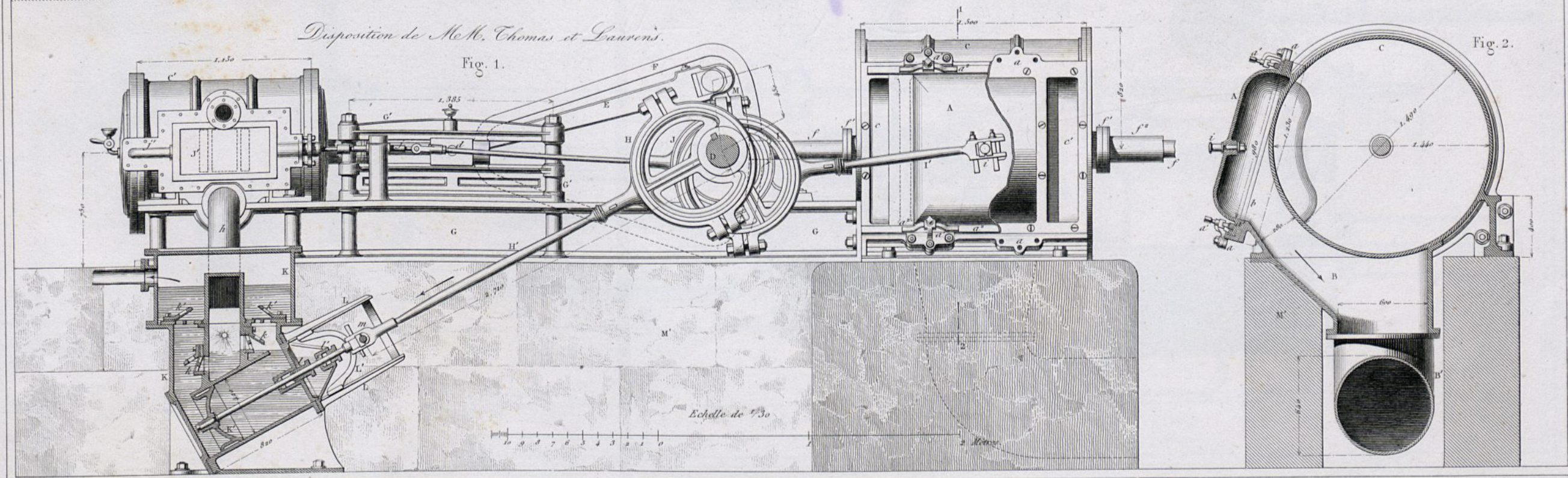
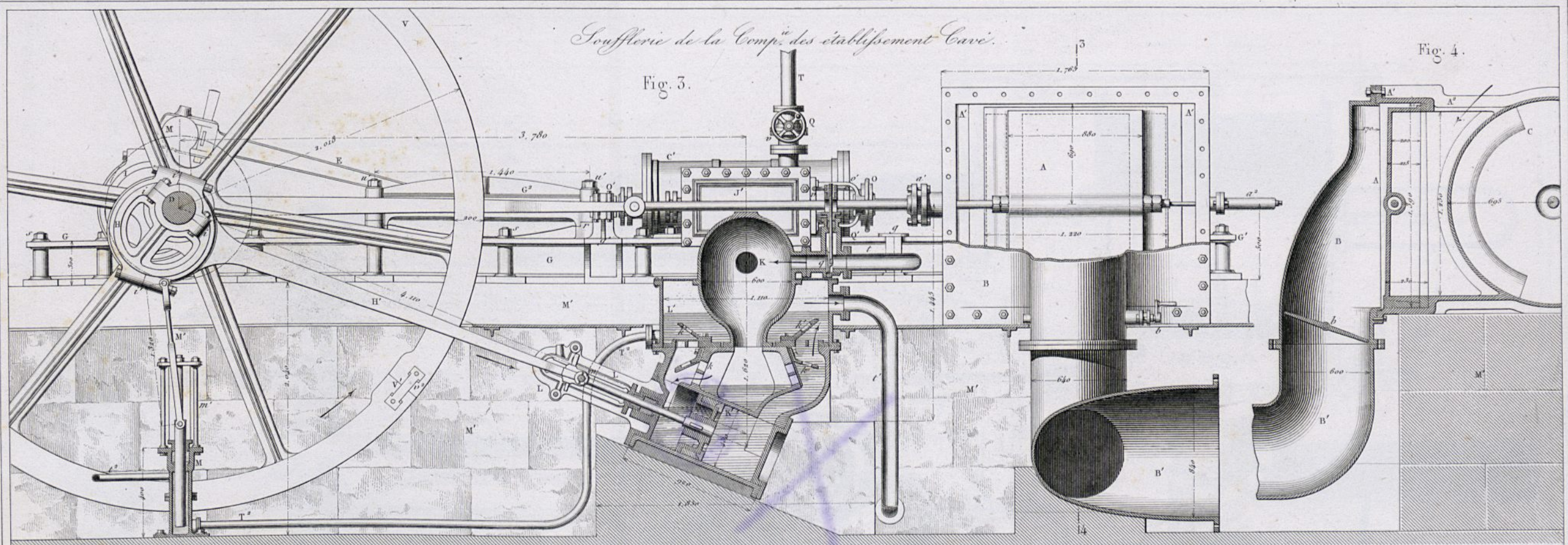
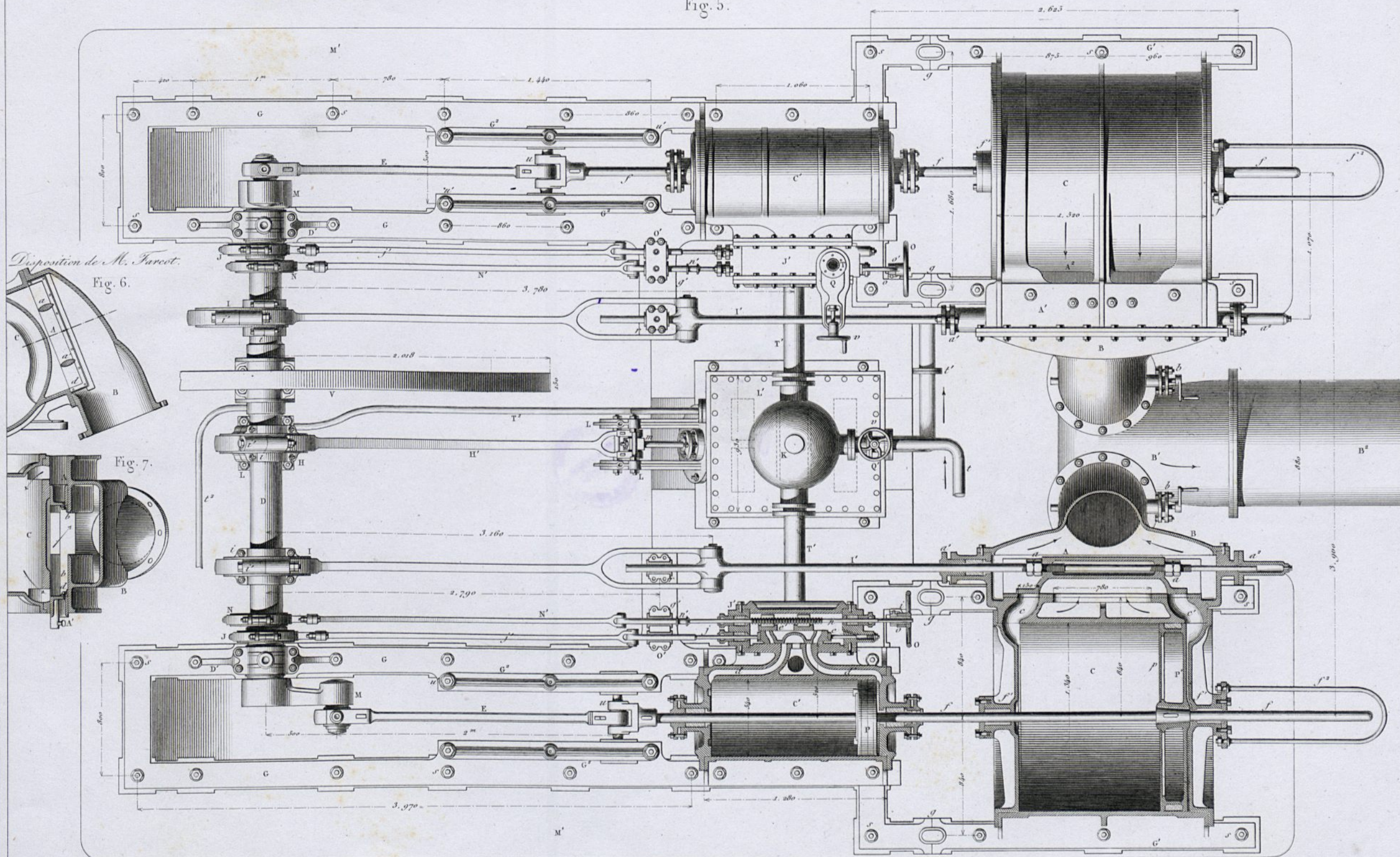



Fig. 5.



Disposition de M. Farcot.

Fig. 6.

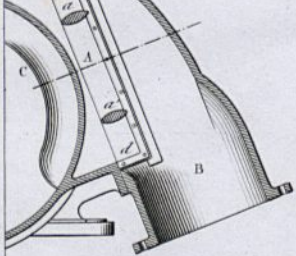
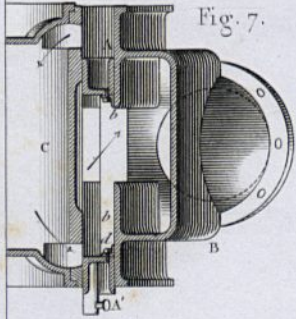
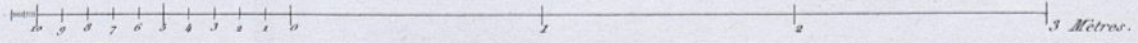

Fig. 7.



Echelle de 1/30.





Machine à dégraisser les laines.

Fig. 3.

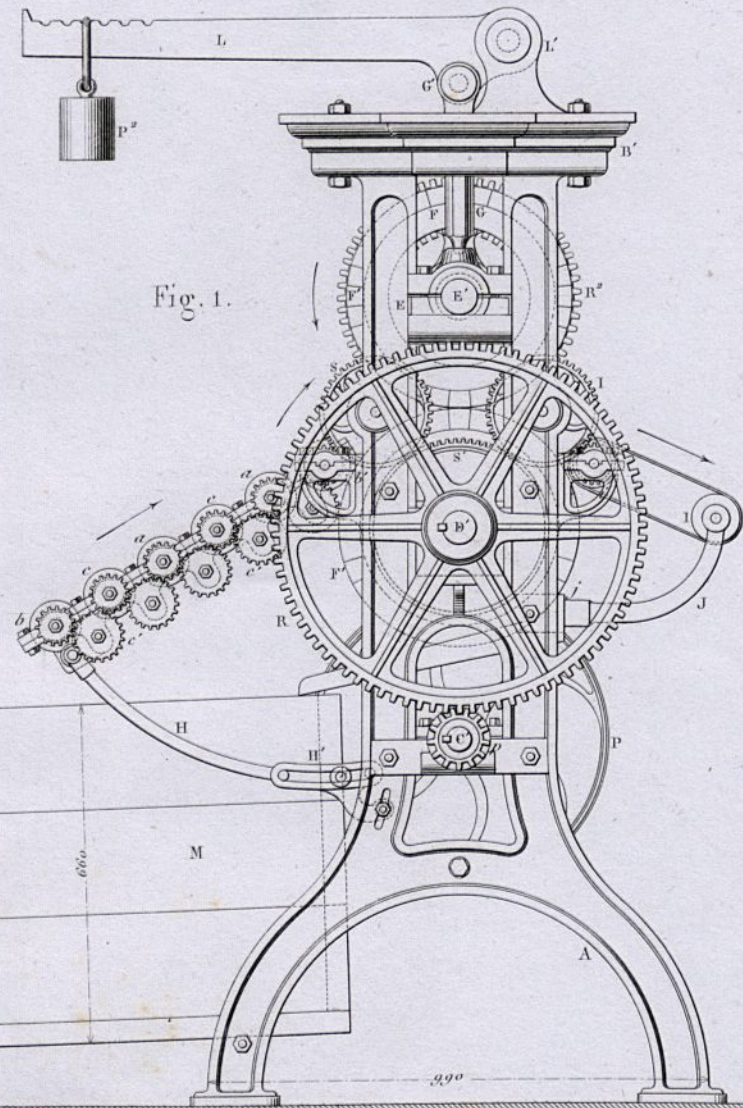

Fig. 1.

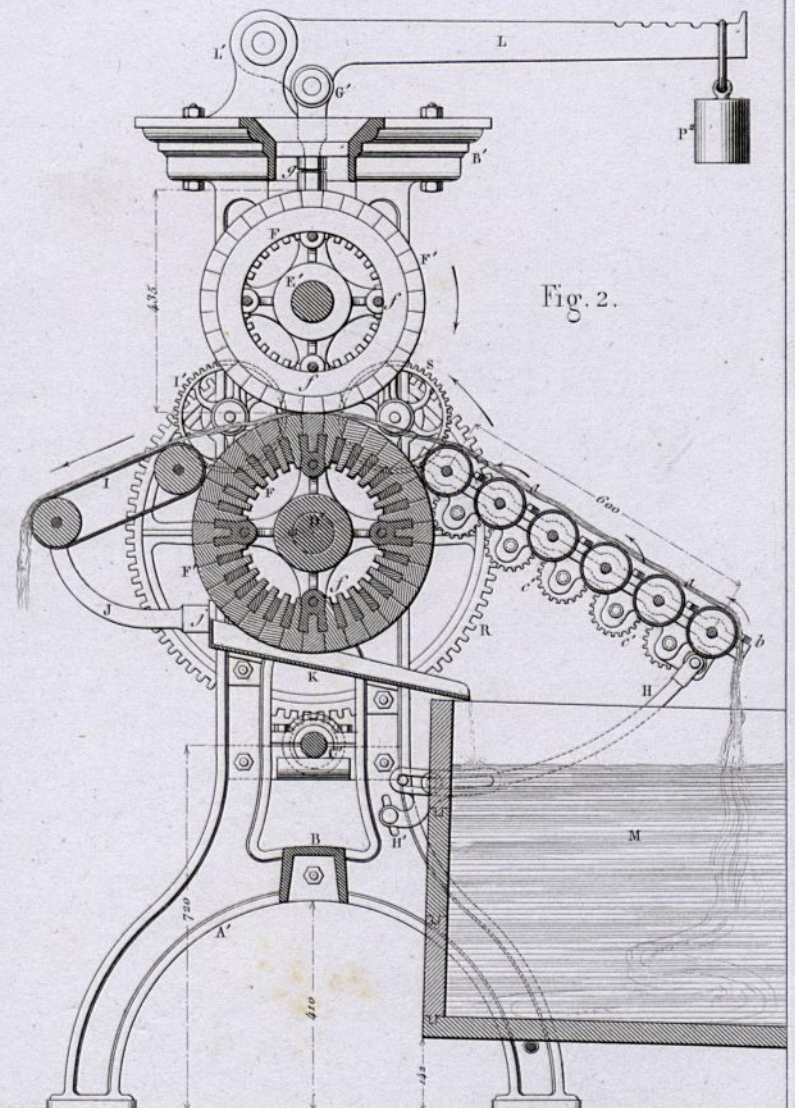
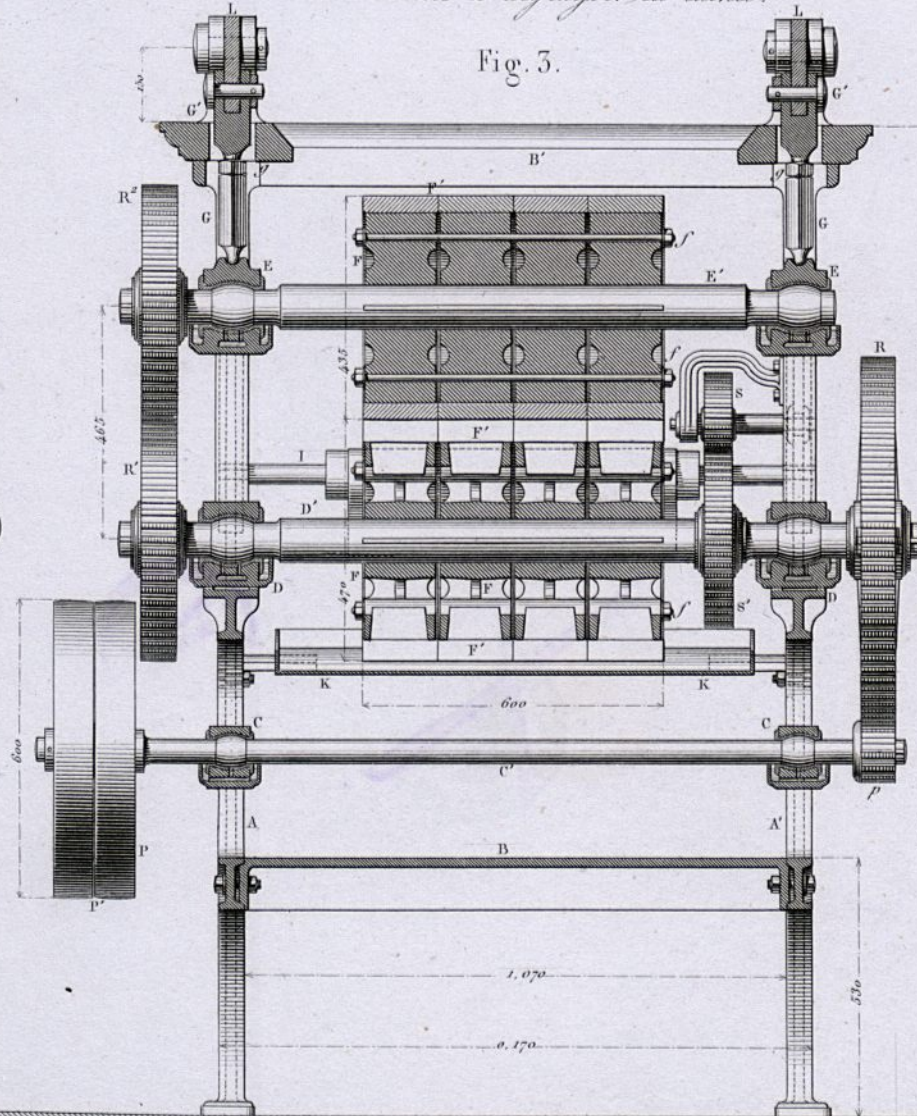
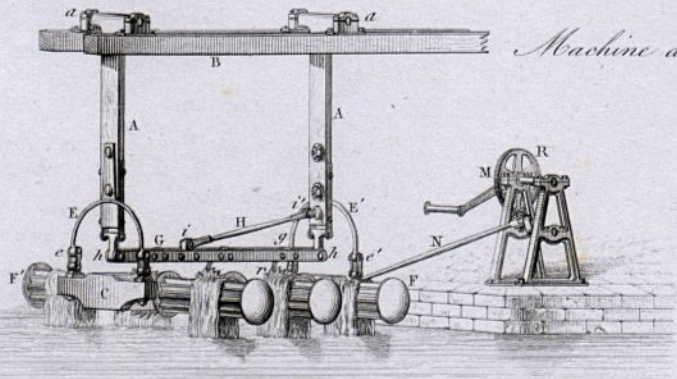

Fig. 2.

Fig. 4.



Machine à laver les matières textiles.

Fig. 6.

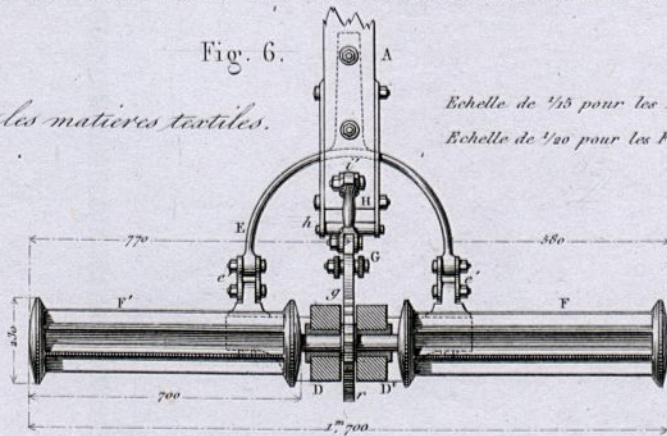

Echelle de 1/3 pour les Fig. 1 à 3.
Echelle de 1/50 pour les Fig. 5 et 6.

Fig. 5.

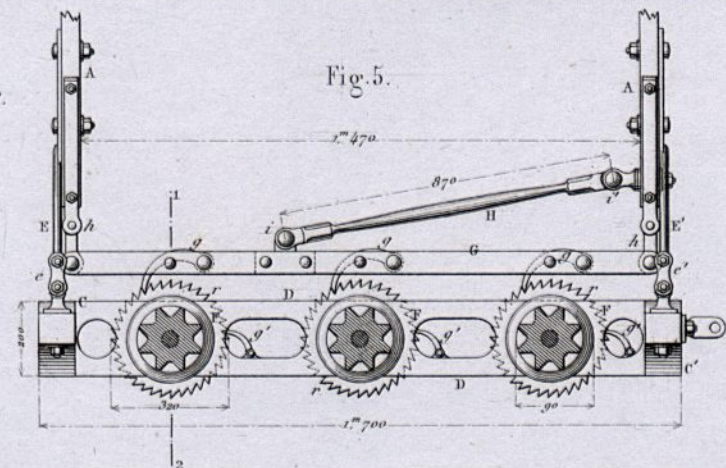



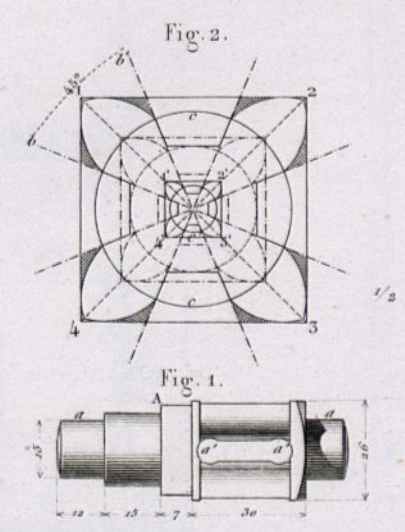
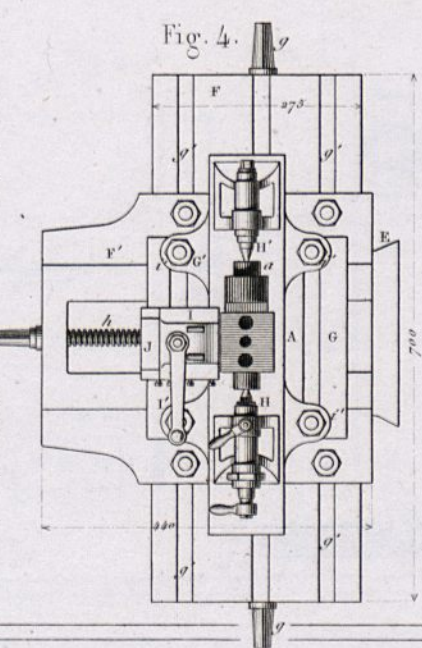
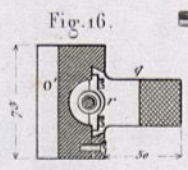
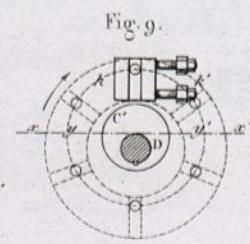
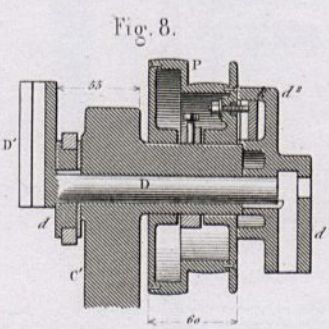
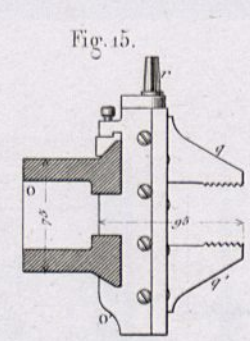
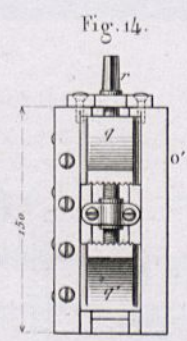
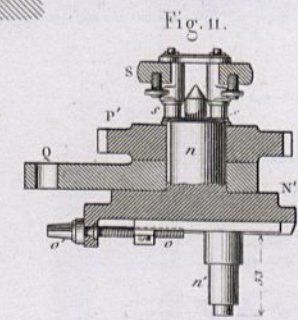
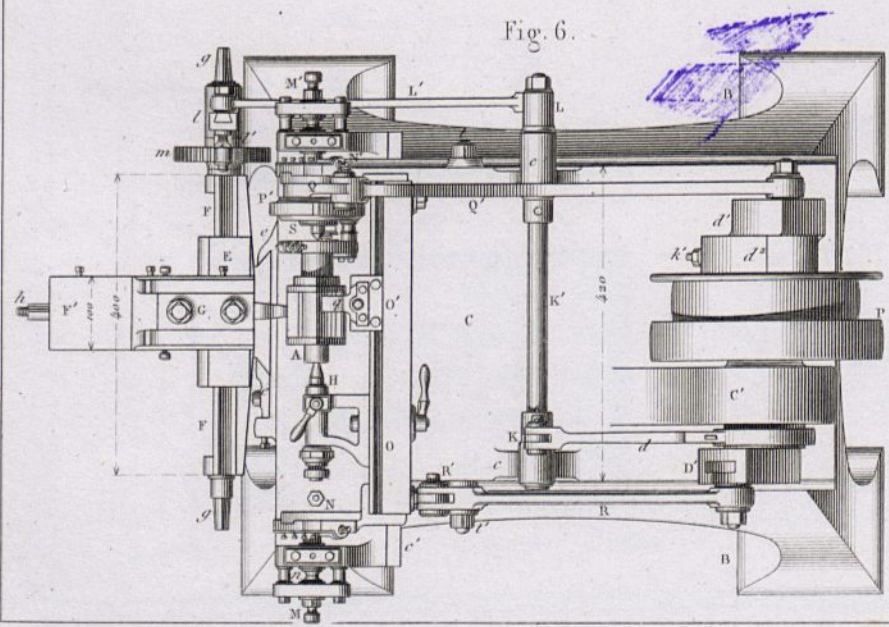
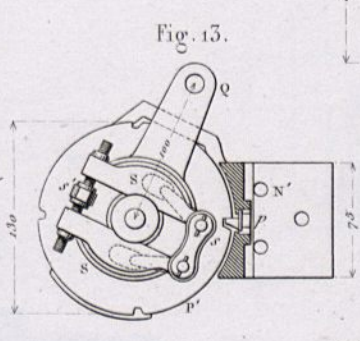
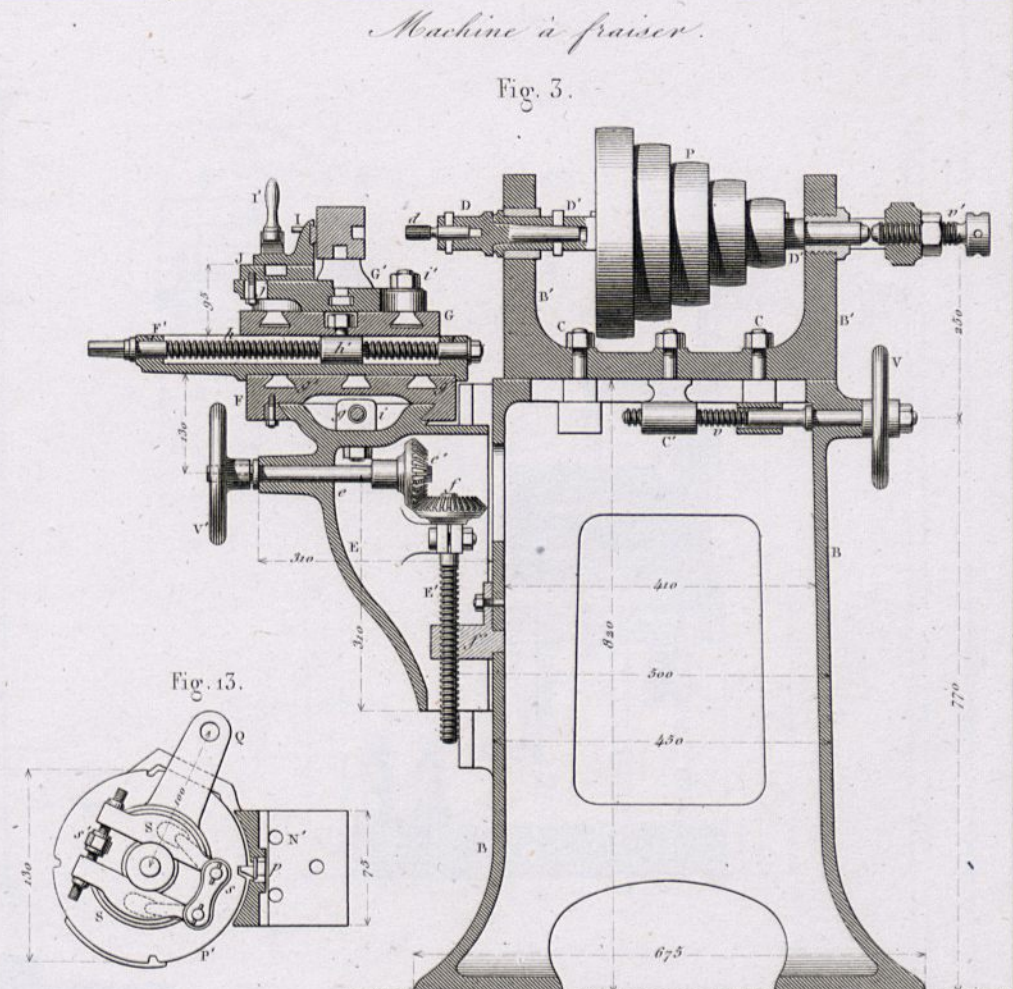
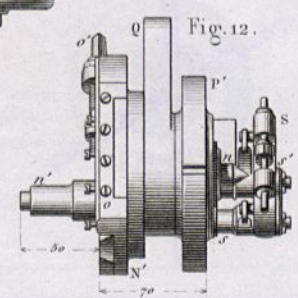
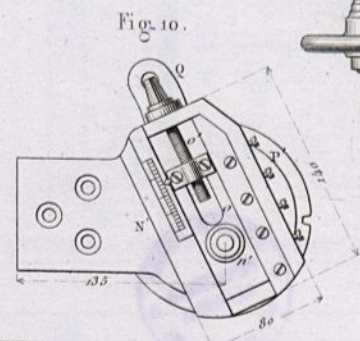
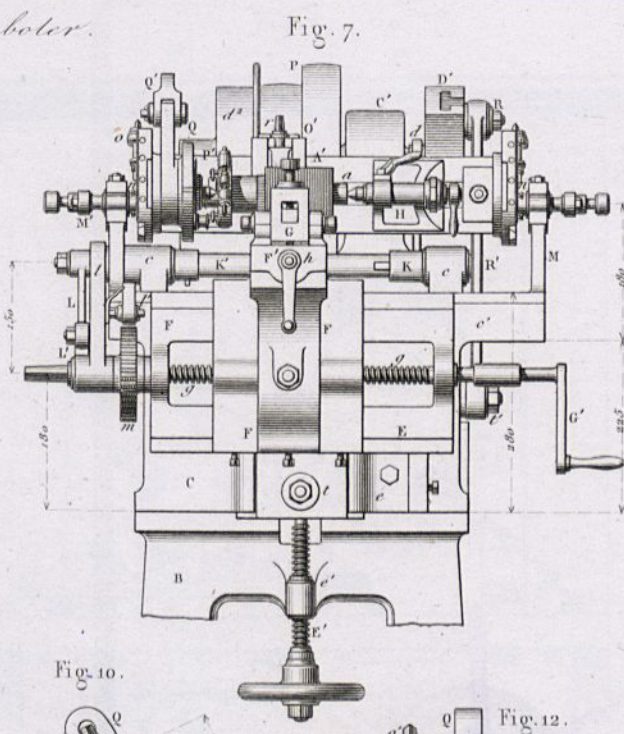
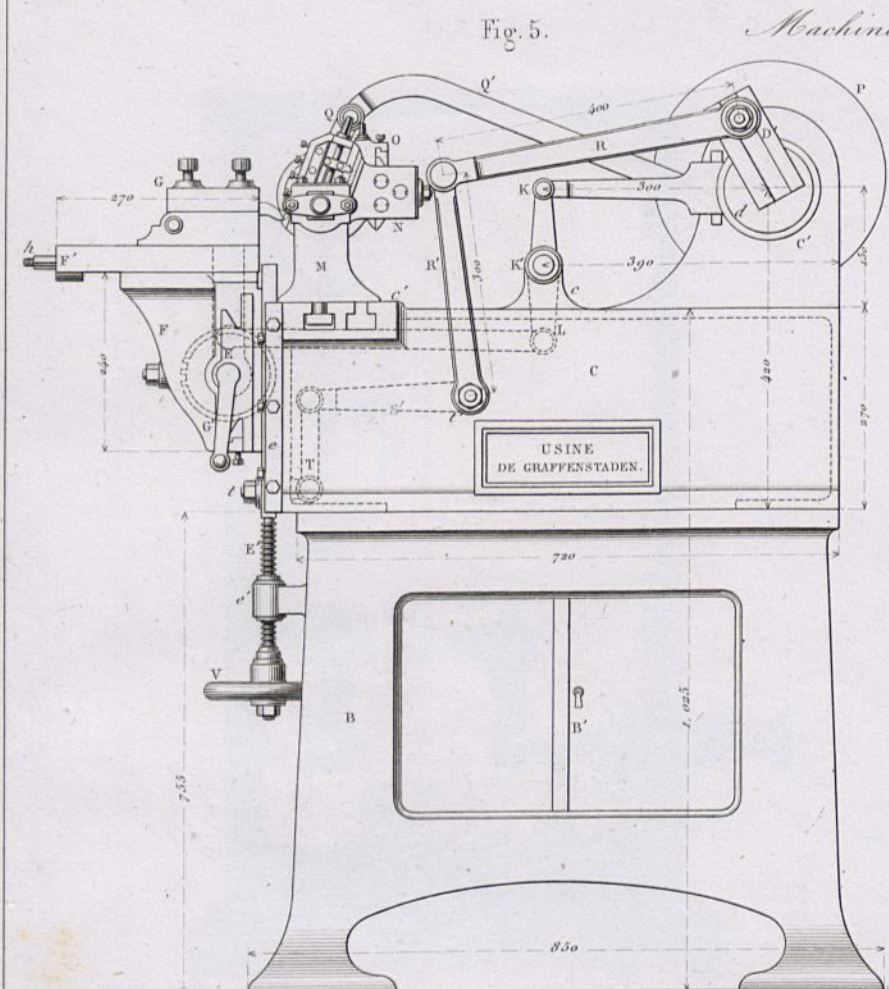

Echelle de 1/5 pour les Fig. 10 à 16.

Echelle de 1/10 pour les Fig. 3 à 9.



Fig. 2.

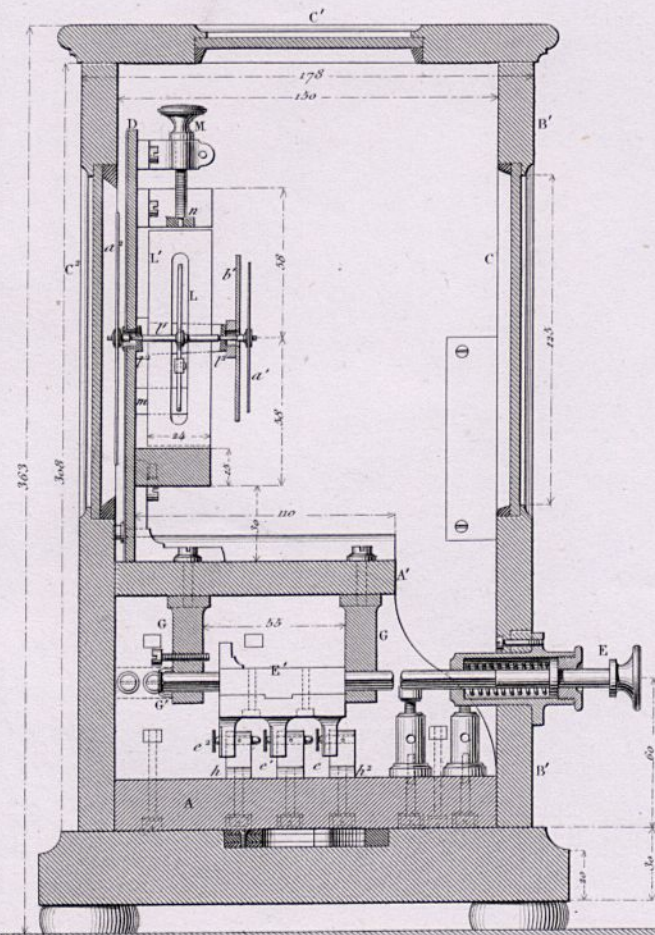

Fig. 1.

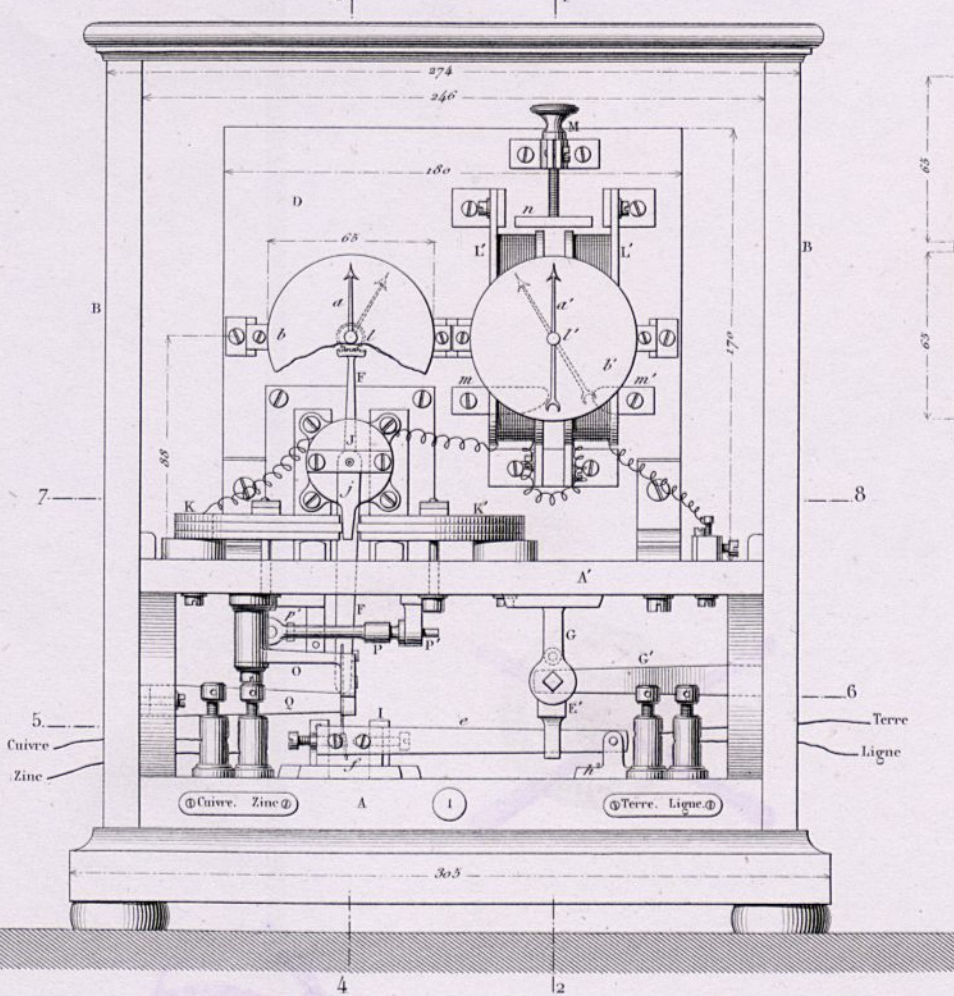

Fig. 6.

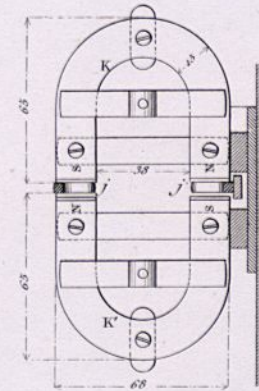
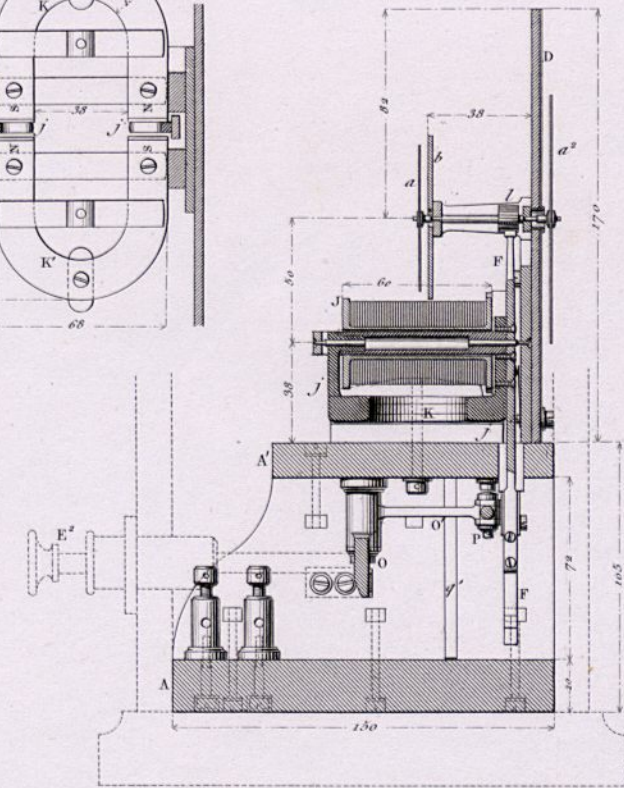

Fig. 5.



Paratonnerre.

Fig. 12.

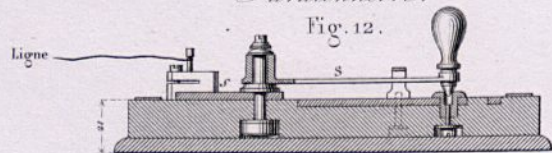

Fig. 7.



Fig. 4.

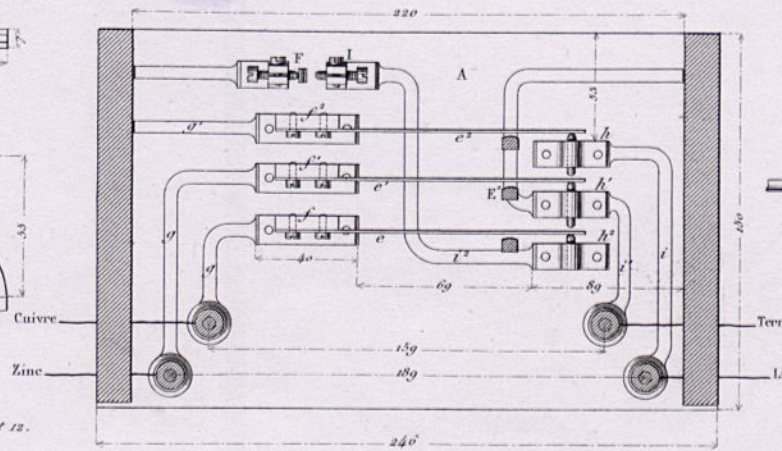

Fig. 9.

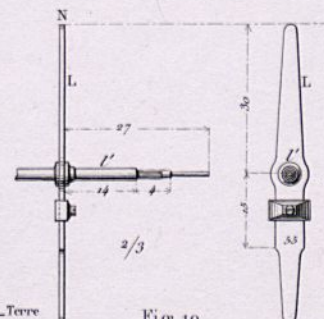

Fig. 5.

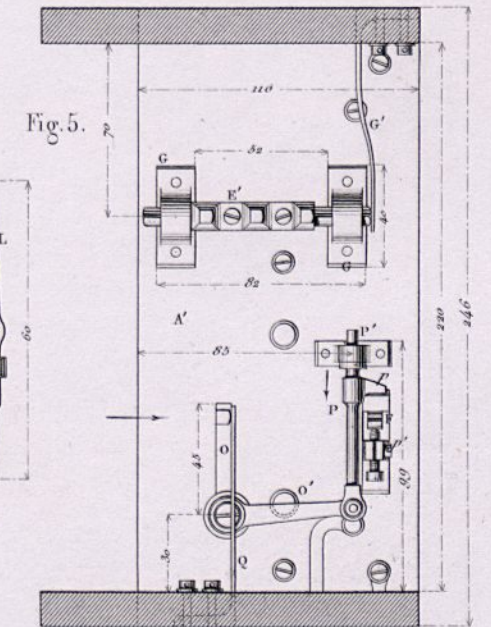

Fig. 11.

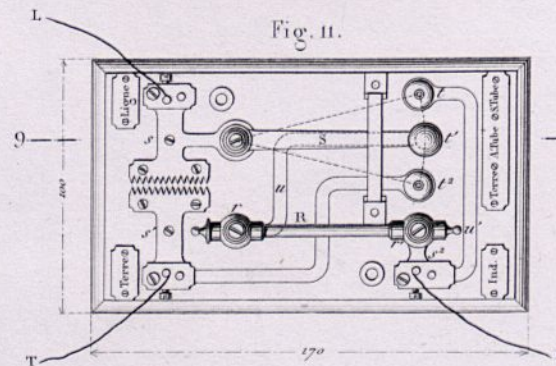
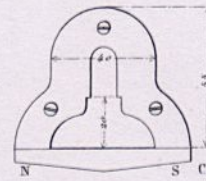

Fig. 8.



Echelle de 1/3 pour les Fig. 1 à 8, 11 et 12.



Disposition de M. M. Thomas et Laurens.

Cisaille construite par la Comp. des établissements Cavi.

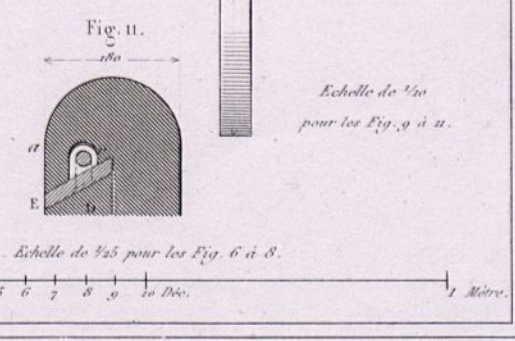
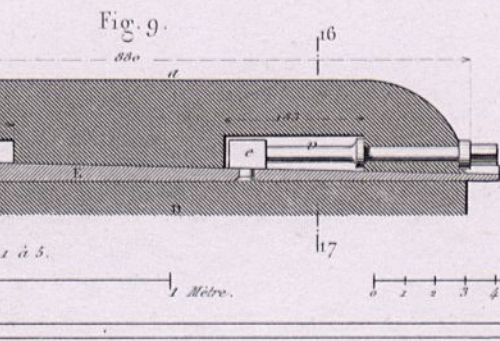
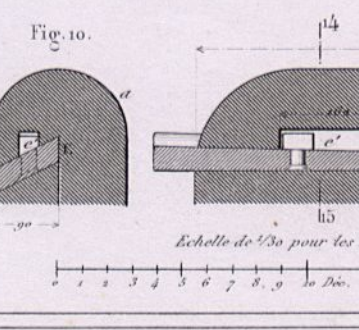
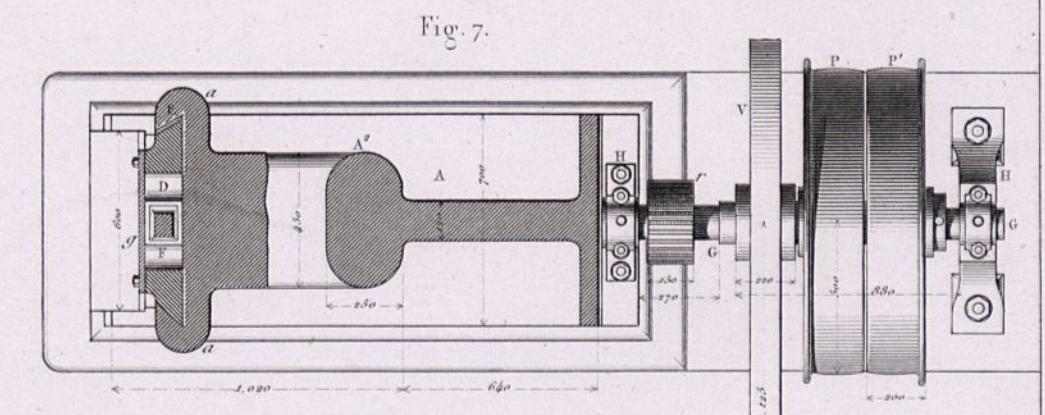
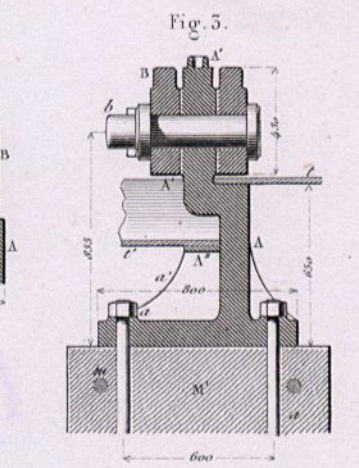
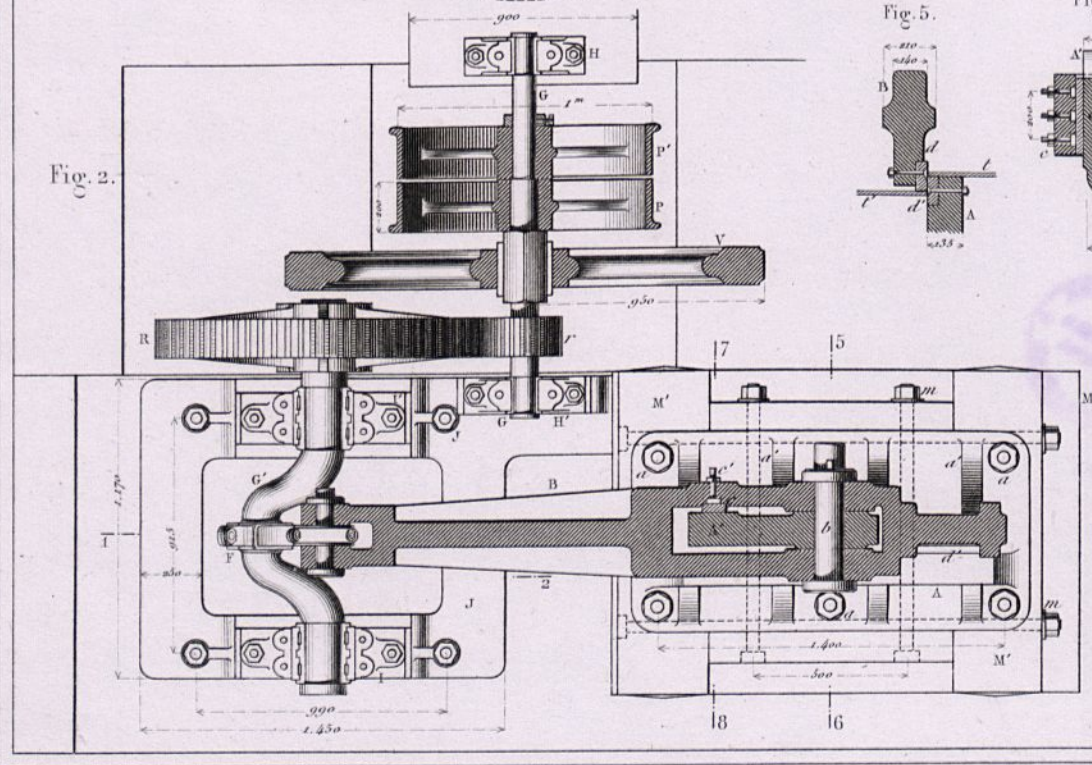
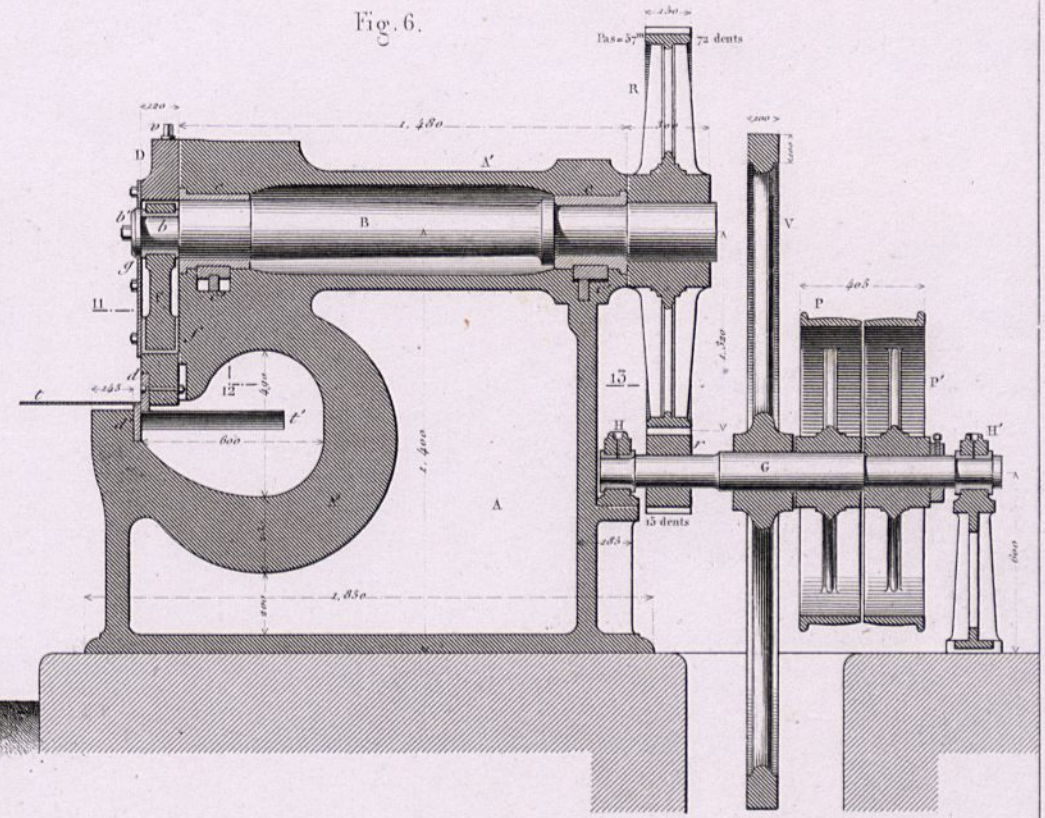
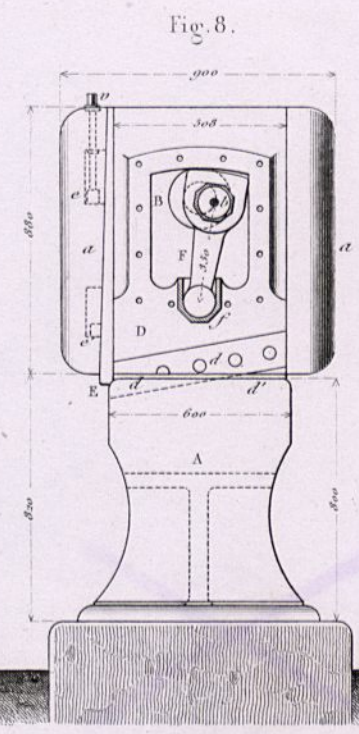
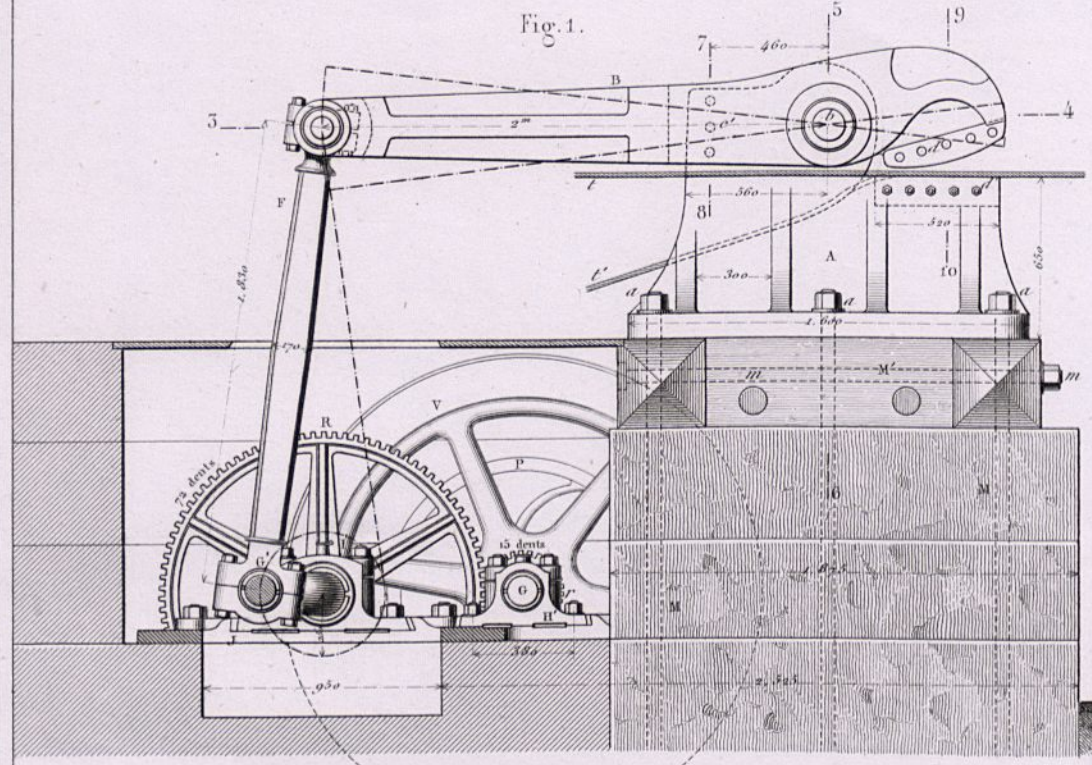

Echelle de 1/30 pour les Fig. 1 à 5.

Echelle de 1/25 pour les Fig. 6 à 8.

Echelle de 1/50 pour les Fig. 9 à 11.





Fig. 1.

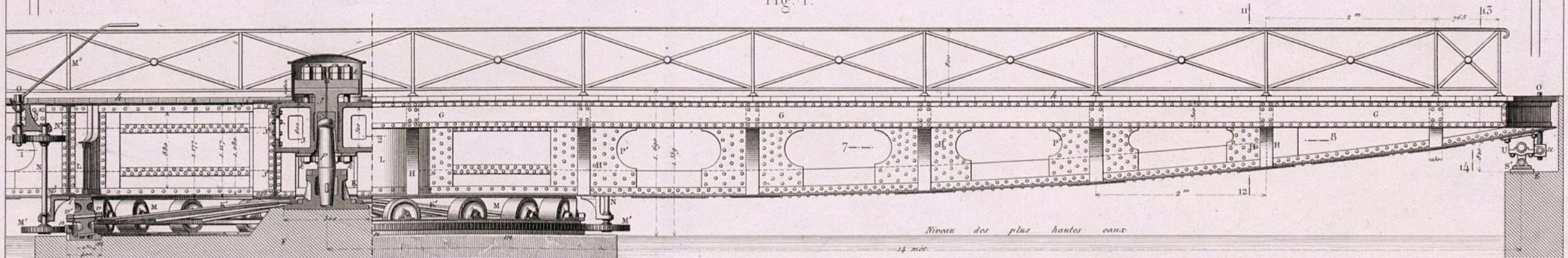

Fig. 4.

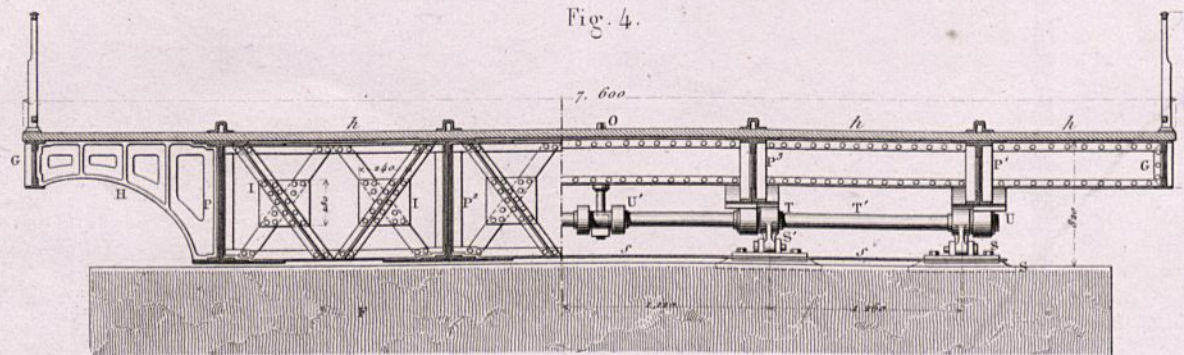
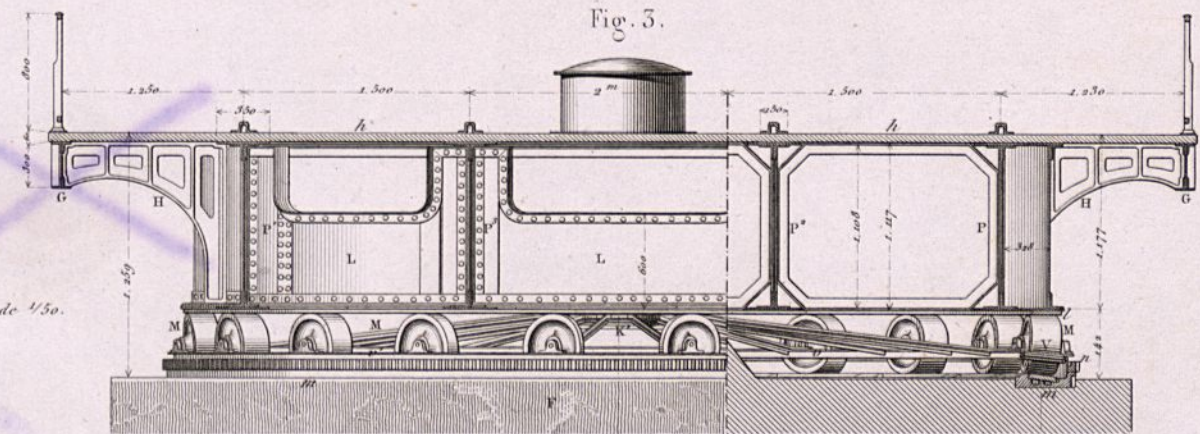

Fig. 3.



Echelle de 1/50.

Fig. 2.

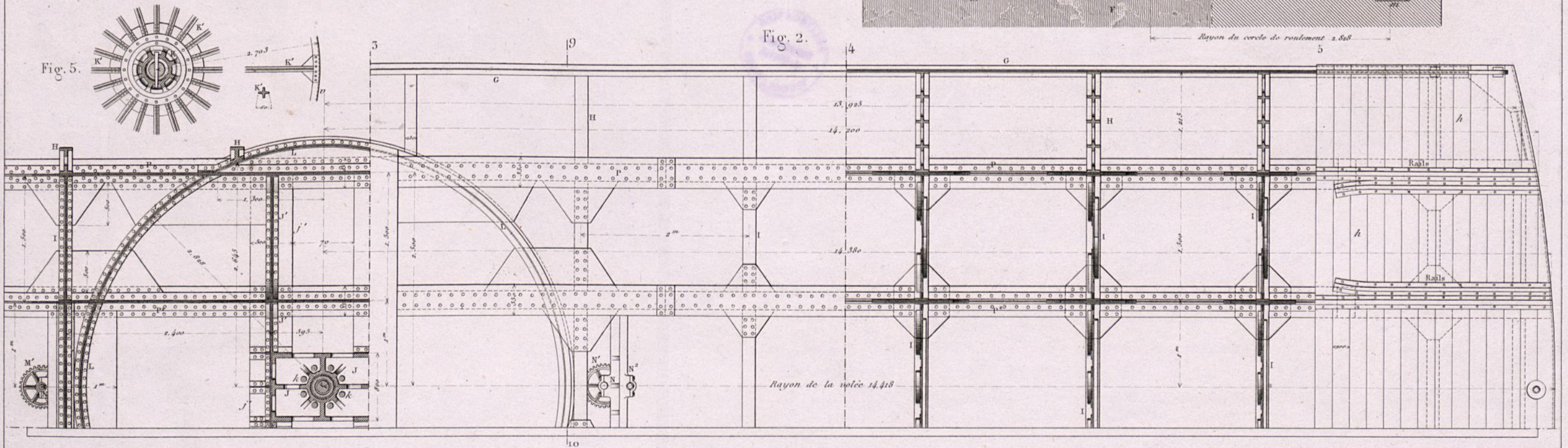

Fig. 5.

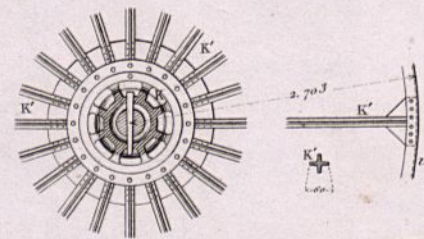



Fig. 6.

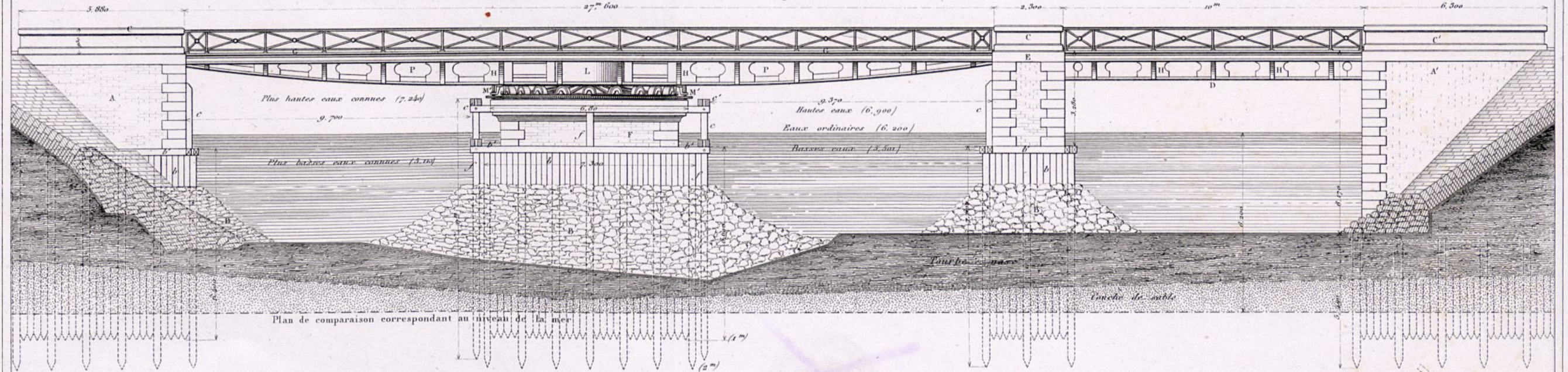

Fig. 8.

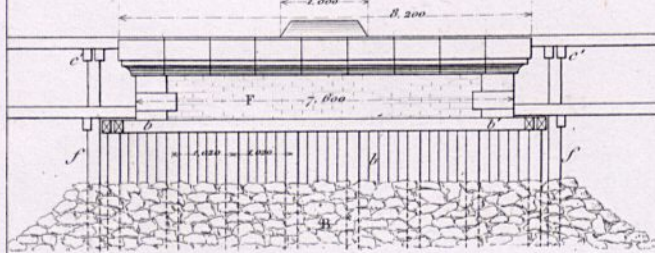

Fig. 11.

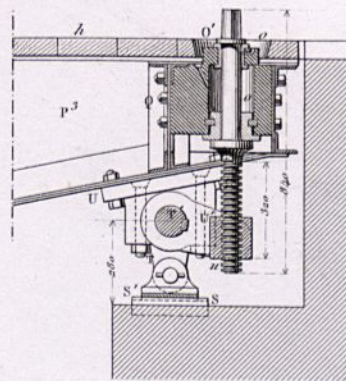

Fig. 10.

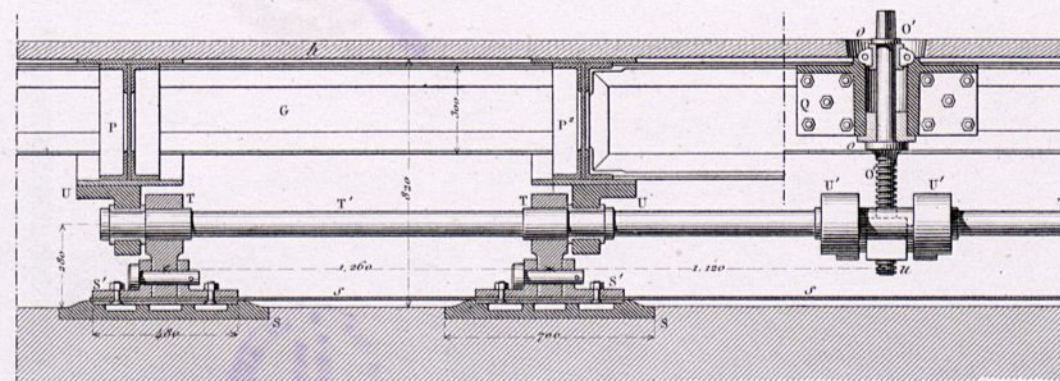

Fig. 15.

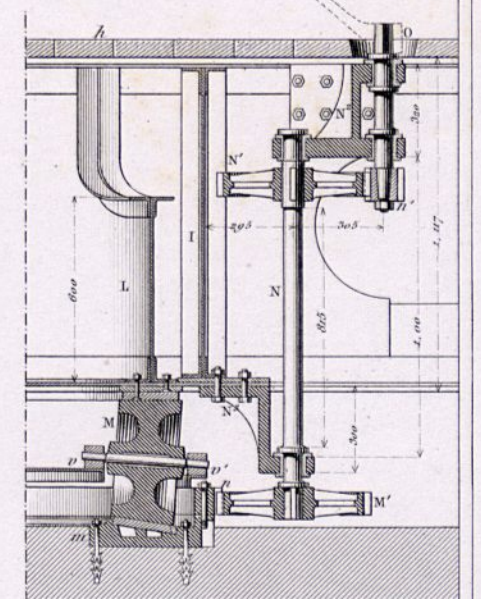

Fig. 9.

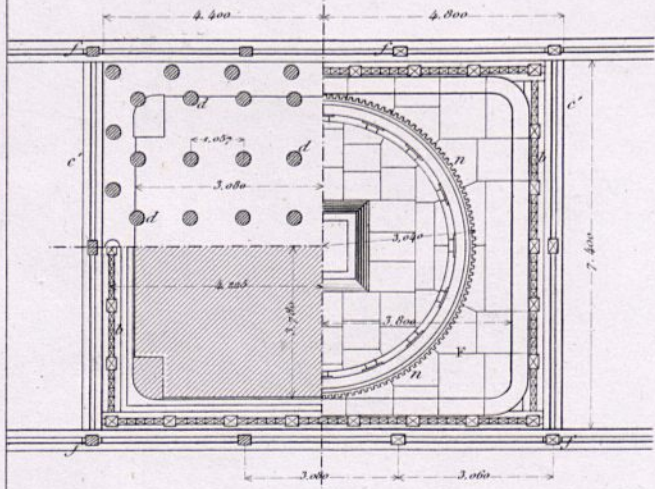

Fig. 16.

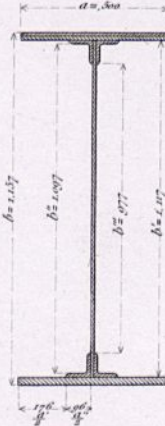

Fig. 17.

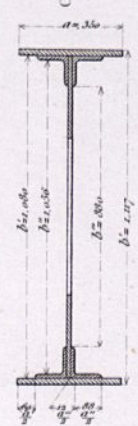

Fig. 18.

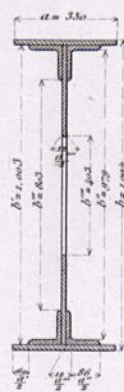

Fig. 19.

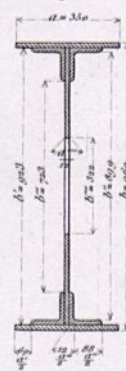

Fig. 20.



Fig. 21.

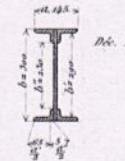
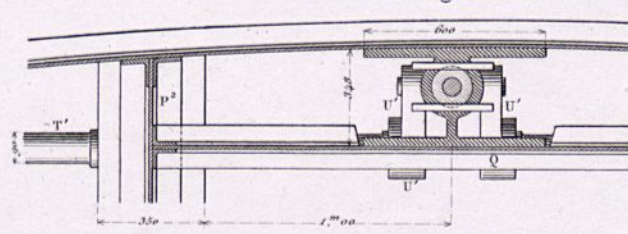

Fig. 12.



Echelle de 1/25 pour les Fig. 10 à 21.

Echelle de 1/50 pour les Fig. 6, 8 et 9.

Fig. 15.

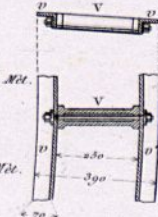
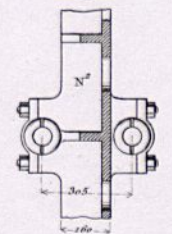

Fig. 14.





Pont tournant sur la Somme, à Abbeville.

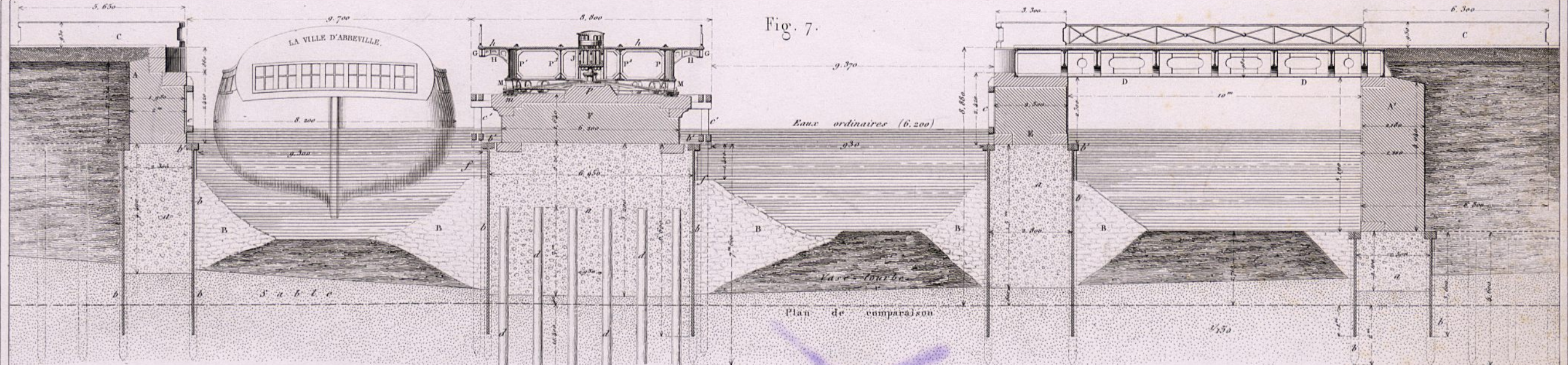

Fig. 2. Pont sur le Canal de S.^t Denis.

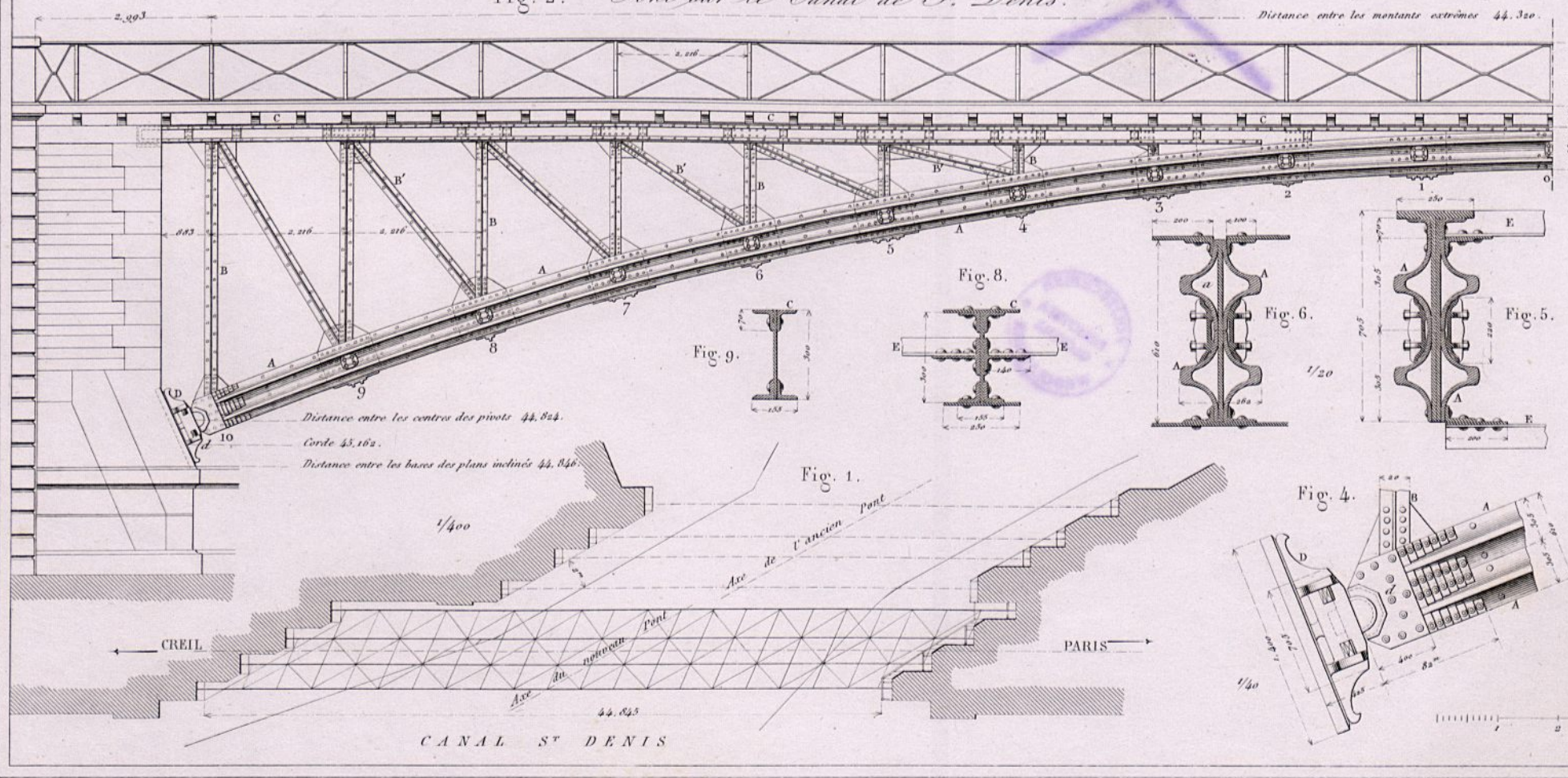
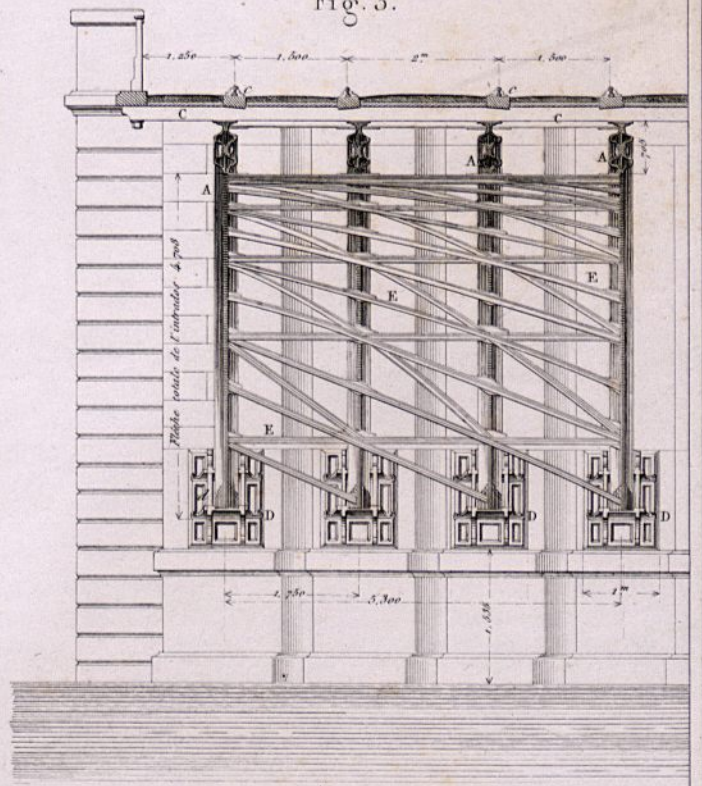
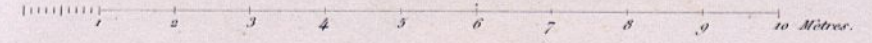

Fig. 3.



Echelle de 1/100 pour les Fig. 2 et 3.





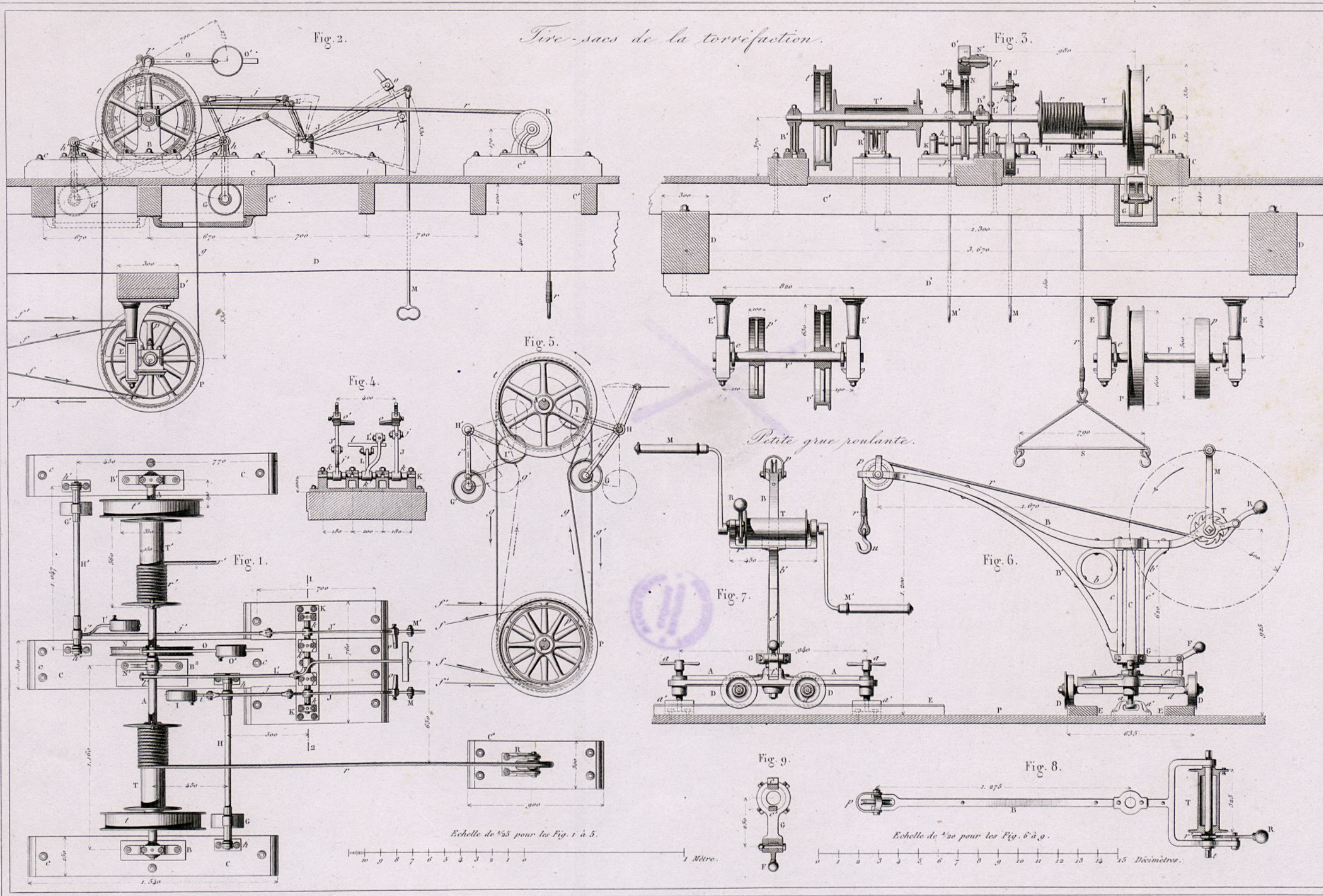



Carbonisation en vases clos.

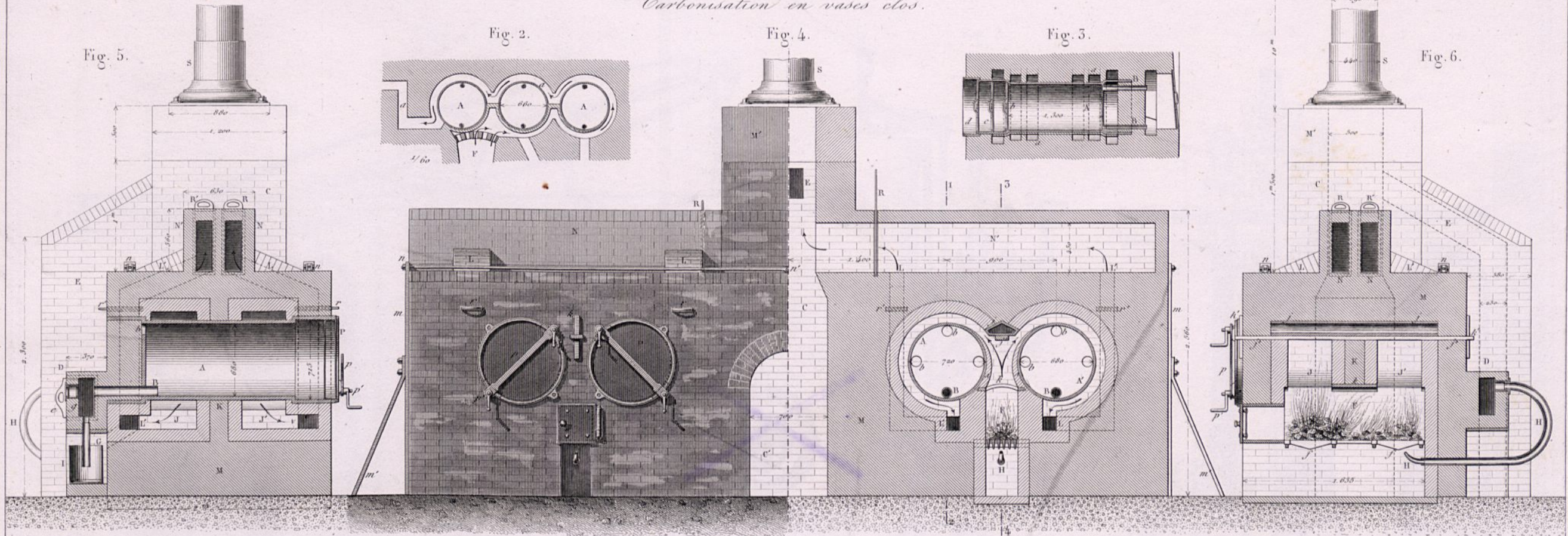

Carbonisation à air libre.

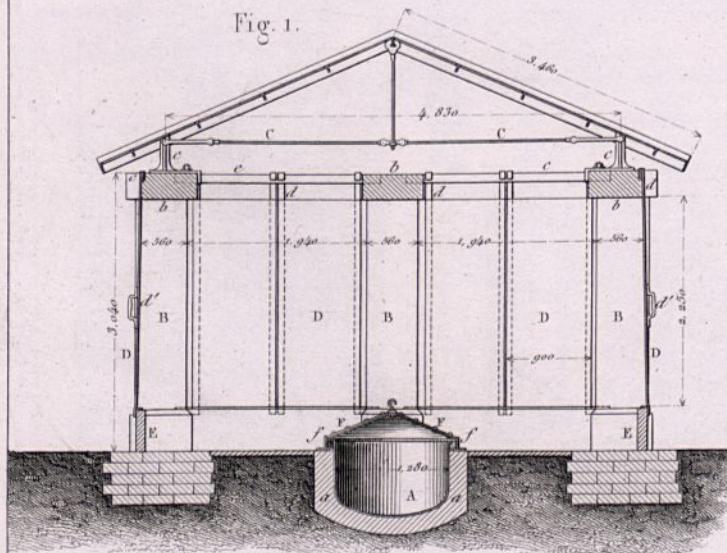

Echelle de 1/80 pour la Fig. 1.

Carbonisation par la vapeur d'eau.

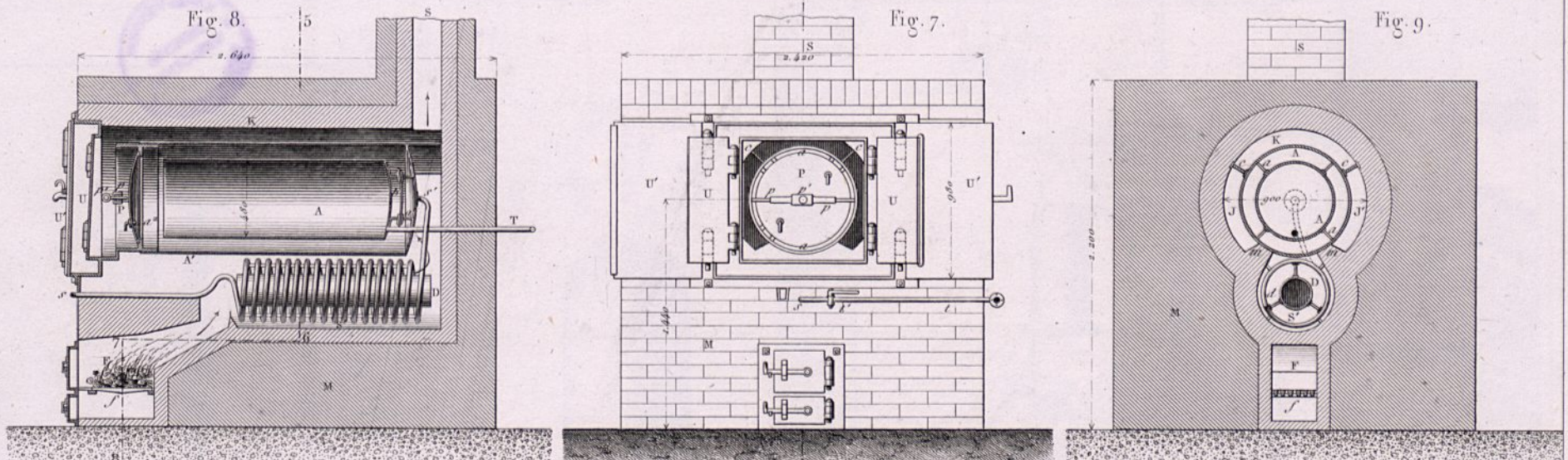

Echelle de 1/40 pour les Fig. 7 à 9.



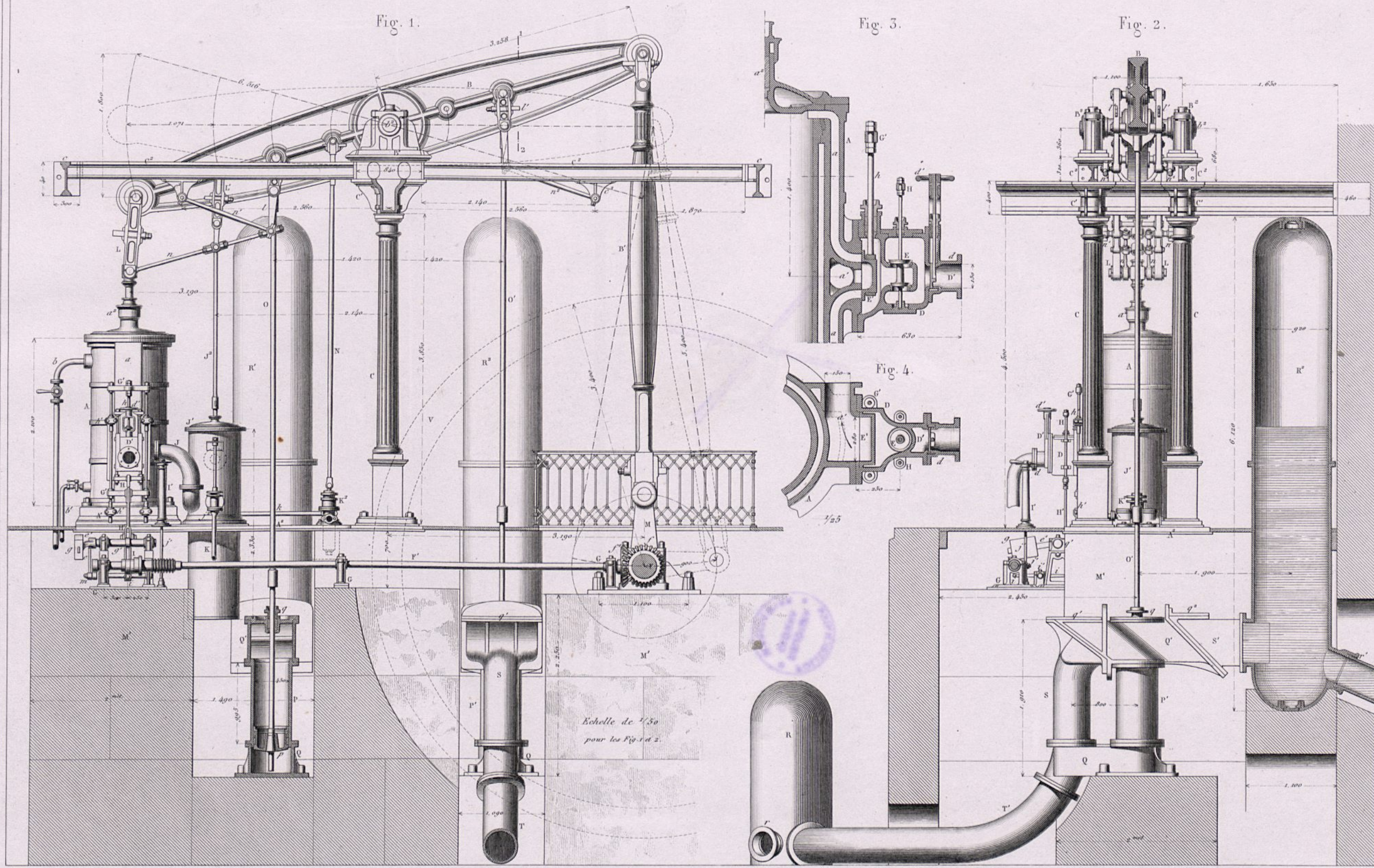



Pompe de la C. des établissements Cavié.

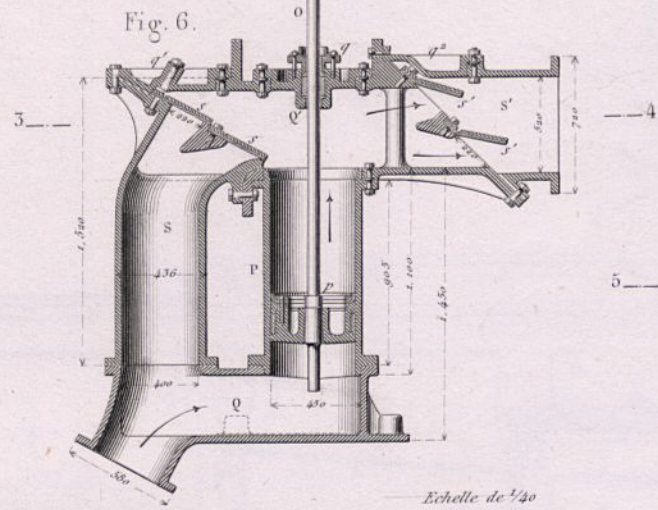

Système de M. Cordier.

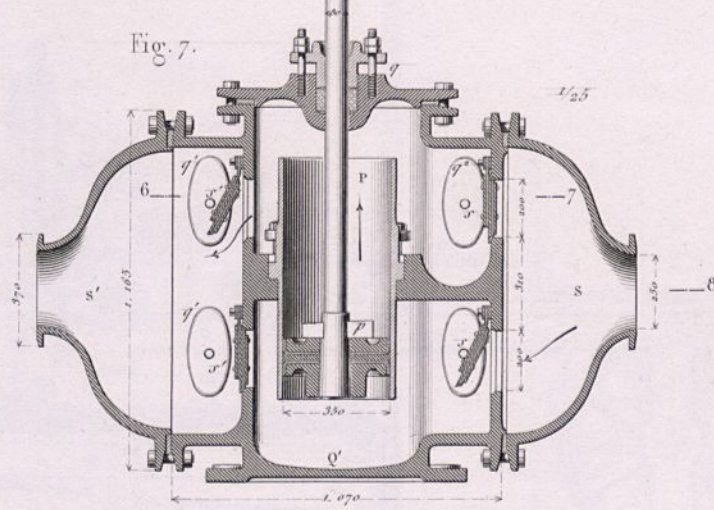

Pompe de M. Farcot.

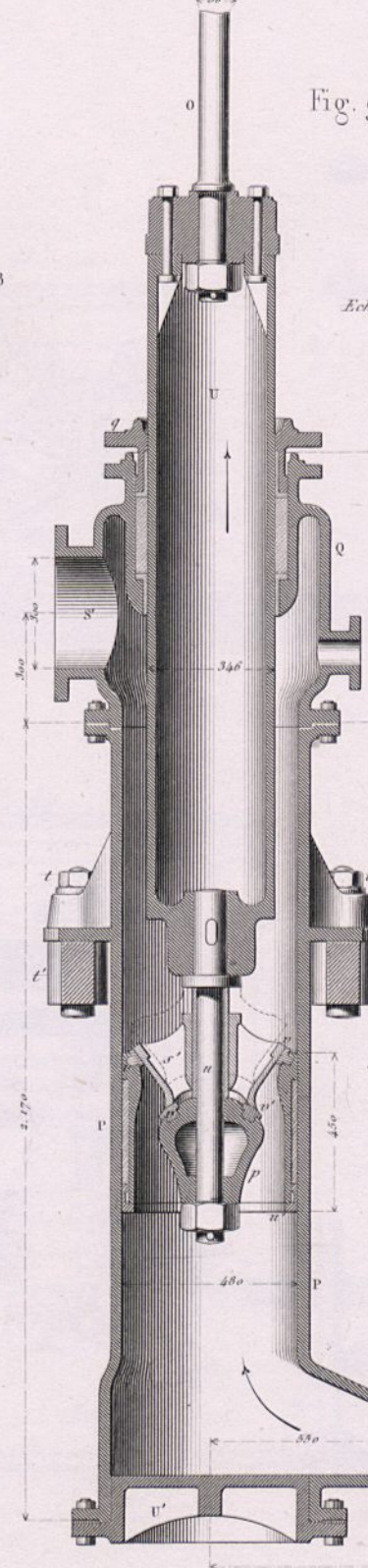

Ancienne pompe de Marly.

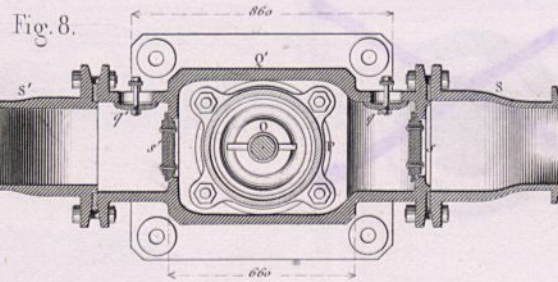
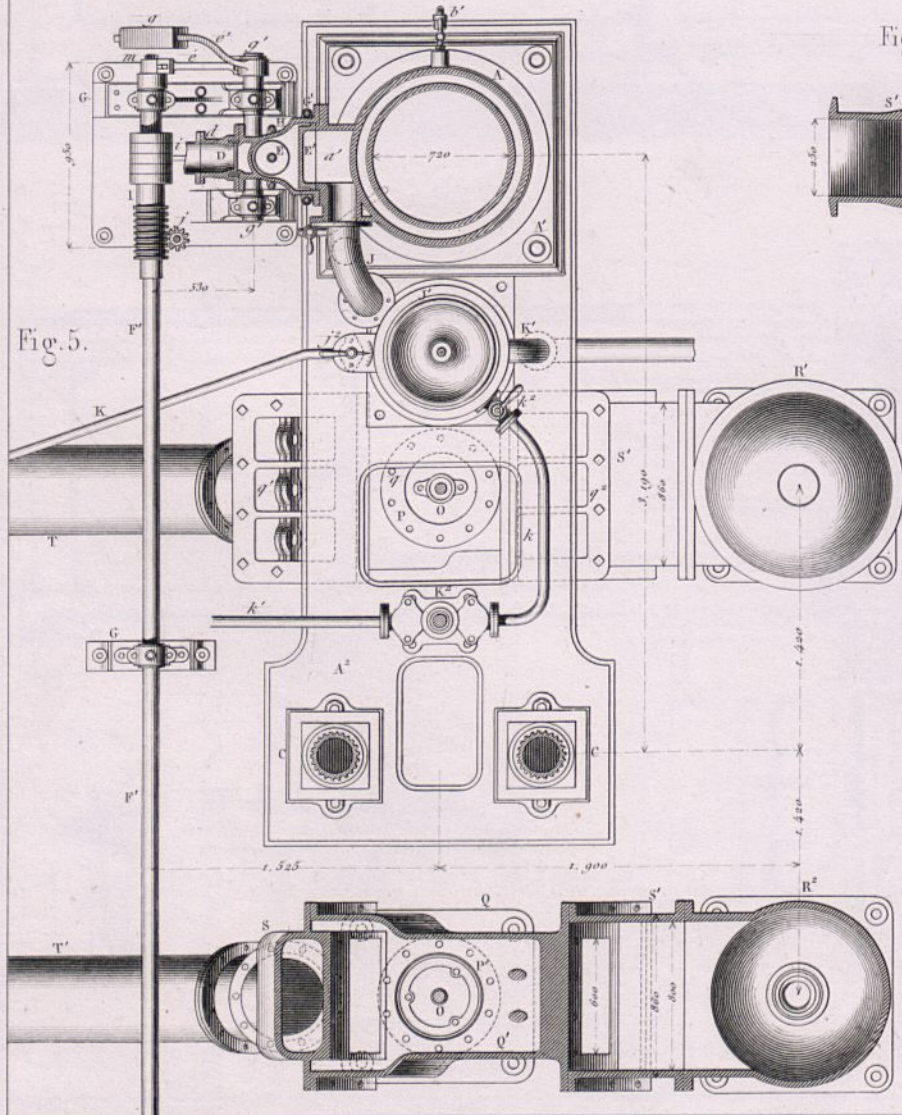
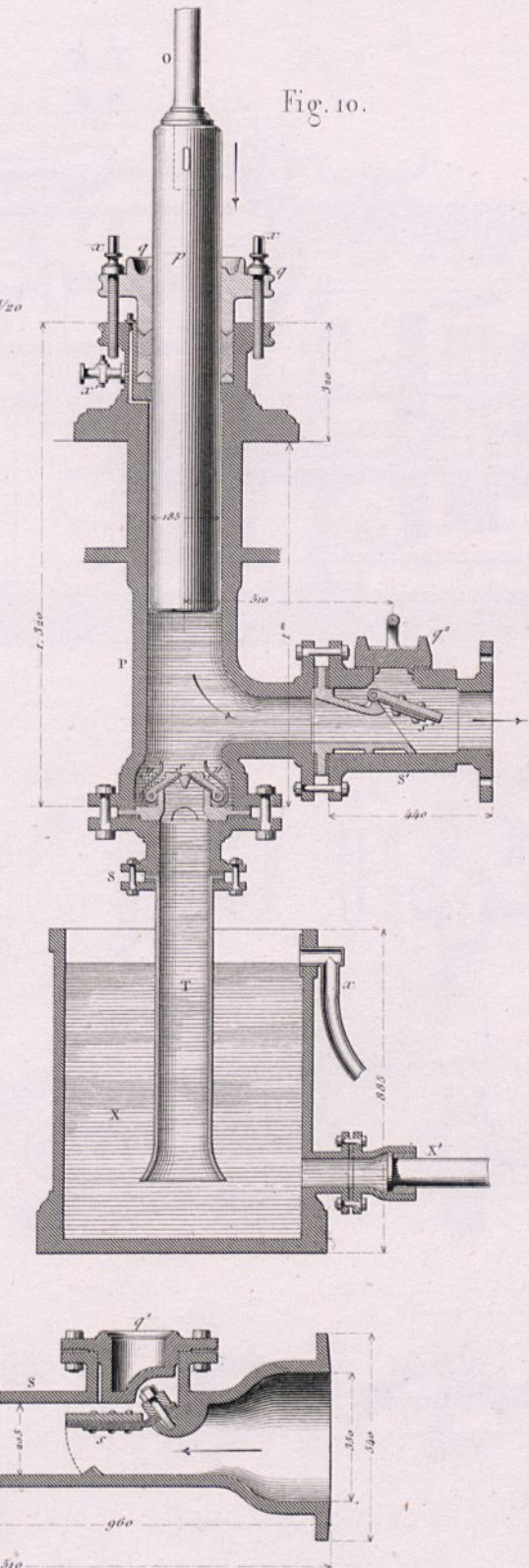

Pompe des machines de Berlin.

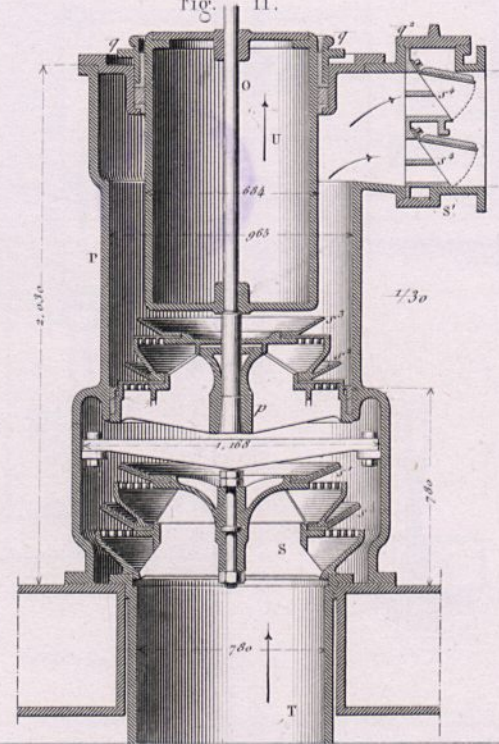



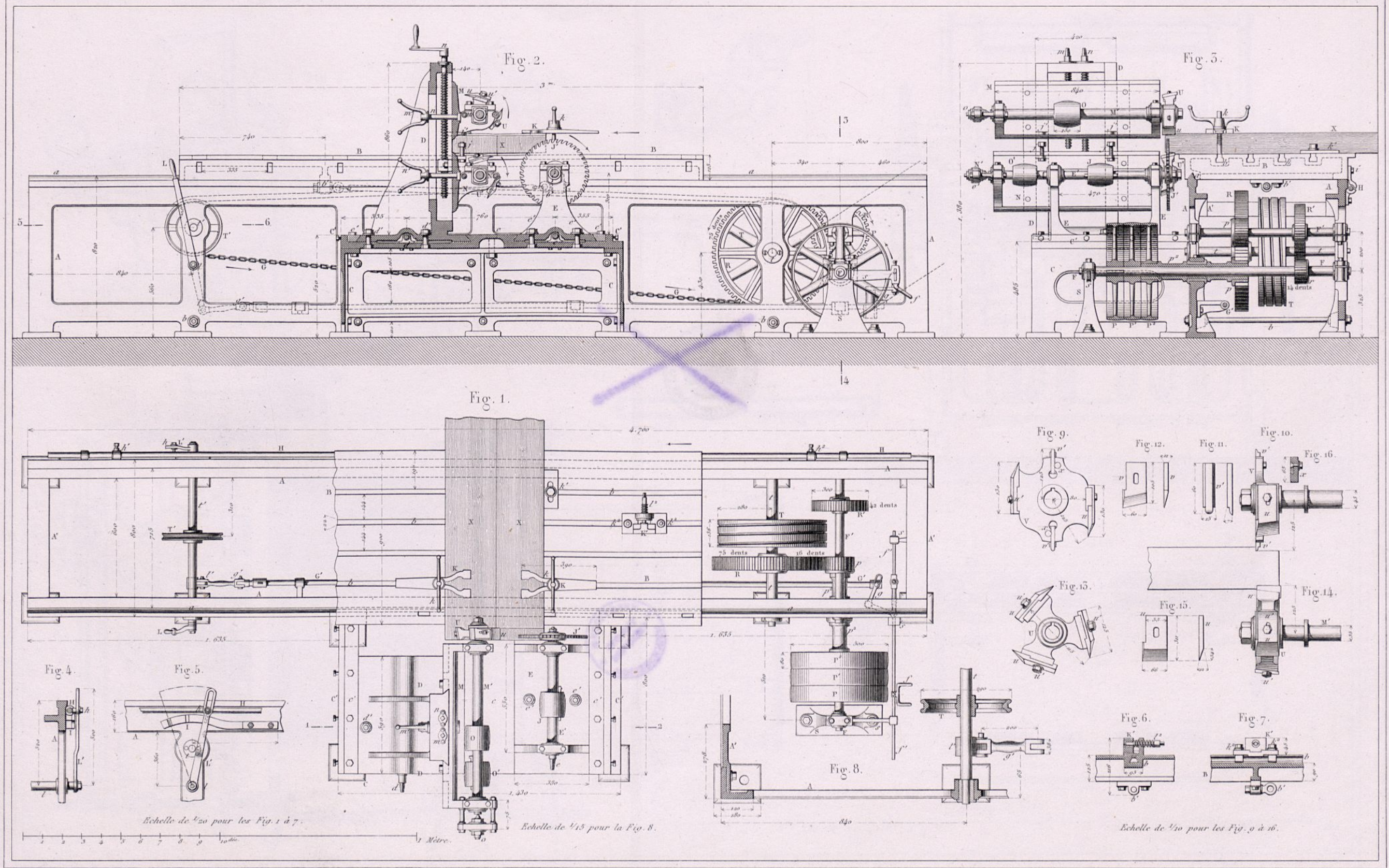



Fig. 3.

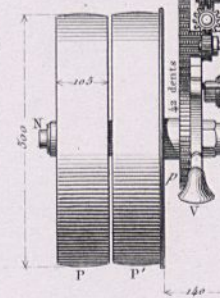
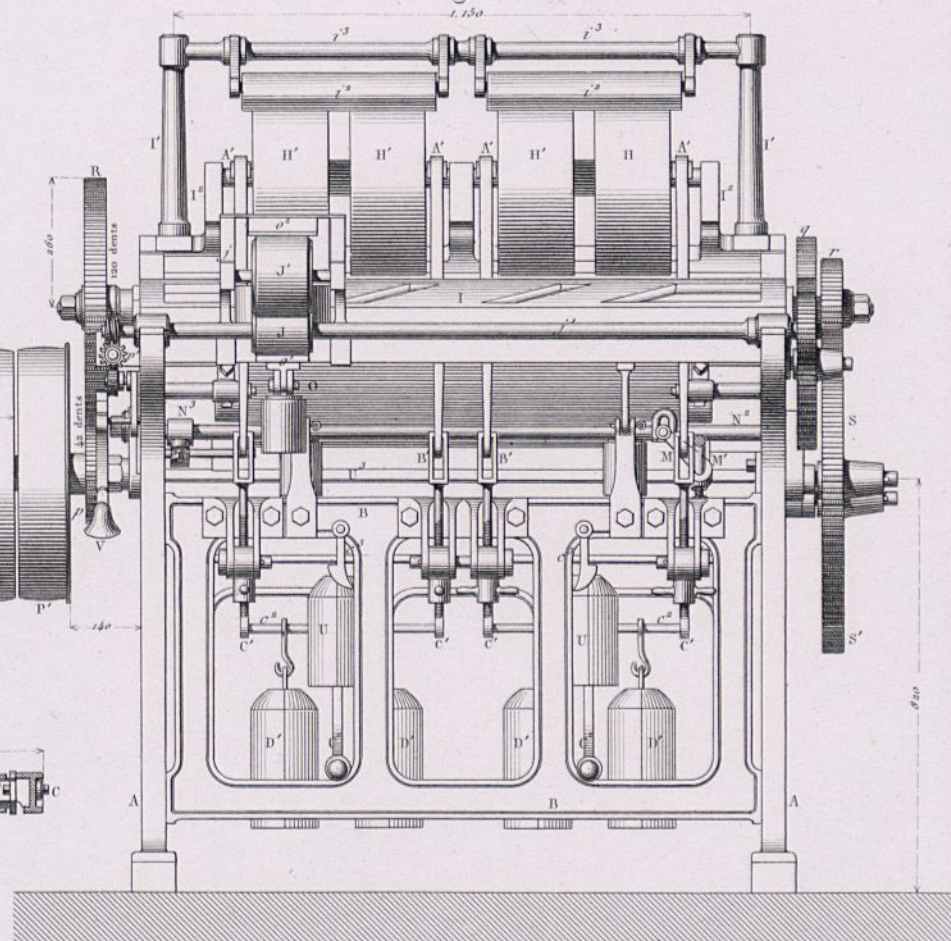

Fig. 10.

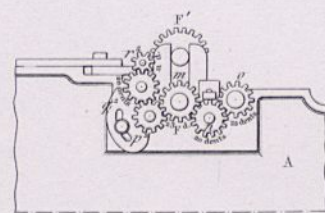

Fig. 9.

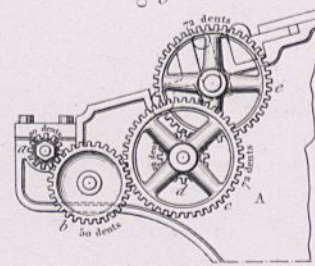

Fig. 2.

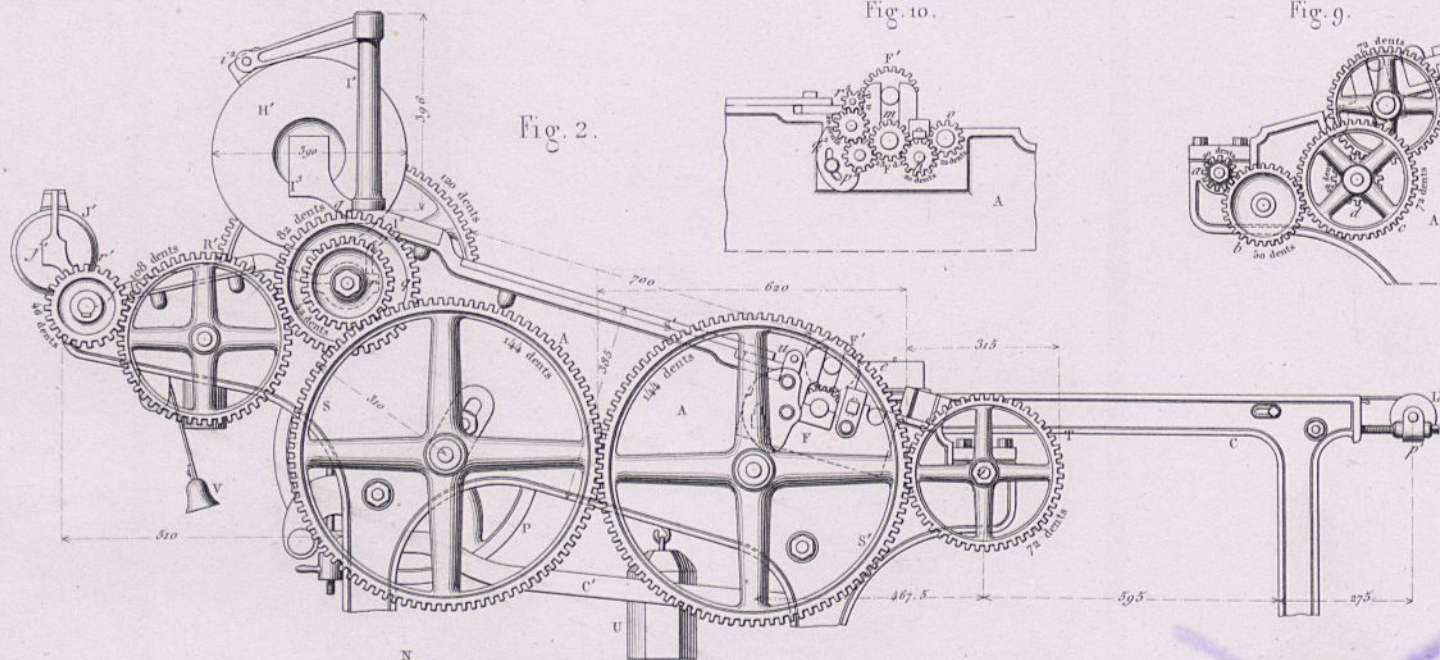

Fig. 11.

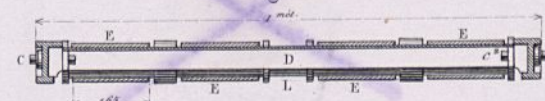

Fig. 1.

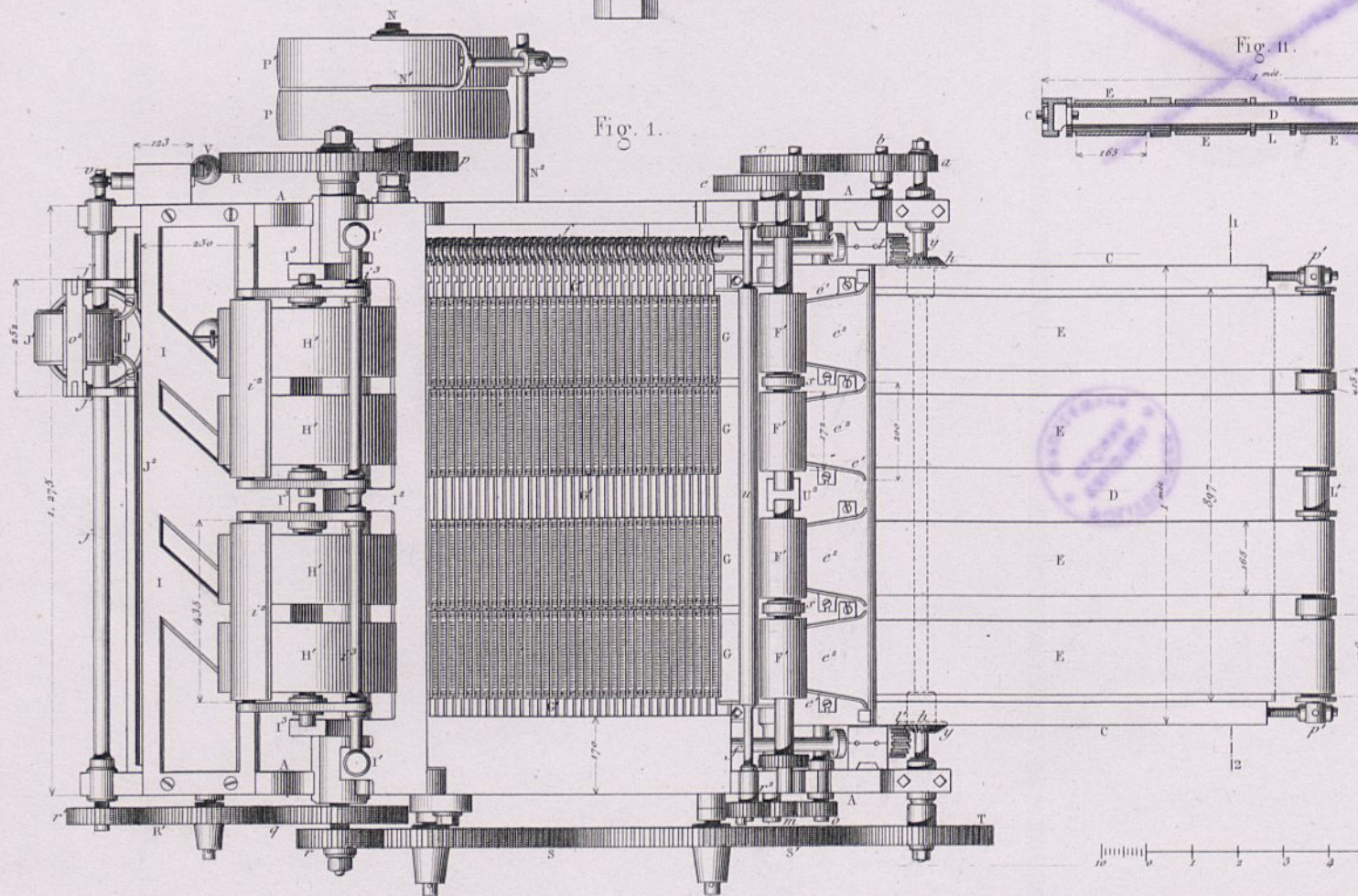

Fig. 12.

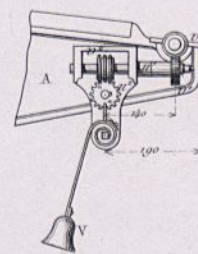

Fig. 7.

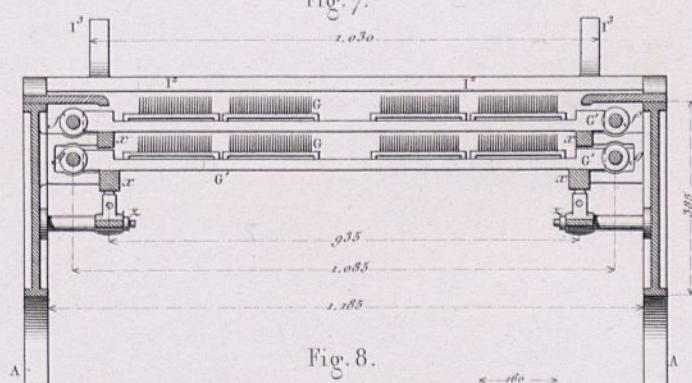
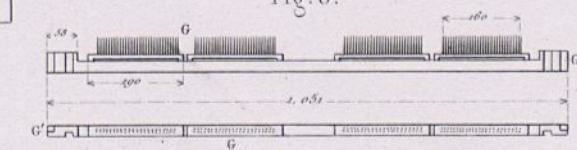
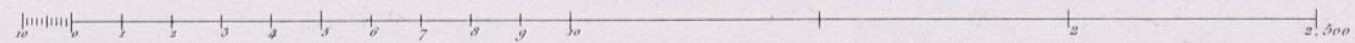

Fig. 8.



Echelle de 1/15





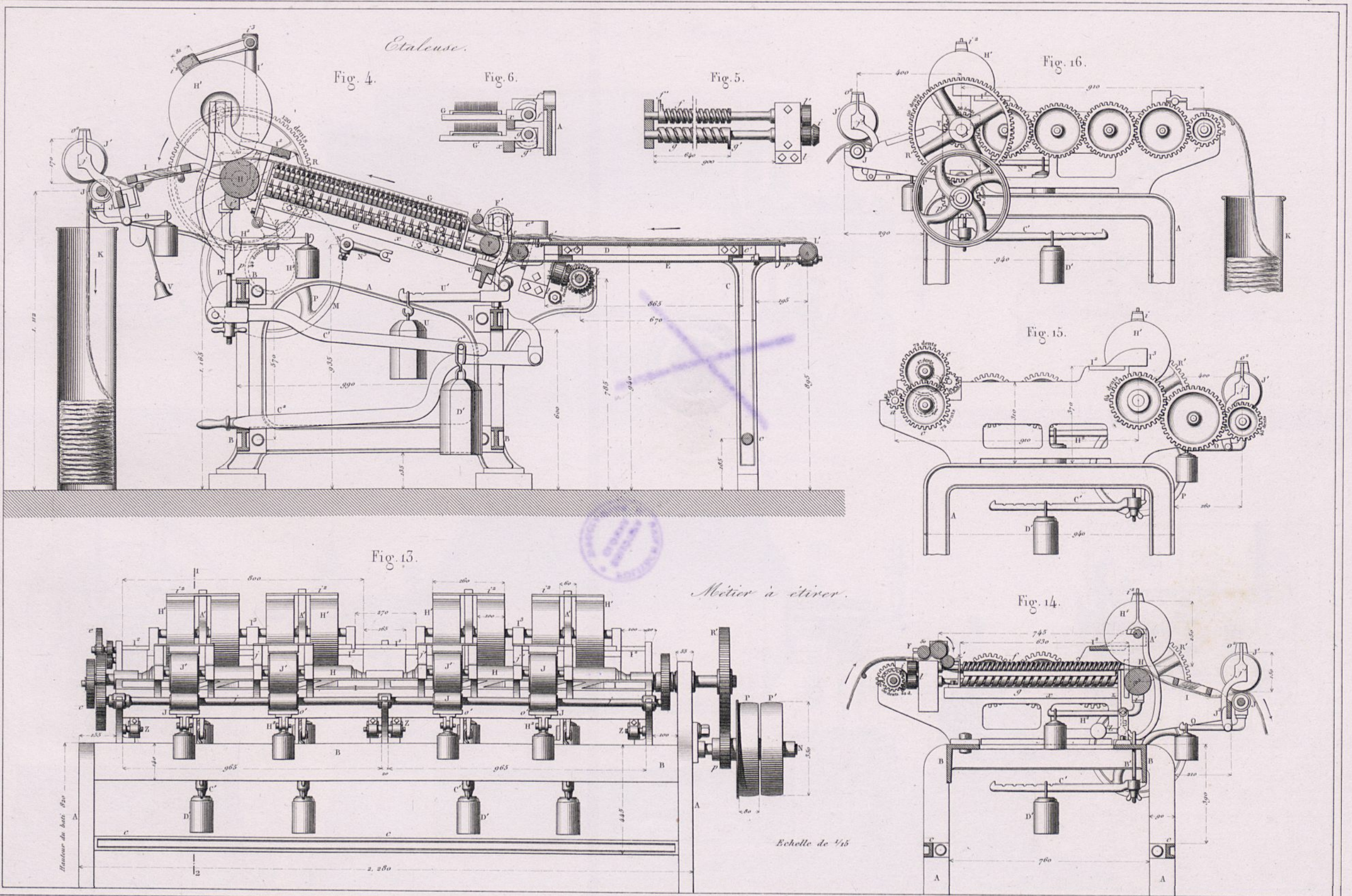

Étaleuse.

Fig. 4.

Fig. 6.

Fig. 5.

Fig. 16.

Fig. 15.

Fig. 13.

Métier à étirer.

Fig. 14.

Echelle de 1/15



Chaudière rotative, par M. A. de Montgolfier.

Fig. 5.

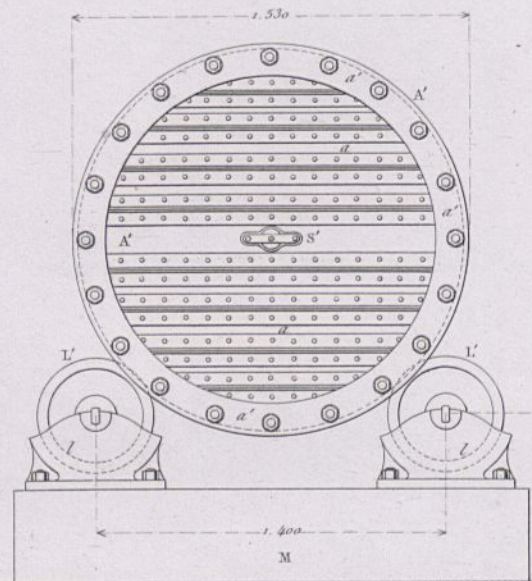

Fig. 4.

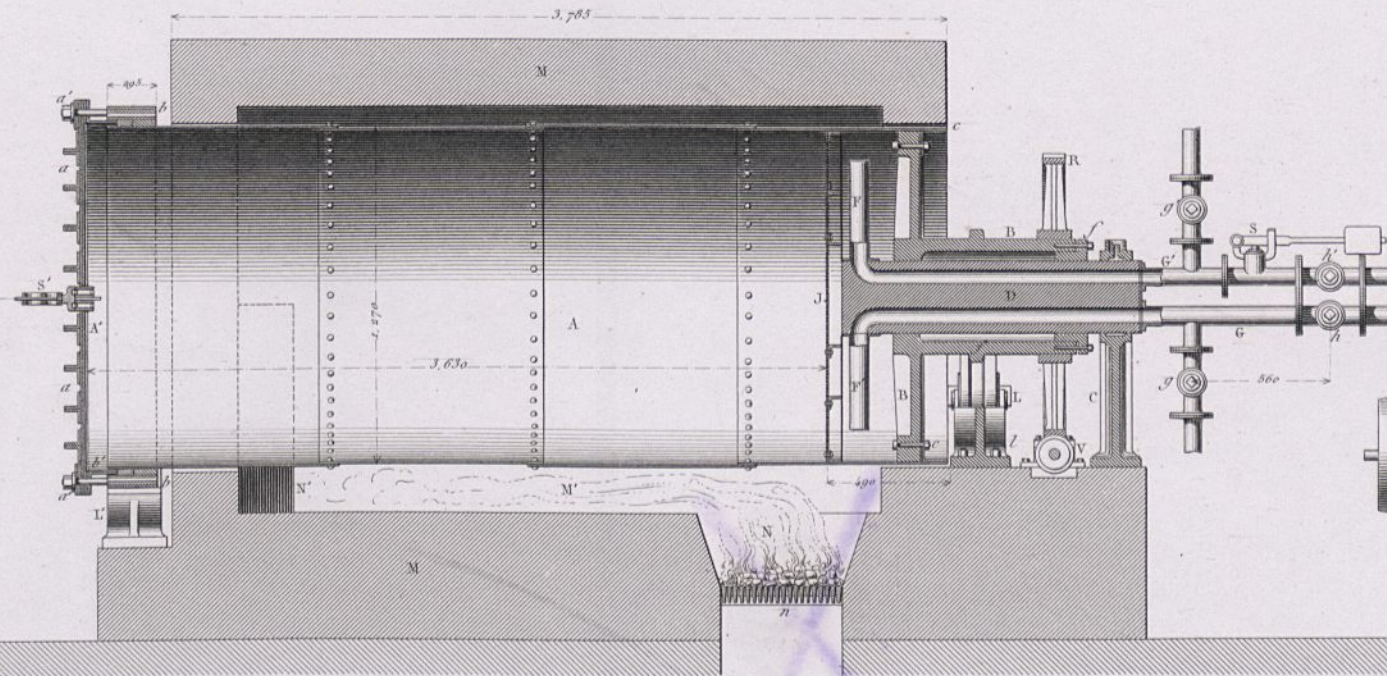
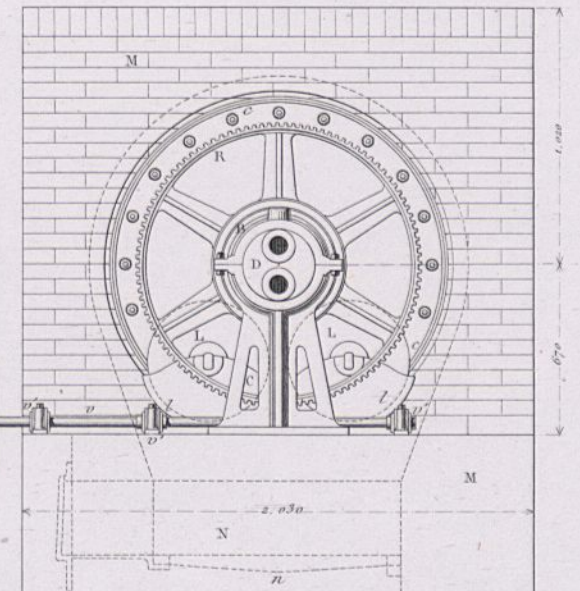

Fig. 6.



Cylindre lessiveur, par M. G. Planche et Rieder.

Fig. 2.

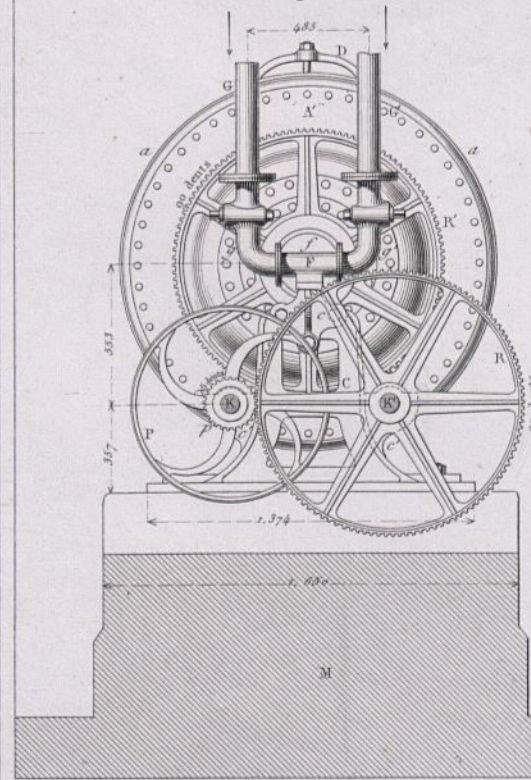

Fig. 1.

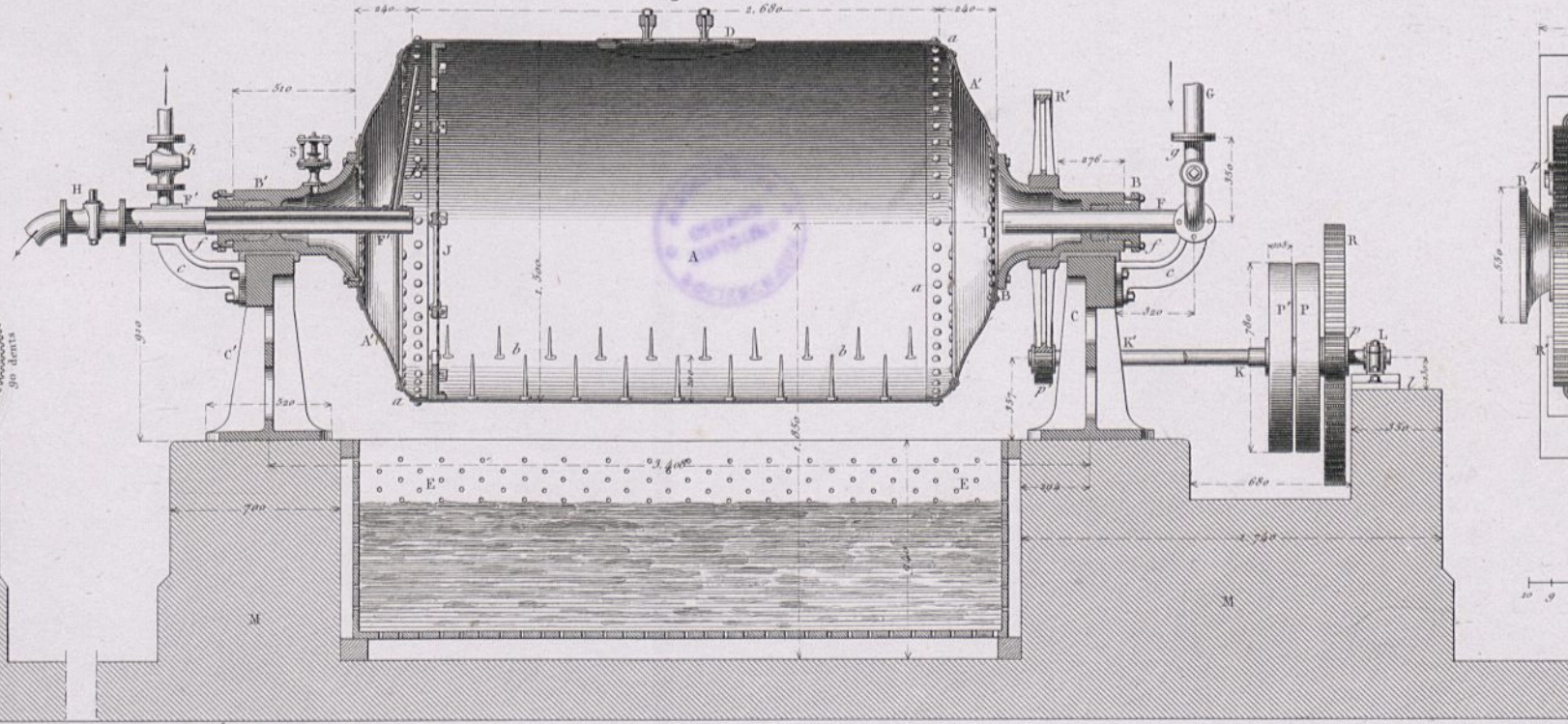
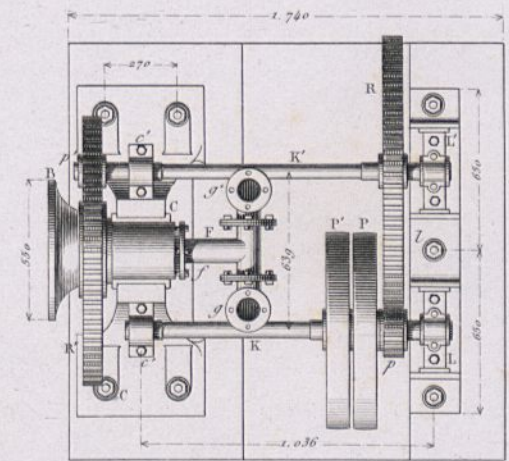

Fig. 3.



Echelle de 1/30.

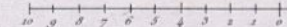



Fig. 1.

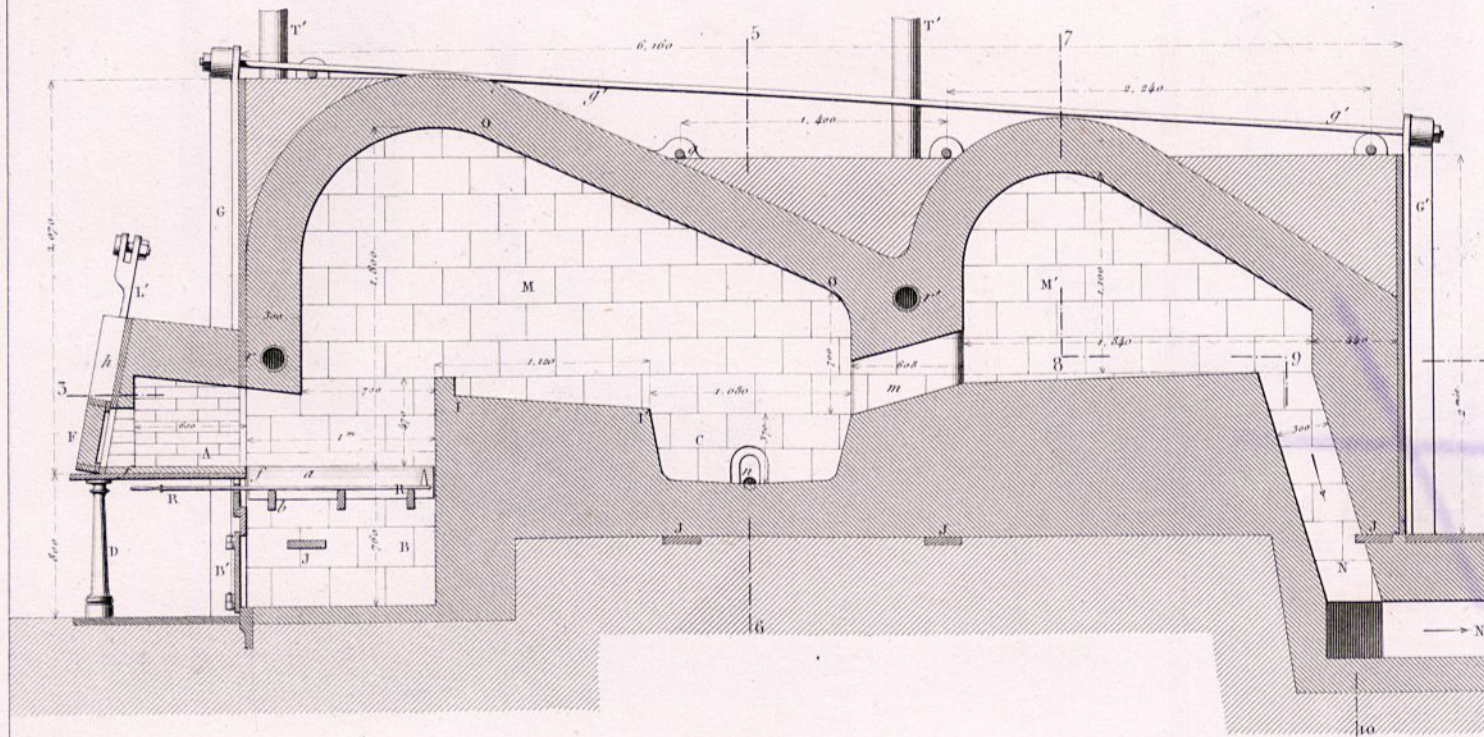

Fig. 2.

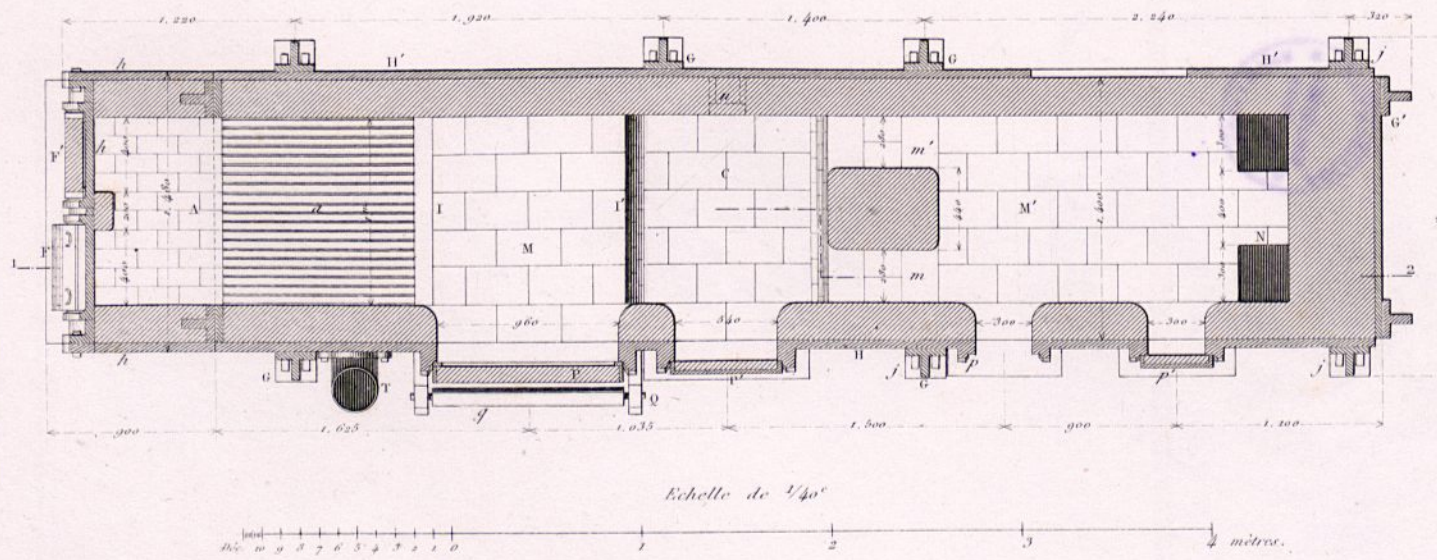

Fig. 3.

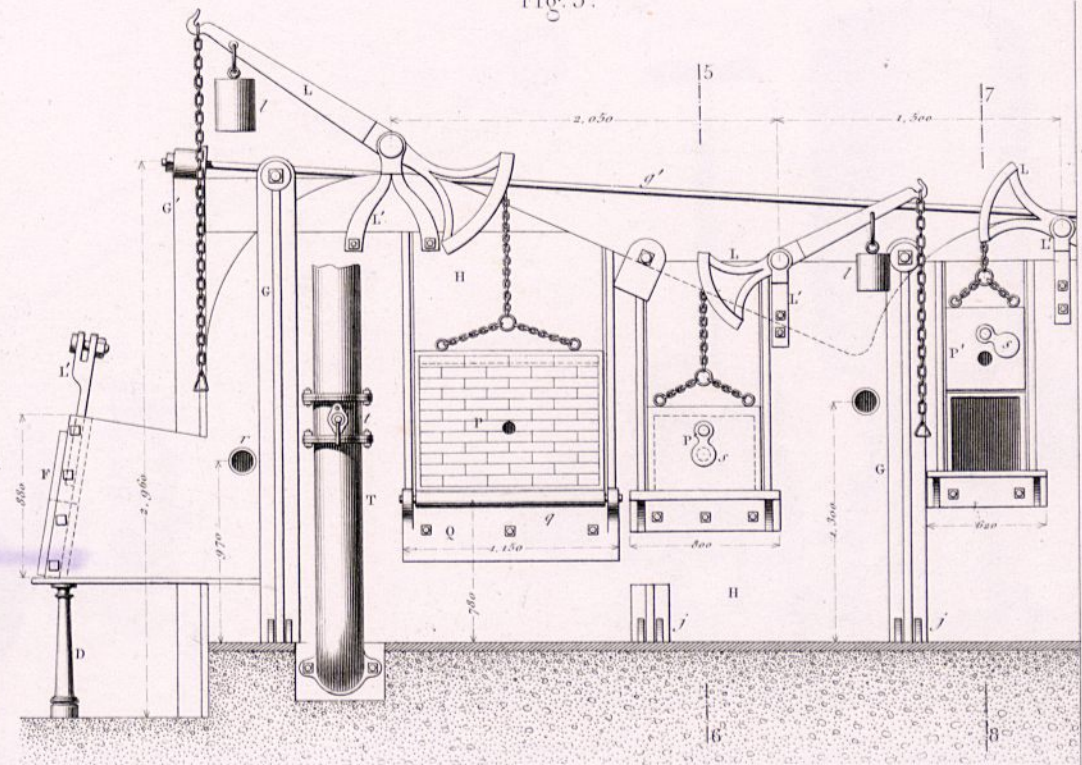

Fig. 4.

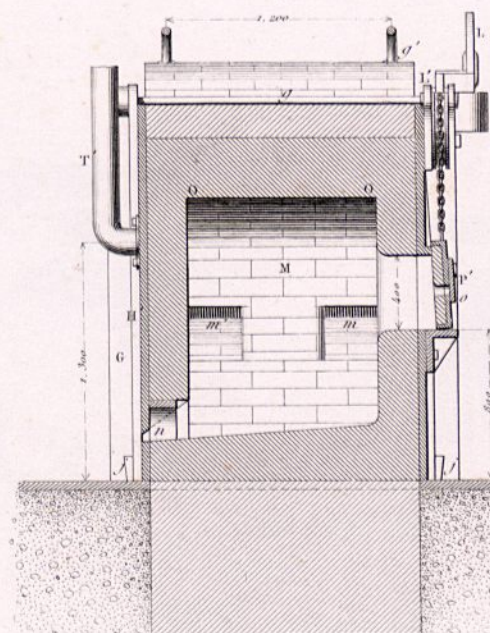
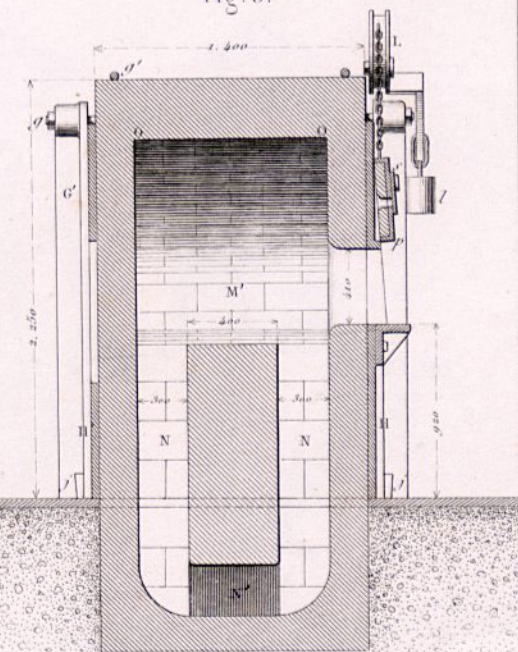
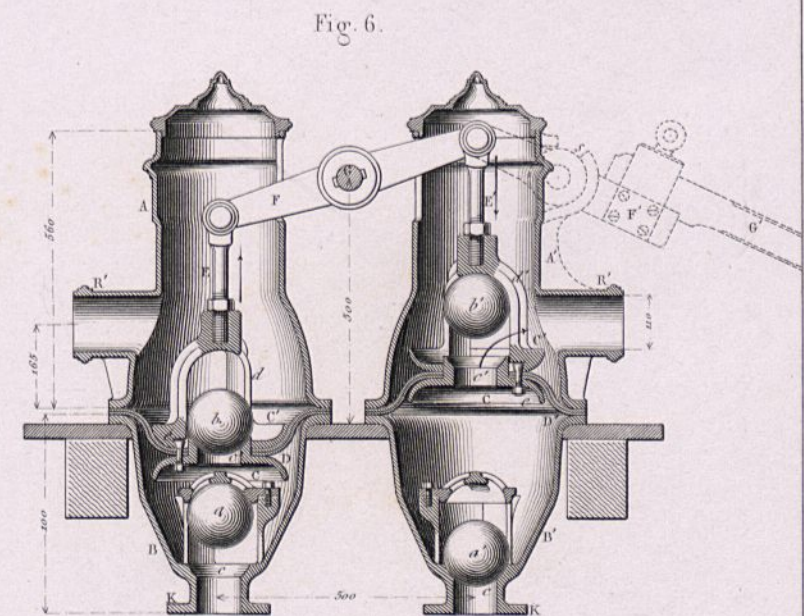
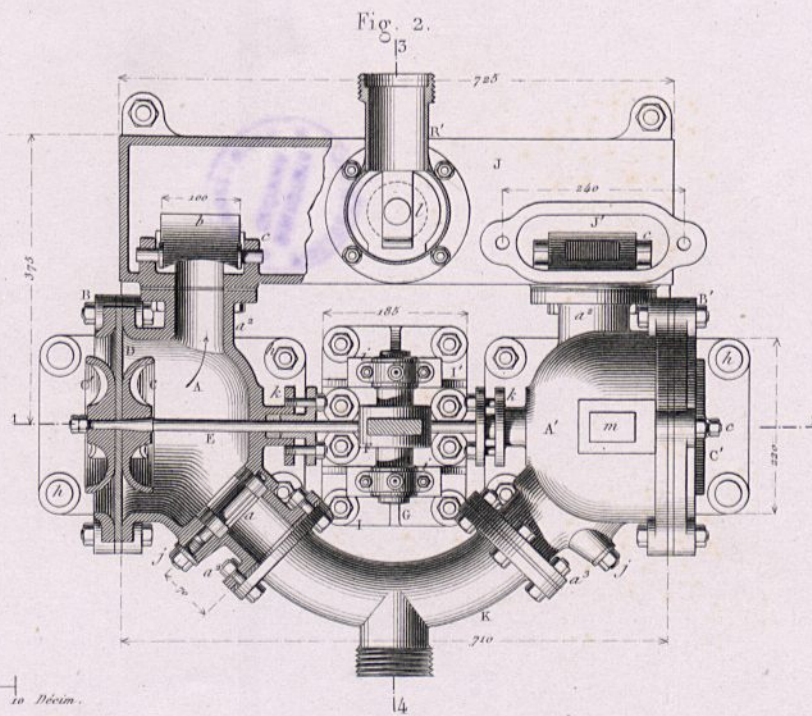
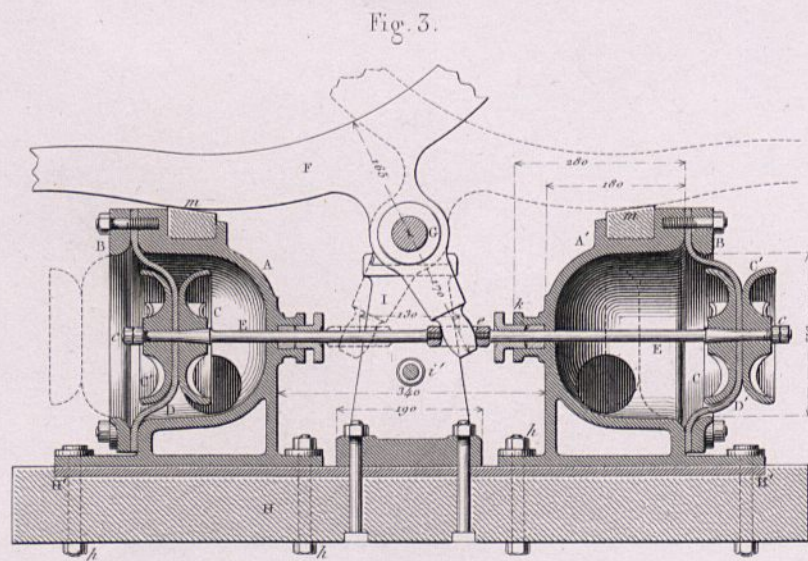
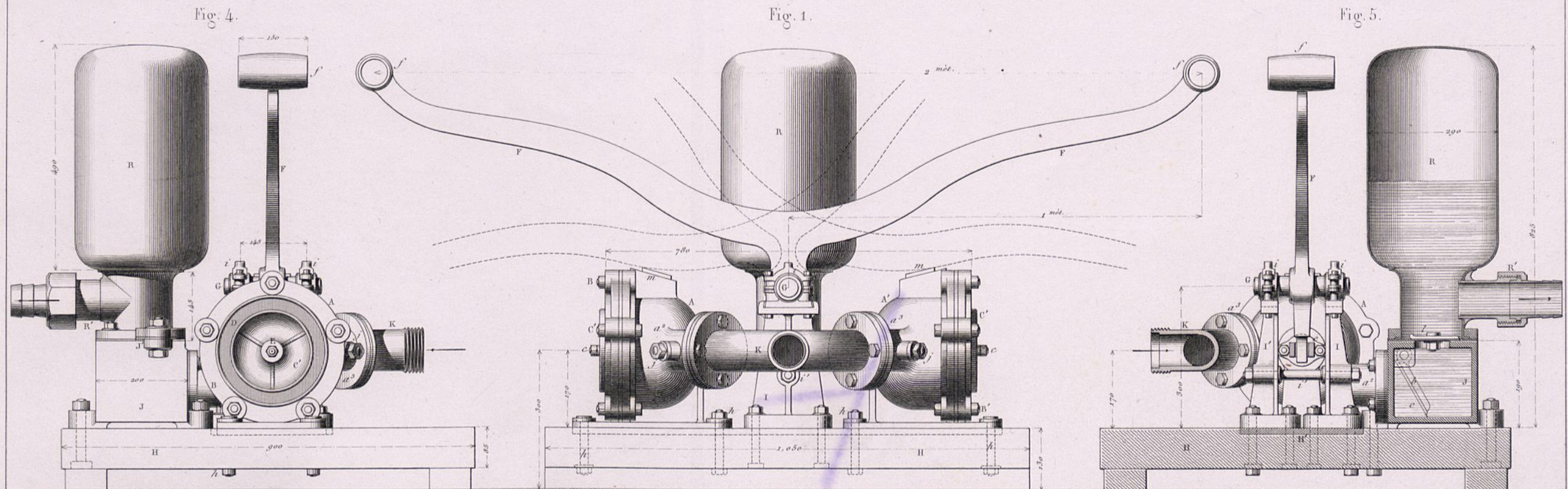

Fig. 5.







Echelle de 1/50 pour les Fig. 1 à 3.

Echelle de 1/50 pour la Fig. 6.

Cent. 10 5 0 1 2 3 4 5 6 7 8 9 10 Décim.

Cent. 10 5 0 1 2 3 4 5 6 7 8 9 10



Patouillet à Siphon déversoir, par M. Viry.

Fig. 1.

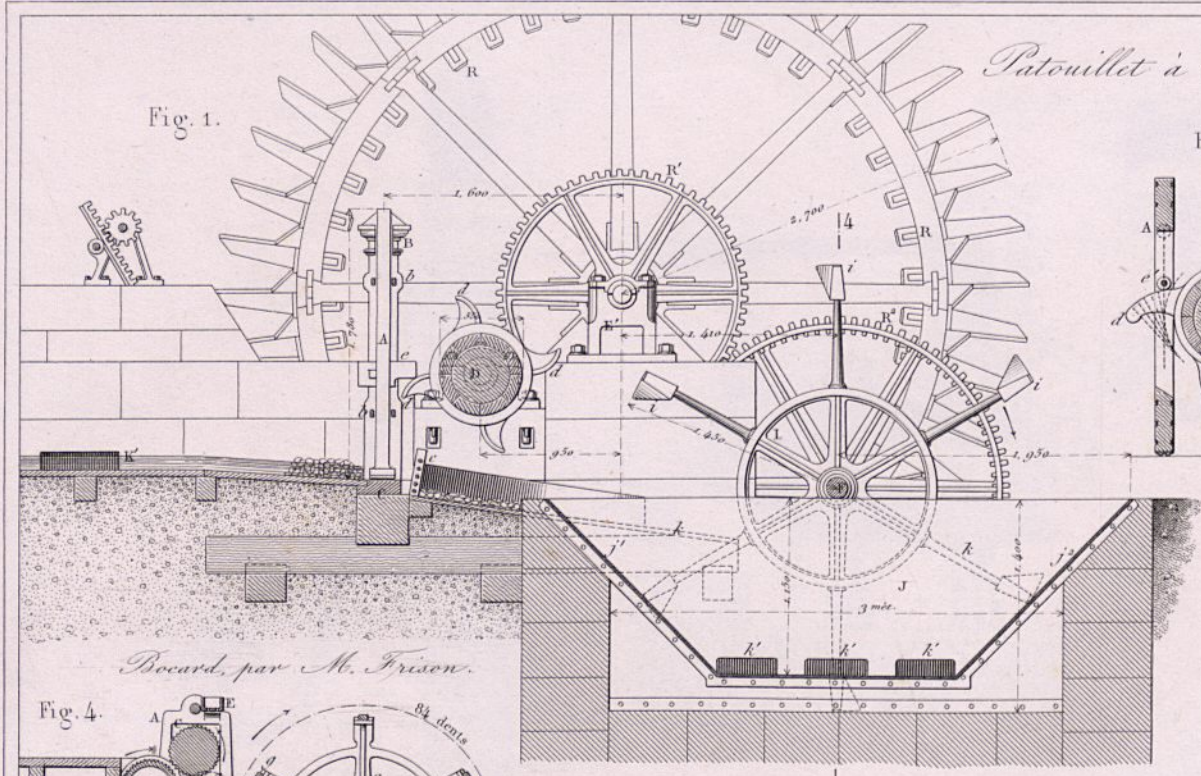

Fig. 3.

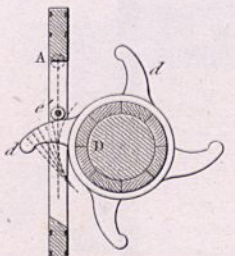
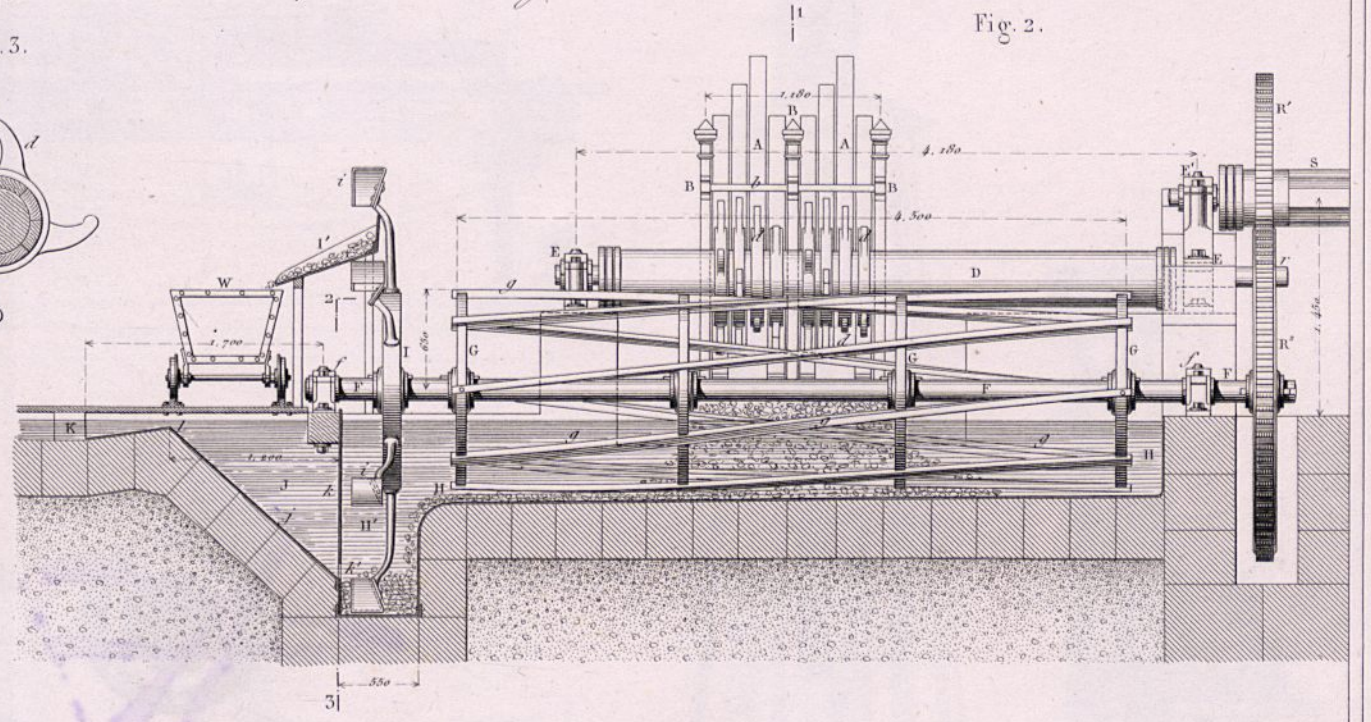
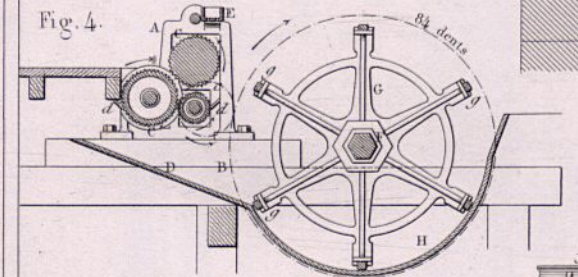

Fig. 2.



Bocard, par M. Frison.

Fig. 4.



Laveur rotatif, par M. Le Brun.

Fig. 5.

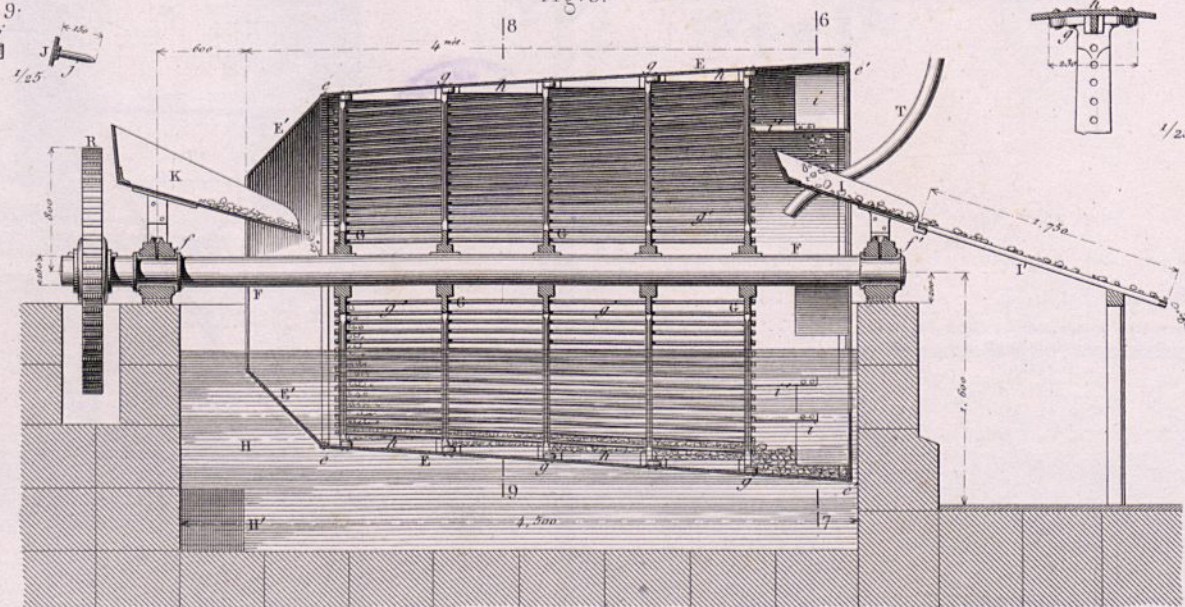

Fig. 8.

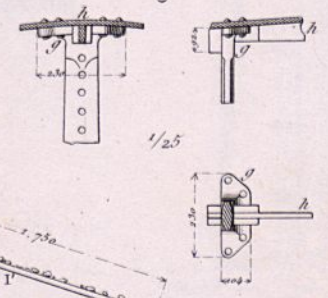

Fig. 6.

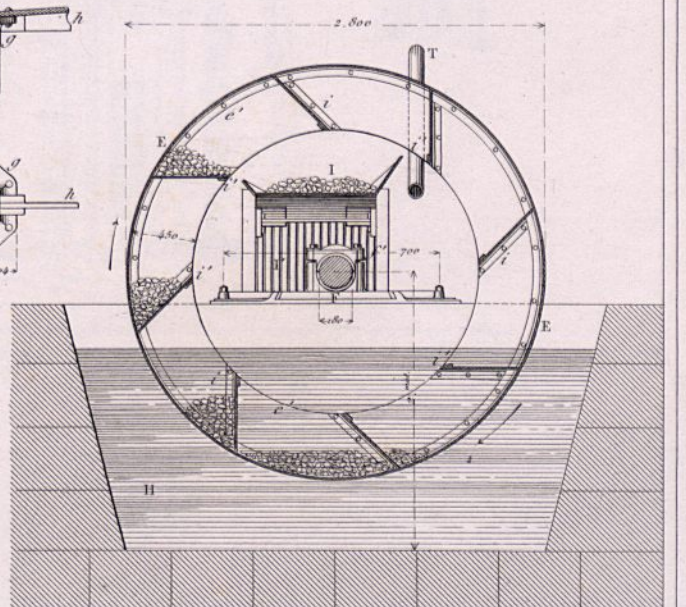
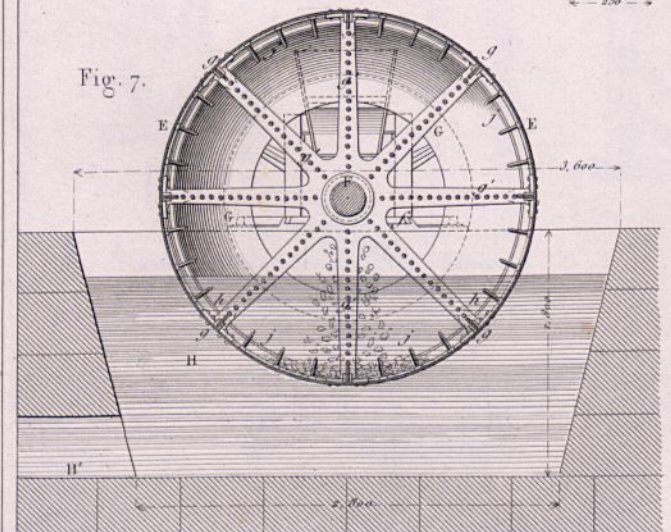
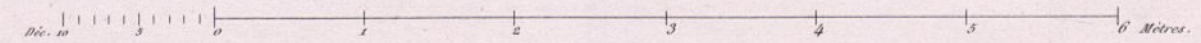

Fig. 7.



Echelle de 1/30 pour les Fig. 1 à 7.





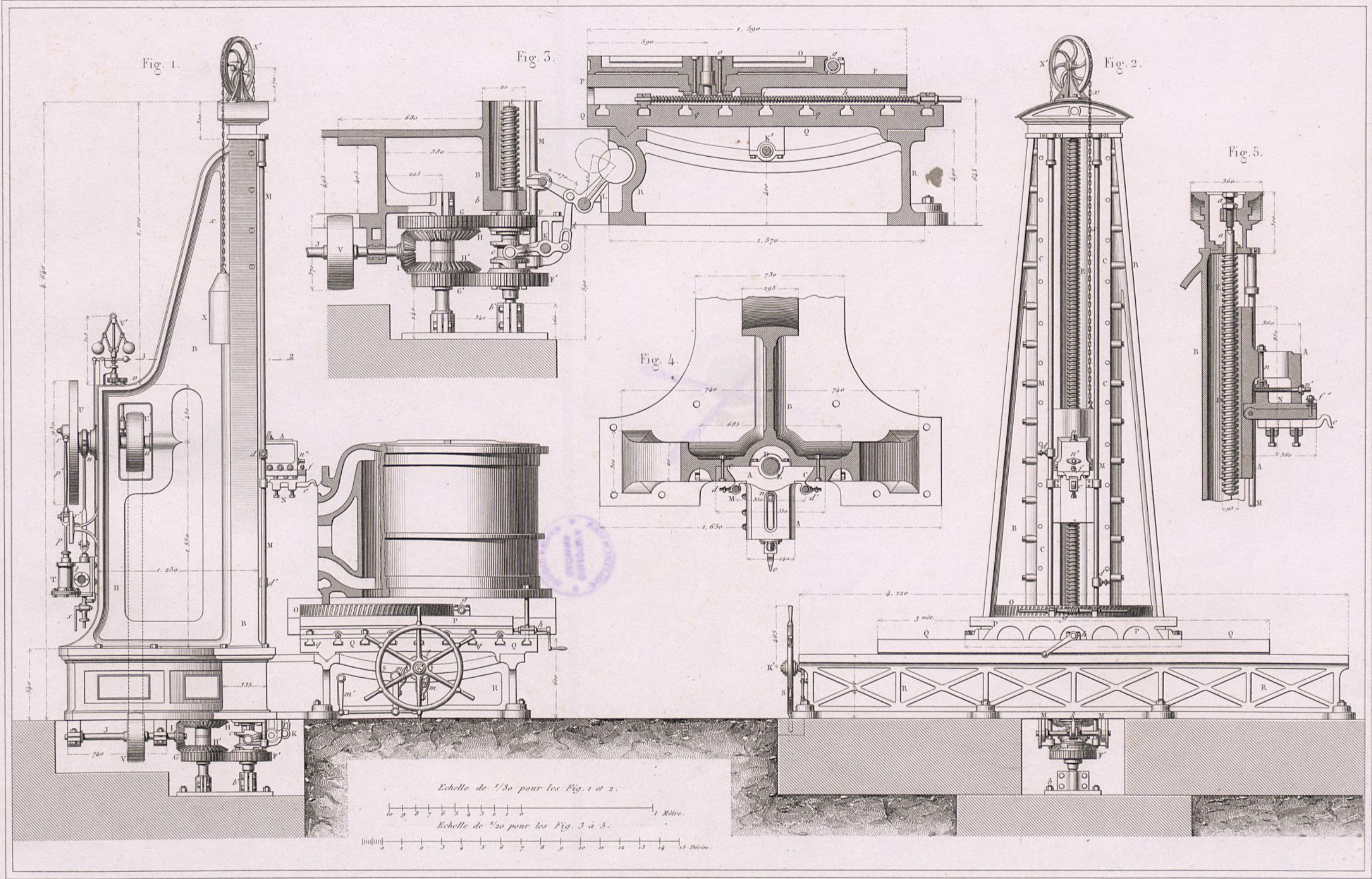

Echelle de 1/30 pour les Fig. 1 et 2.
 Echelle de 1/20 pour les Fig. 3 à 5.

1 Mètre.
 15 Décim.



Fourneau de la poudrerie nationale du Pérou.

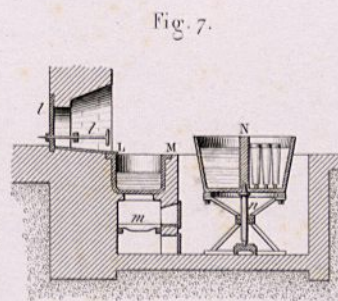
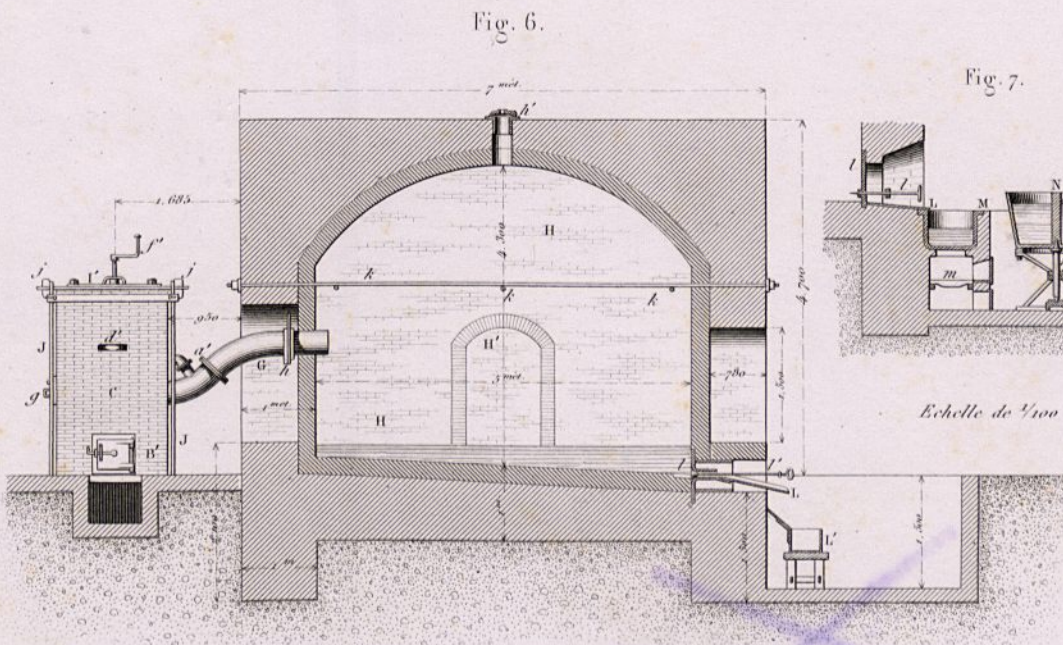
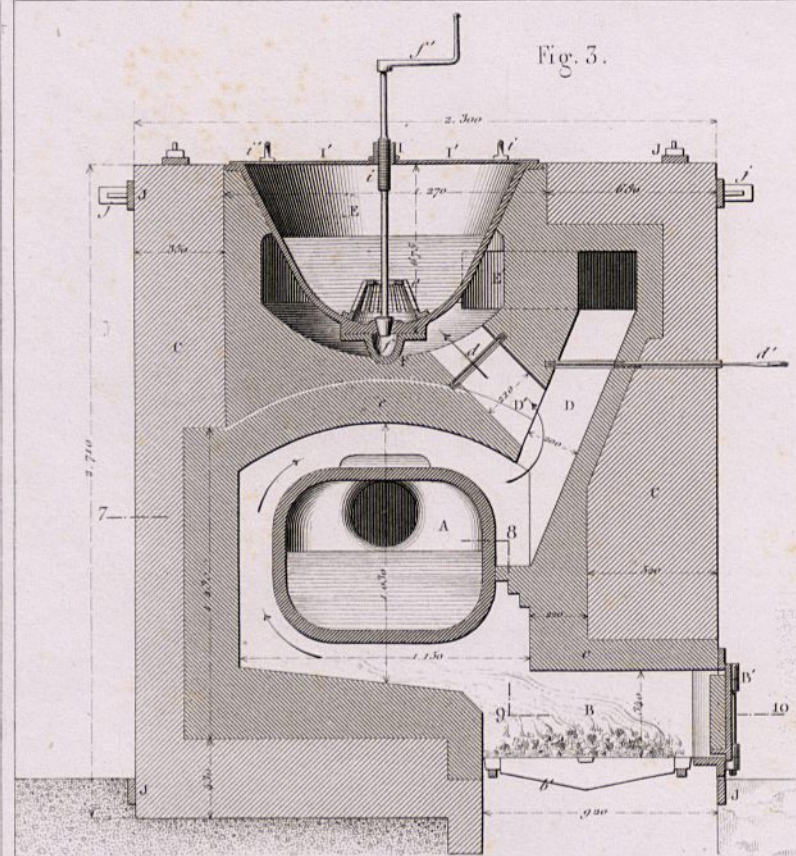

Echelle de 1/100

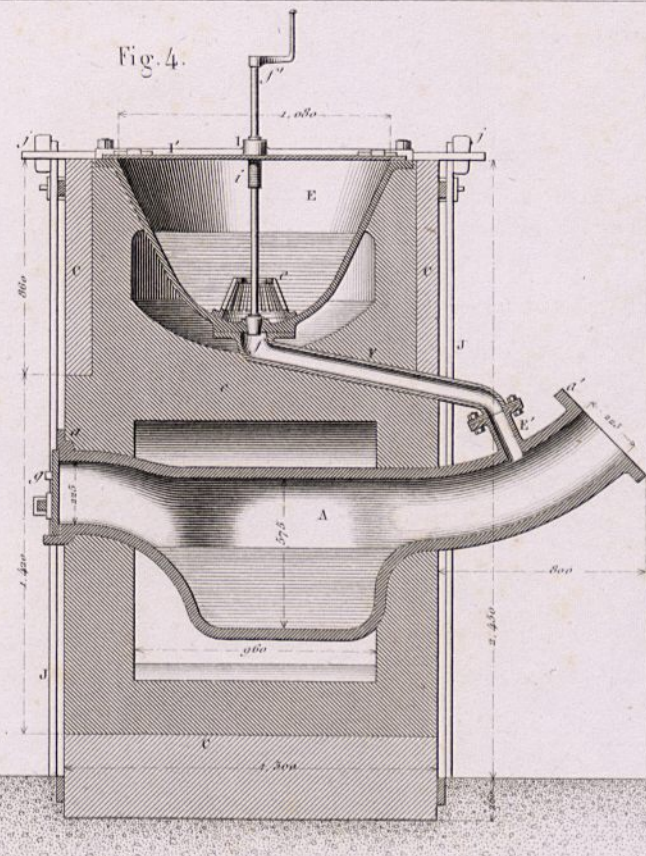

Disposition de M. Clément, établie chez M. Roignaud de Crest.

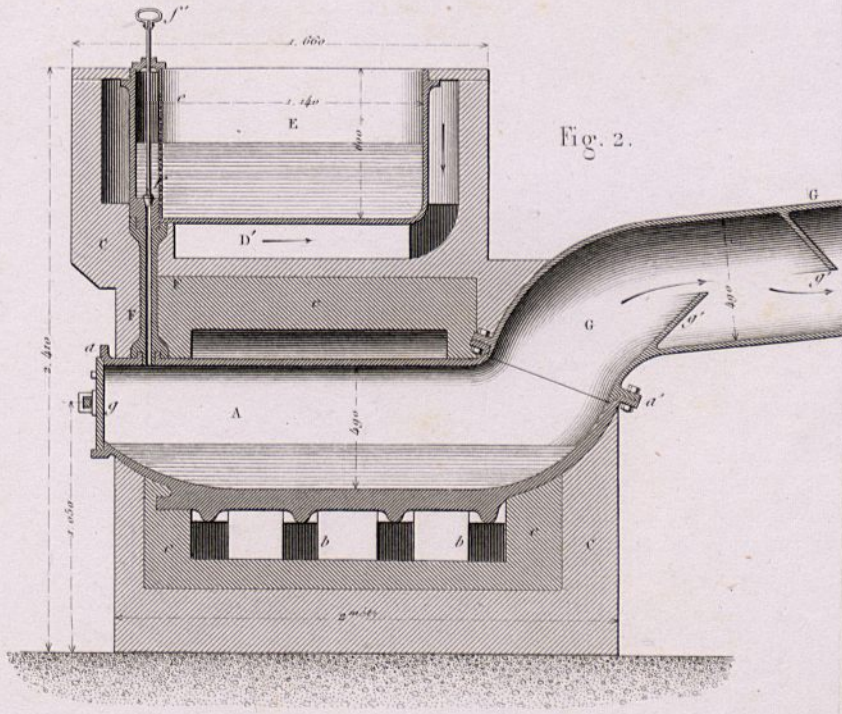
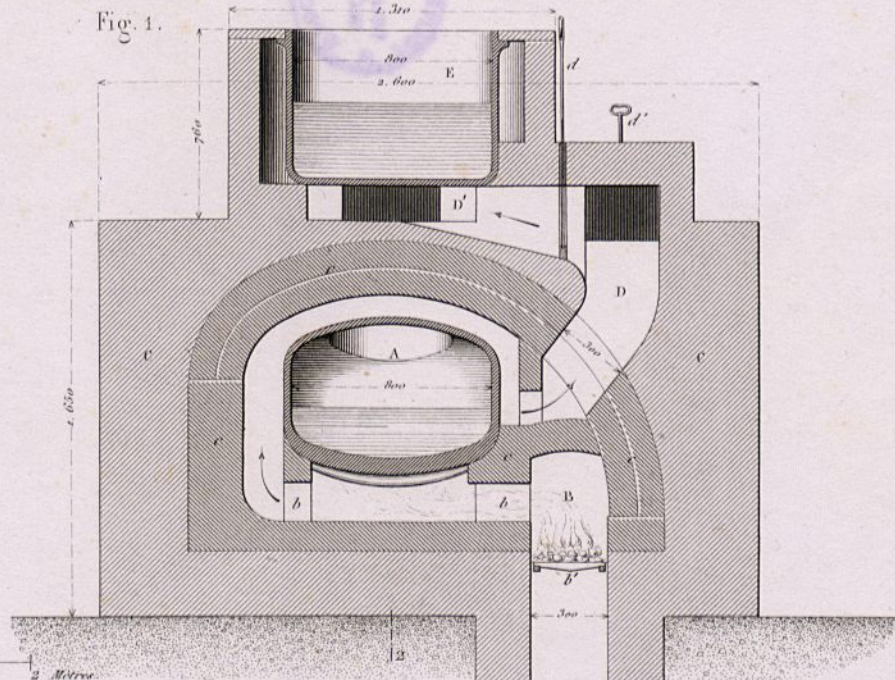
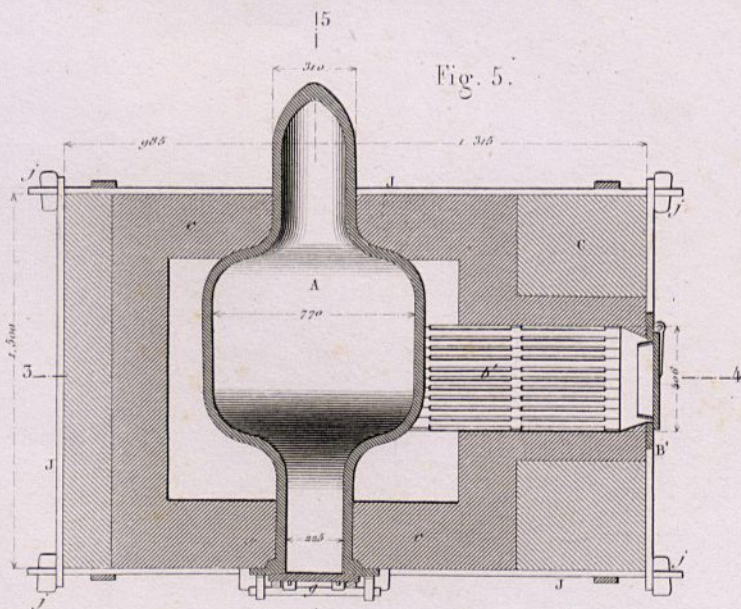

Echelle de 1/30 pour les Fig. 1 à 5.

0 1 2 3 4 5 6 7 8 9 10

2 Mètres

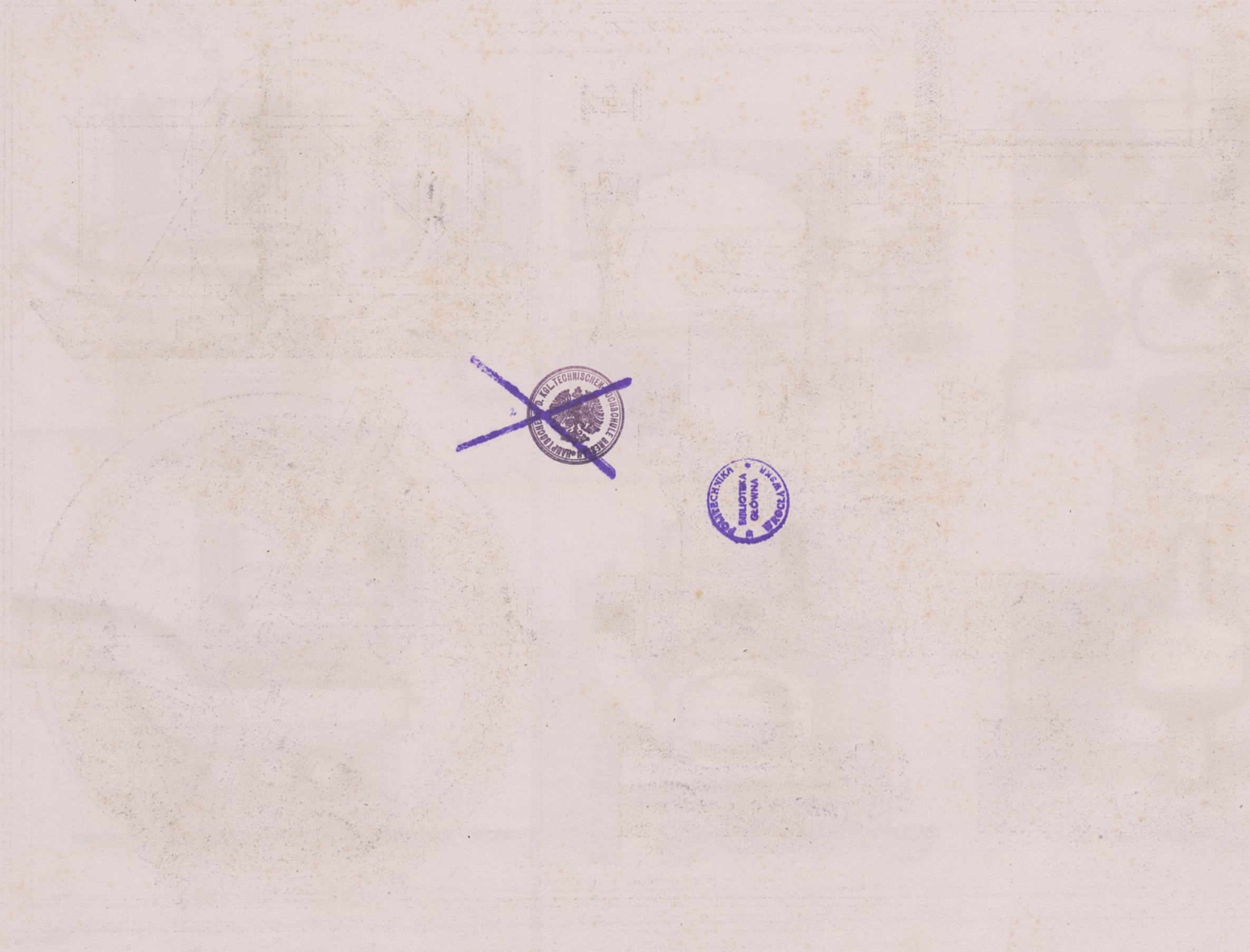

Appareil construit par la C^{ie} des établissements Cavié.

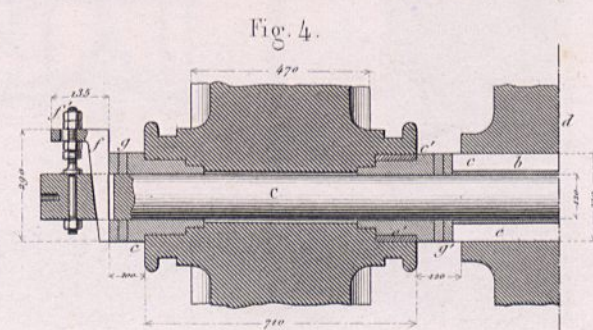
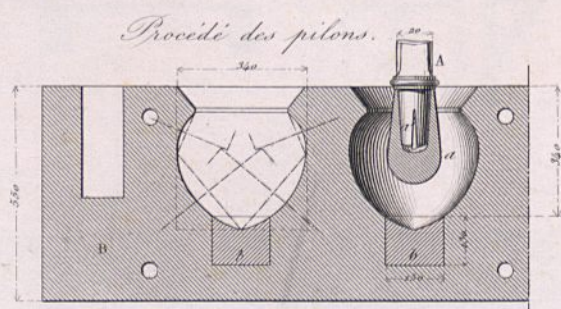
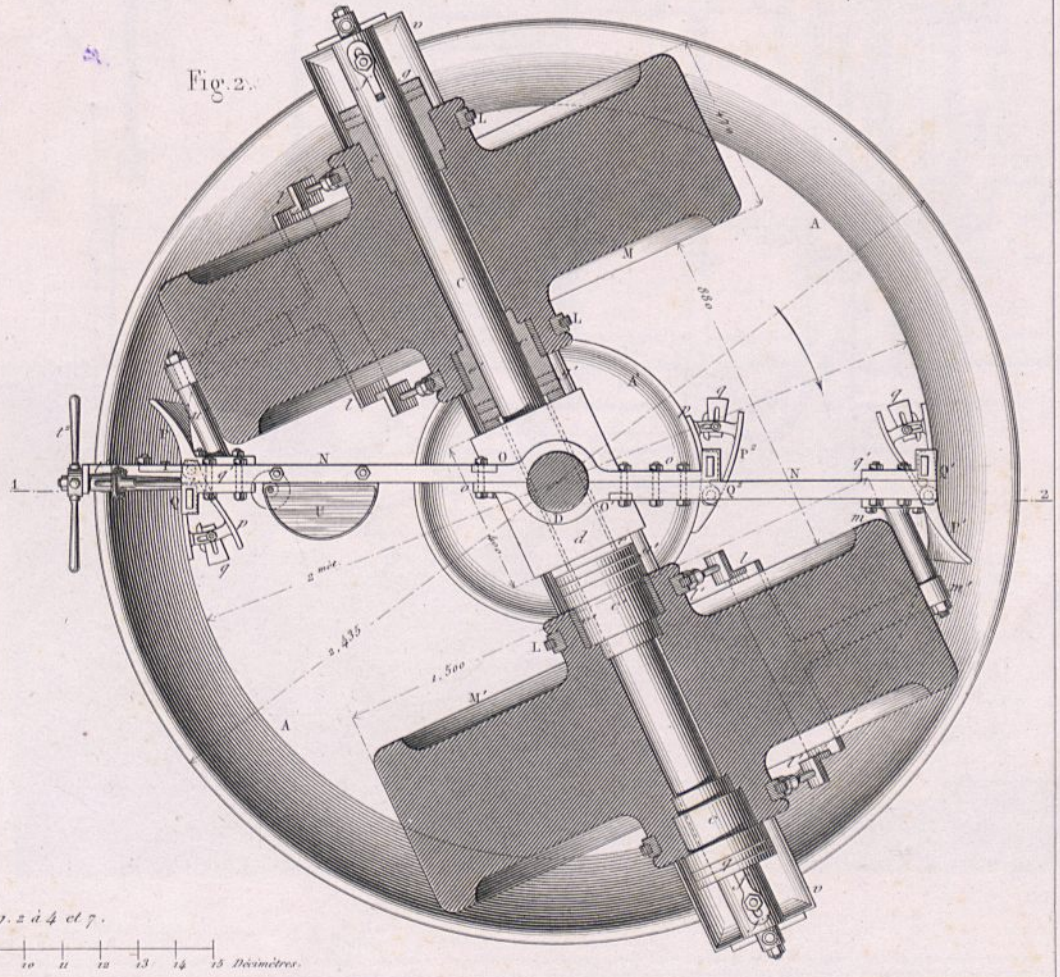
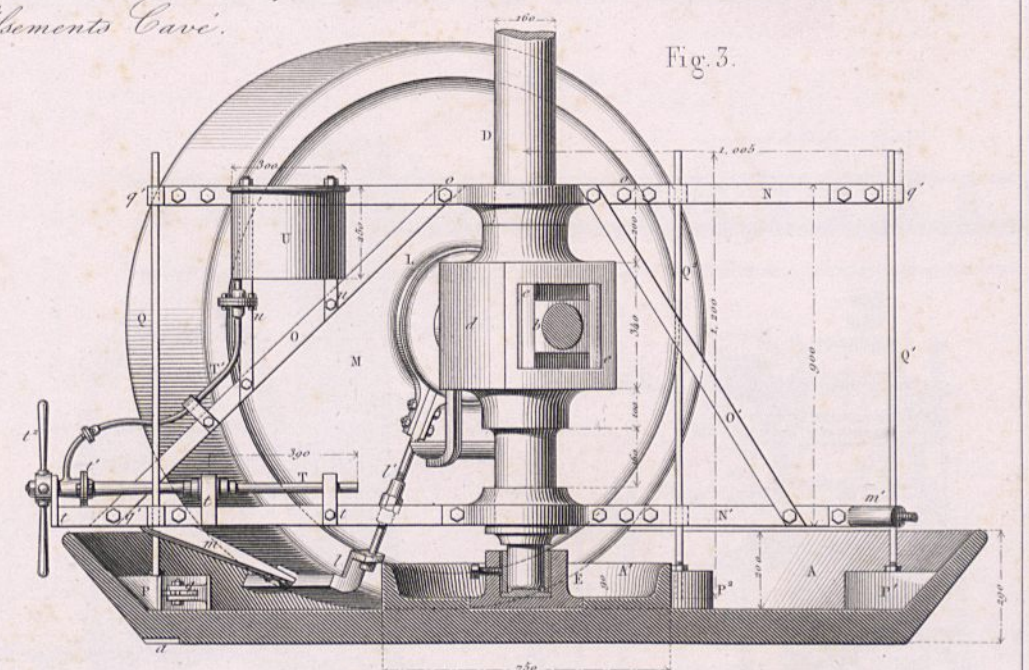
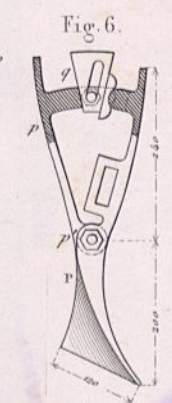
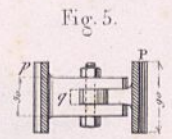
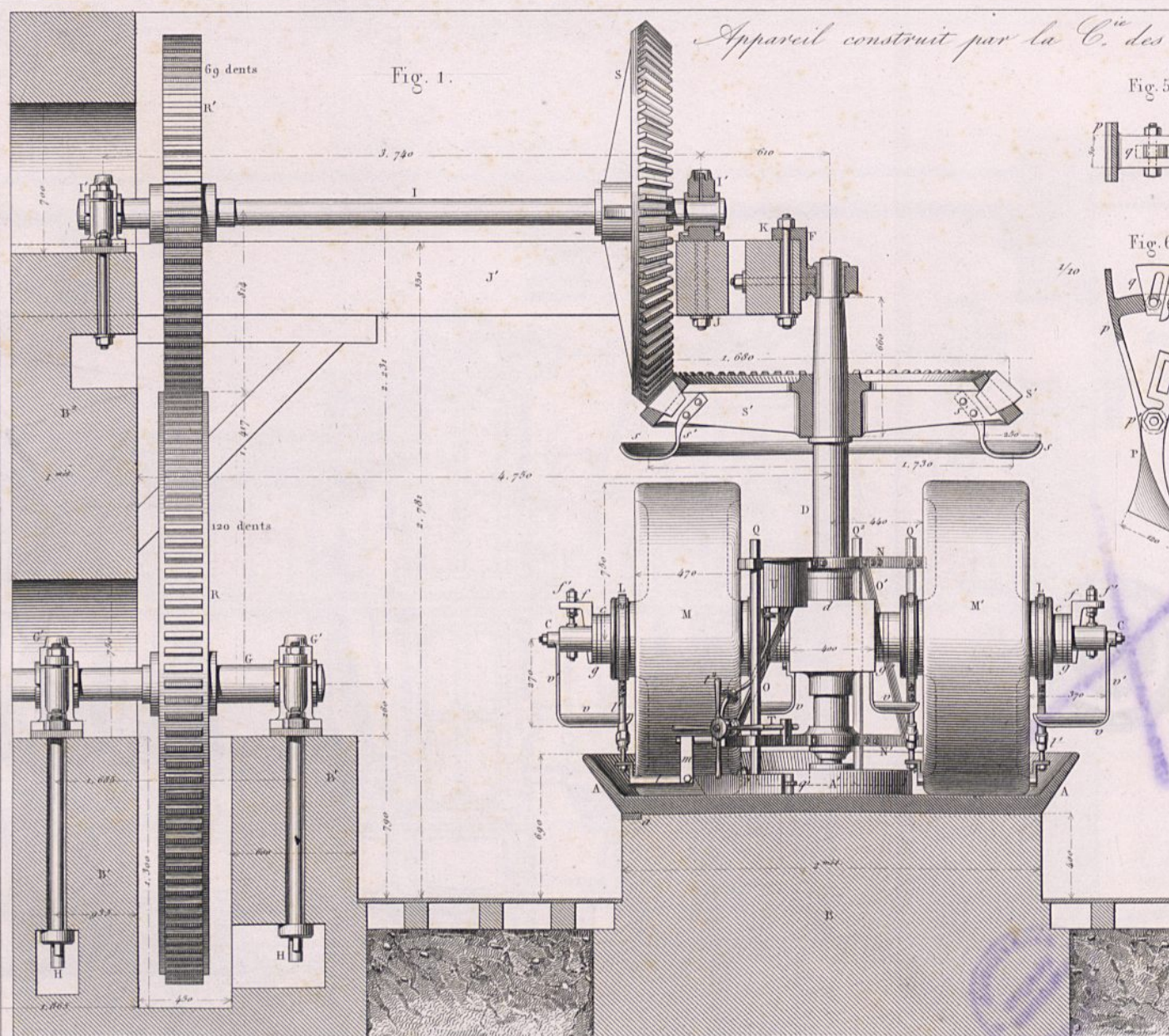

Echelle de 1/30 pour la Fig. 1.

Echelle de 1/20 pour les Fig. 2 à 4 et 7.

Div. 10 9 8 7 6 5 4 3 2 1 0

2 Mètres.

0 1 2 3 4 5 6 7 8 9 10 11 12 13 14 15 Décimètres.



Fig. 1.

Longueur de l'atelier = 25,655

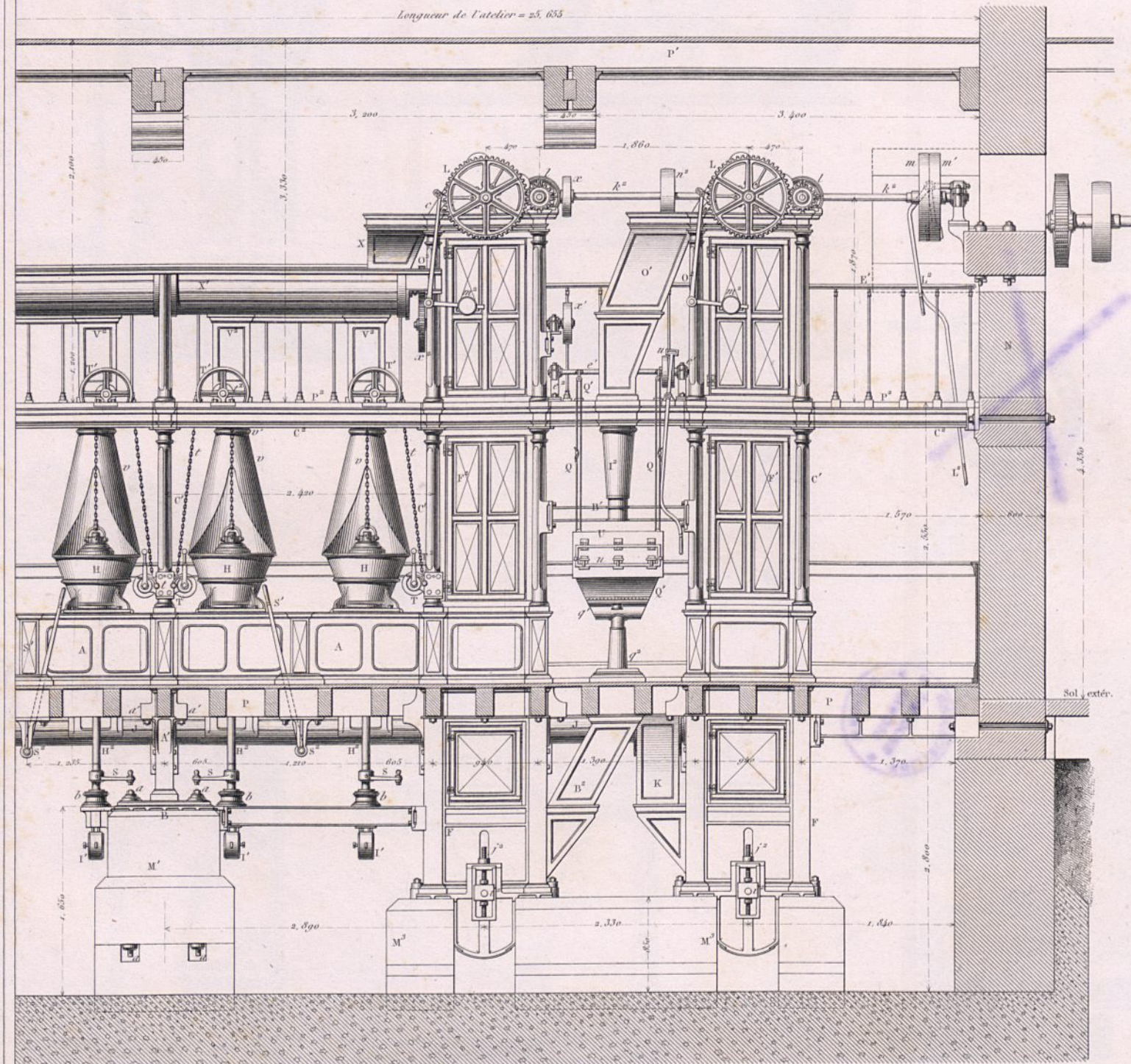
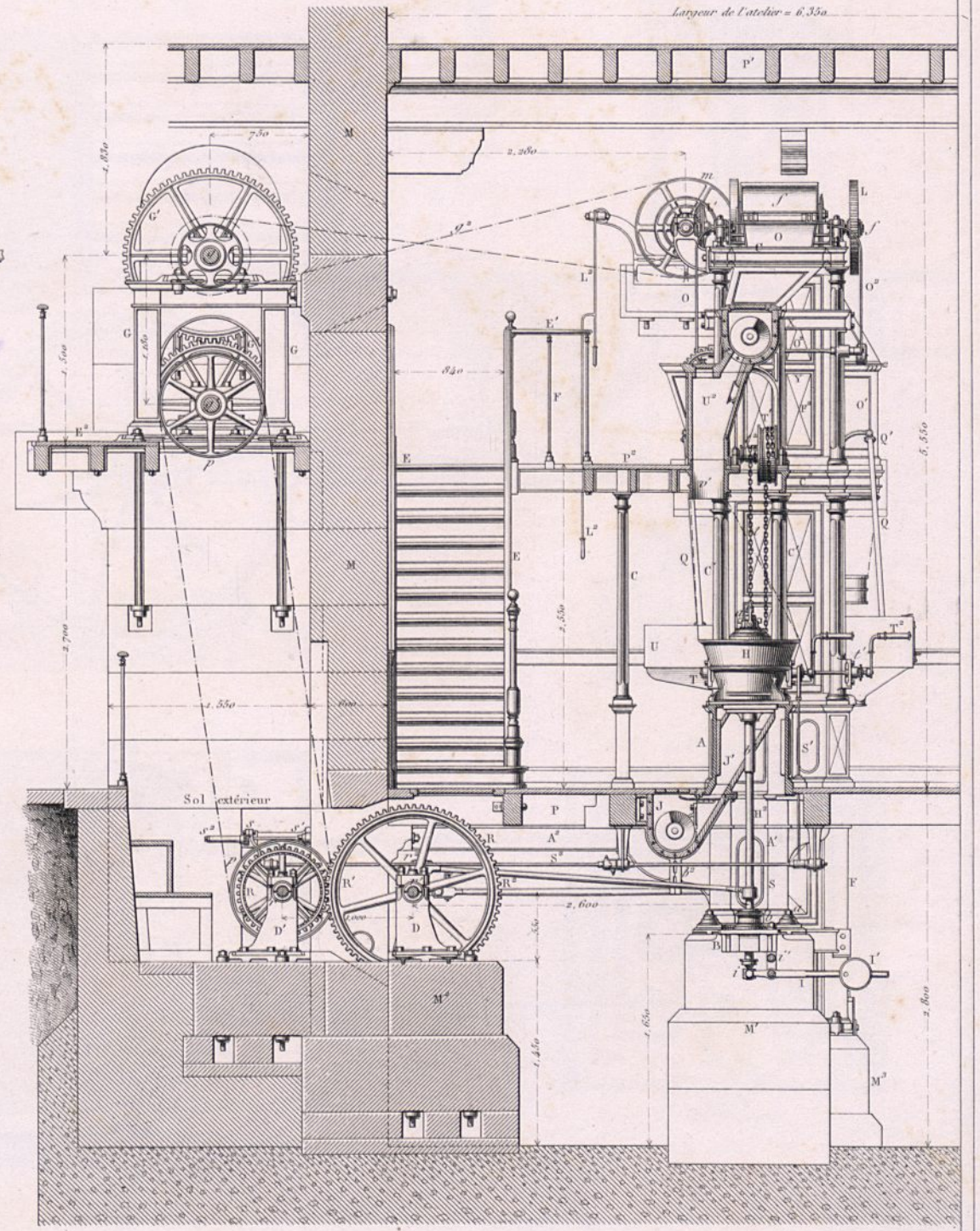

Fig. 2.

Largeur de l'atelier = 6,35a



Echelle de 1/50.

Déc. 10 9 8 7 6 5 4 3 2 1 0

6 Mètres.



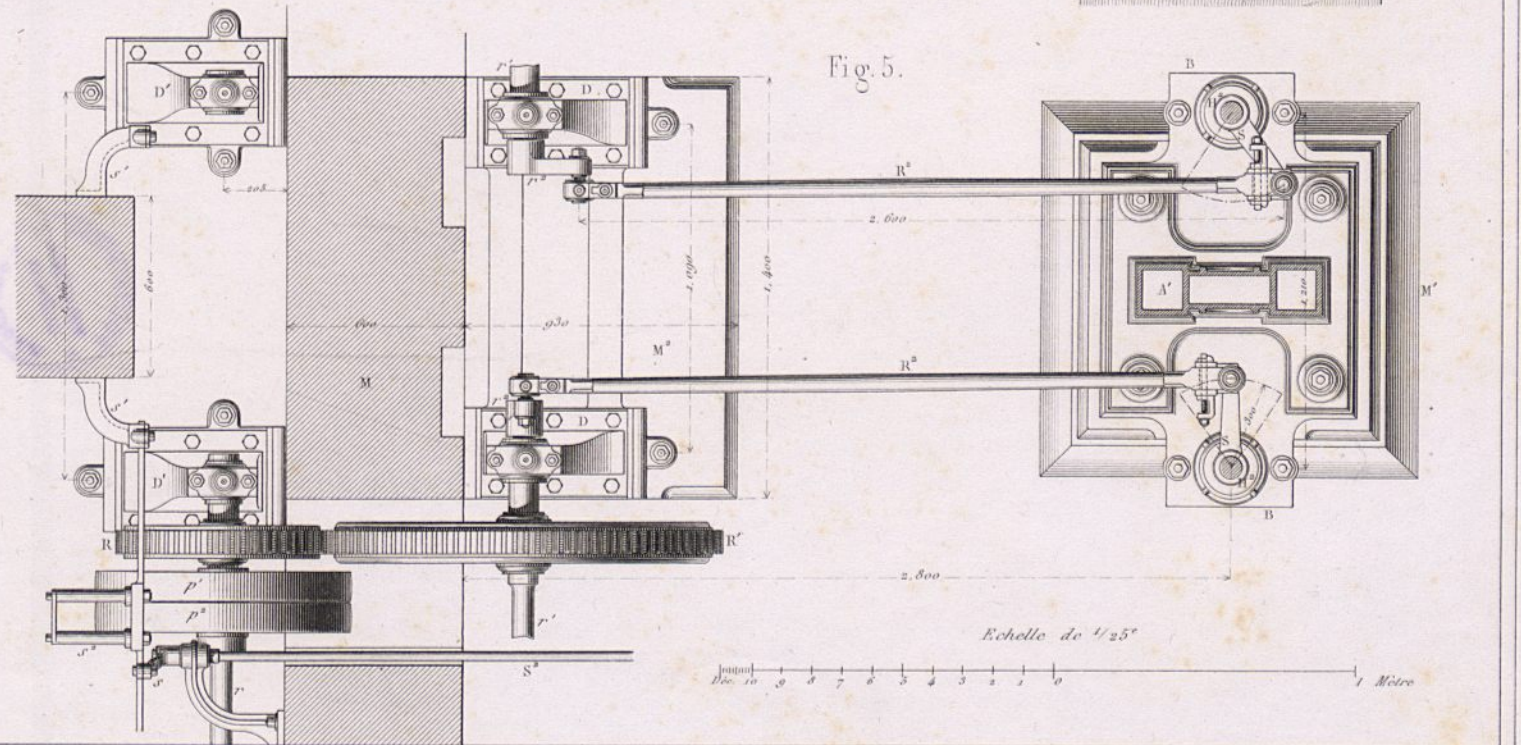
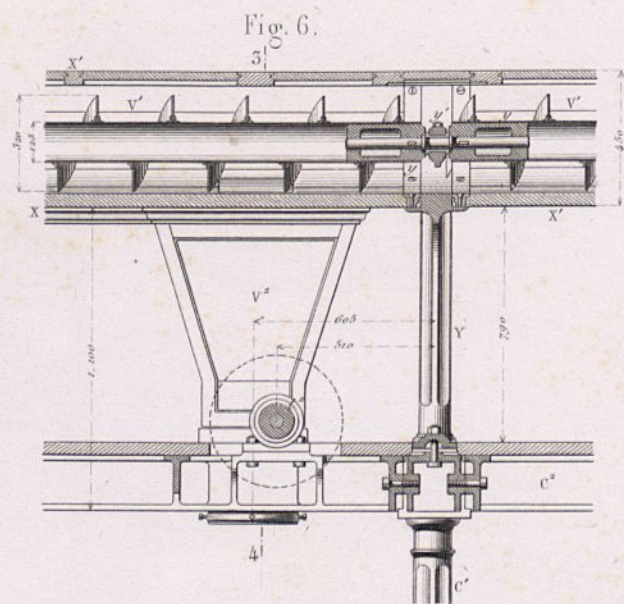
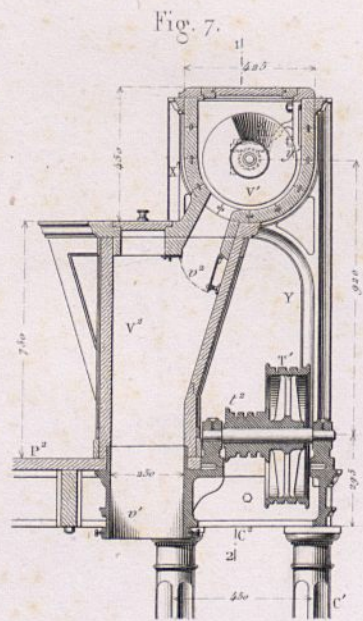
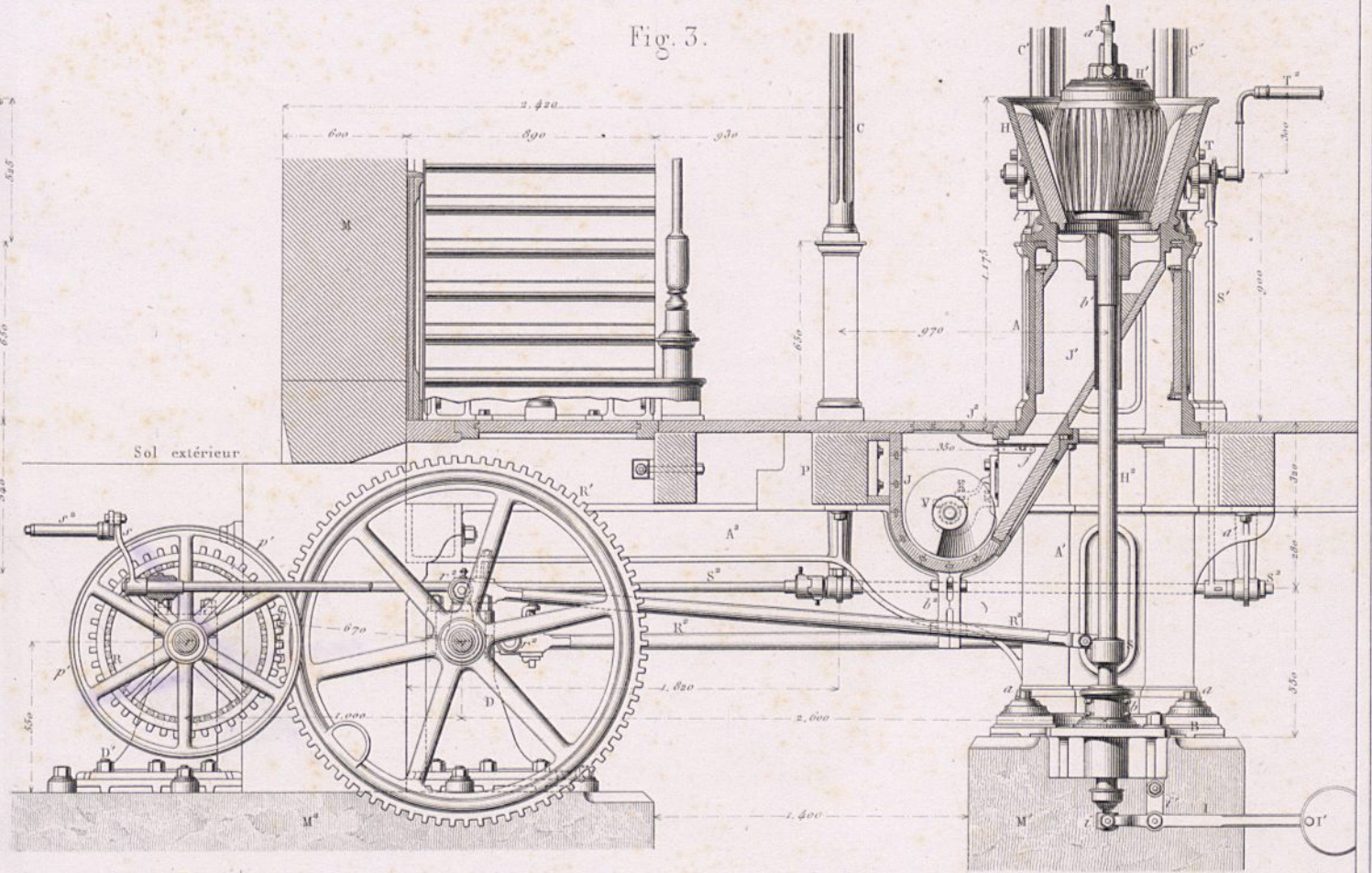
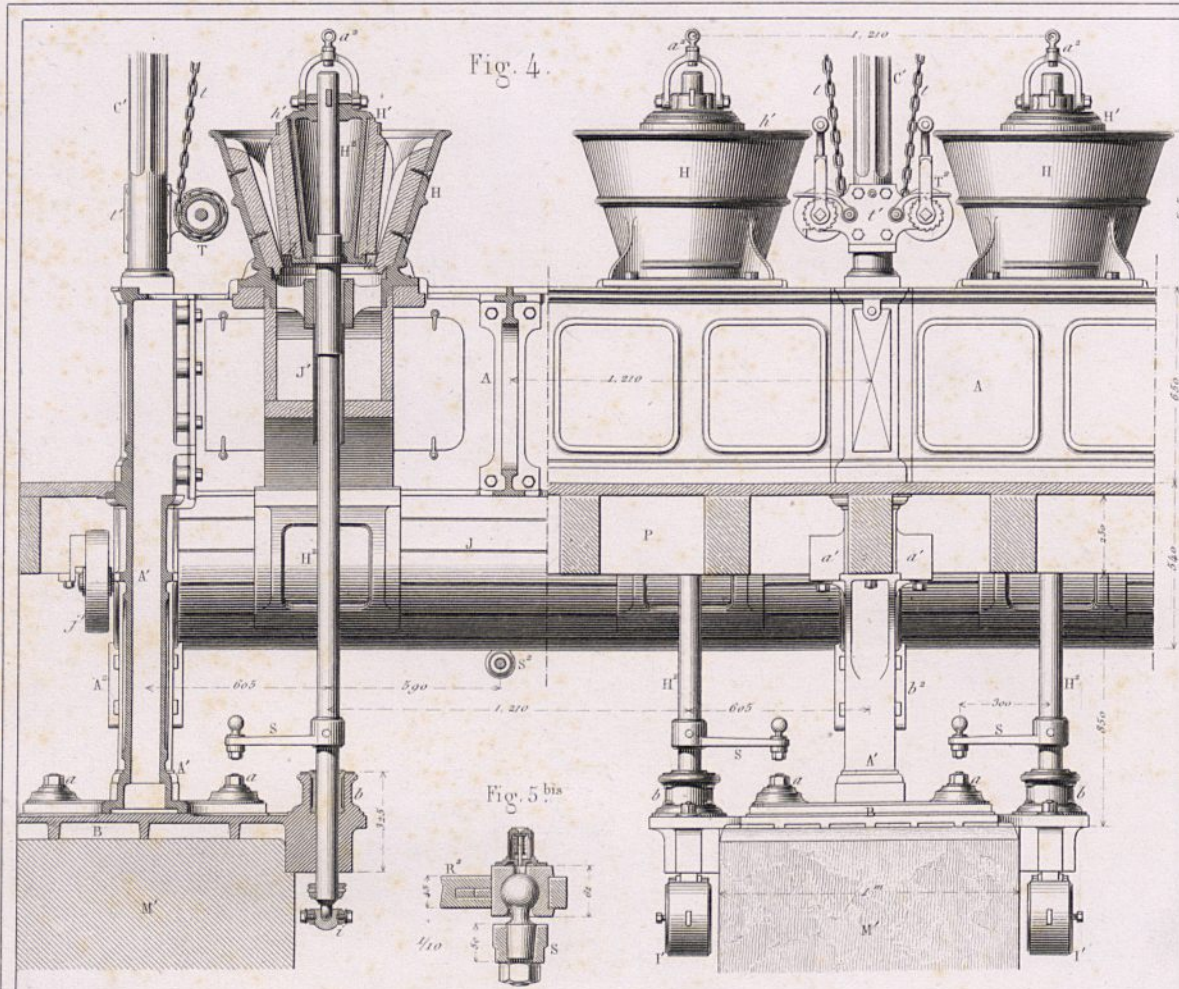



Fig. 8.

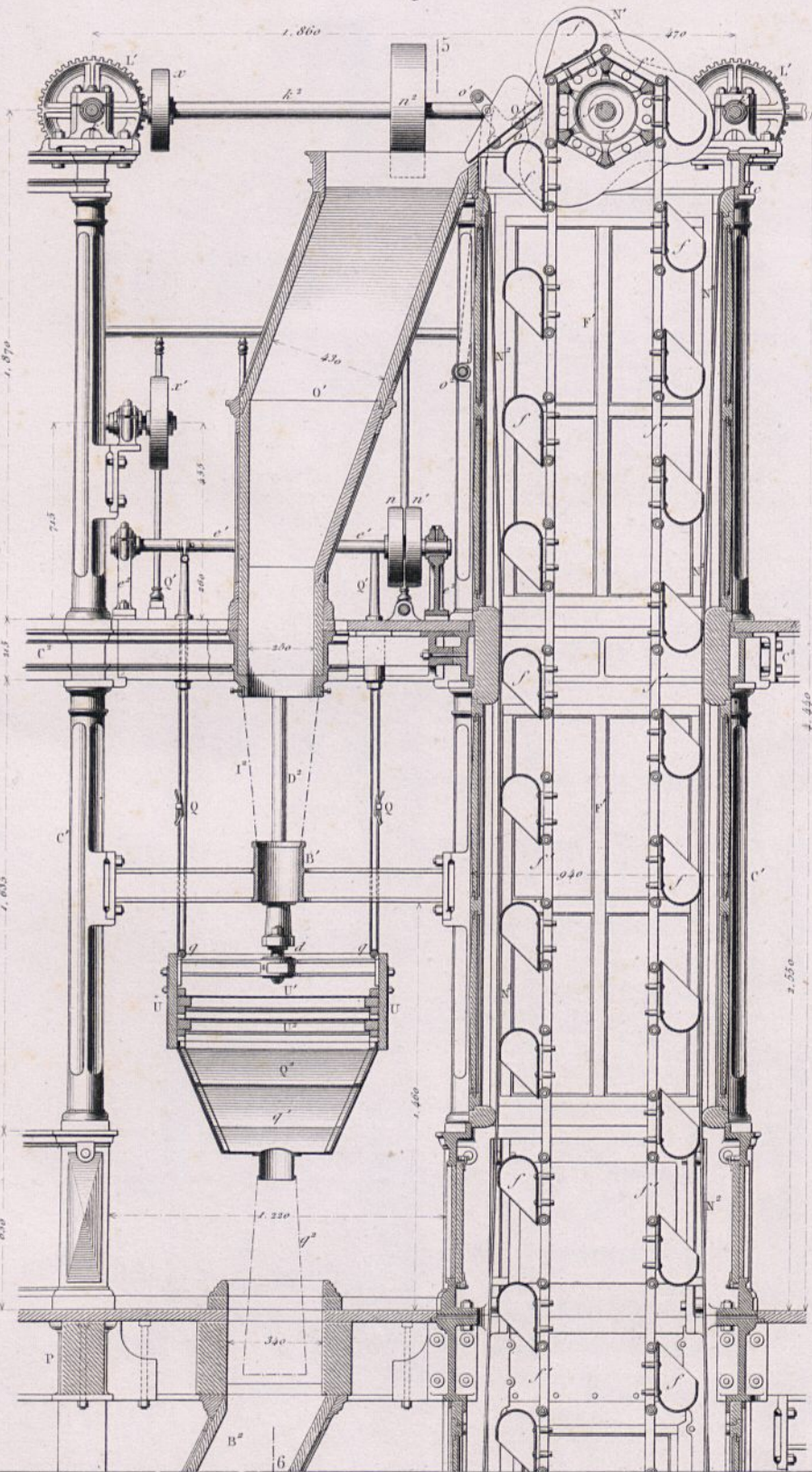

Fig. 10.

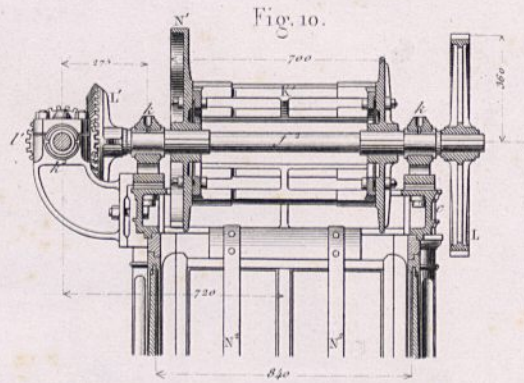

Fig. 14.



Fig. 12.

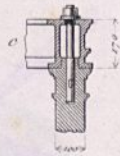

Fig. 13.

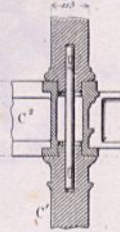
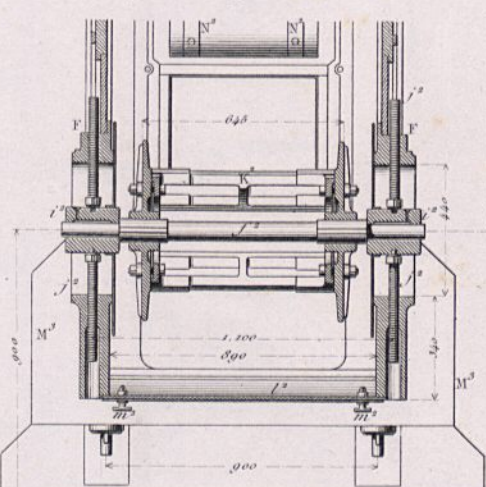

Fig. 15.



Fig. 11.



Echelle de 1/25^e

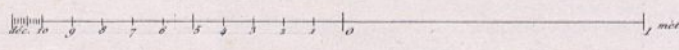
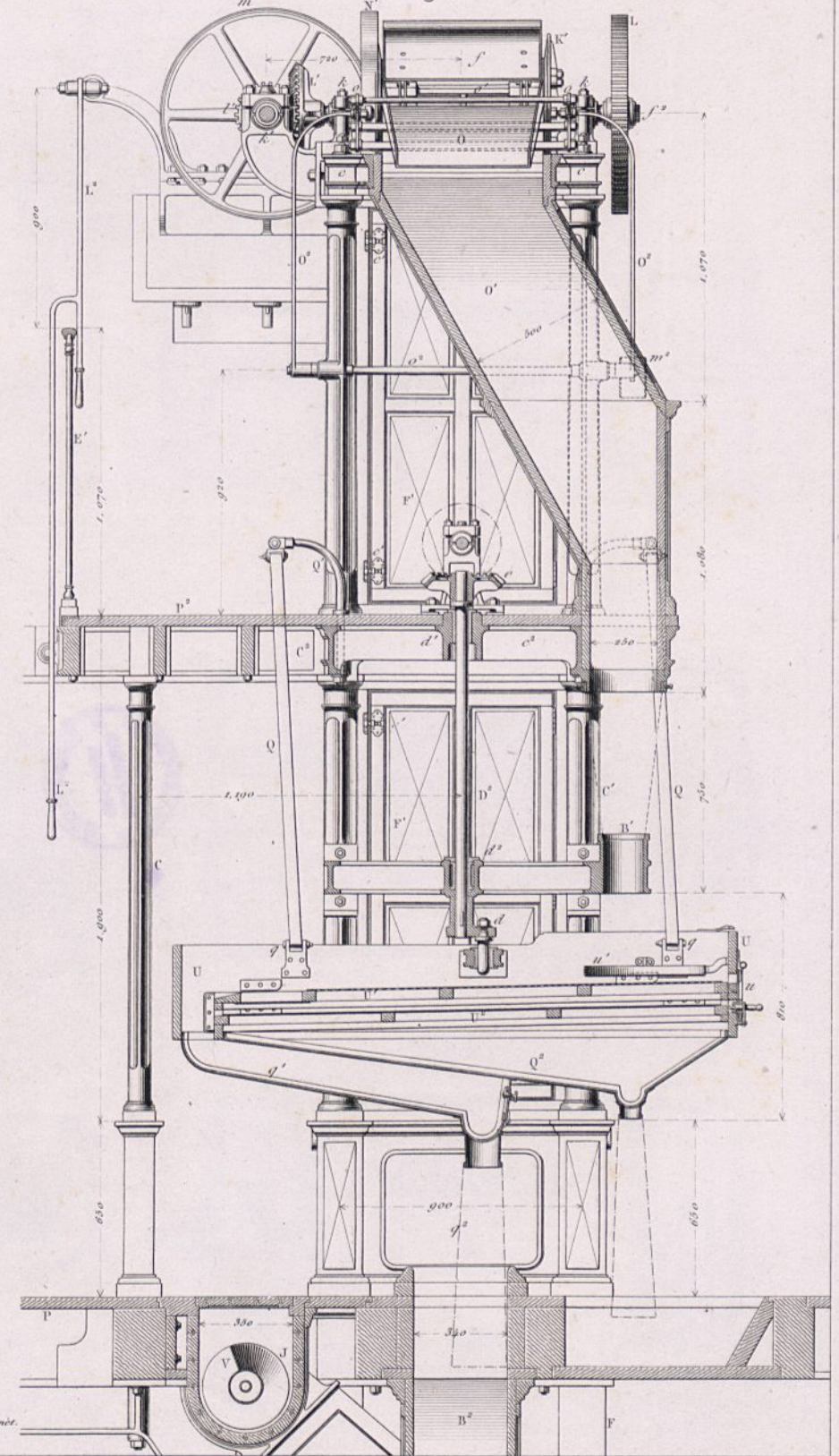

Fig. 9.





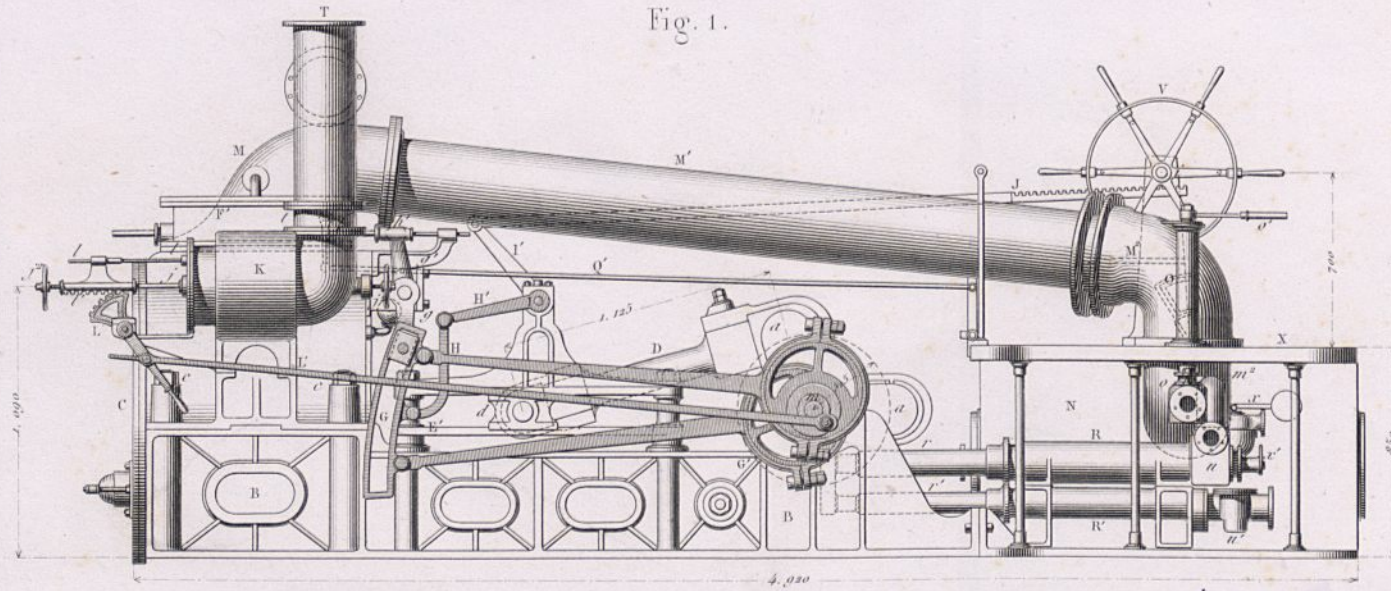

Fig. 1.

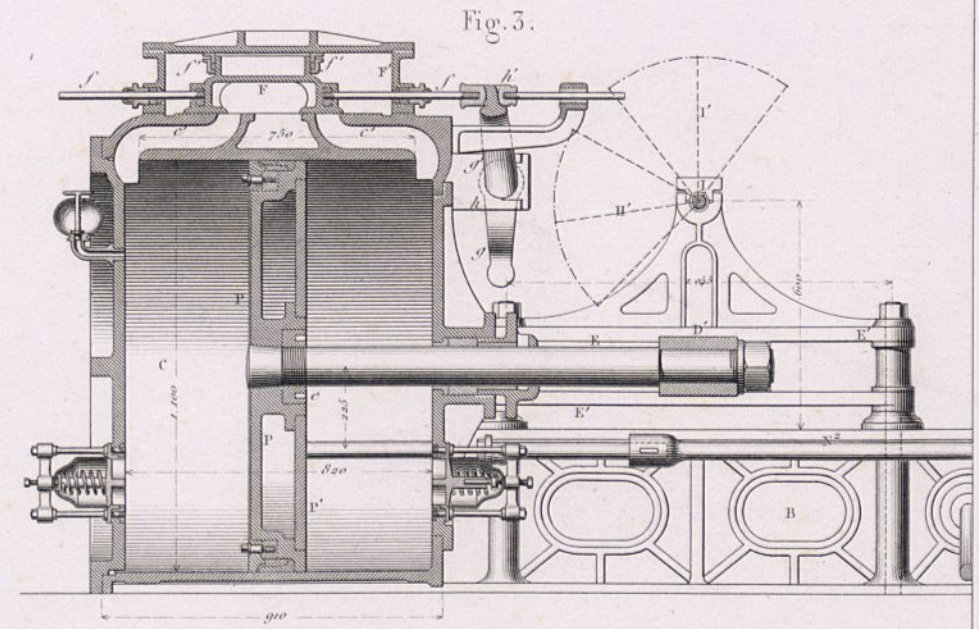

Fig. 3.

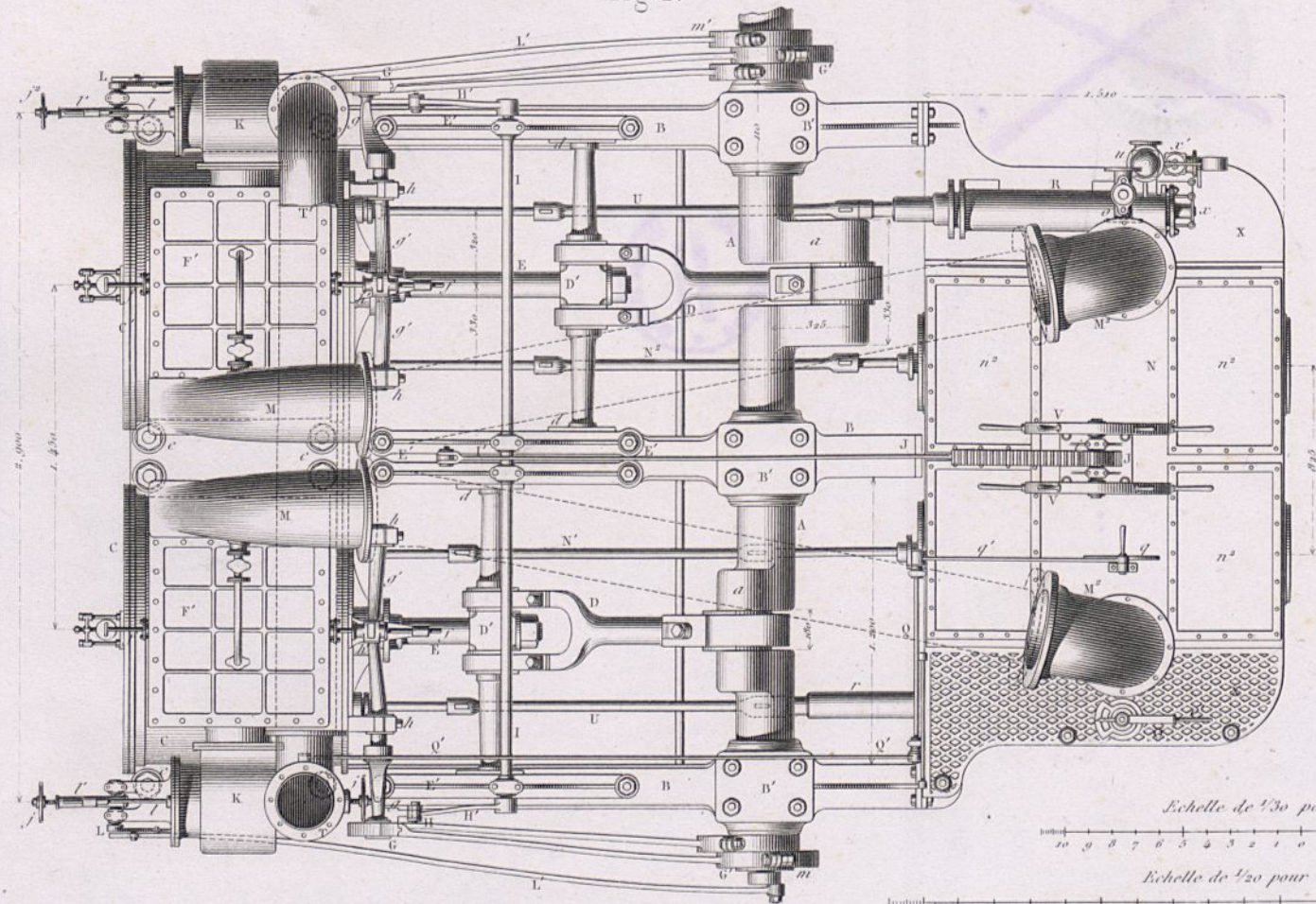

Fig. 2.

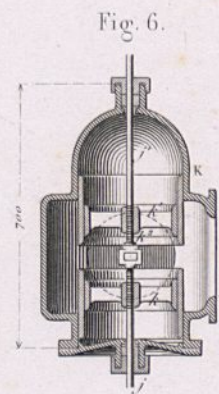

Fig. 6.

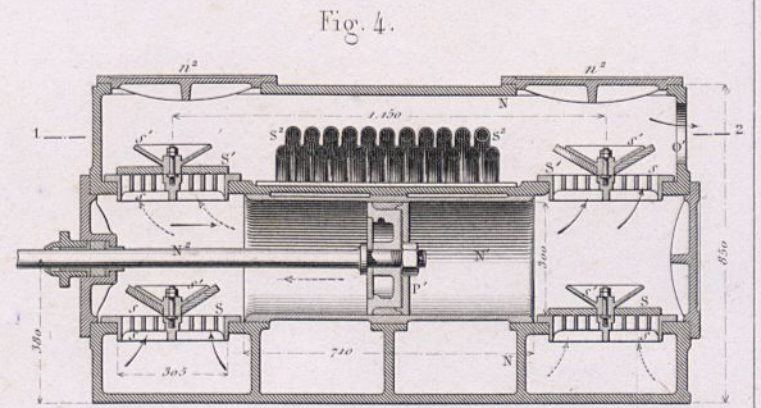

Fig. 4.

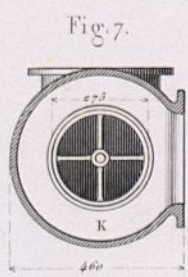

Fig. 7.

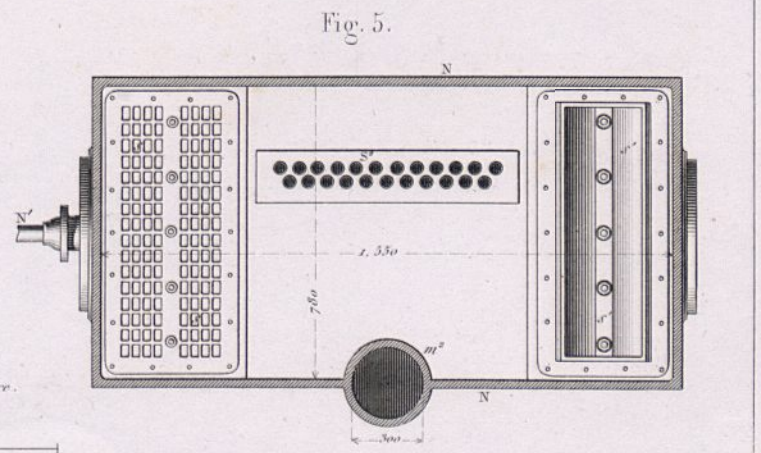
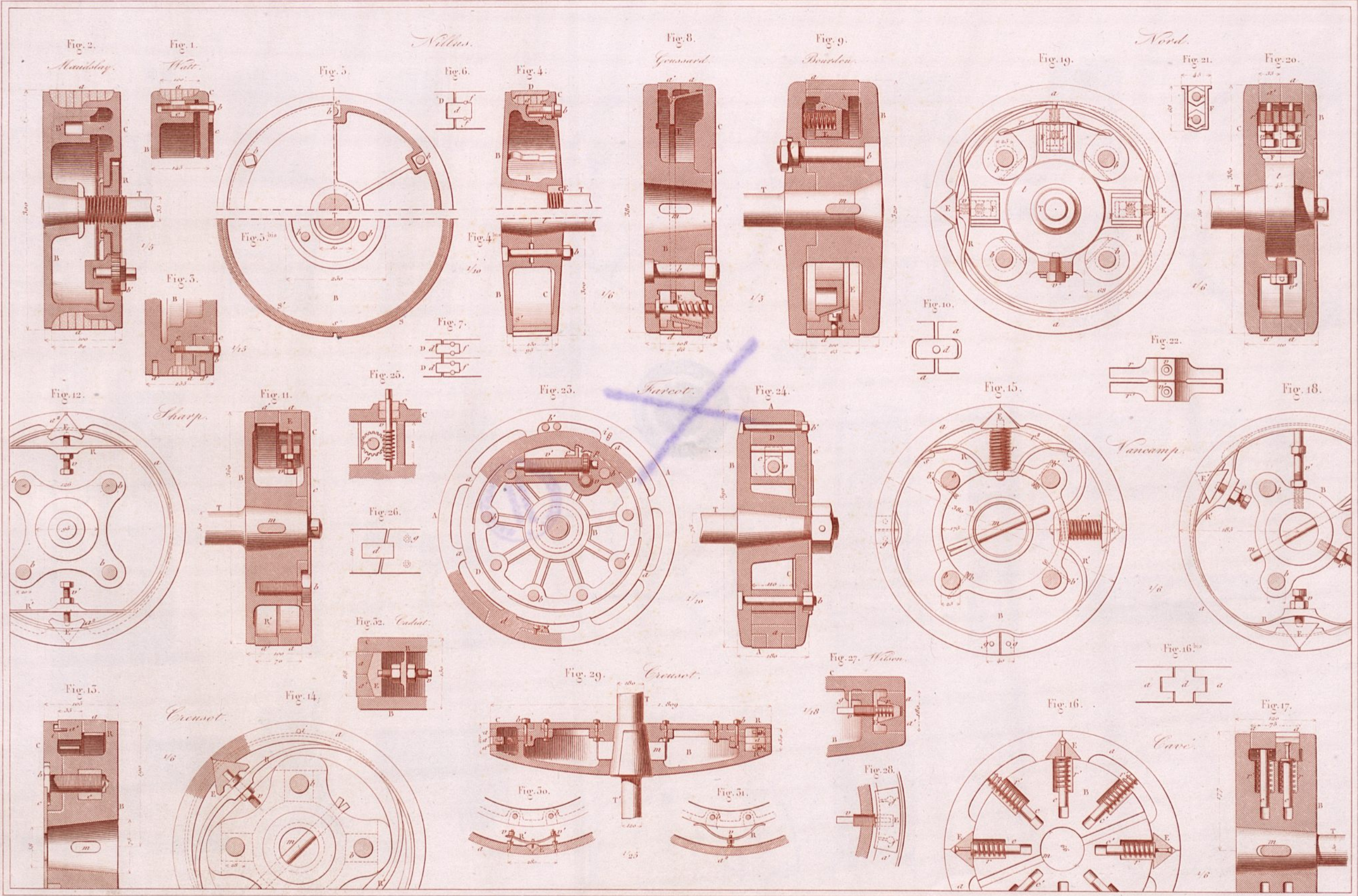

Fig. 5.

Echelle de 1/30 pour les Fig. 1 et 2
 10 9 8 7 6 5 4 3 2 1 0 1 Mètre.

Echelle de 1/20 pour les Fig. 3 à 7.
 10 9 8 7 6 5 4 3 2 1 0 1 Mètre.







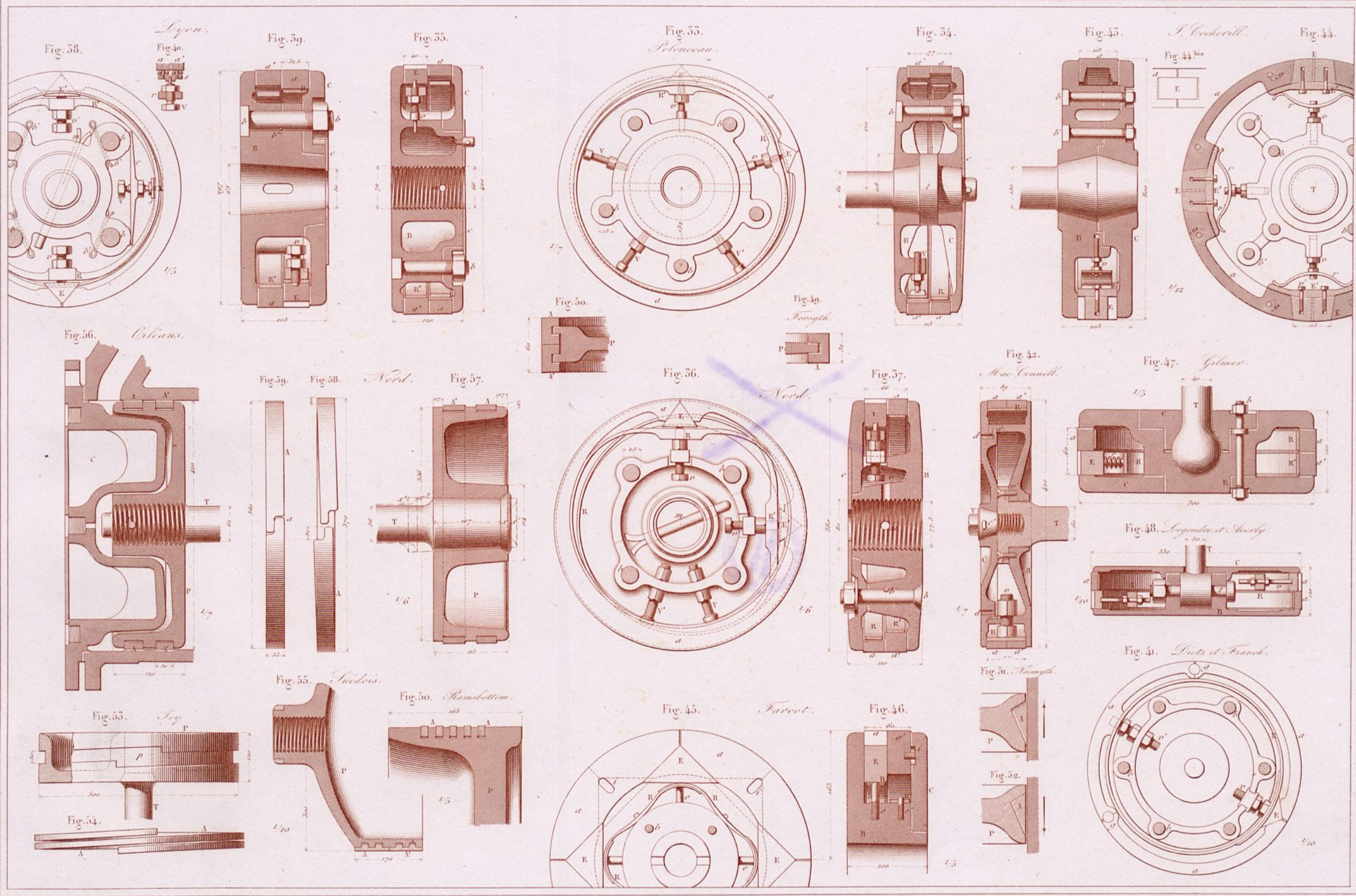



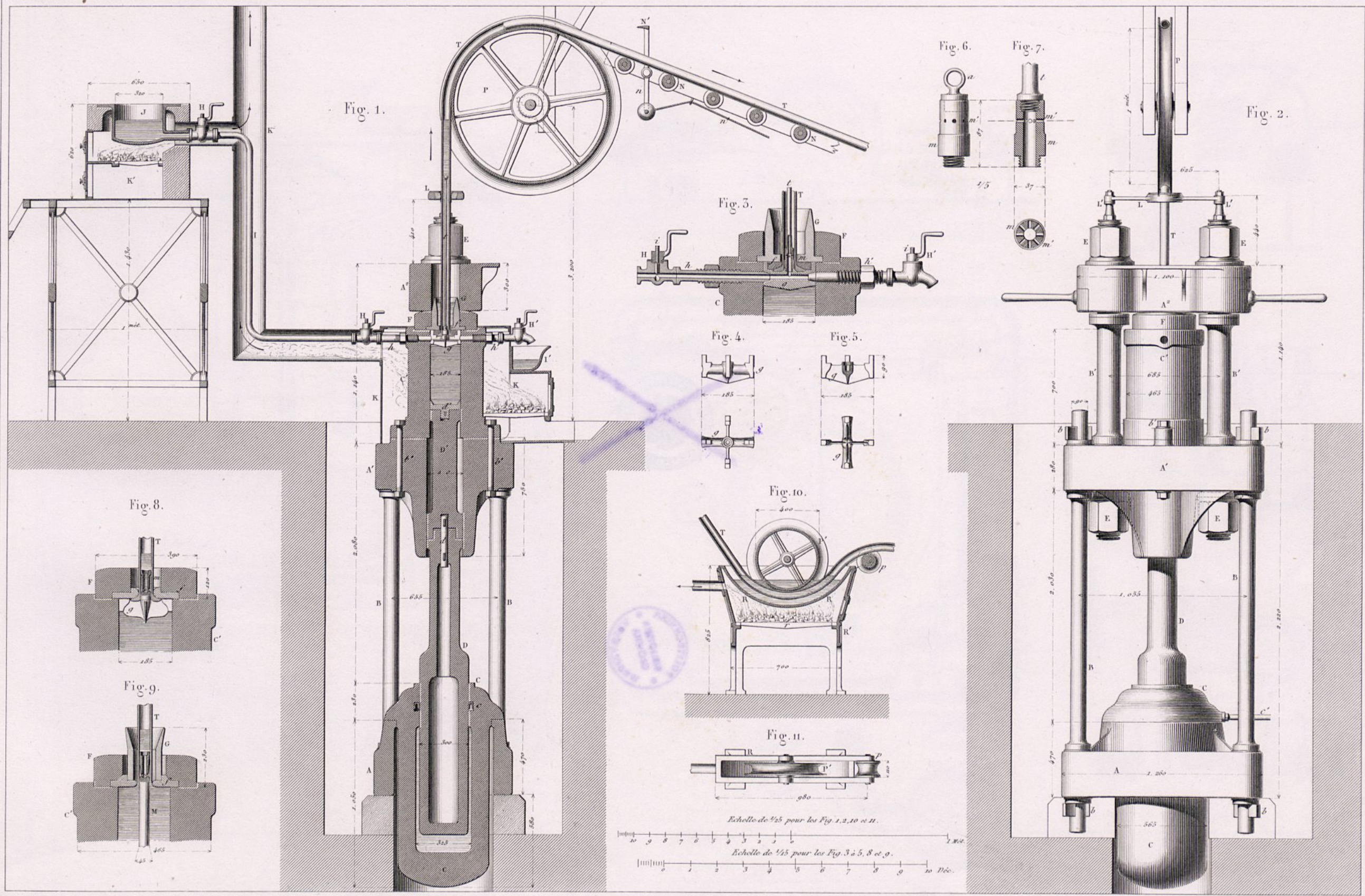



Fig. 1.

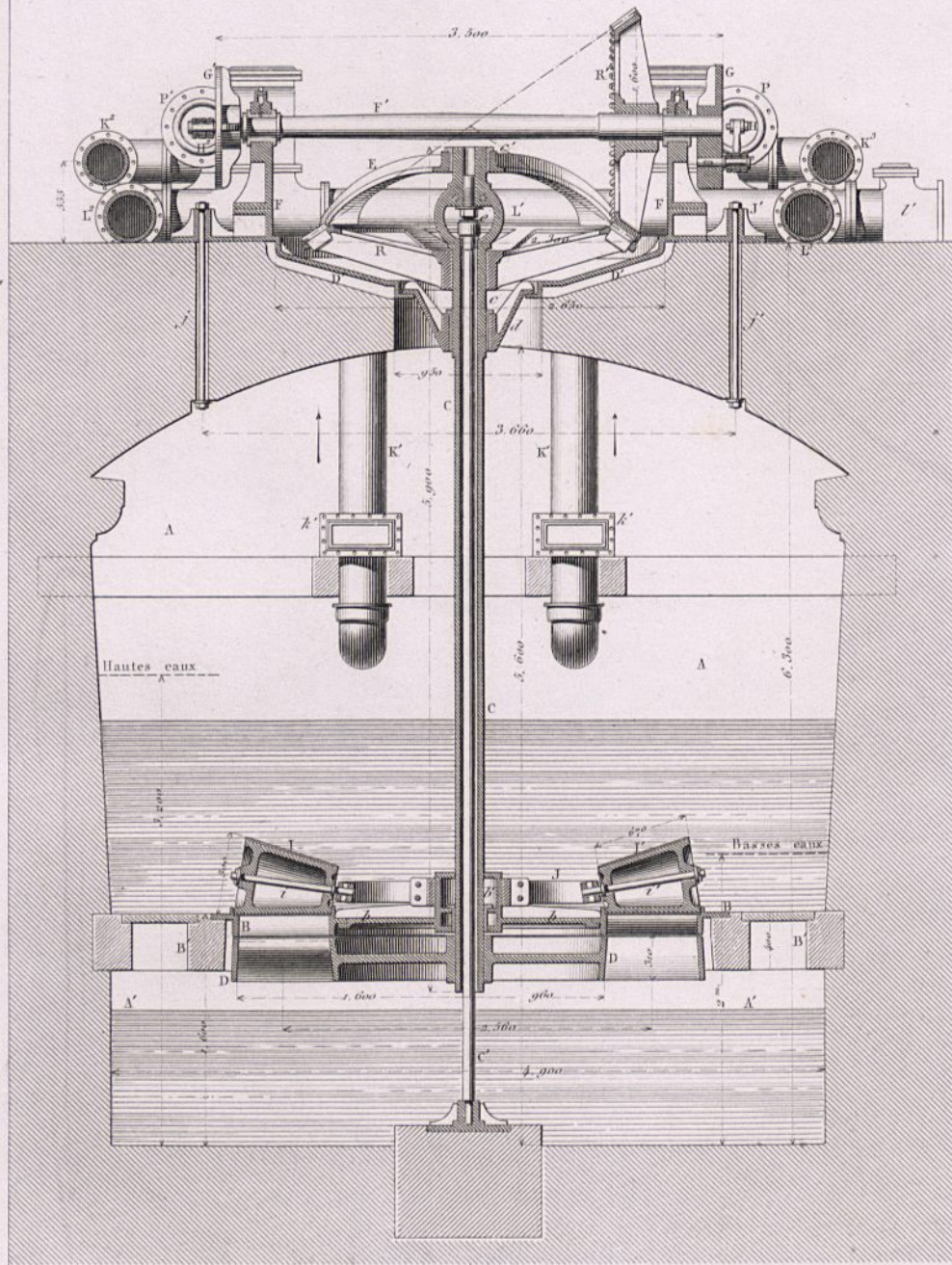

Fig. 3.

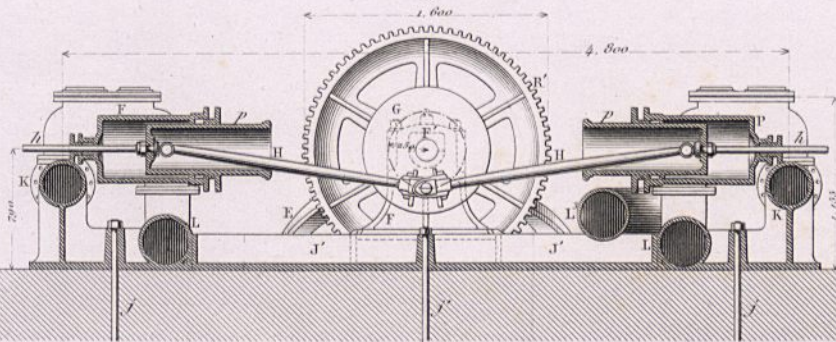

Fig. 2.

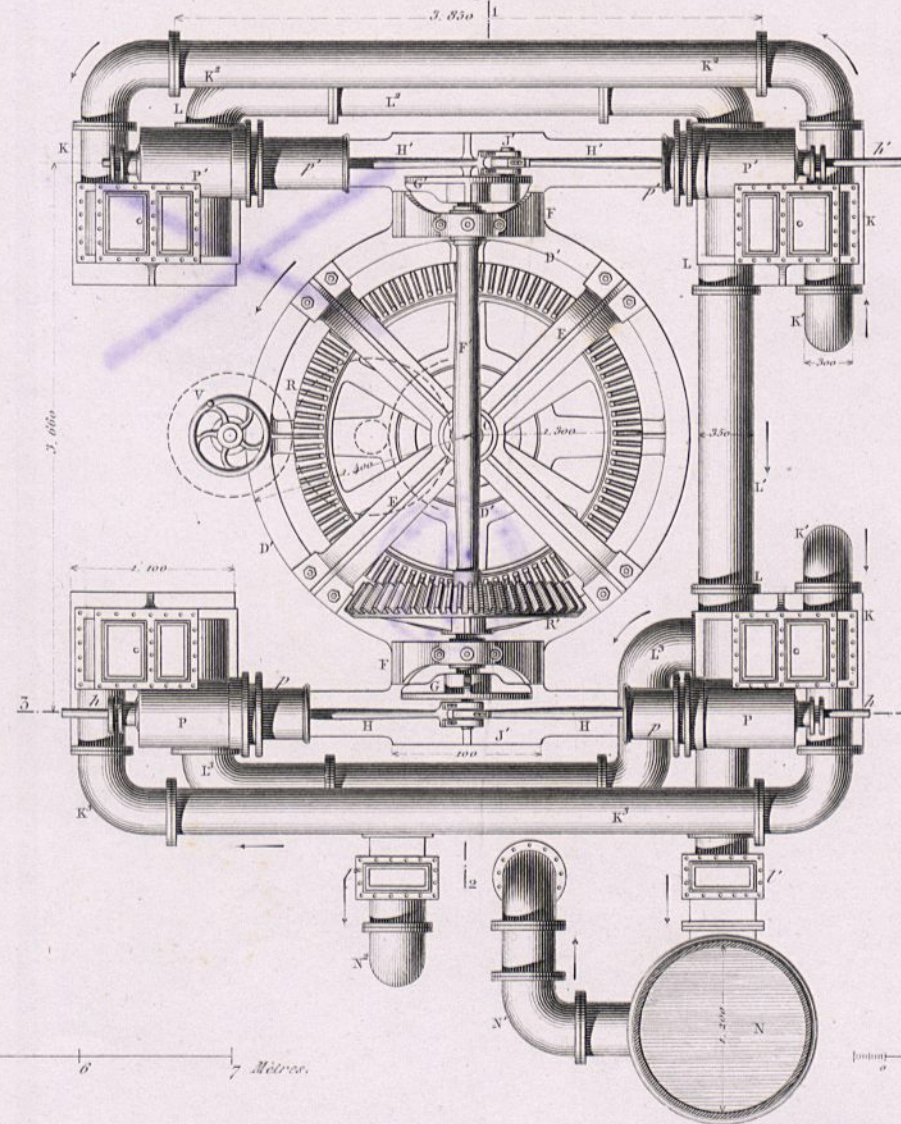

Fig. 4.

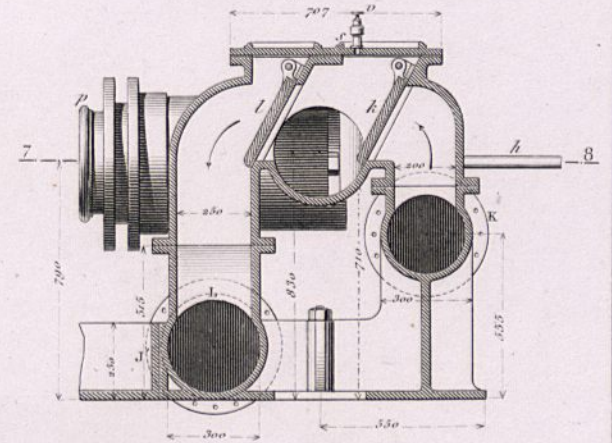

Fig. 5.

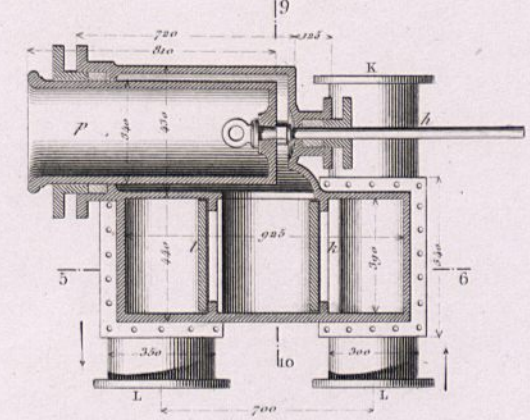

Fig. 7.

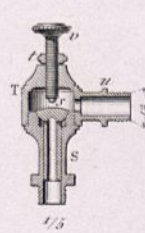
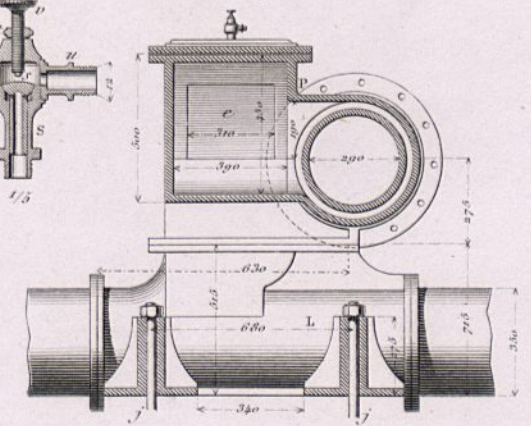
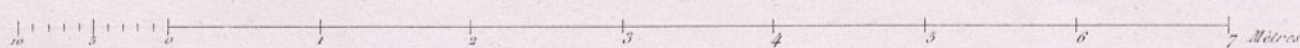

Fig. 6.



Echelle de 1/30 pour Fig. 1, 2 et 3.



Echelle de 1/25 pour Fig. 4 à 6.

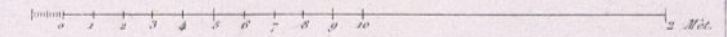



Récepteur.

Relais.

Fig. 1.

Fig. 7.

Fig. 3.

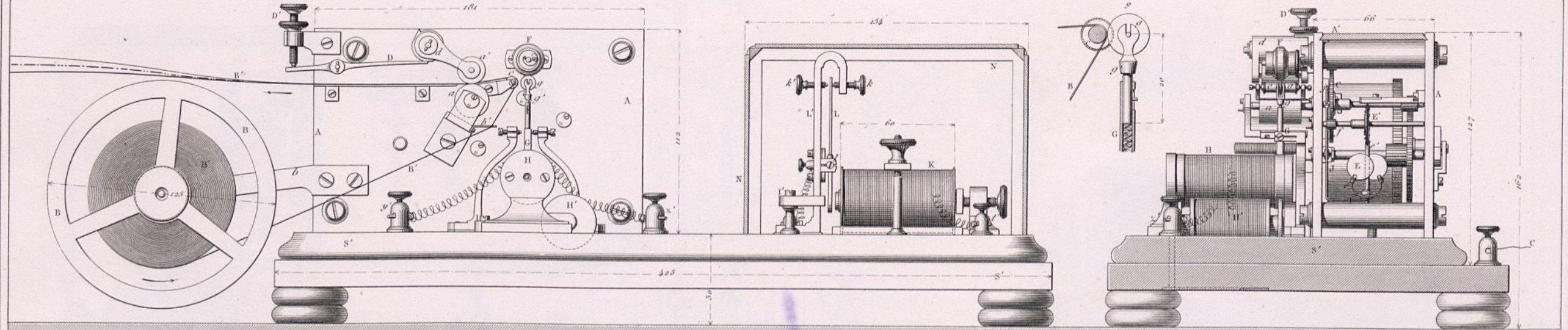

Fig. 5.

Fig. 2.

Fig. 4.

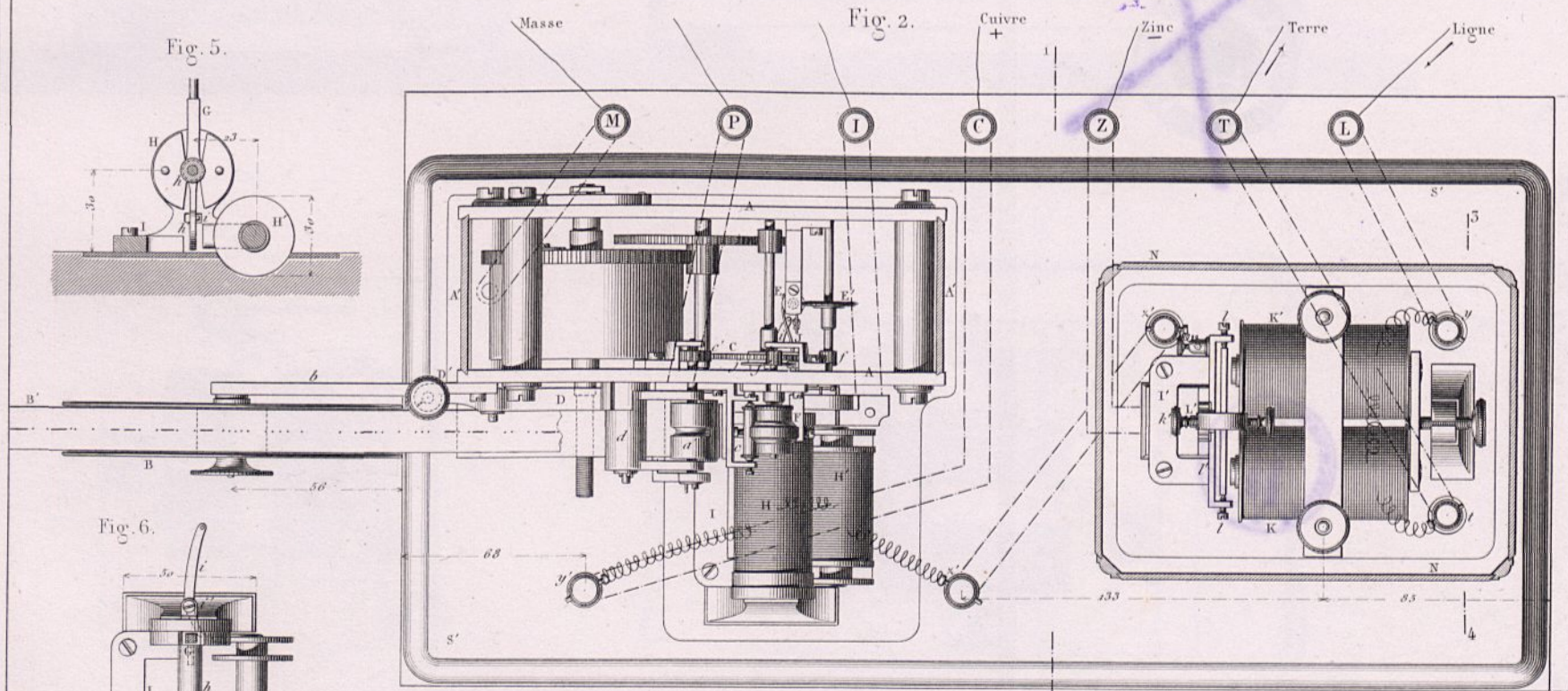

Fig. 8.

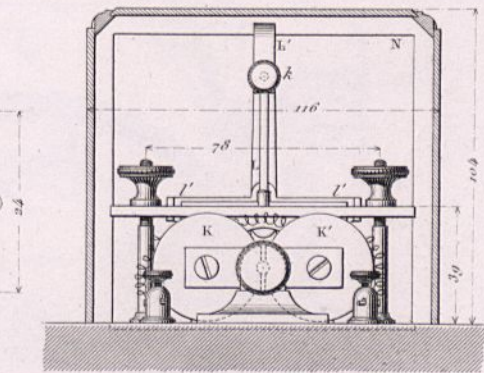
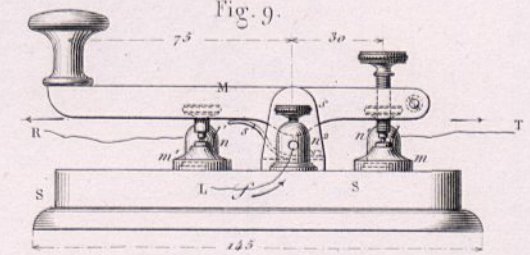
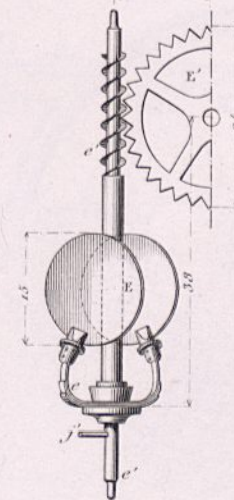
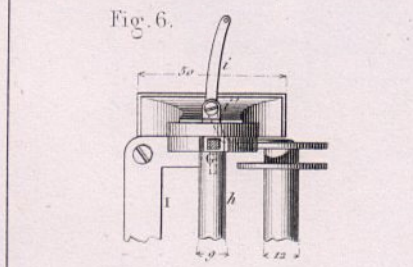

Fig. 6.

Manipulateur.

Fig. 9.



Echelle de 7/5 pour les Fig. 1 à 6 et 9.

Cent. 10 9 8 7 6 5 4 3 2 1 0 2 Décimètres.



Récepteur

Manipulateur

Fig. 6.

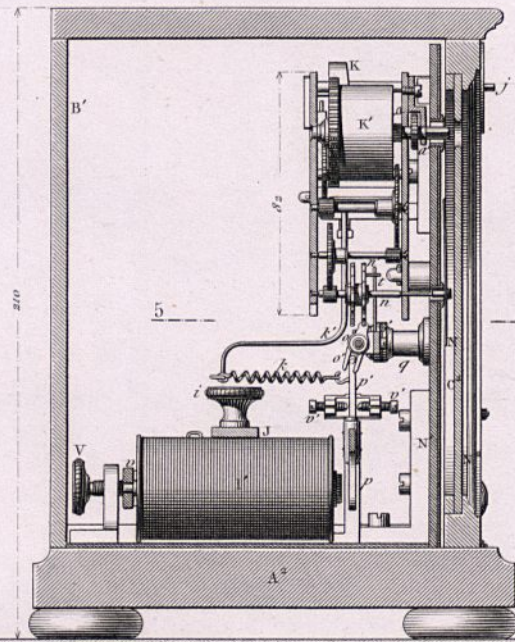

Fig. 8.

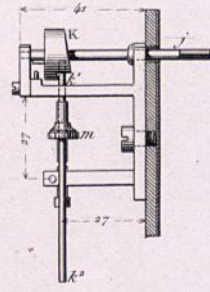

Fig. 4.

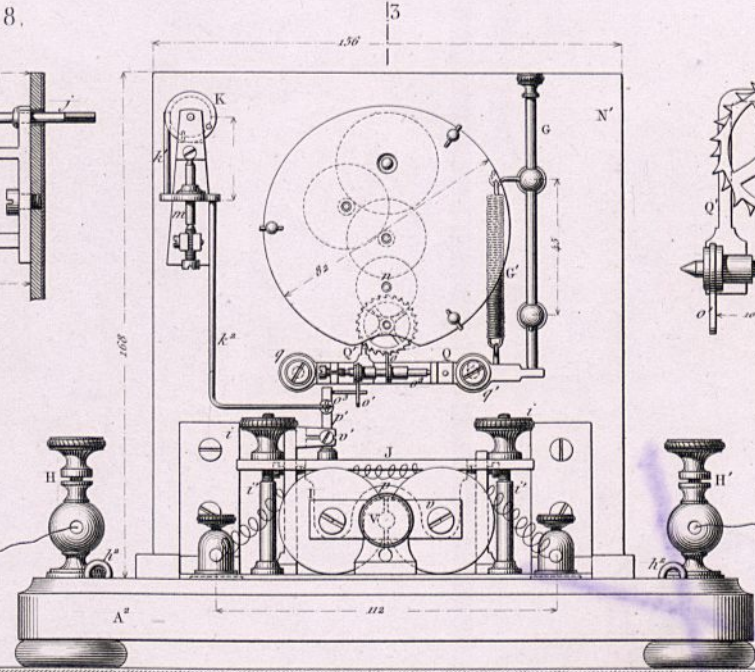

Fig. 9.

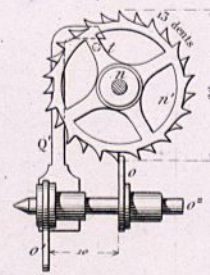

Fig. 10.

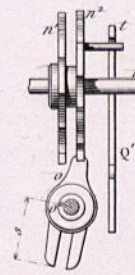

Fig. 3.

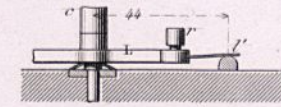

Fig. 2.

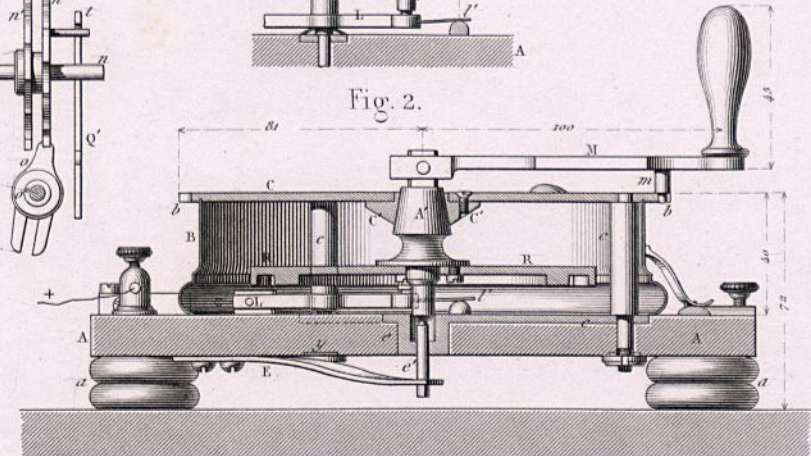

Fig. 7.

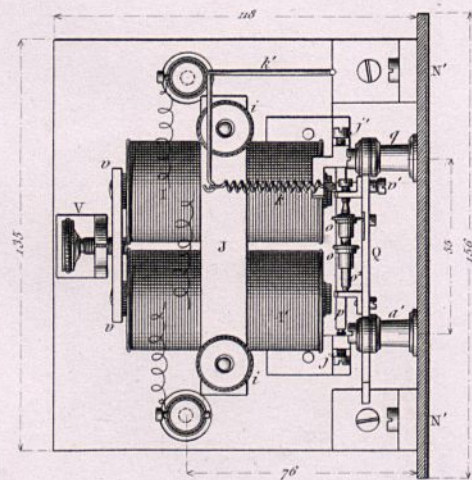

Fig. 5.

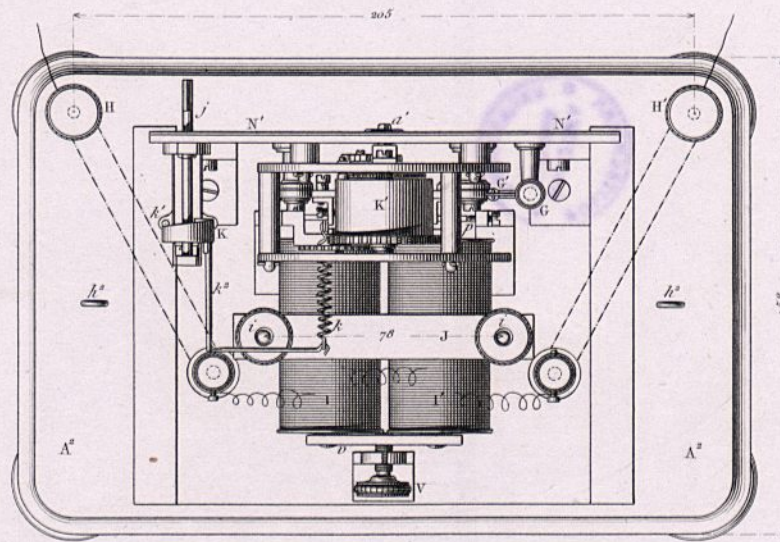
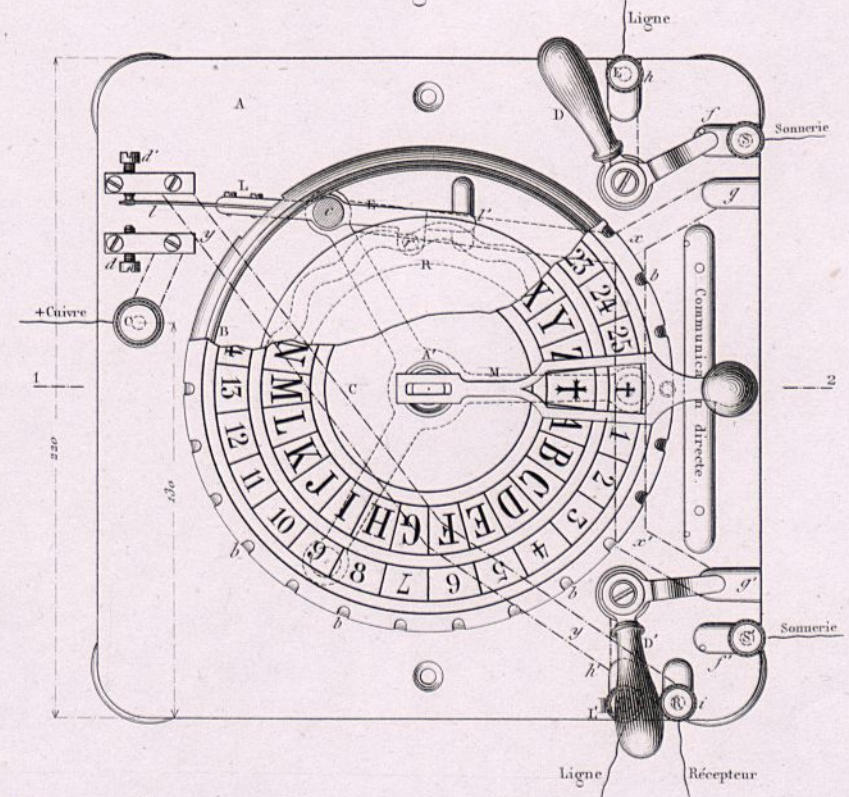
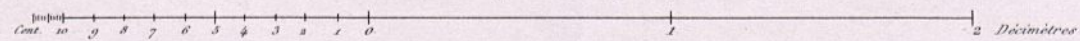

Fig. 1.



Echelle de 2/5 pour les Fig. 1 à 7.





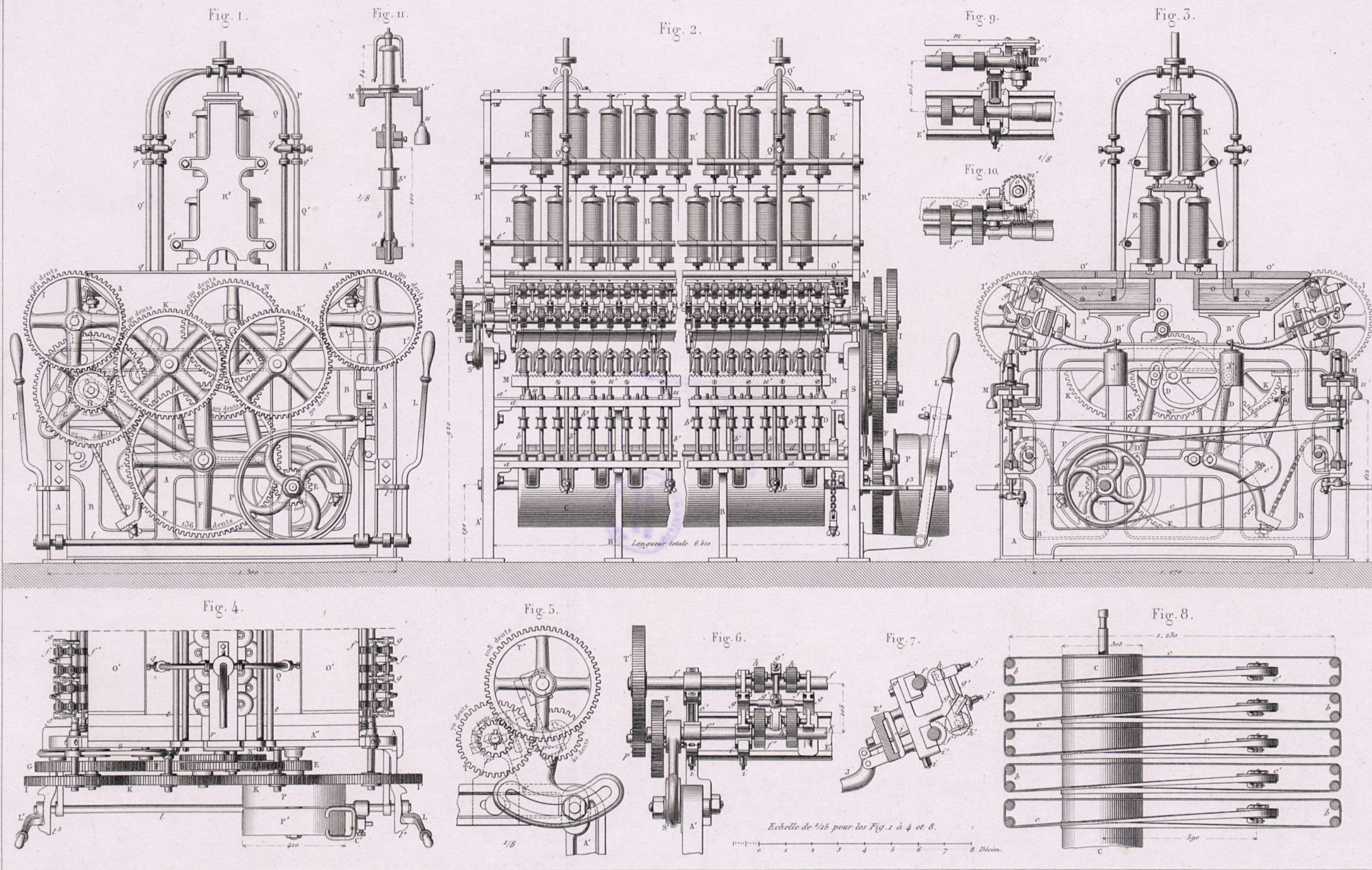

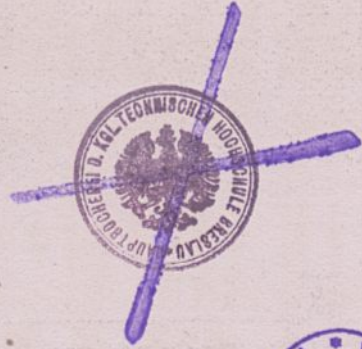

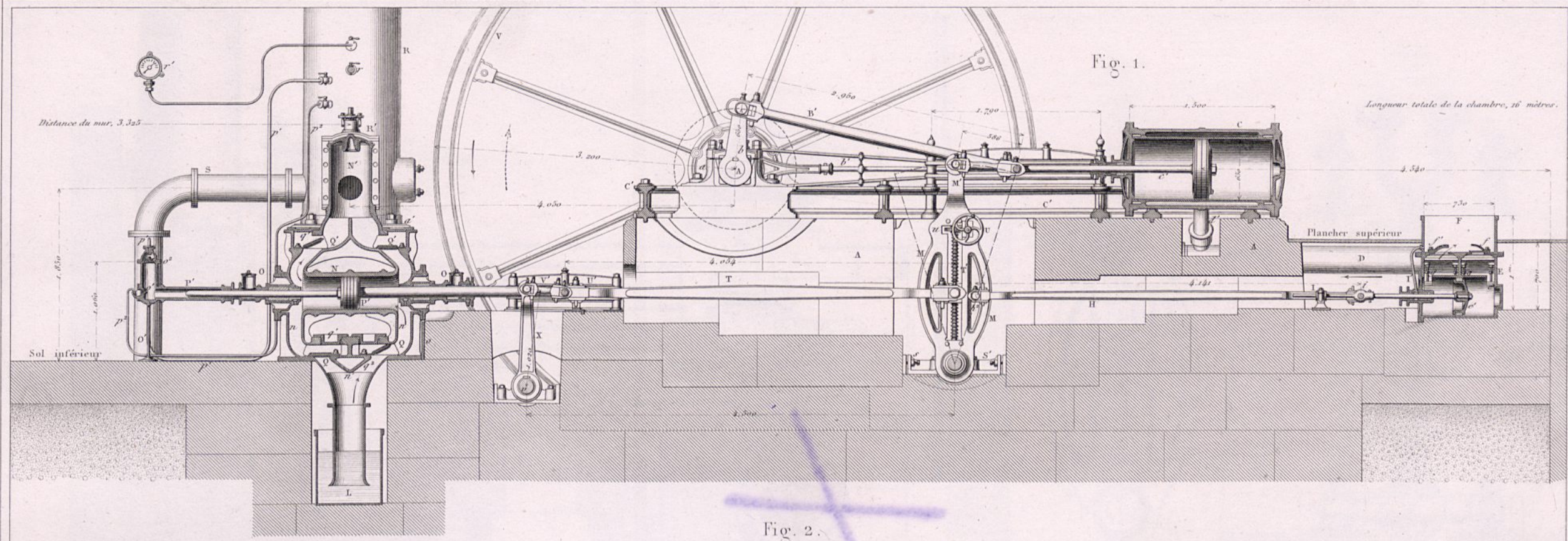
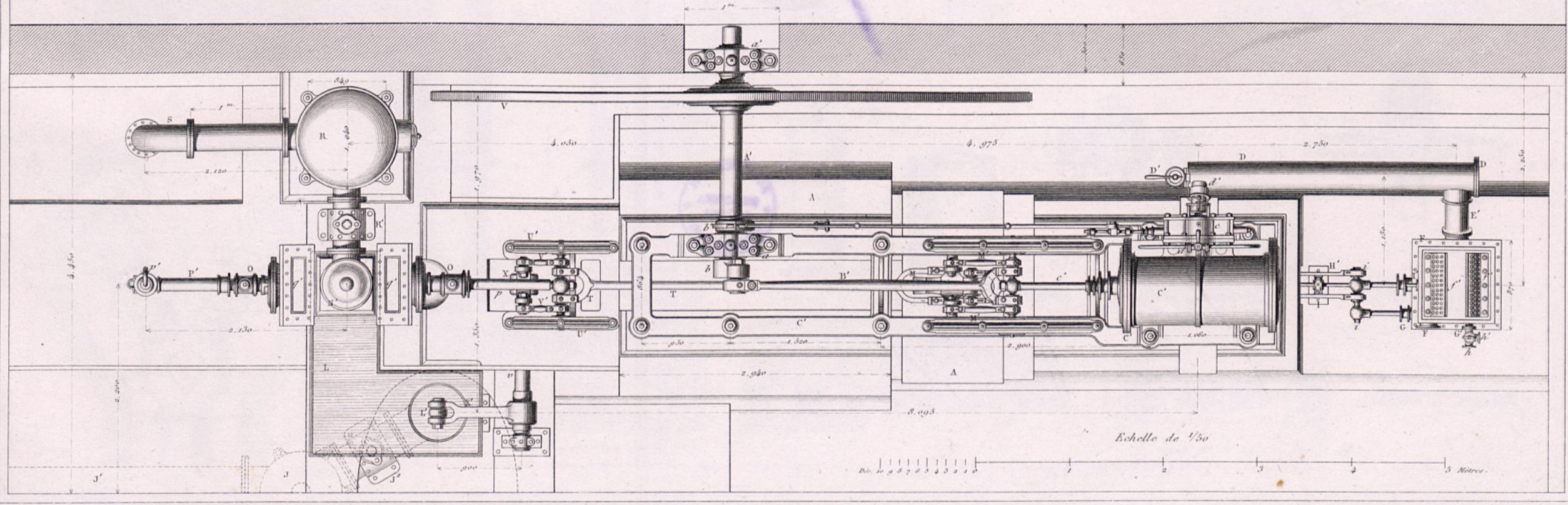

Fig. 2.





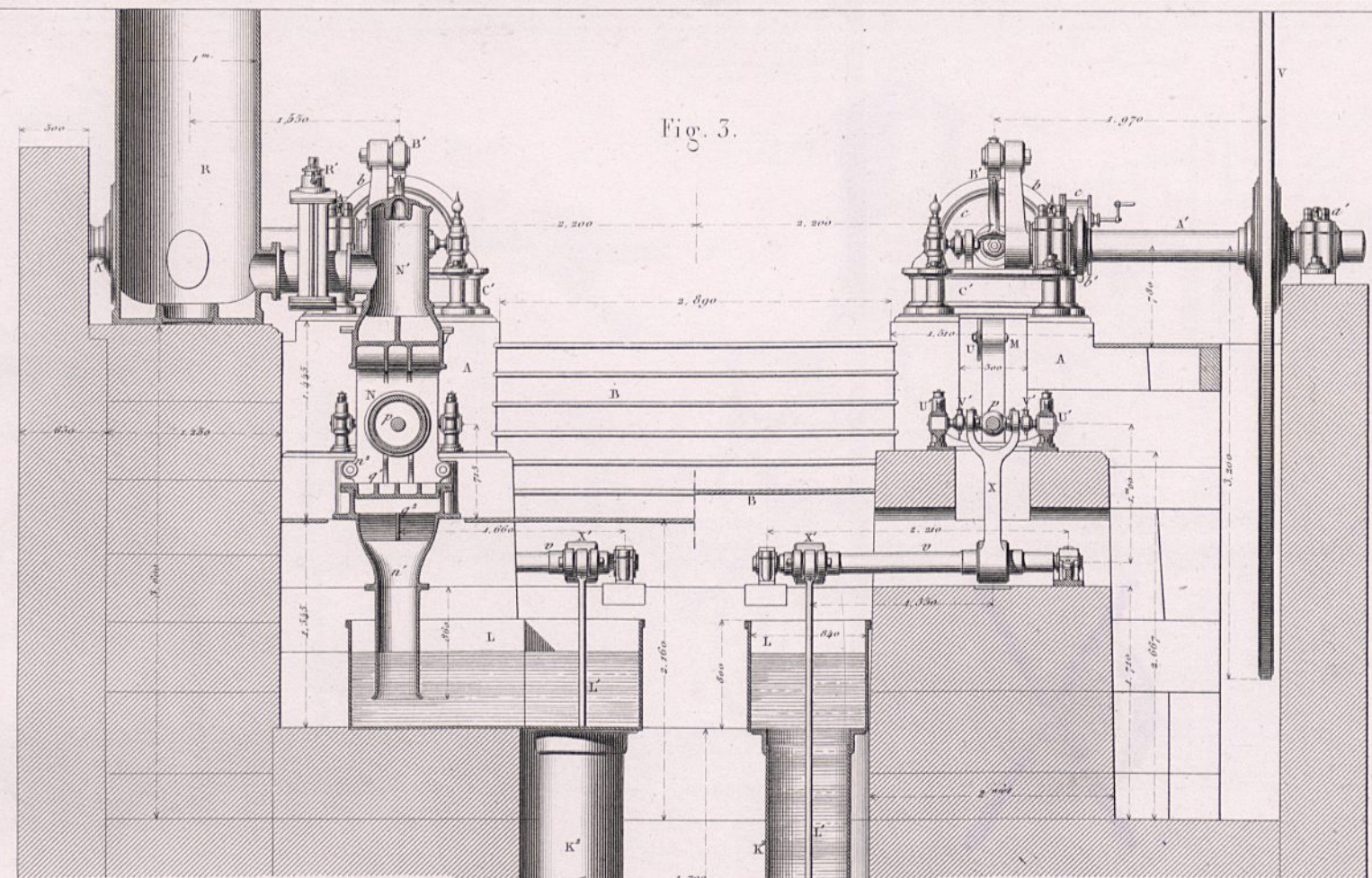

Fig. 5.

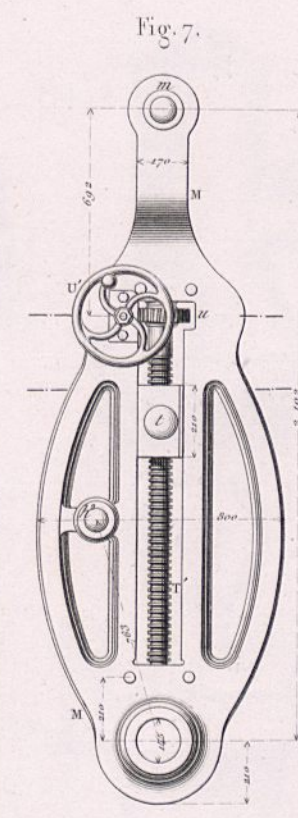

Fig. 7.

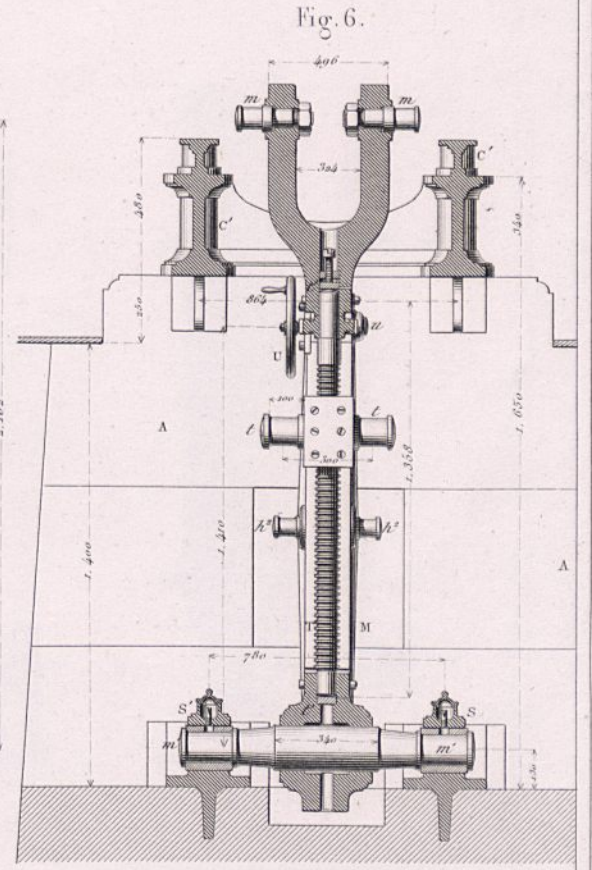

Fig. 6.

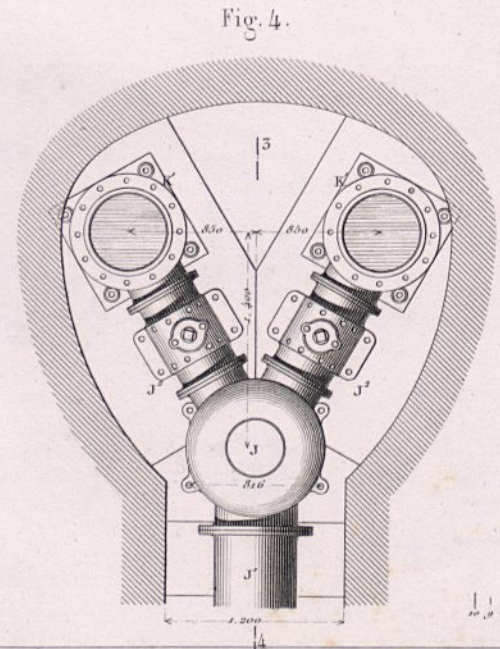

Fig. 4.

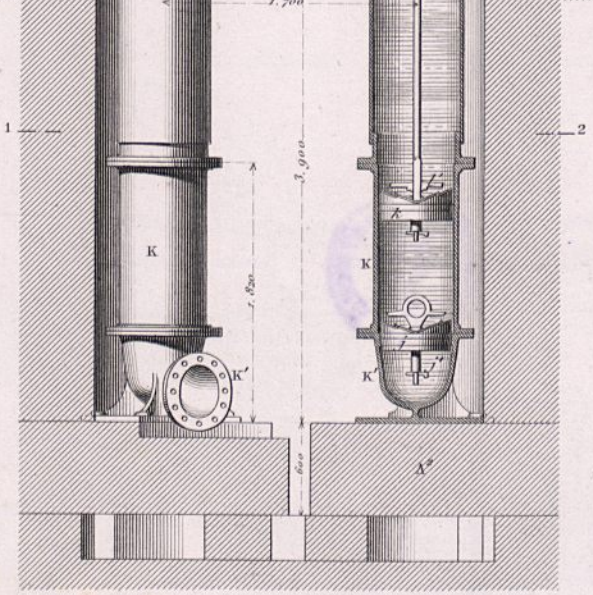

Fig. 5.

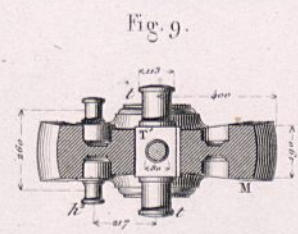
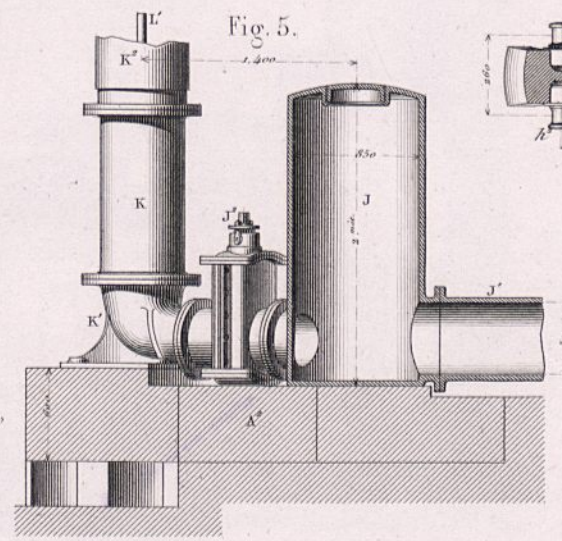

Fig. 9.

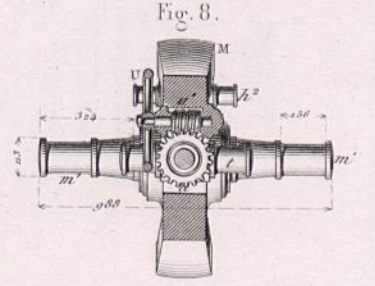

Fig. 8.

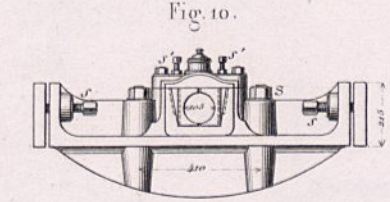

Fig. 10.

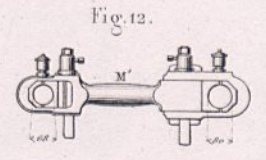

Fig. 12.

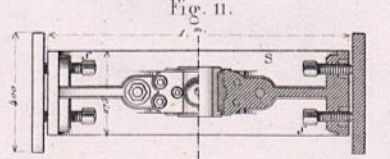

Fig. 11.

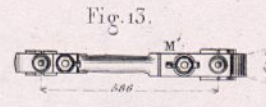
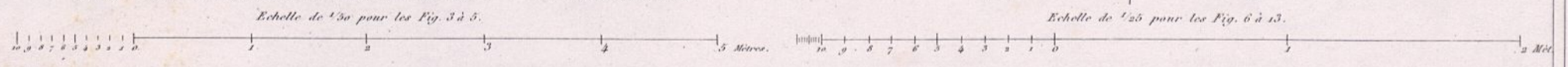
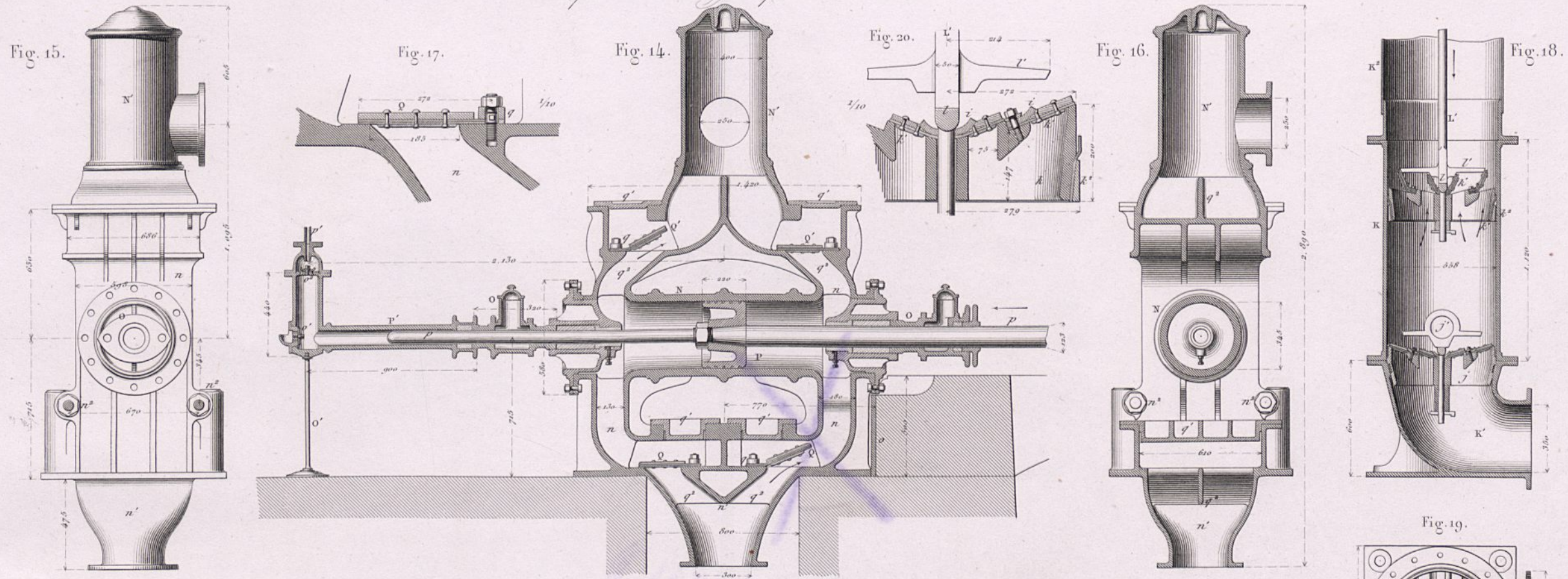

Fig. 13.





Pompe à double effet, par M. Farcot.



Machine élévatrice établie à Yarmouth.

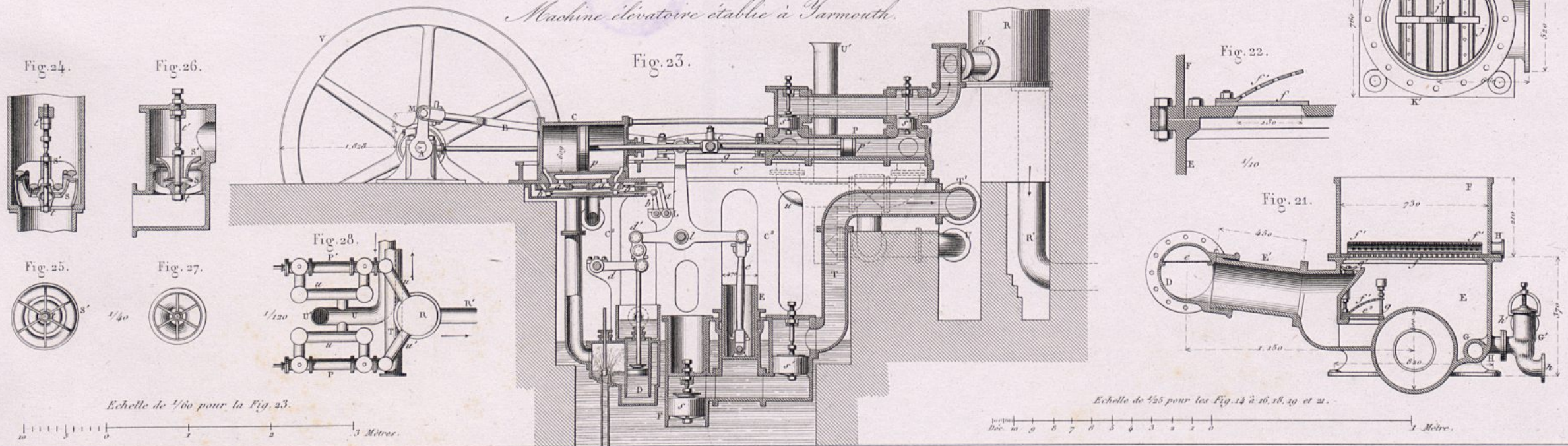



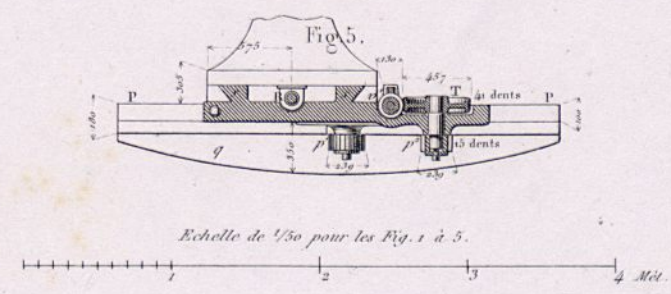
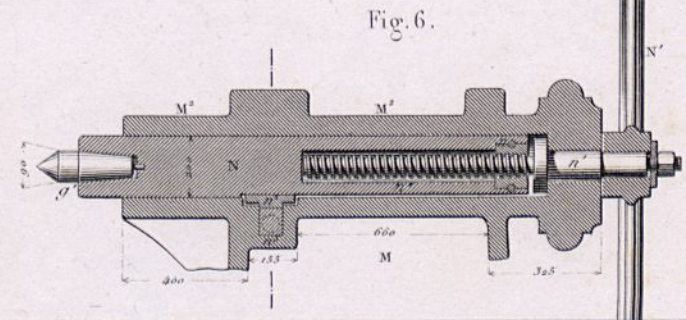
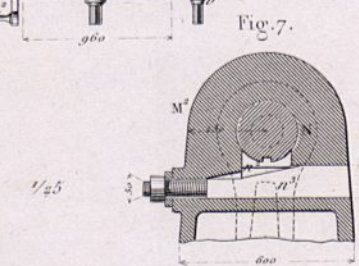
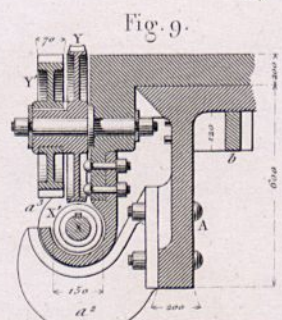
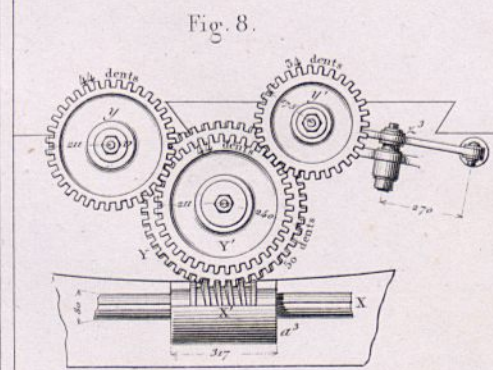
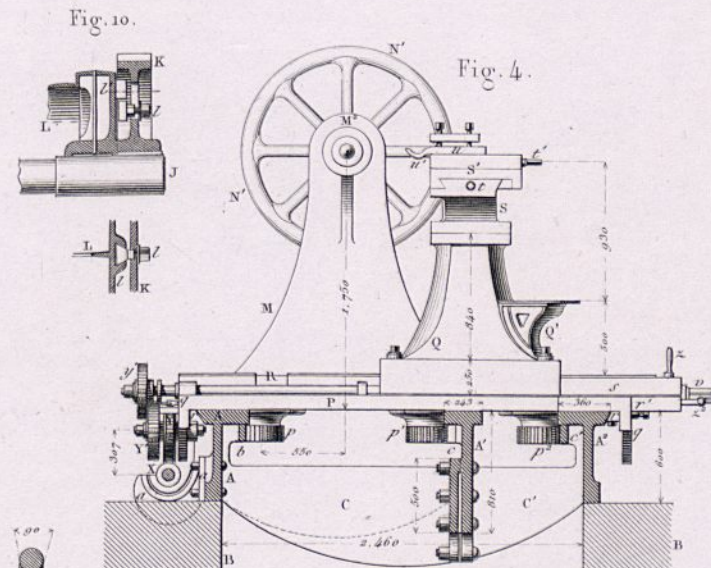
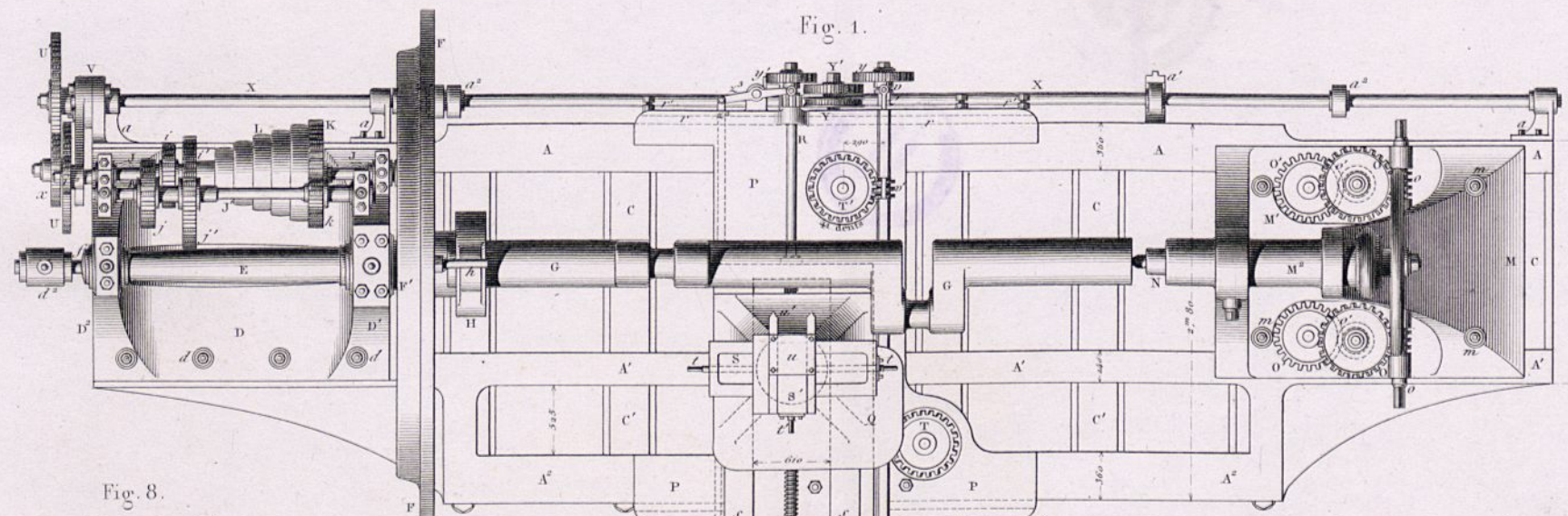
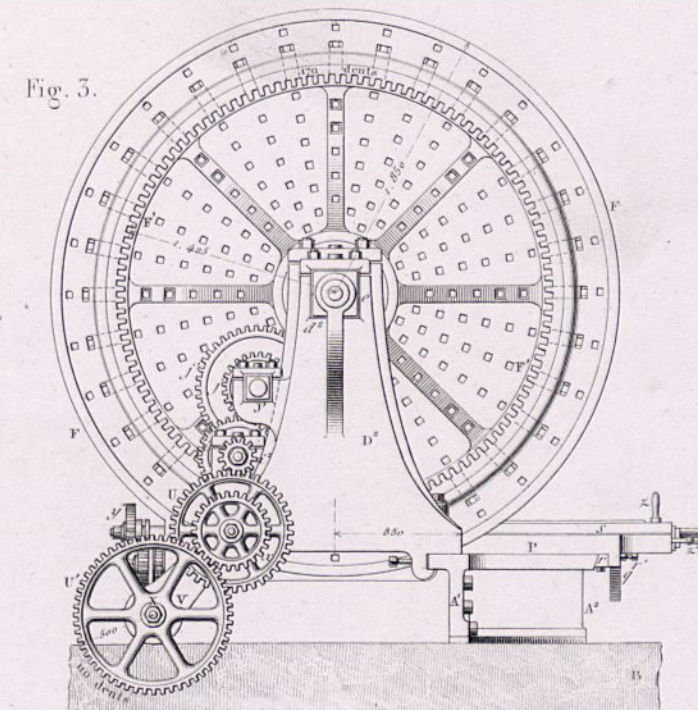
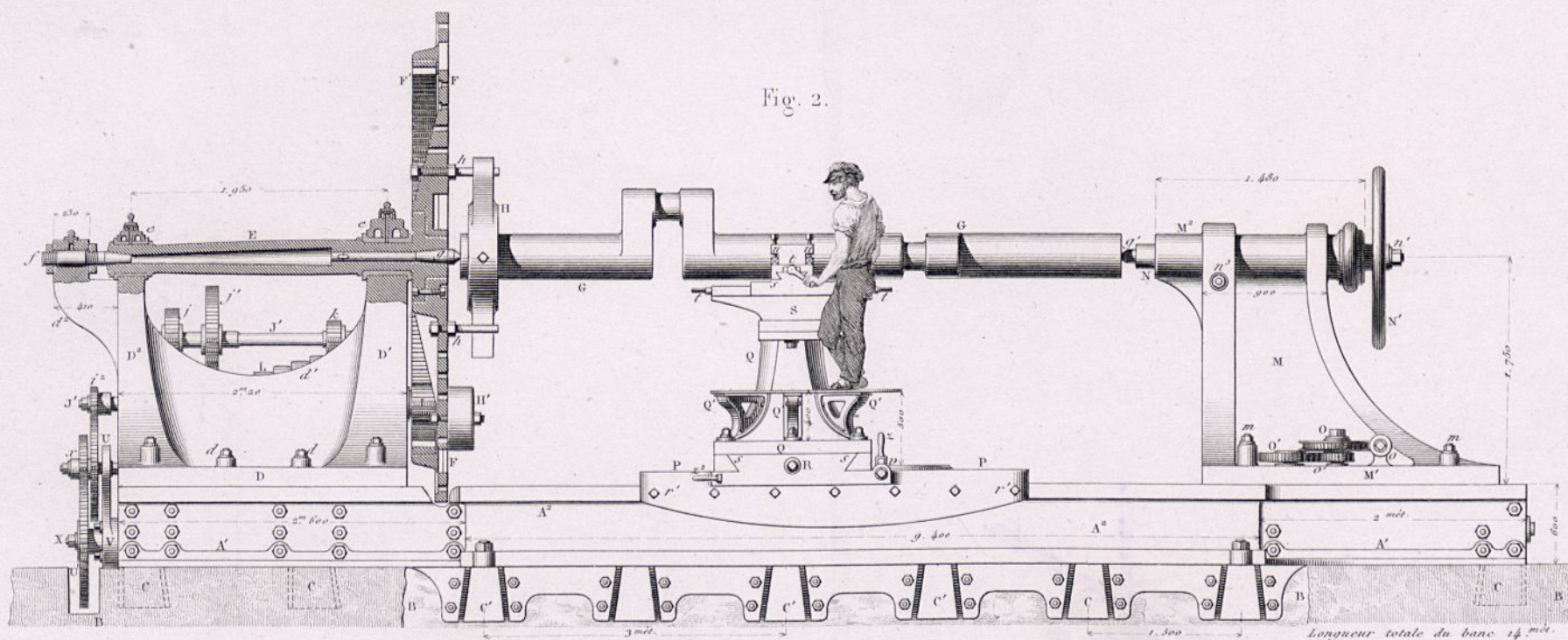

Echelle de 1/50 pour les Fig. 1 à 5.



Grue à pivot fixe, de 10 tonnes.

Grue roulante à pivot.

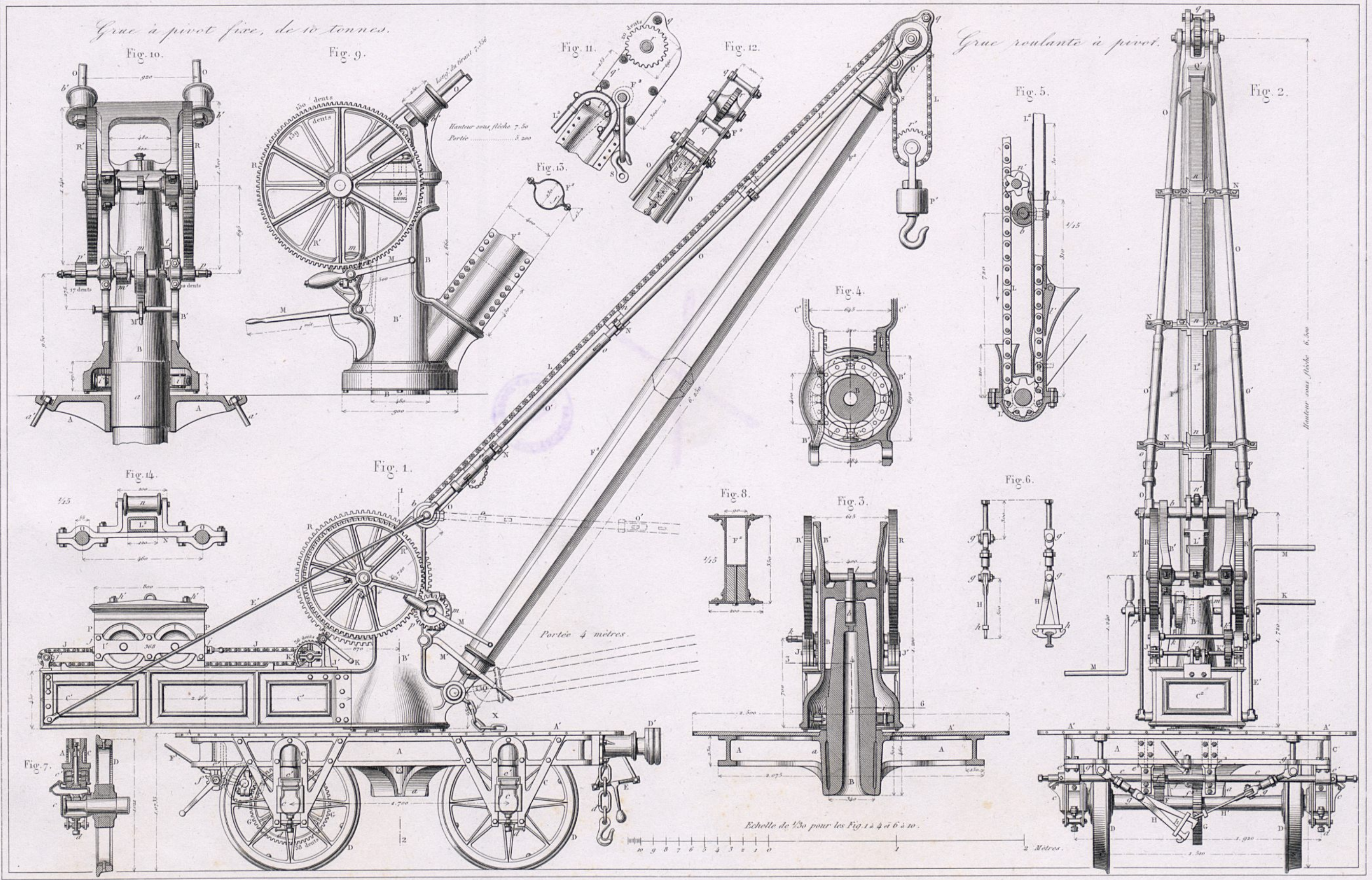



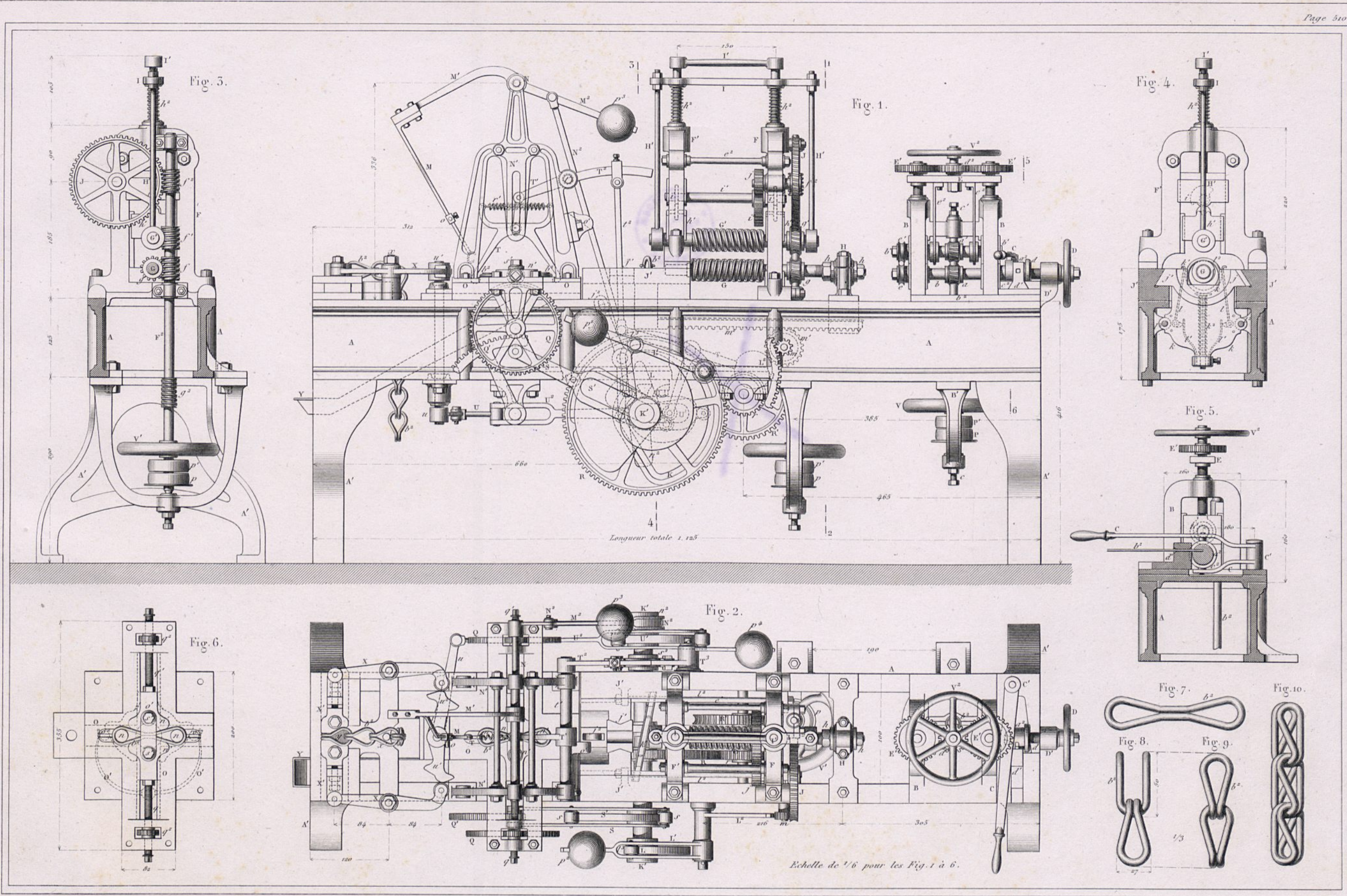



 BIBLIOTEKA GŁÓWNA
R-96 m
ARCHIWUM