

Biblioteka Główna i OINT  
Politechniki Wrocławskiej



100100234412

Wsk 100 ~~F 100~~

10/13 10  
Wsk

A 405 III

~~Wsk~~

90  
2







# ATLAS

ZUR

## ZEITSCHRIFT FÜR BAUWESEN.

HERAUSGEGEBEN

UNTER MITWIRKUNG DER KÖNIGL. TECHNISCHEN BAU-DEPUTATION UND DES  
ARCHITEKTEN-VEREINS ZU BERLIN.

REDIGIRT

VON

**G. ERBKAM,**

BAURATH IM KÖNIGLICHEN MINISTERIUM FÜR HANDEL, GEWERBE UND ÖFFENTLICHE ARBEITEN.

1911.1702.

**JAHRGANG XVI.**



8420



Abgegeben

von der

**Bücherei**

BERLIN, 1866.  
VERLAG VON ERNST & KORN.  
(GROPIUS'SCHE BUCH- UND KUNSTHANDLUNG.)

der Kgl. Technischen  
Hochschule Danzig.



ATLAS

ZEITSCHRIFT FÜR ARCHITECTUR-UND BAUWISSENSCHAFTEN



ENTWURF UND AUSFÜHRUNG DER ARCHITECTUR-UND BAUWISSENSCHAFTEN



1877

VERLAG VON C. ERDMANN









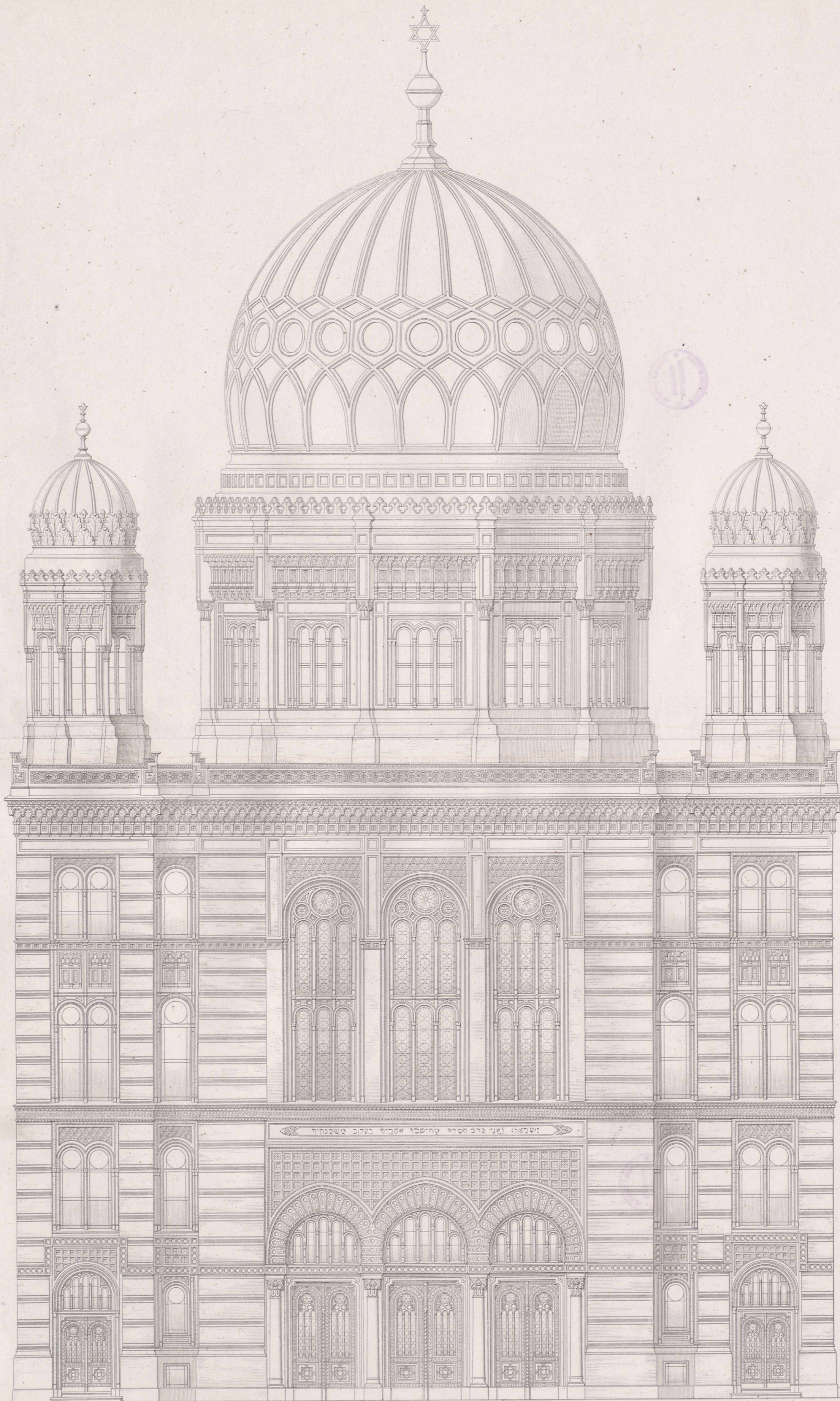



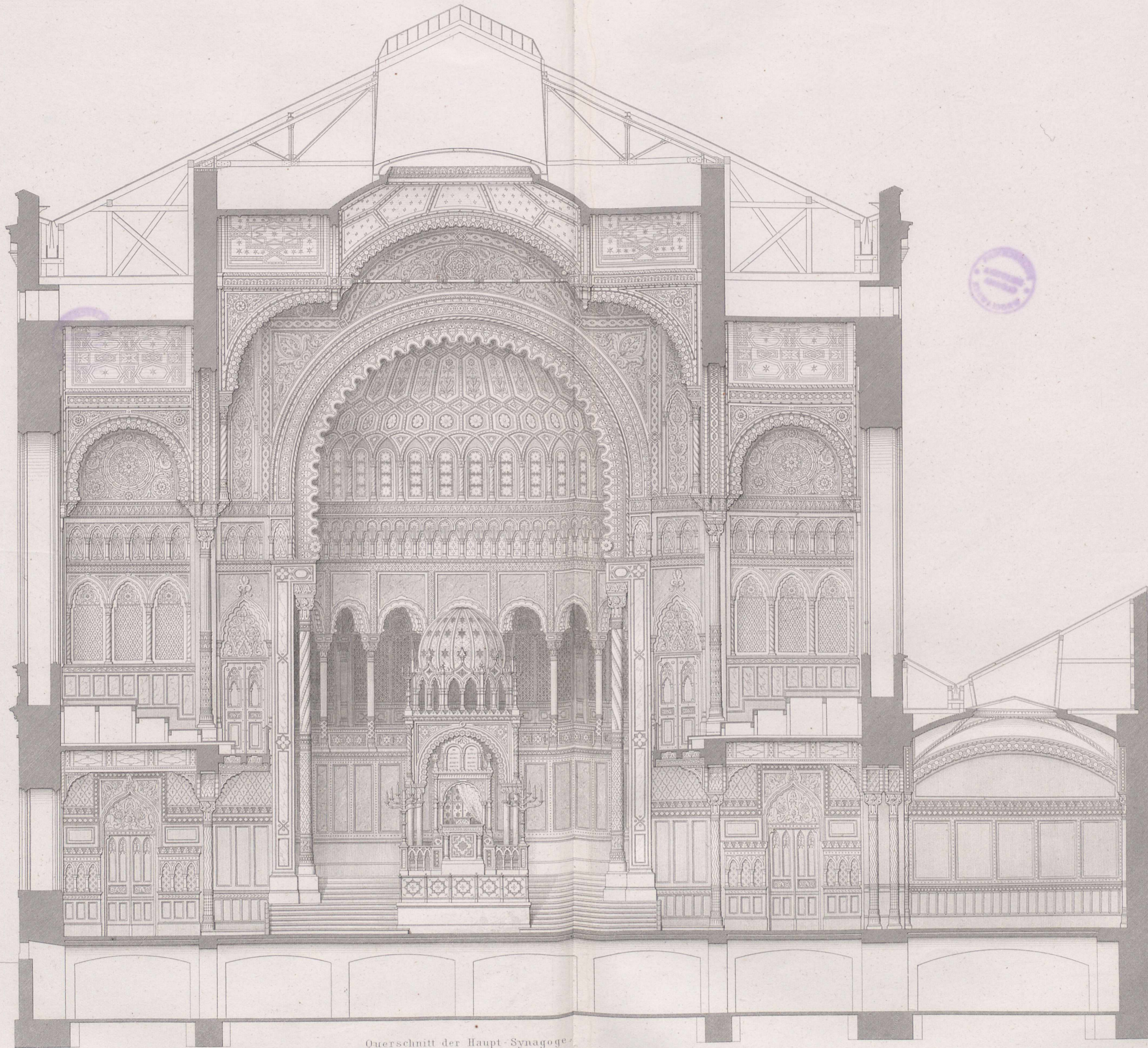

Querschnitt der Haupt-Synagoge

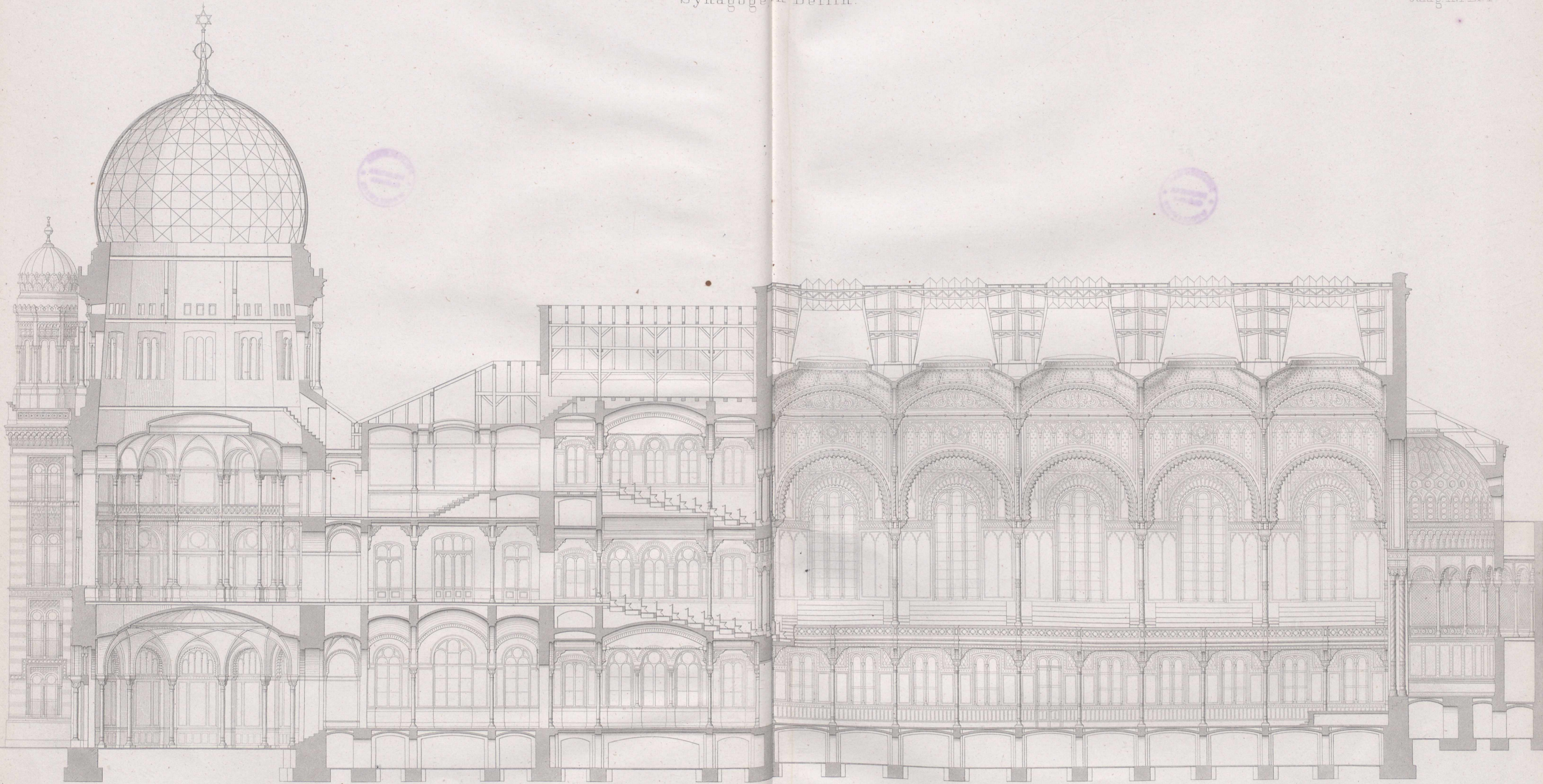

Längendurchschnitt.

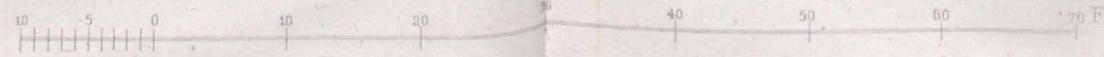

Ernst & Korn, Berlin.

Verblacherf.

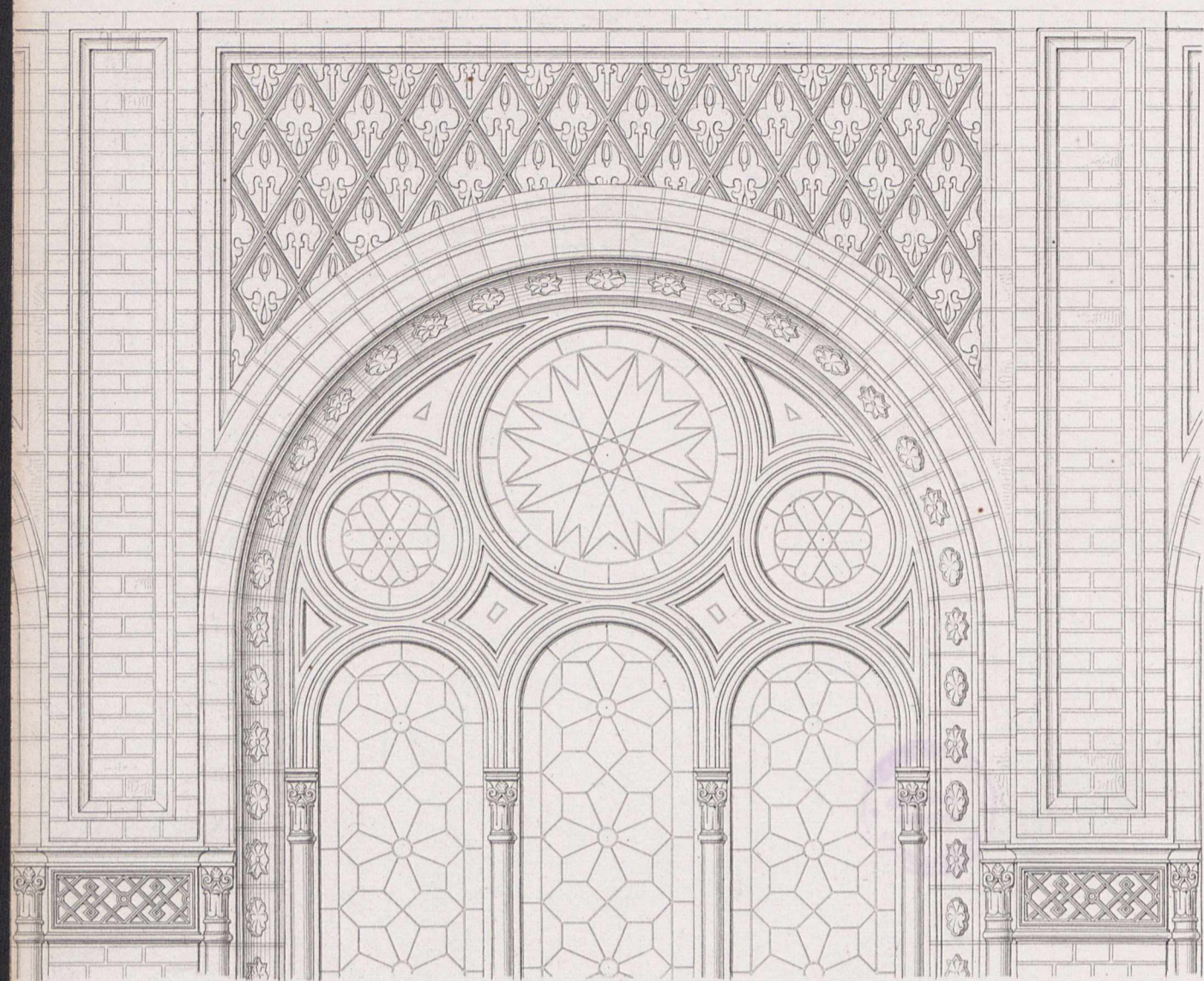

Details der mittleren Fenster.

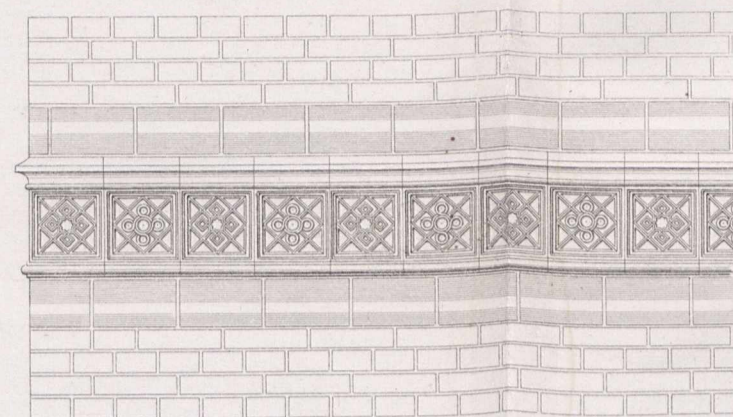

Brüstungsgesims des obersten Geschosses.

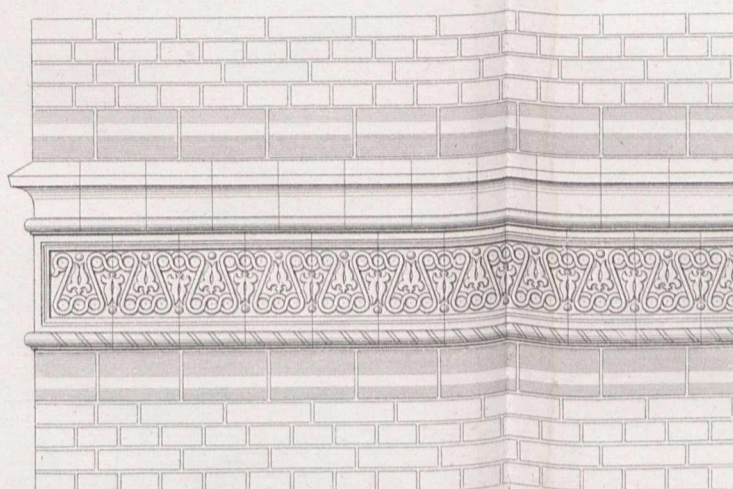

Brüstungsgesims des Hauptgeschosses.

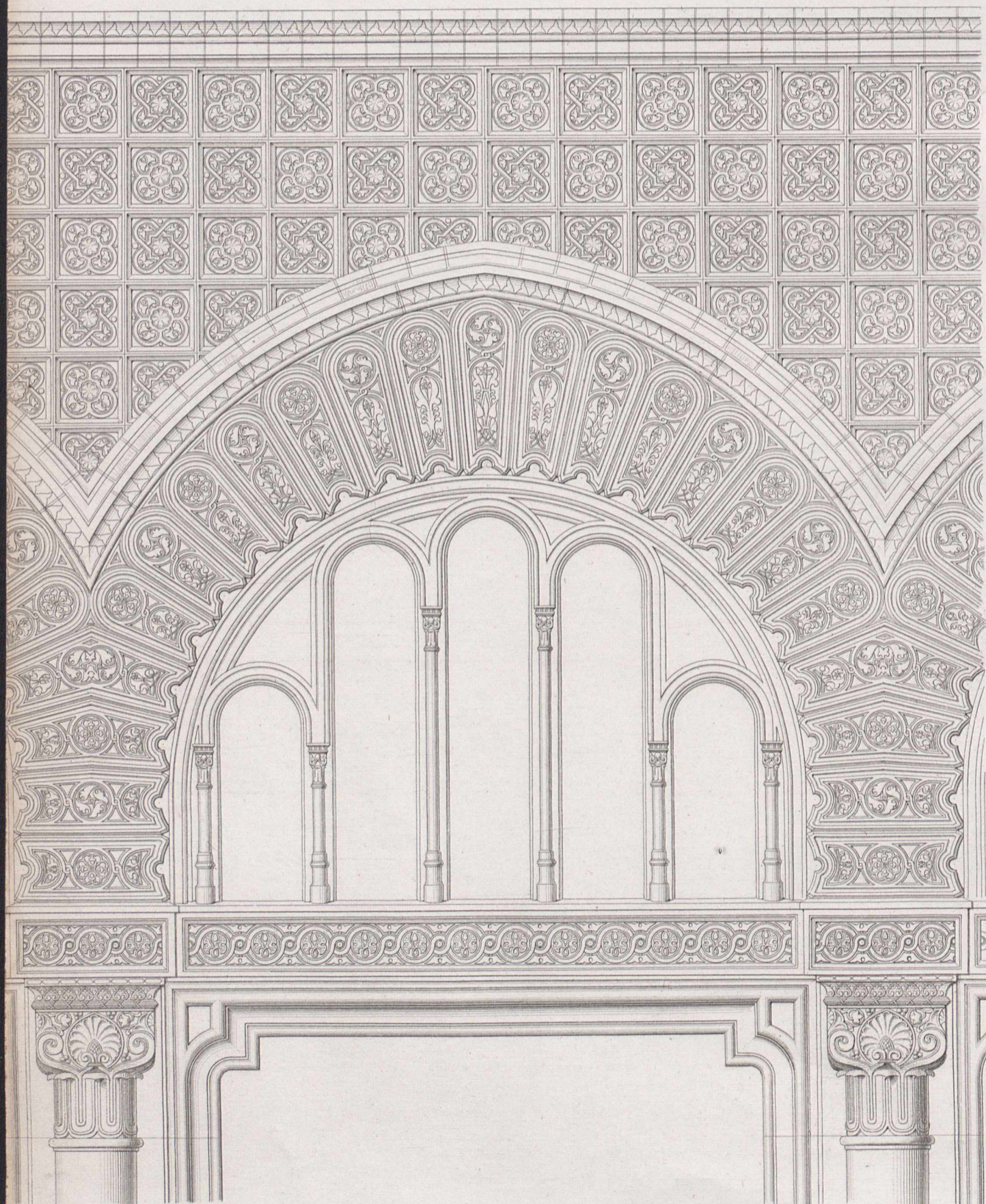

Detail der mittleren Eingangsportale.

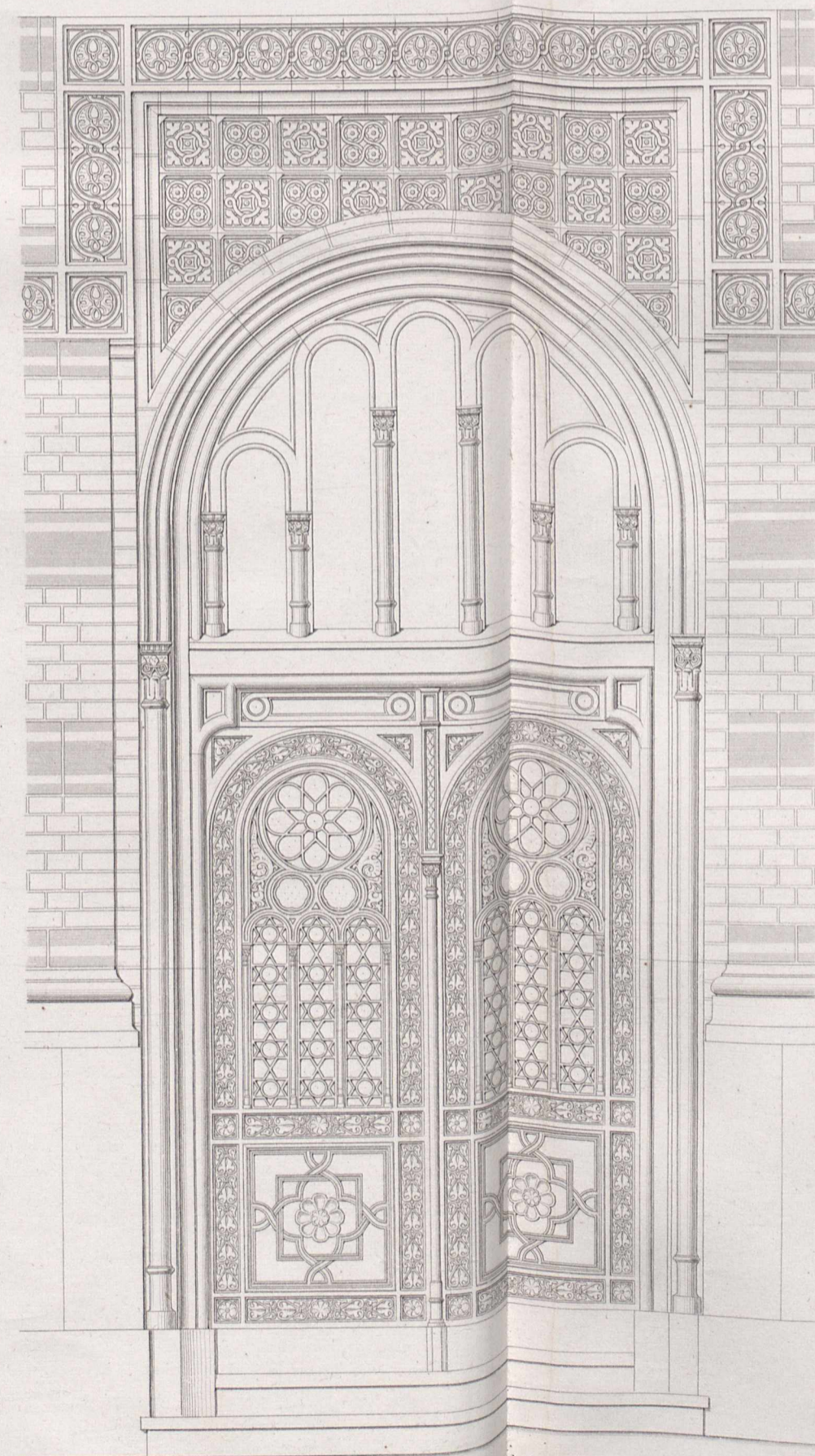

Seitliche Eingangstür

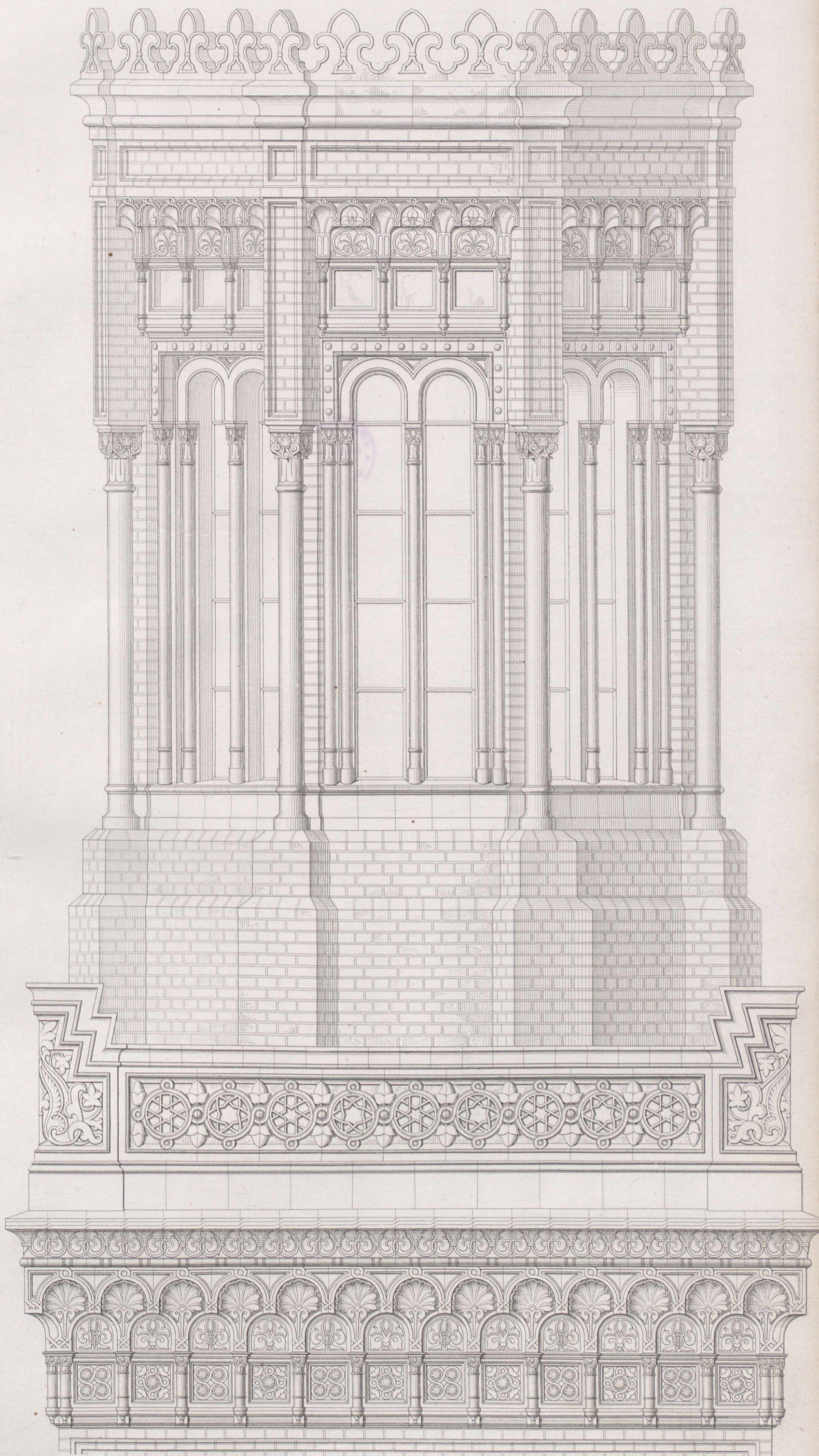

Detail des Hauptgesimses der Attika und des Tambours der kleinen Kuppeln.

10 0 0 1 2 3 4 5 7 8 9 10 11 Fuss Pr

Eisenconstruktionen.

Fig. 1 Querschnitt.

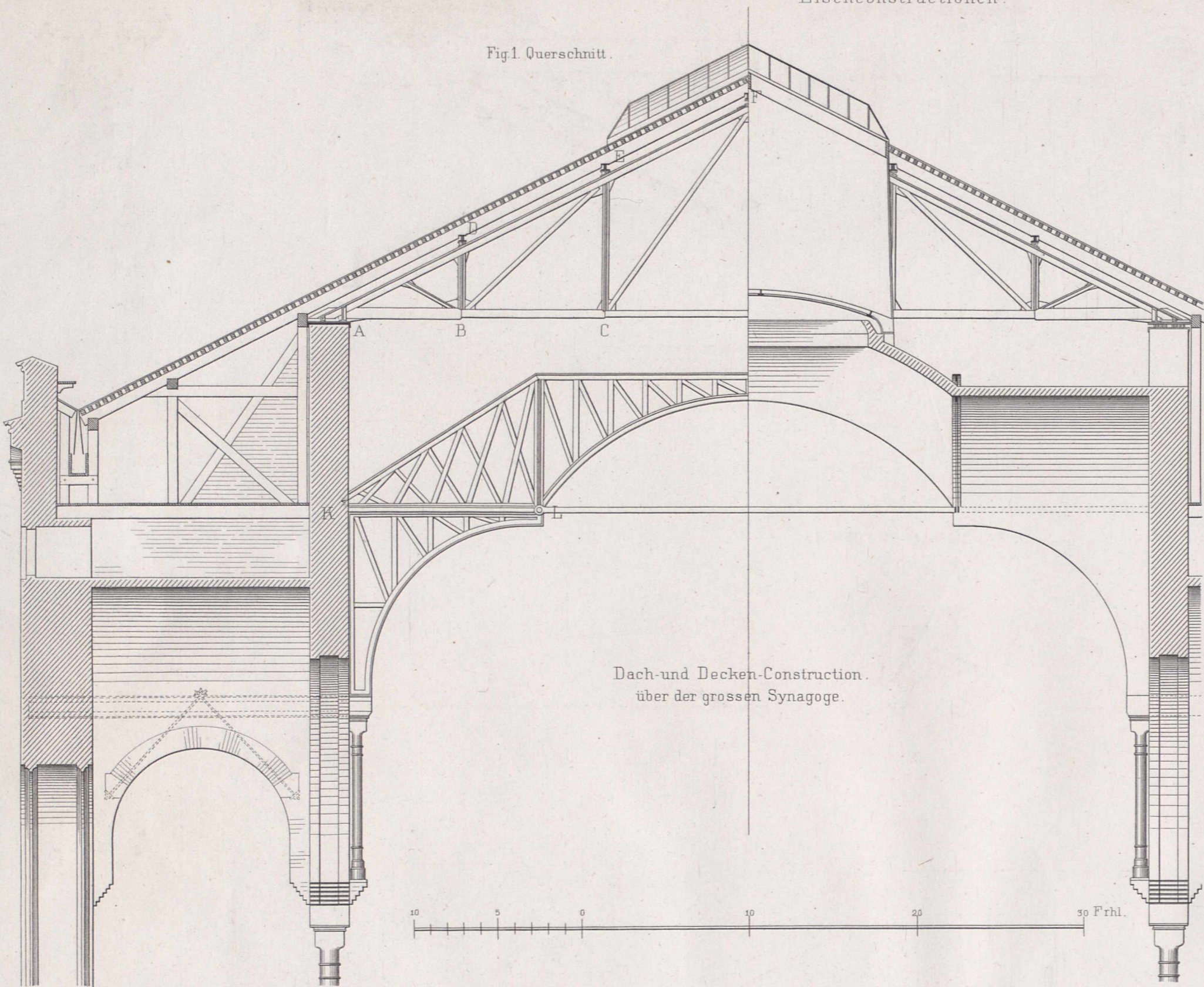

Dach- und Decken-Construction über der grossen Synagoge.

Fig. 2 Längenschnitt.

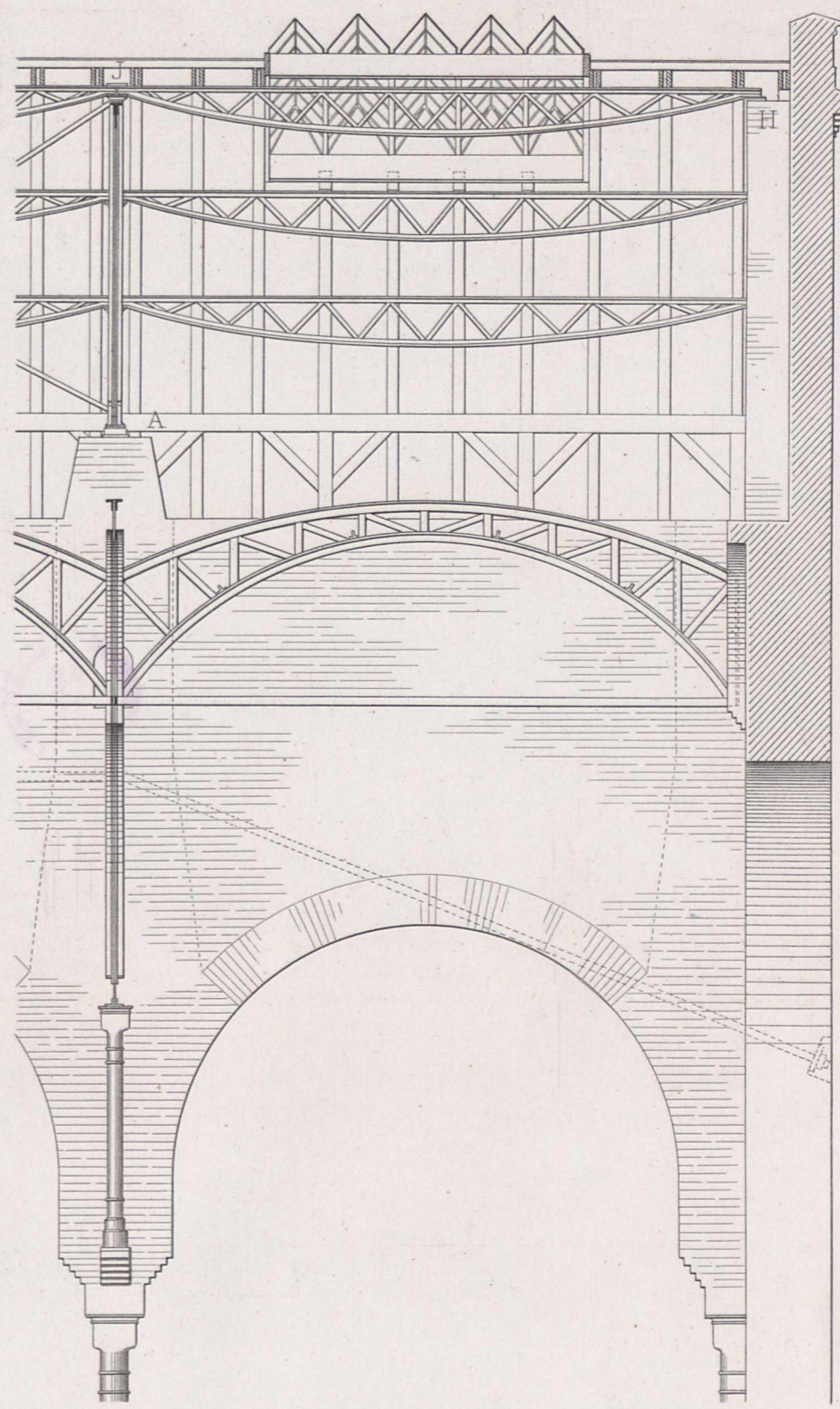
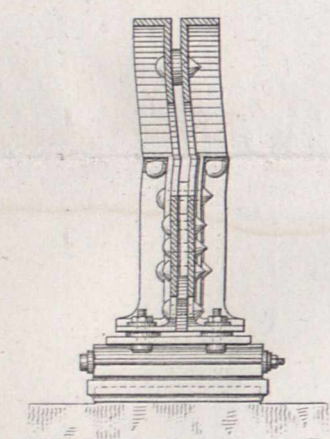

Fig. 3 b.

Schnitt bei MN.



Detail des Auflagers bei A Fig. 1.

Fig. 3 a.

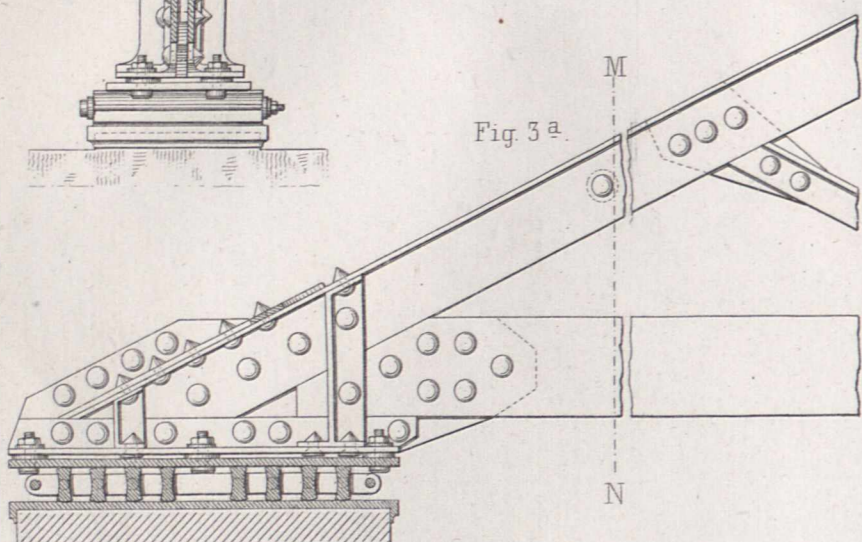

2 Eckisen à 2 1/2" u. 3/8" stark.

Detail bei D Fig. 1.

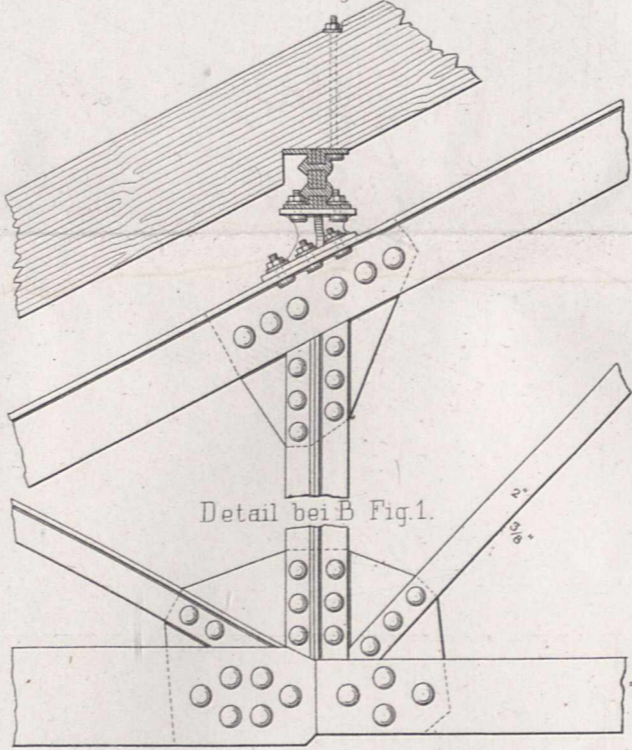

Detail bei B Fig. 1.

Detail bei E Fig. 1.

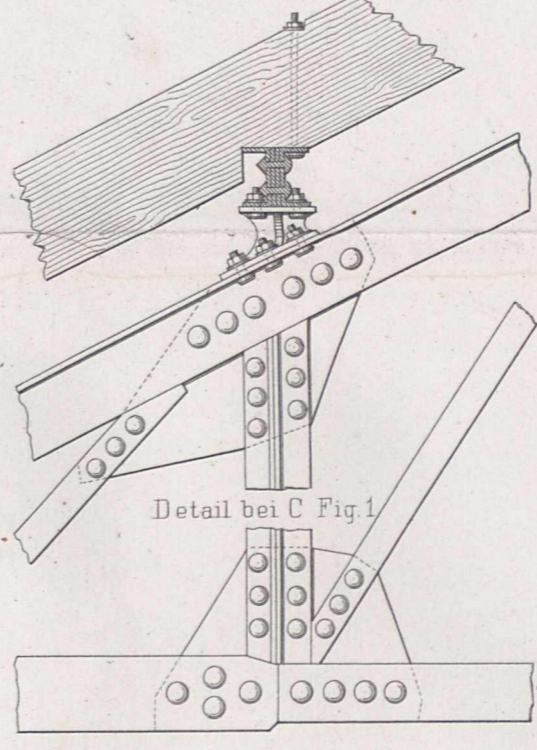

Detail bei C Fig. 1.

Detail bei F Fig. 1.

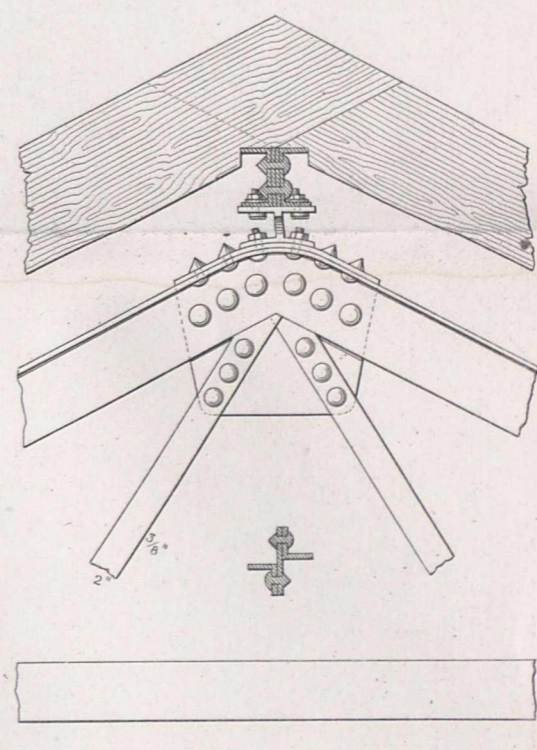

Details der Dachträger.

Auflager H in Fig. 2.

Fig. 4 a.

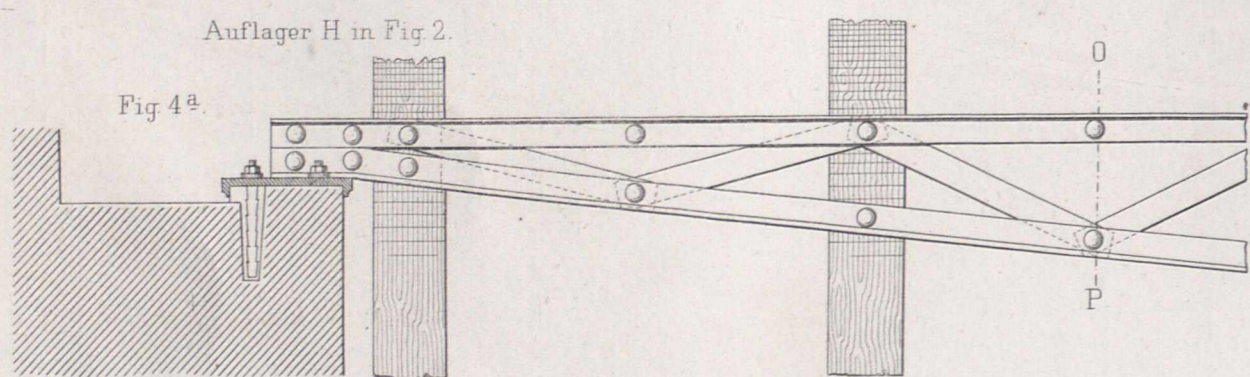

Schnitt bei OP.

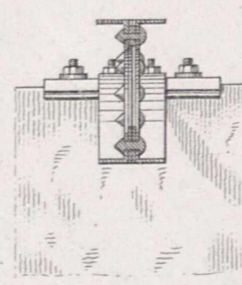

Details der Fellen Fig. 2.

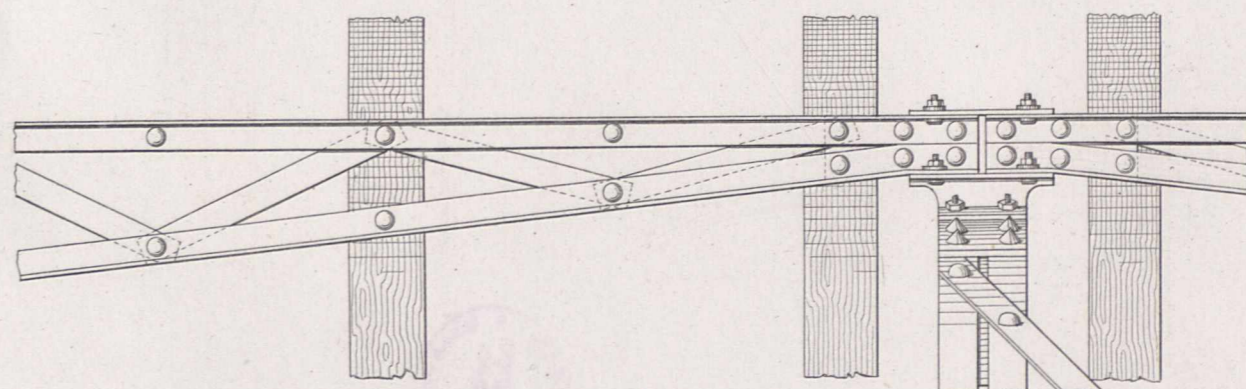

Auflager J in Fig. 2.

Fig. 4 b.

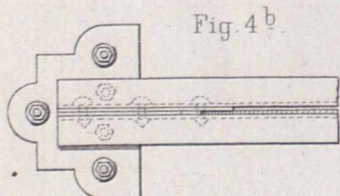

Grundriss bei QR.

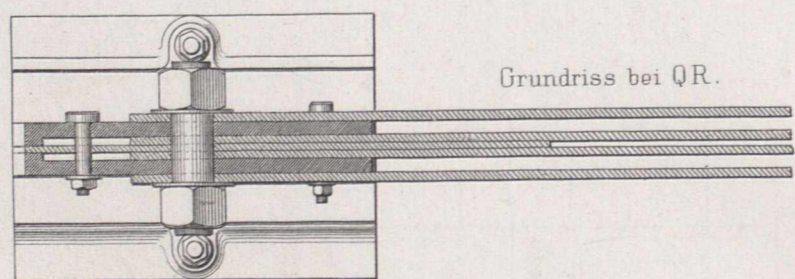

Schnitt bei ST.

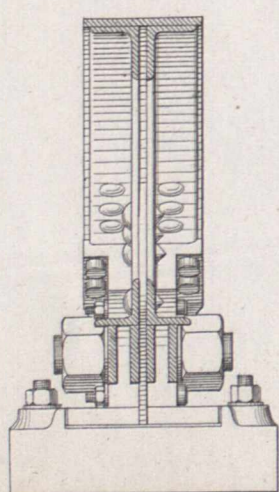

Detail des Auflagers bei K Fig. 1.

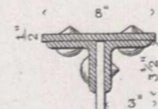
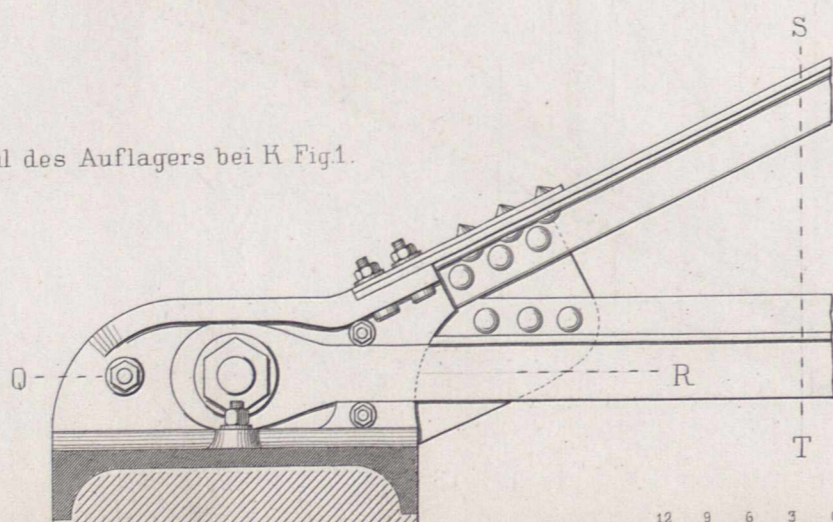

Details der Deckenträger.

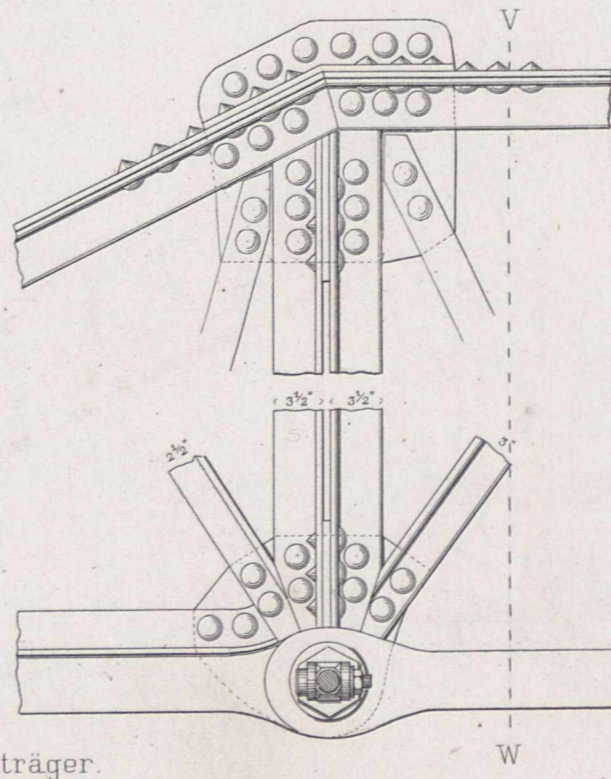

Schnitt bei VW.

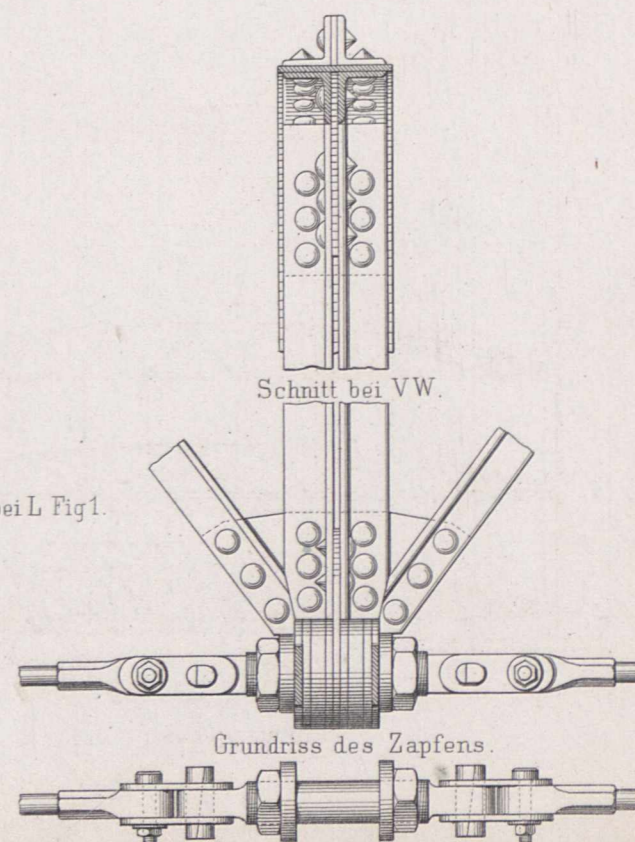

Detail bei L Fig. 1.

Grundriss des Zapfens.

12 9 6 3 0 1 2 3 4 5 Fuhl.



Façade nach dem Bauhof.

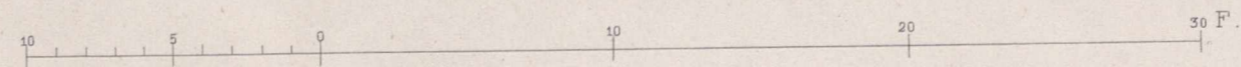



Façade in der Georgenstrasse.

10 5 0 10 20 30 F.

Erdgeschoss.

Bel-Etage.

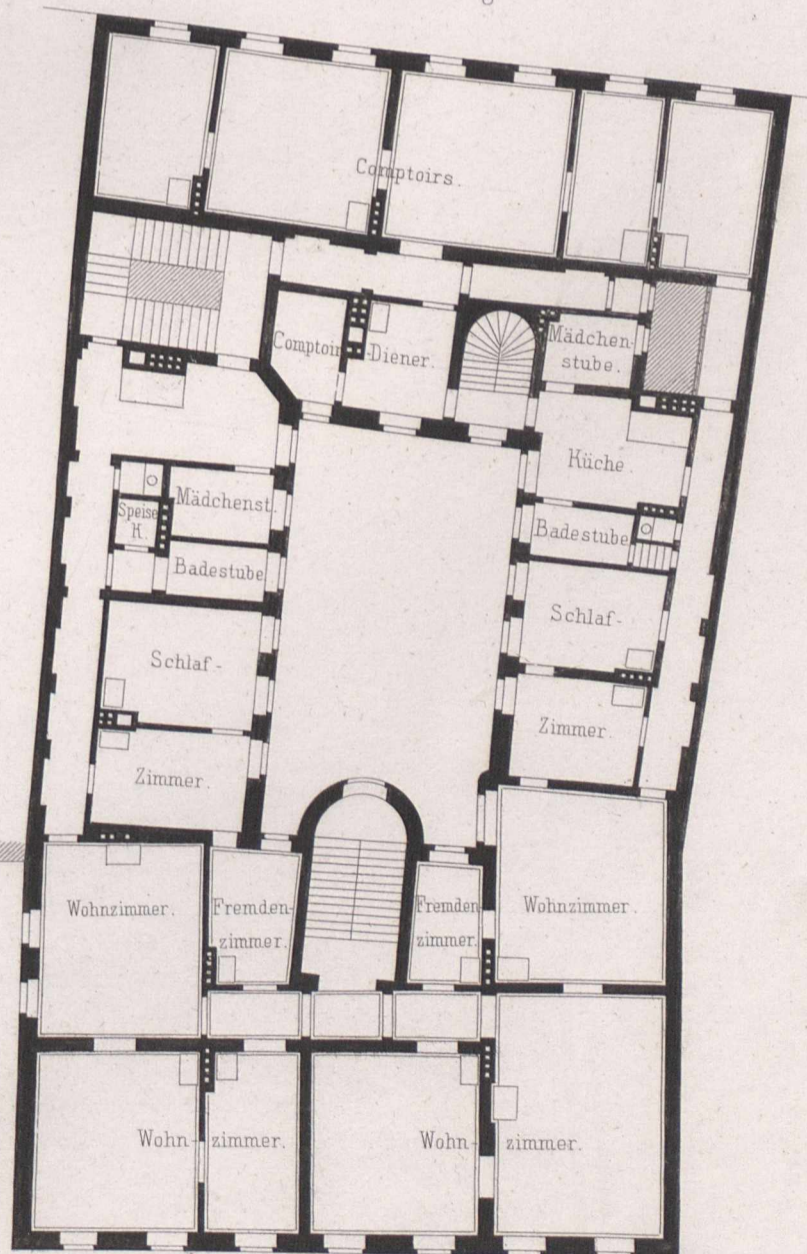
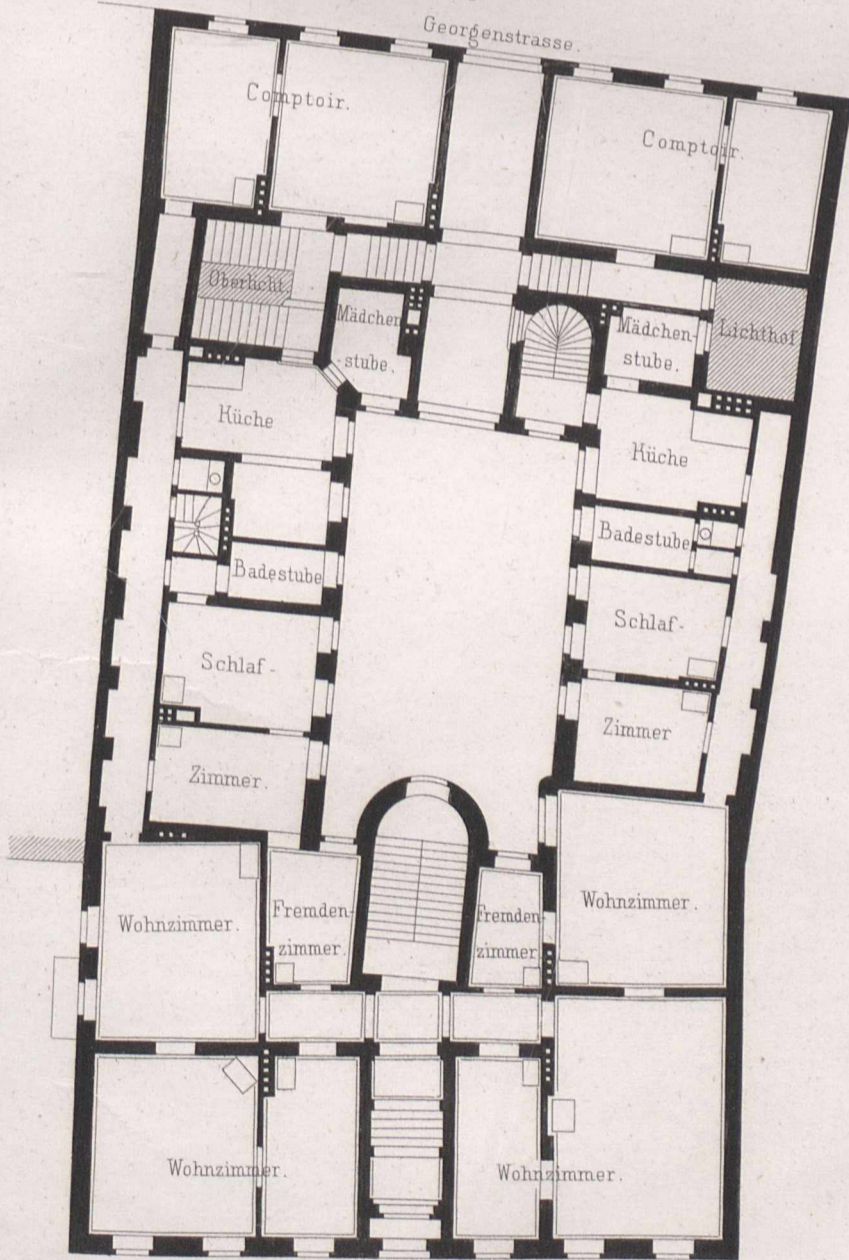

10 5 0 10 20 30 40 50 60 70 80 90 100 F.



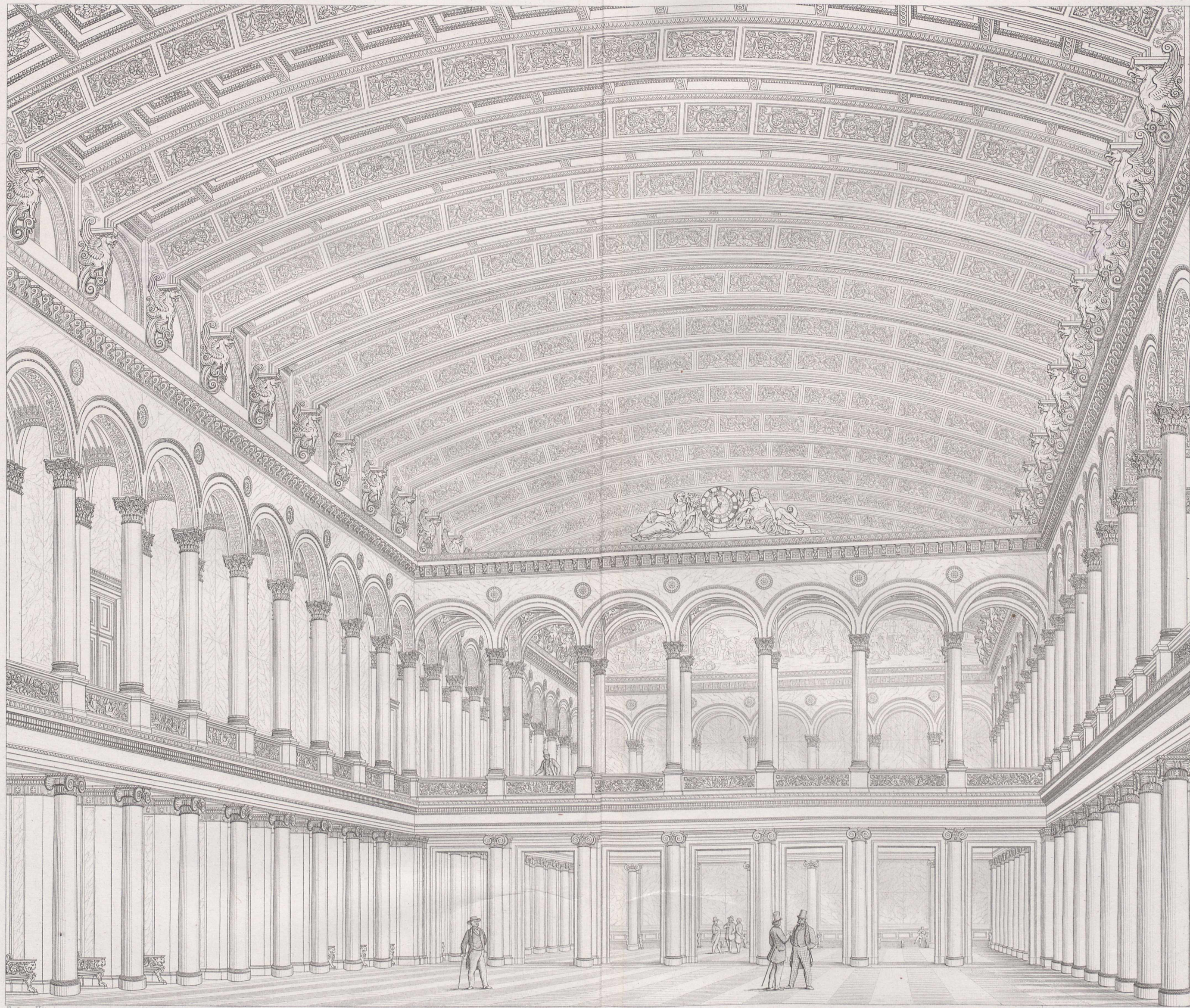

Ent. v. Hitzig

Gest. v. Ritter

Perspectivische Ansicht des Börsensaales.

Verlag von Ernst & Korn in Berlin.

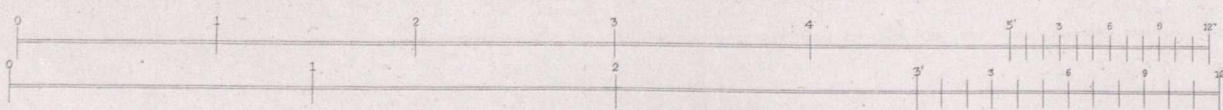
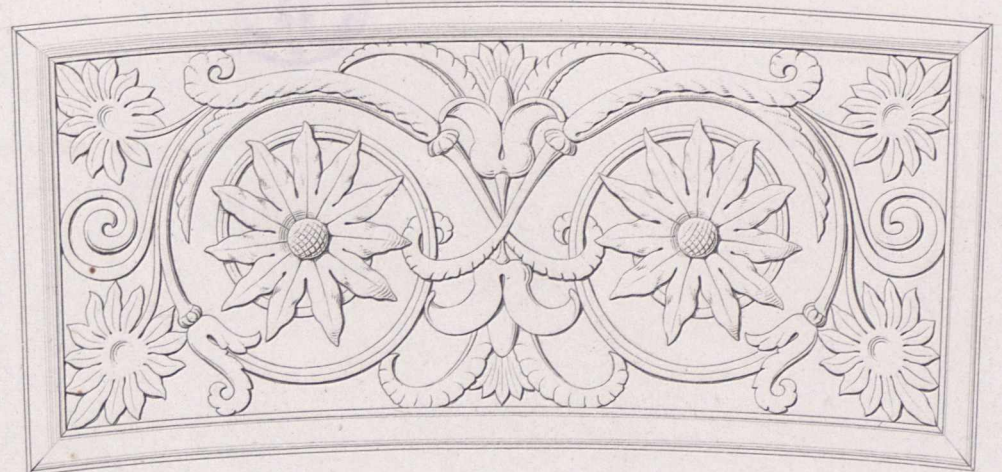
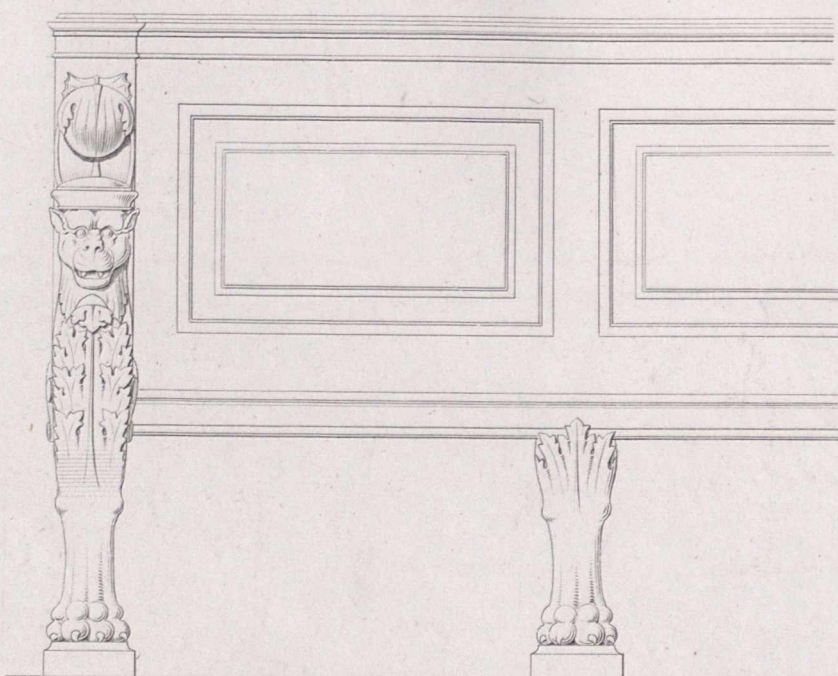
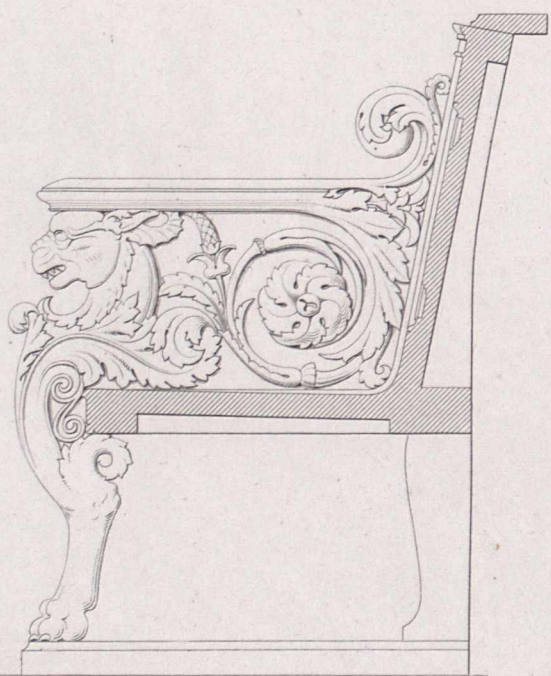
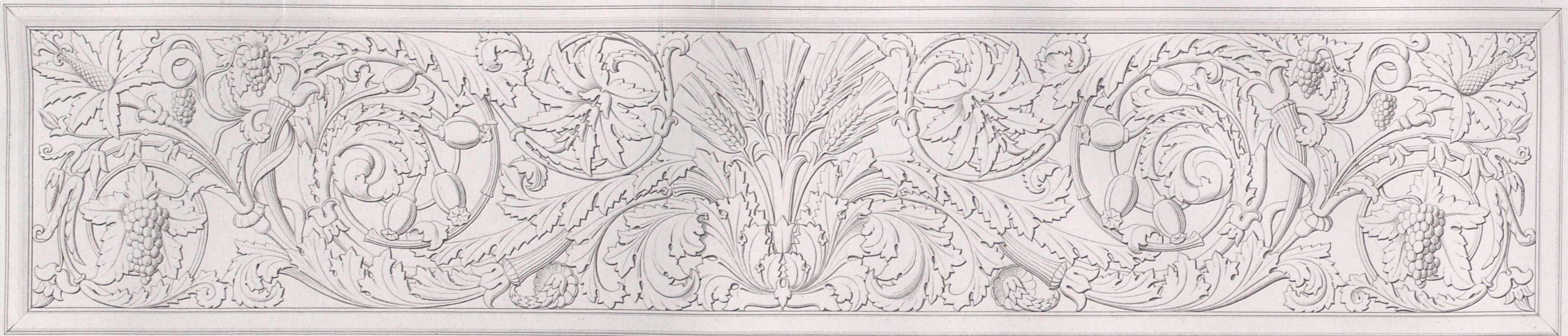
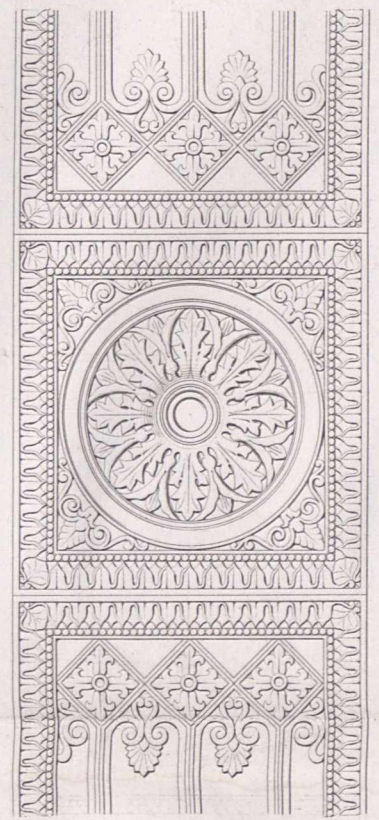
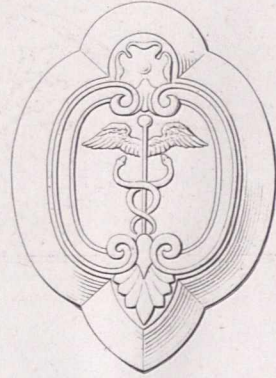
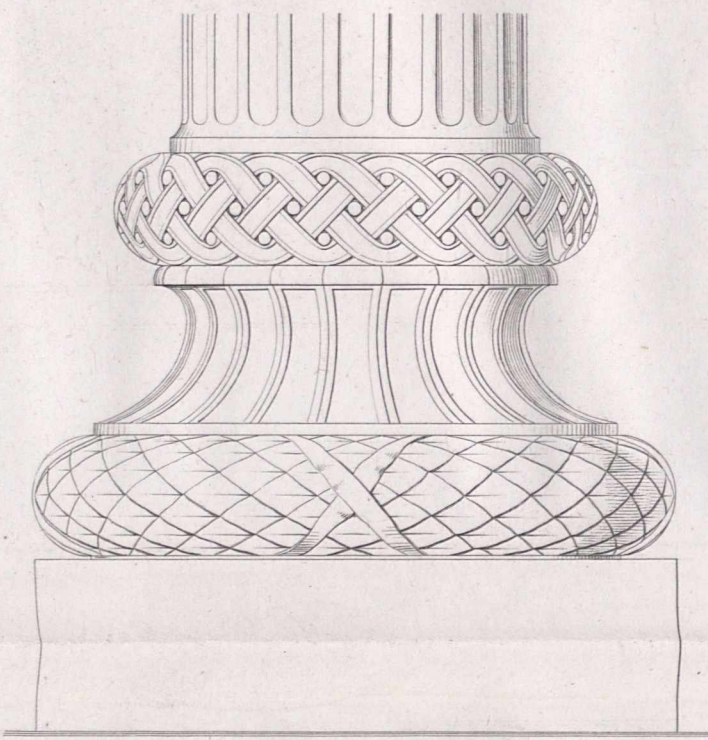
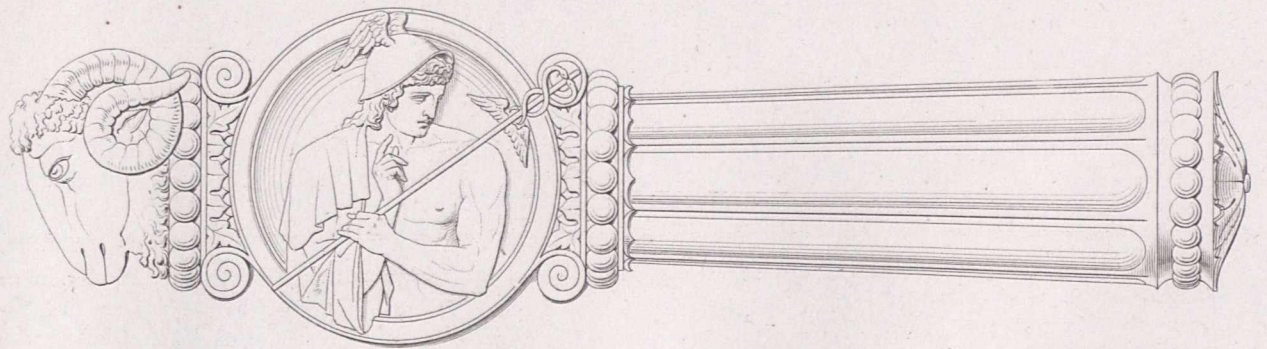
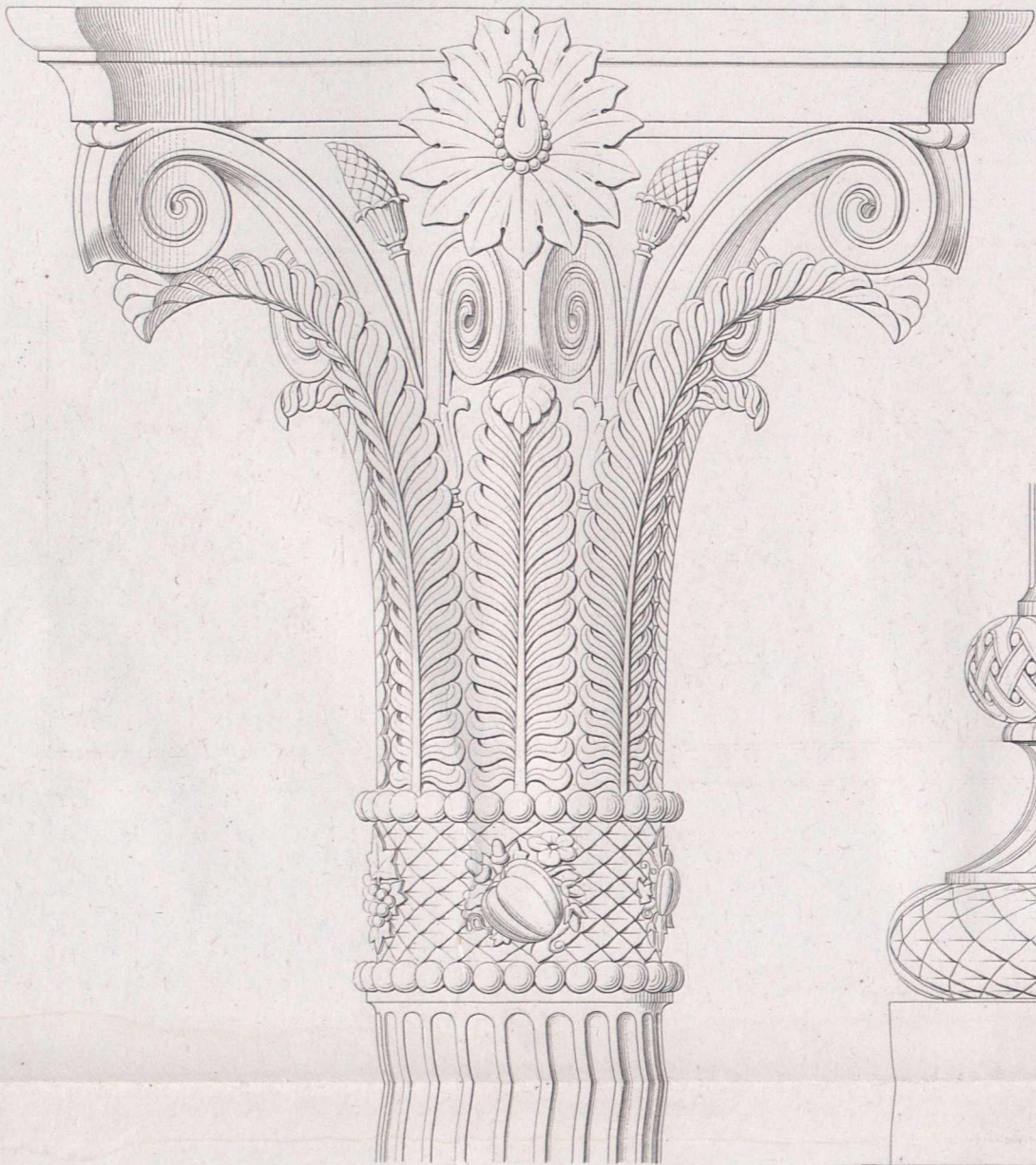
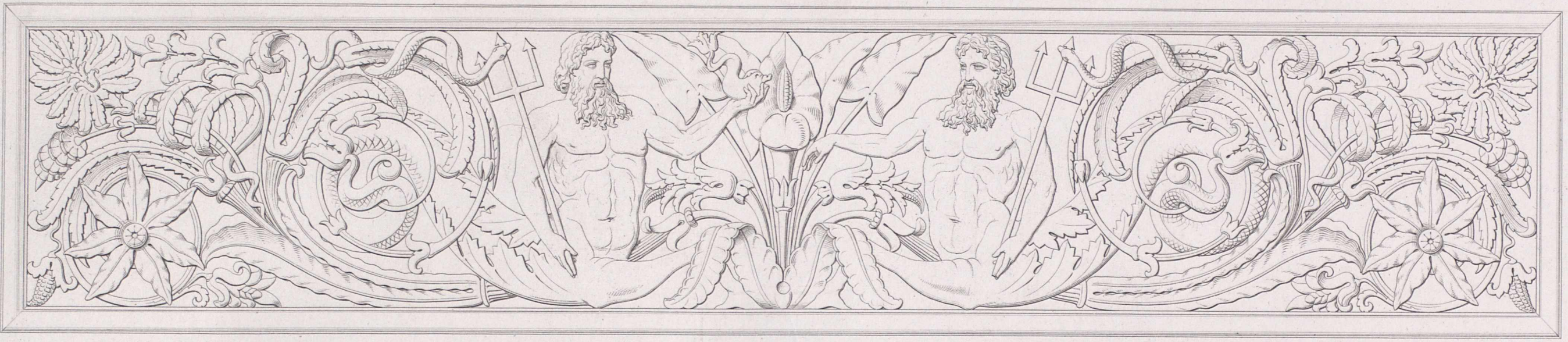

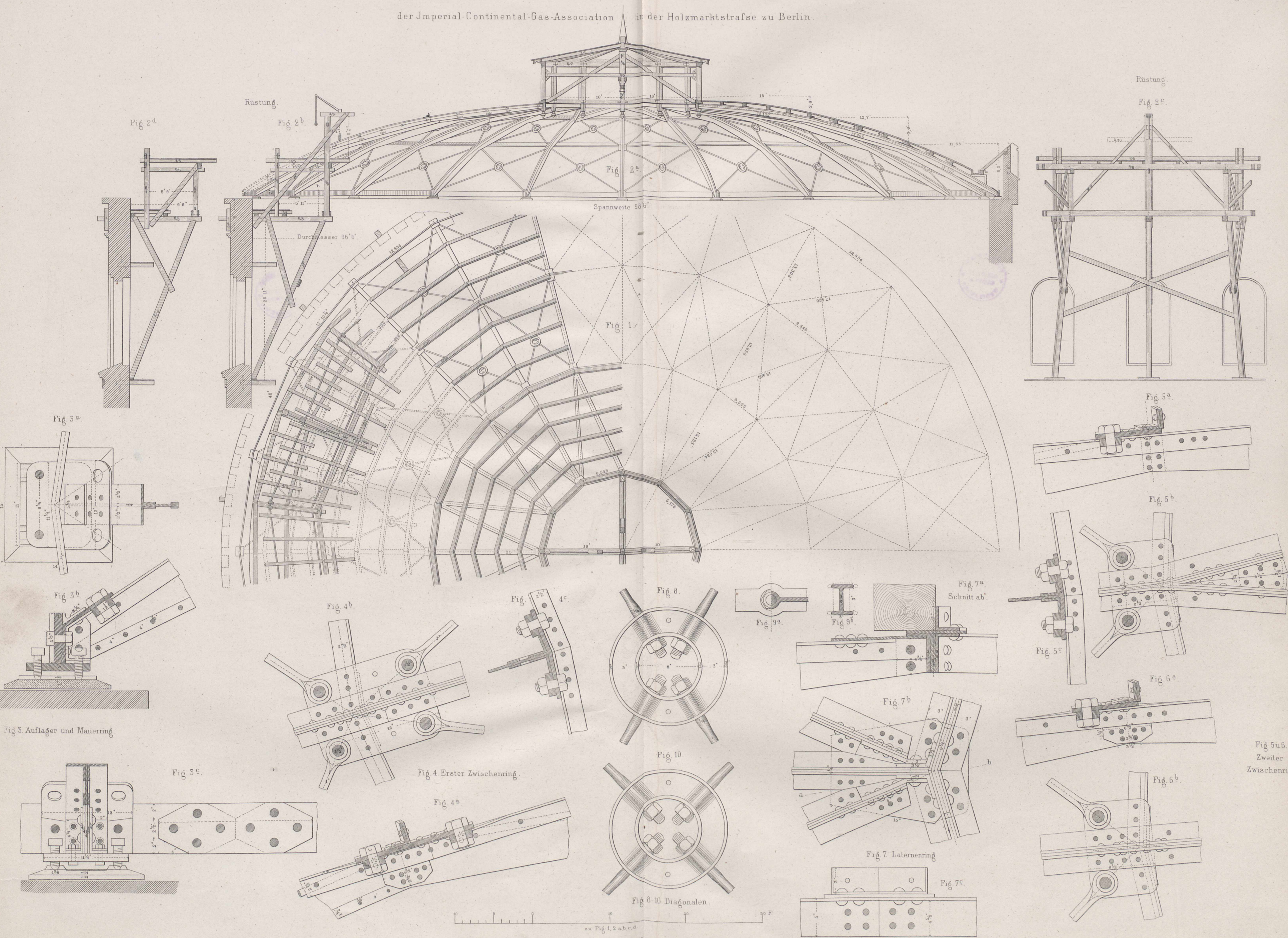

Fig. 3. Aufläger und Mauerring.

Fig. 3c.

Fig. 4 Erster Zwischenring.

Fig. 4a.

Fig. 8-10 Diagonalen.

zu Fig. 1, 2 a, b, c, d.

zu den Details

Rüstung

Fig. 2c.

Fig. 5a.

Fig. 5b.

Fig. 5c.

Fig. 6a.

Fig. 6b.

Fig. 5u.b.  
Zweiter  
Zwischenring.

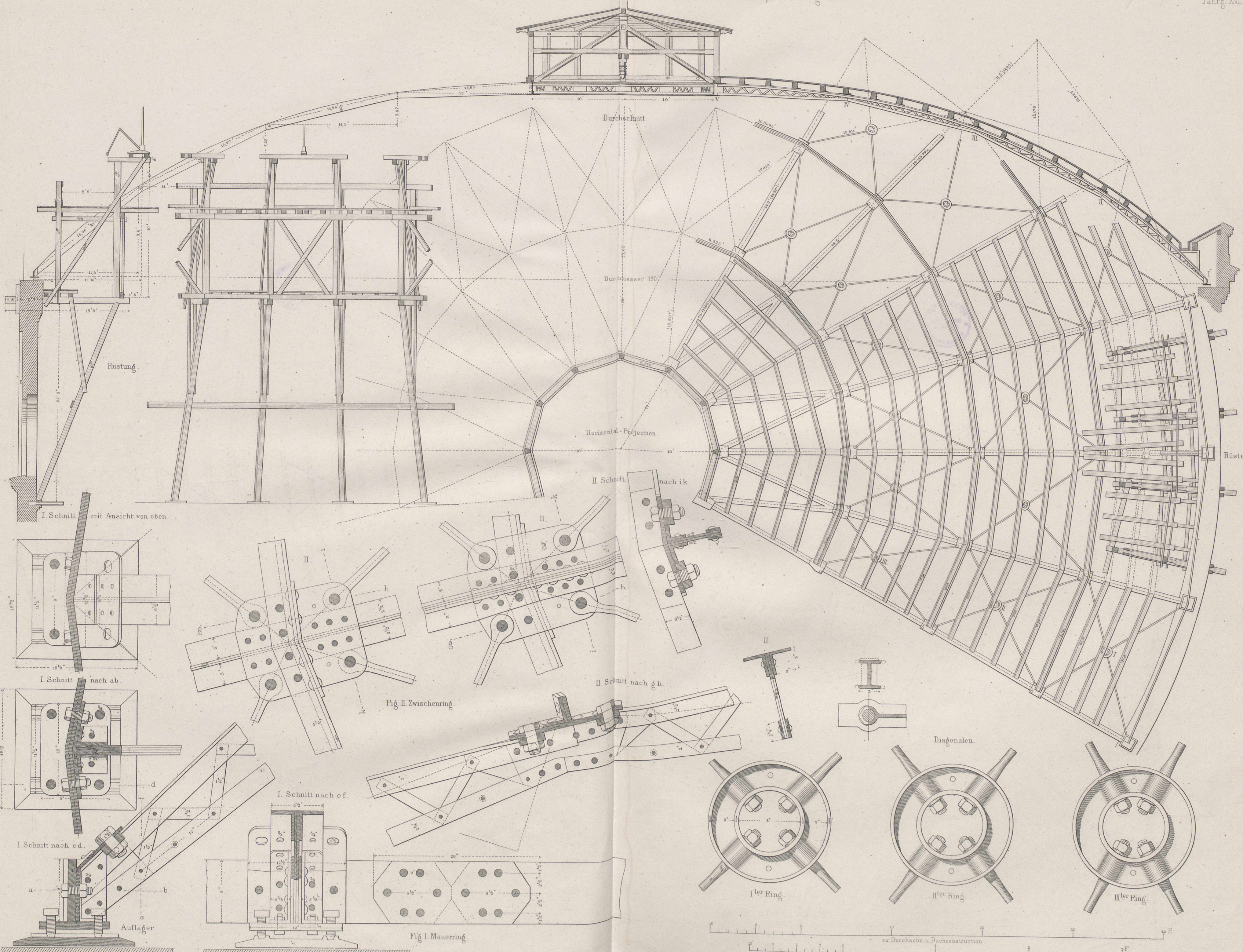

Hellweg N° 9 in Berlin.

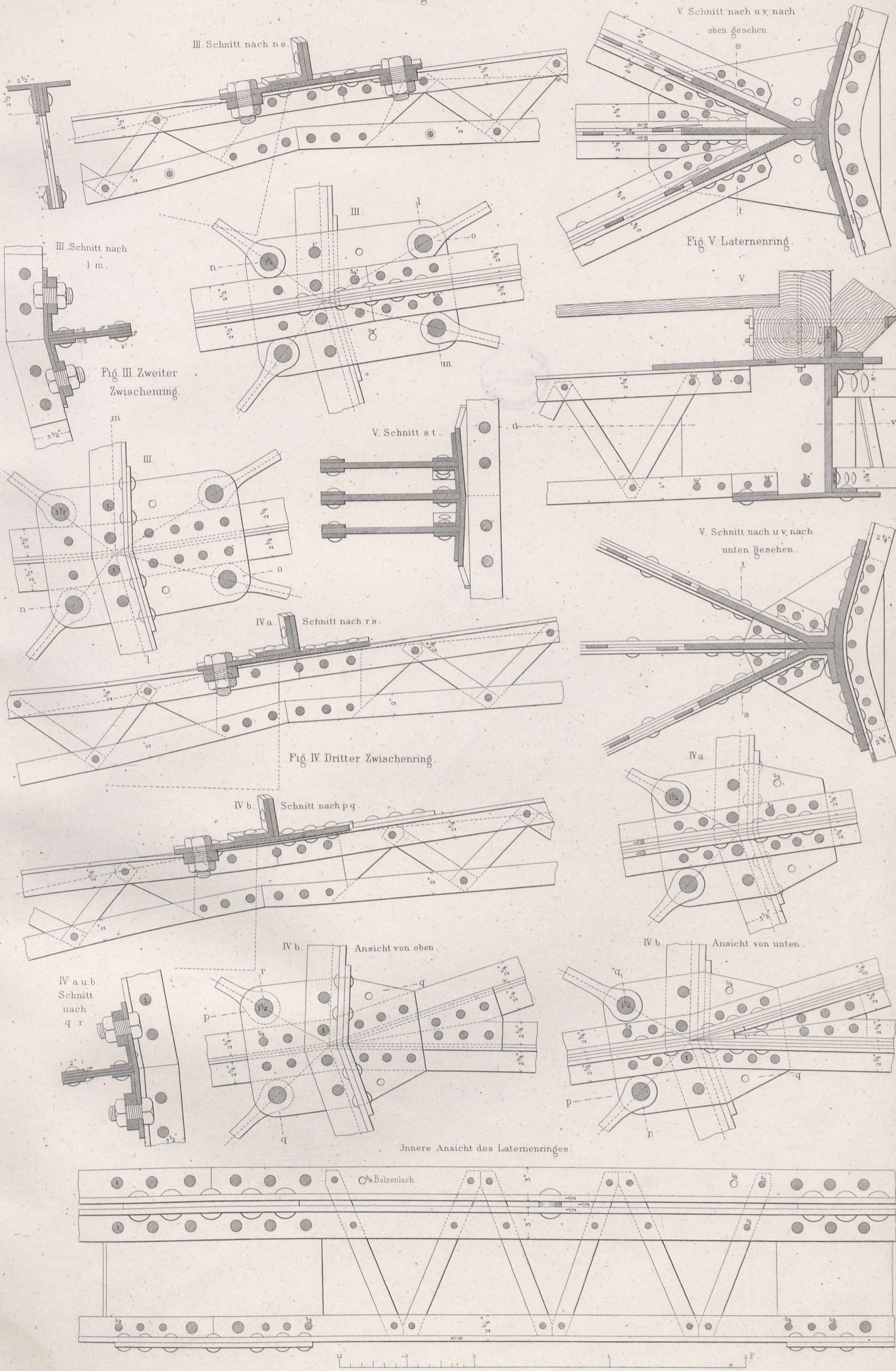

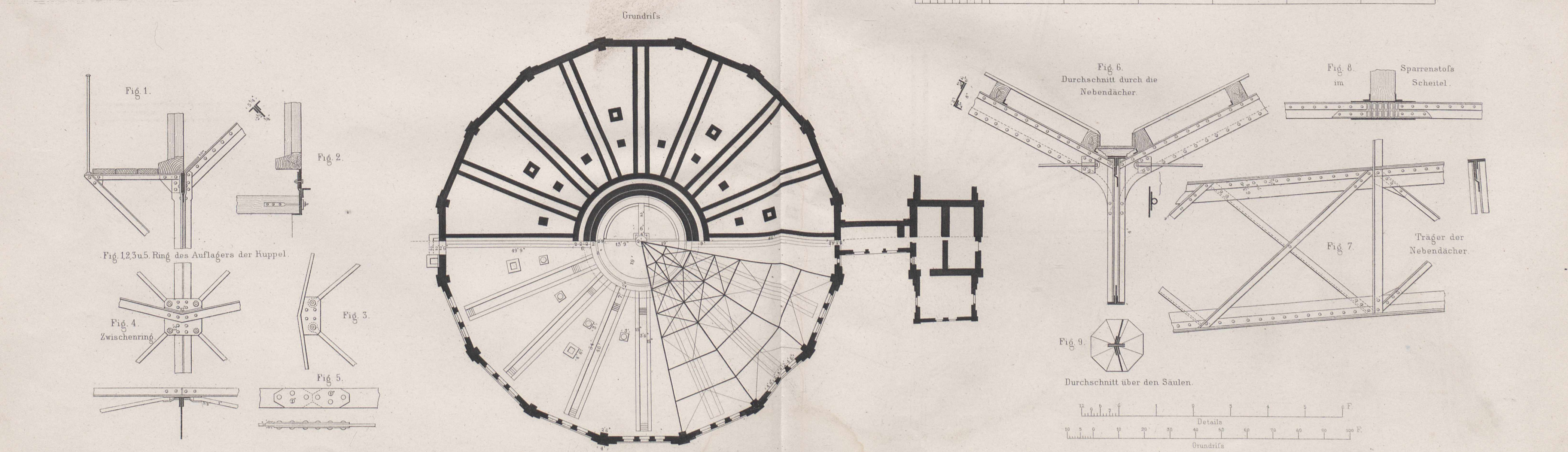
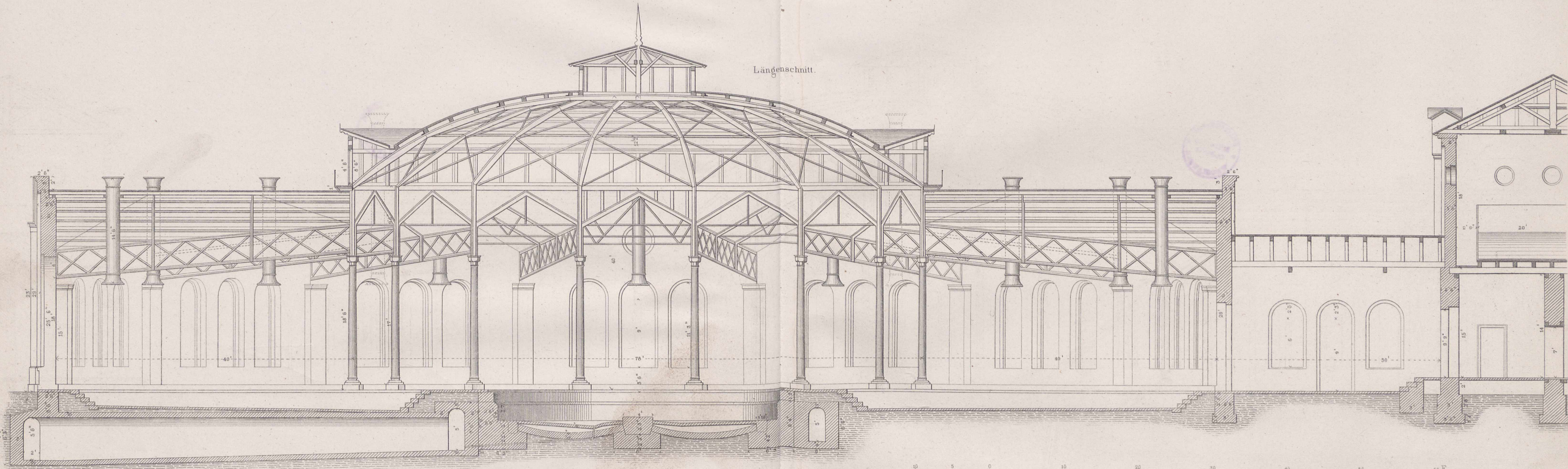
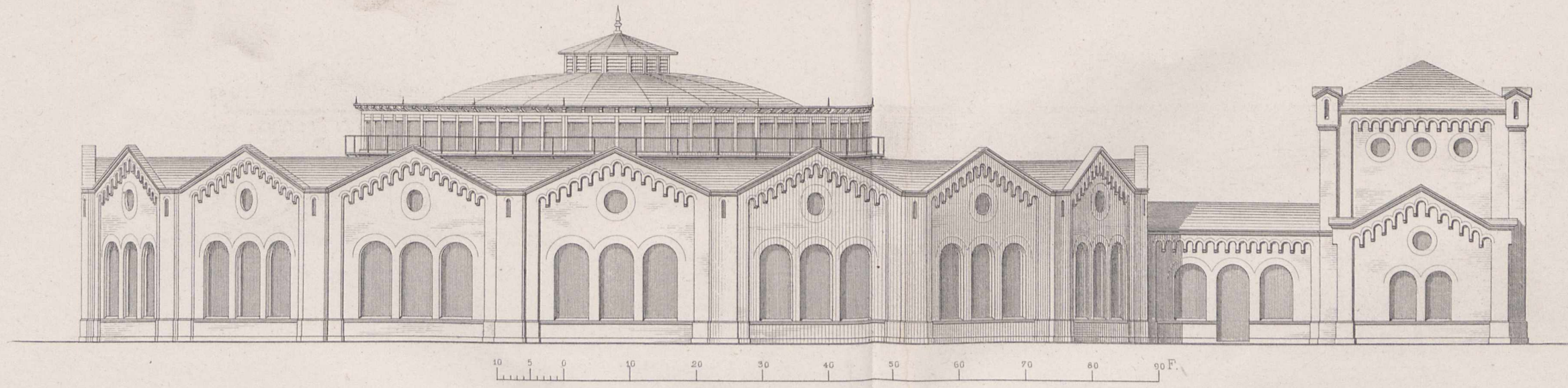



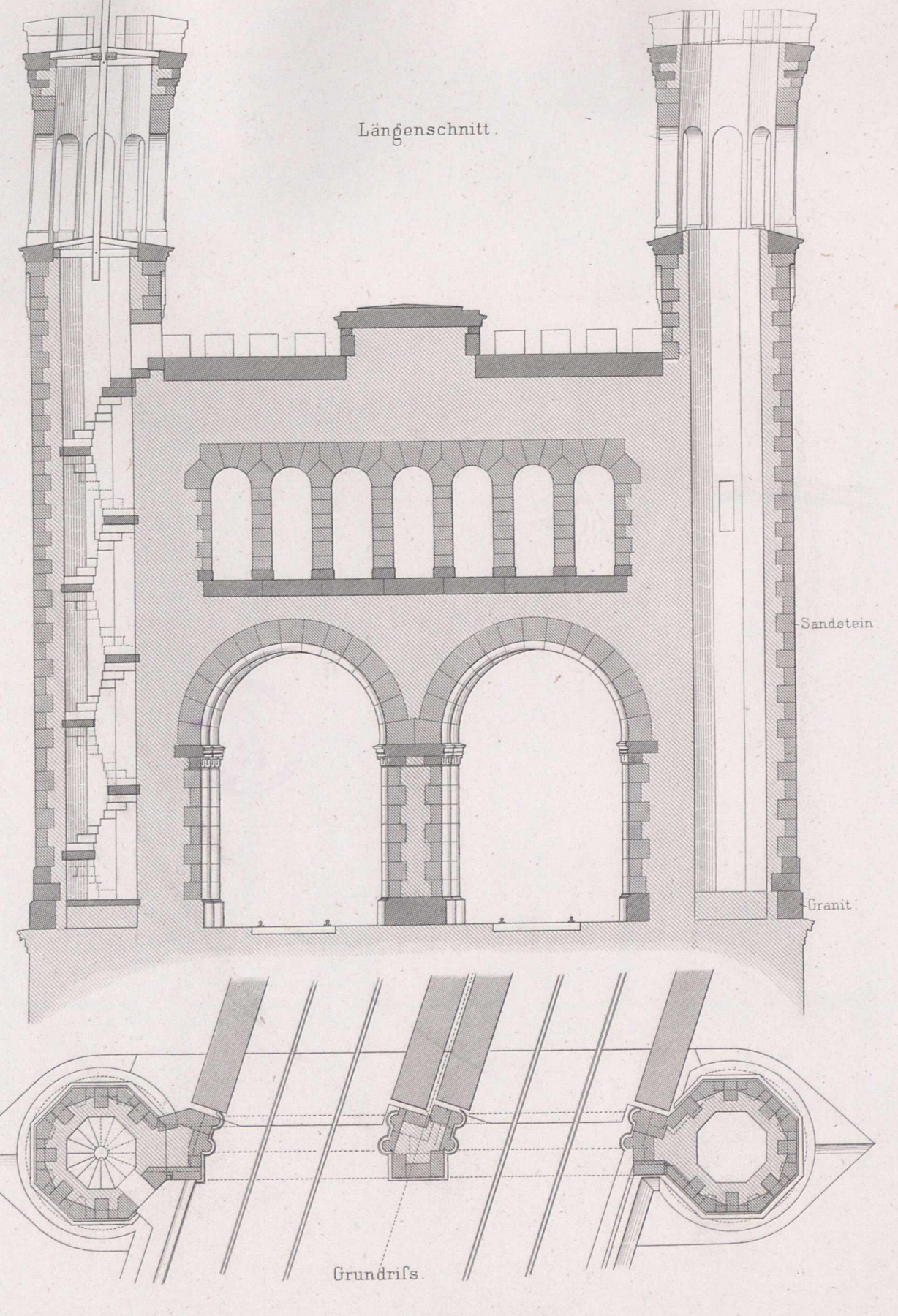
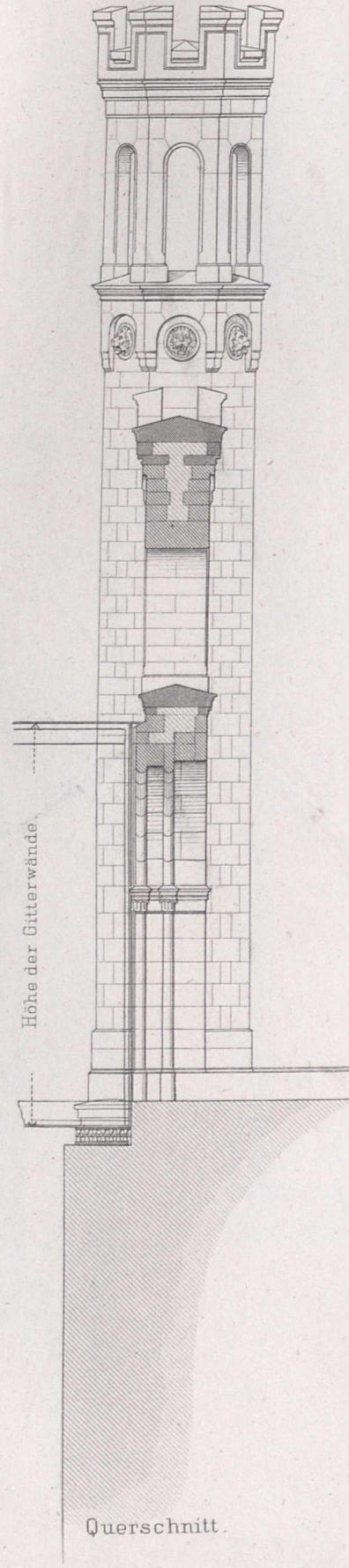
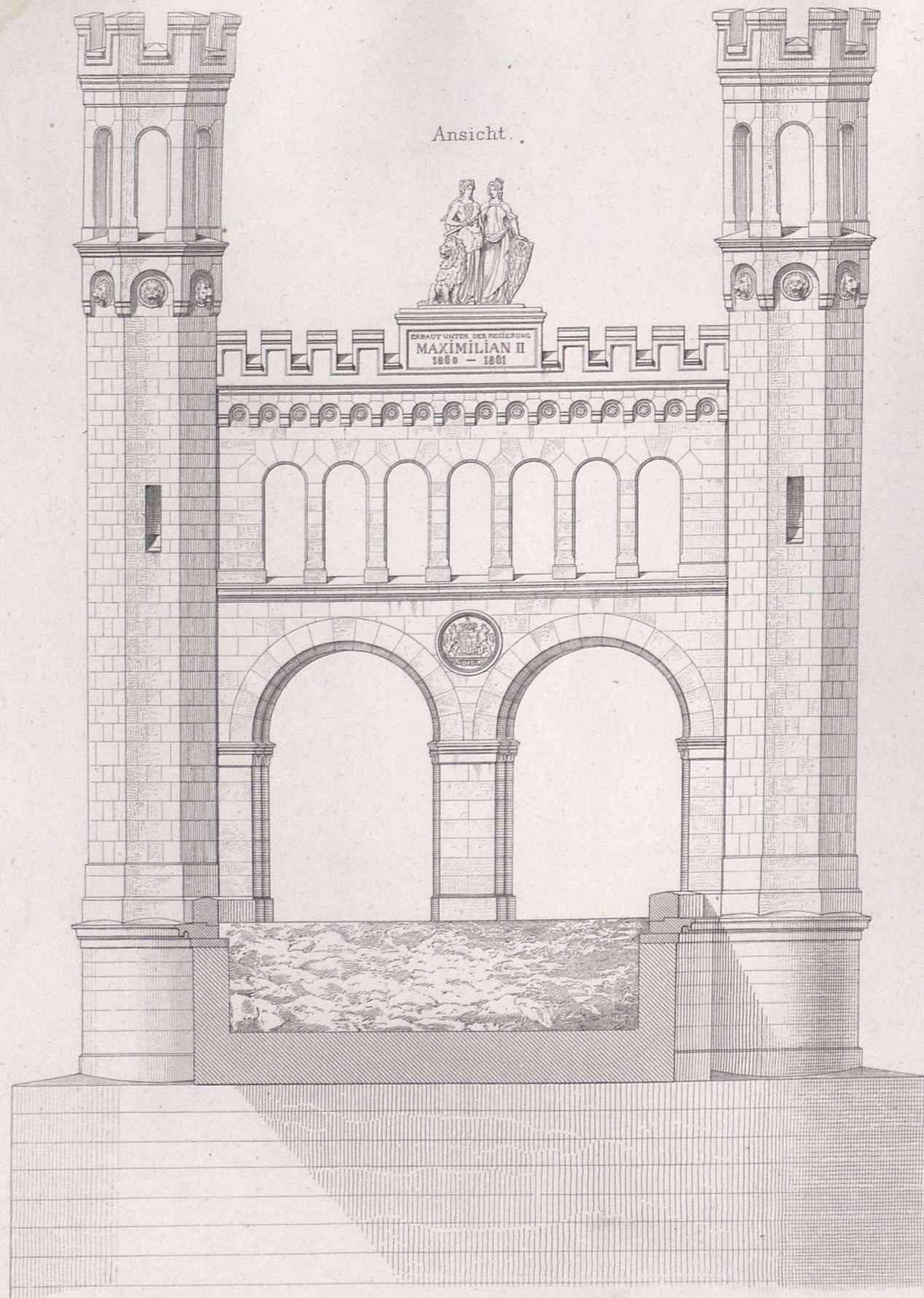

10 5 0 10 20 30 40 50 F. bayr.



Durchlässe von 4 und 6 Fuß lichter Weite.

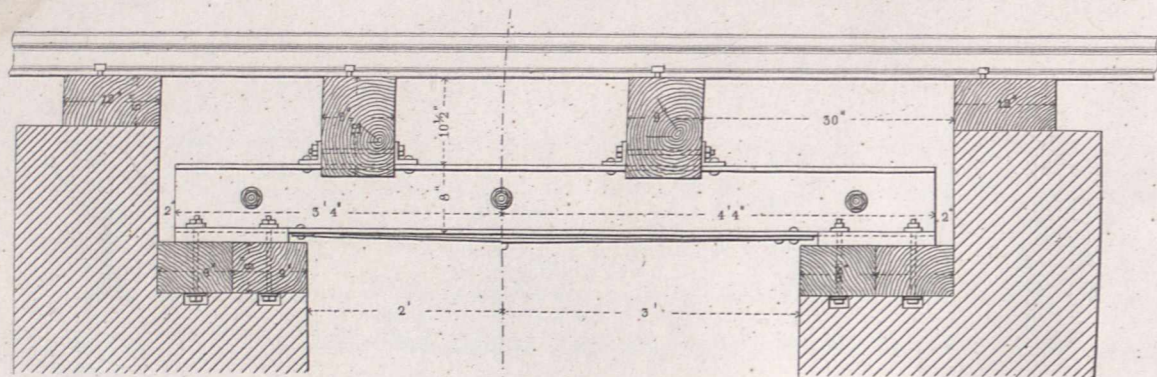

Brücke von 8 Fuß lichter Weite.

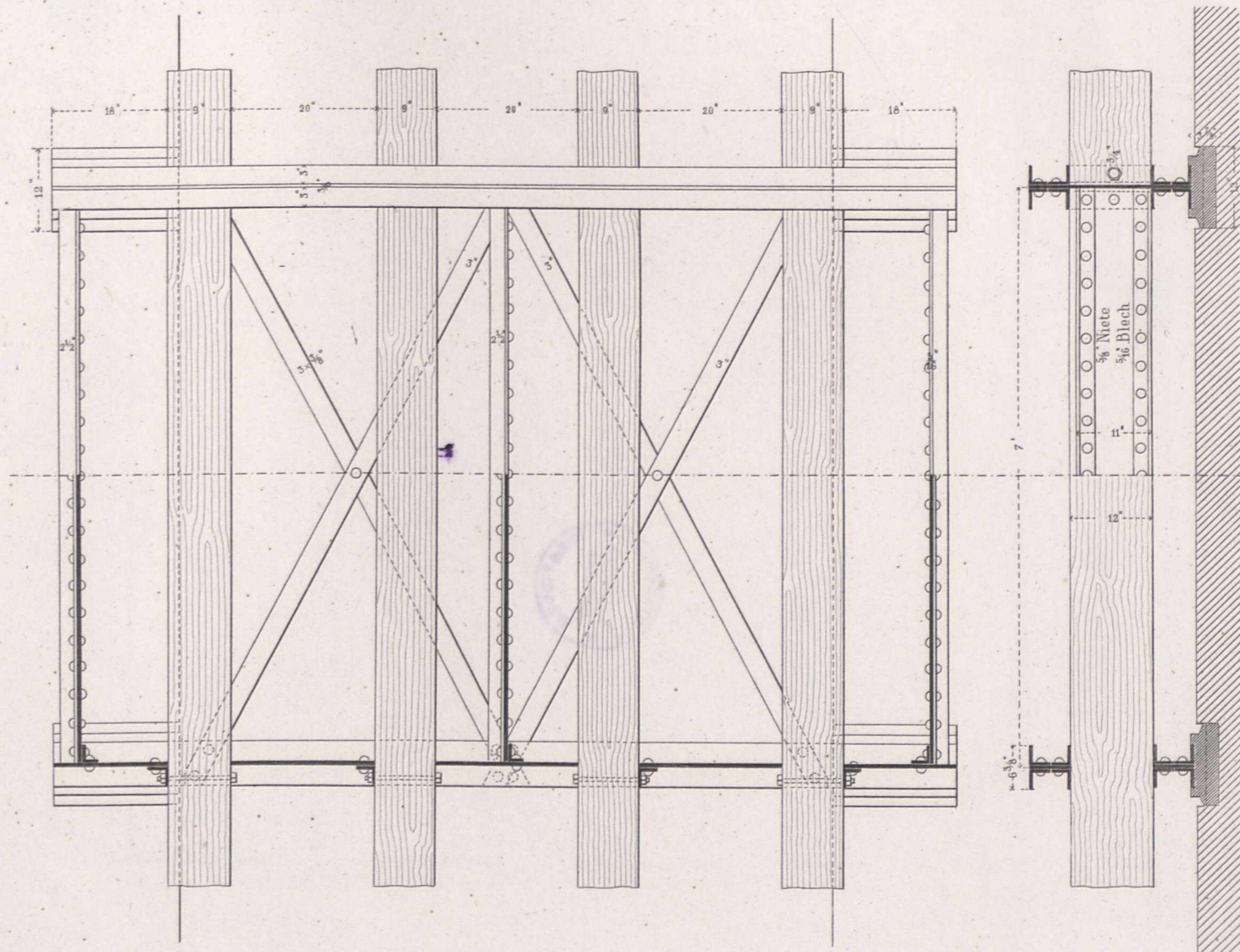
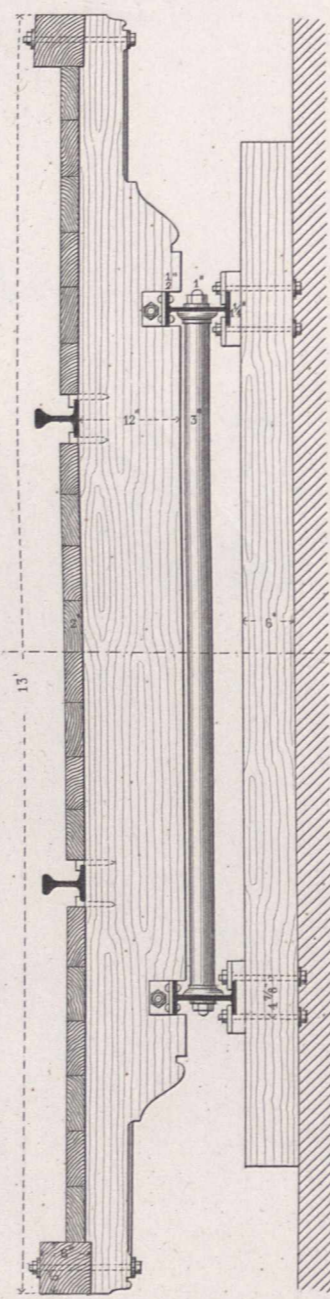
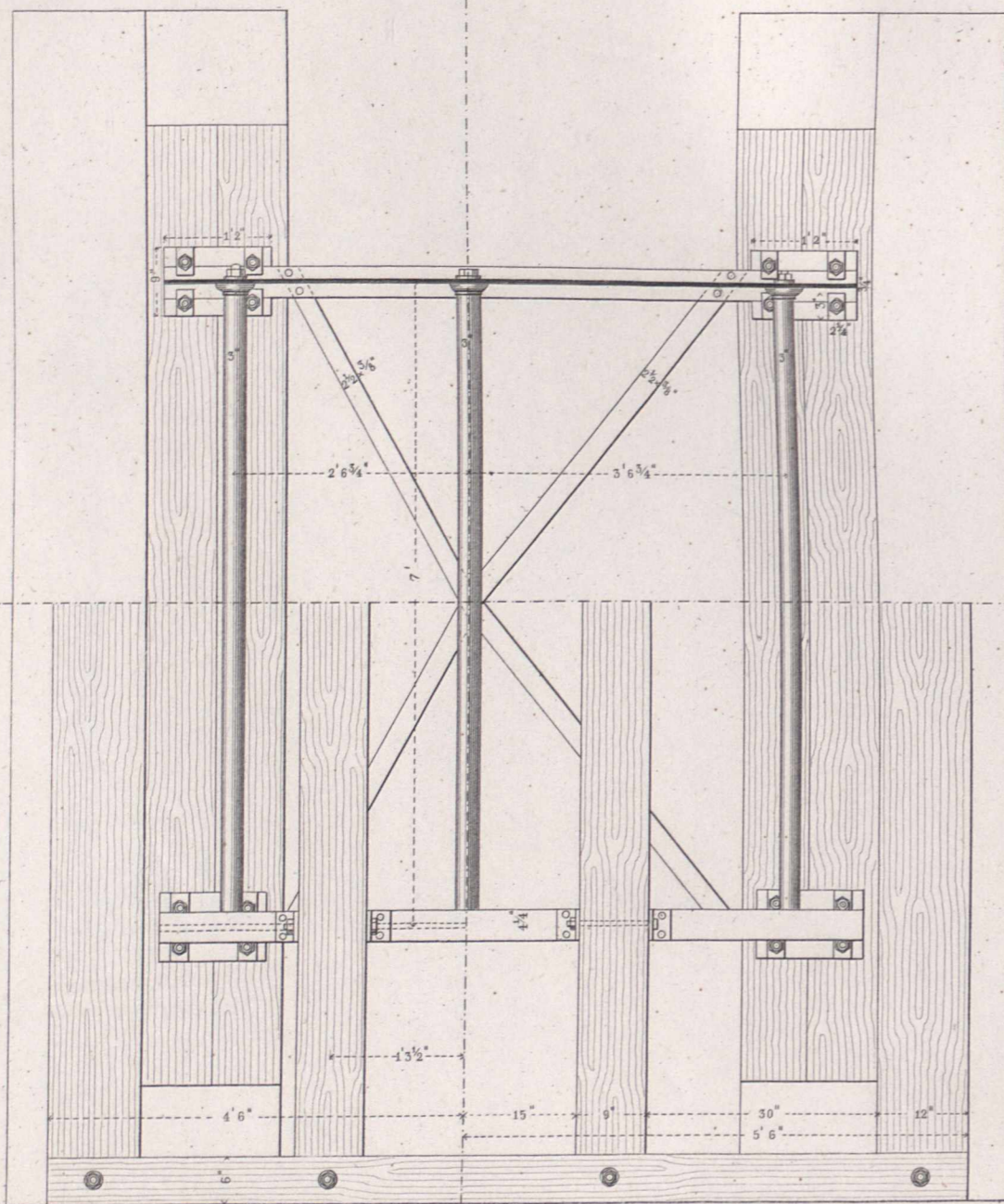
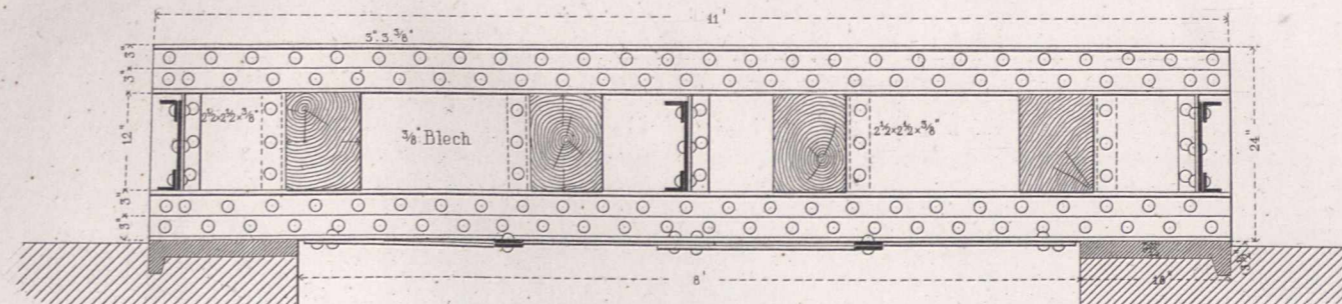

Schiefe Brücke von 10 Fuß lichter Weite

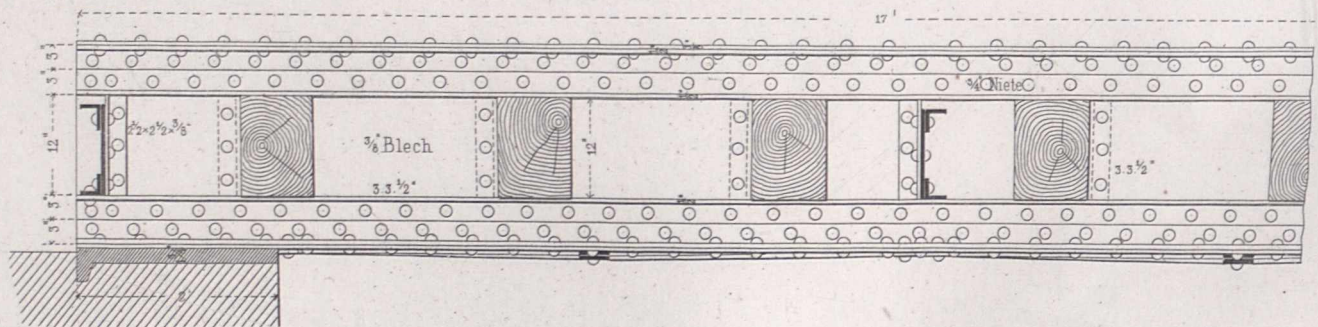

Brücke von 12 Fuß lichter Weite

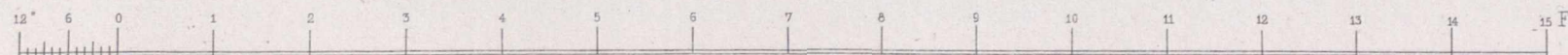
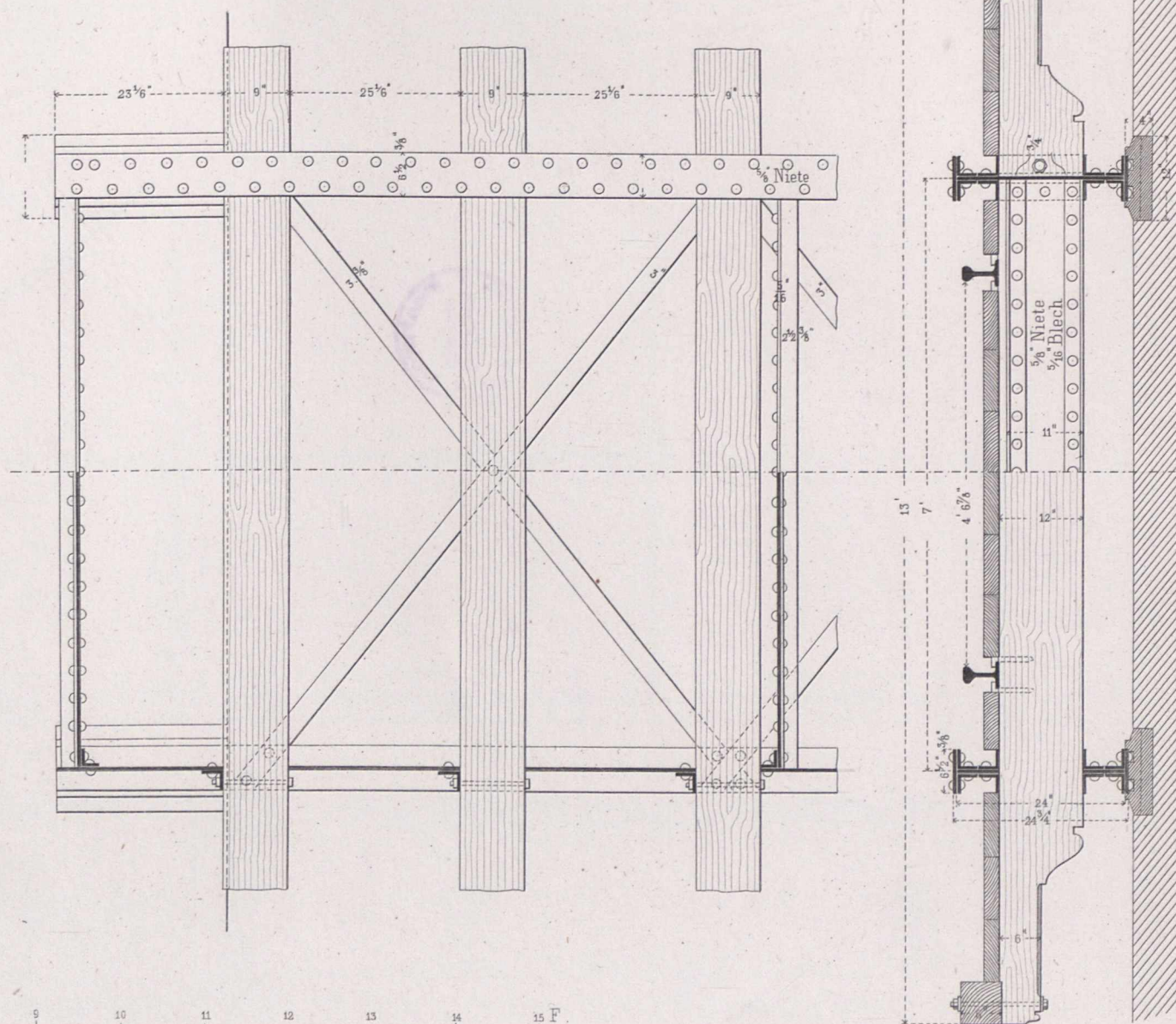
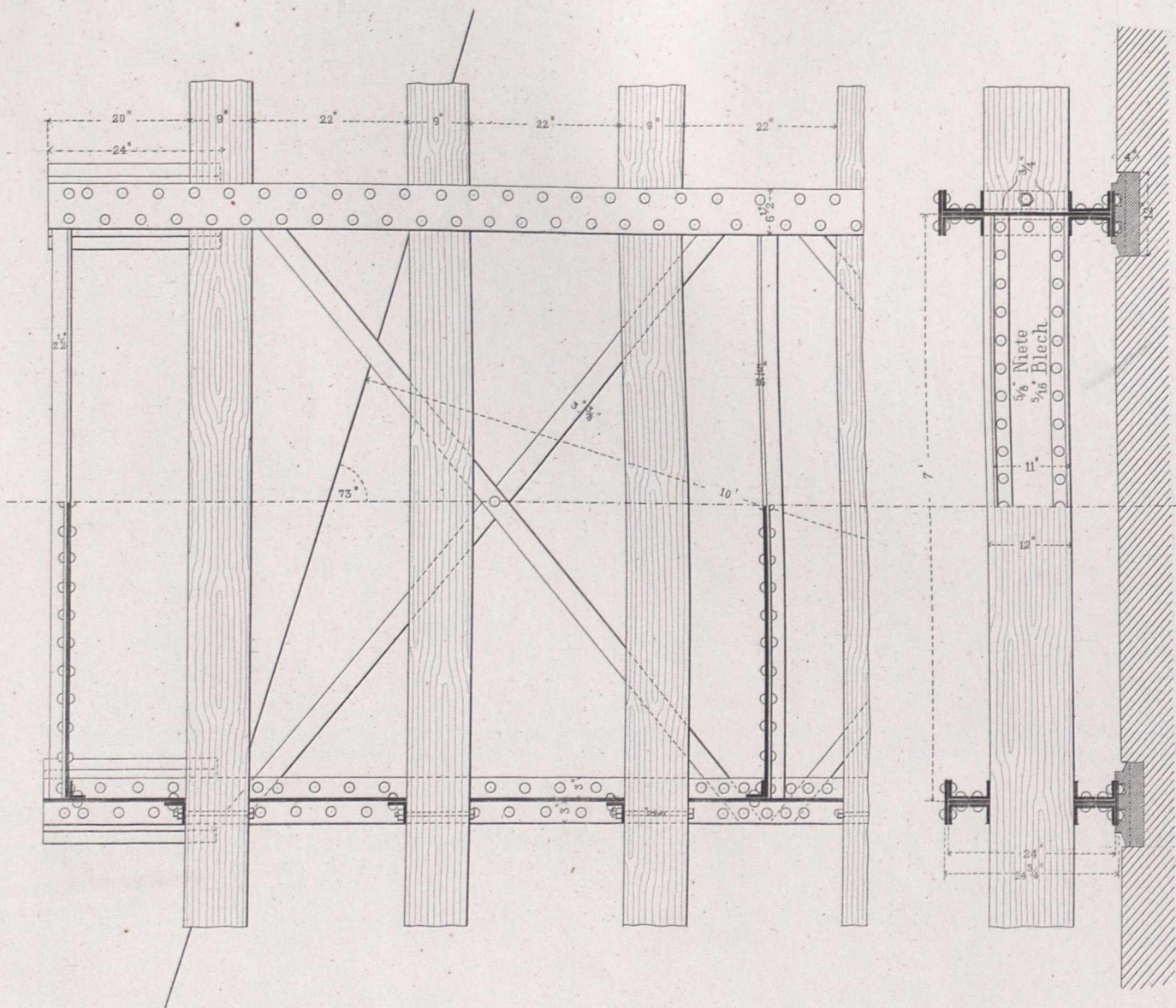
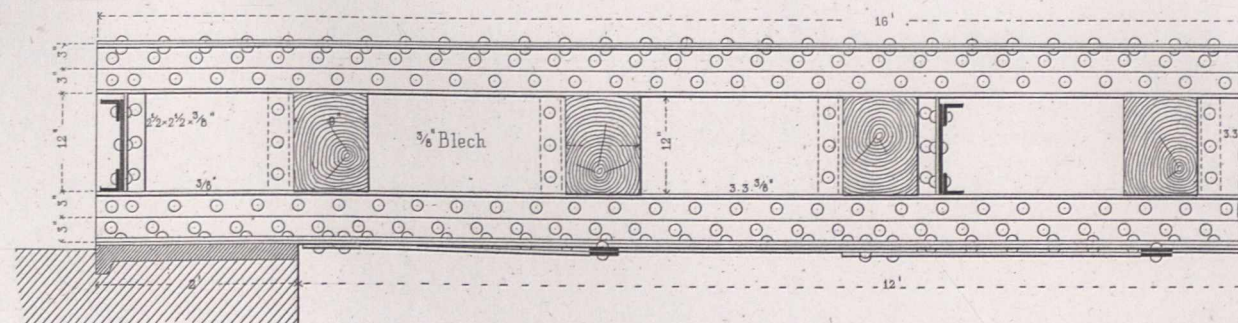

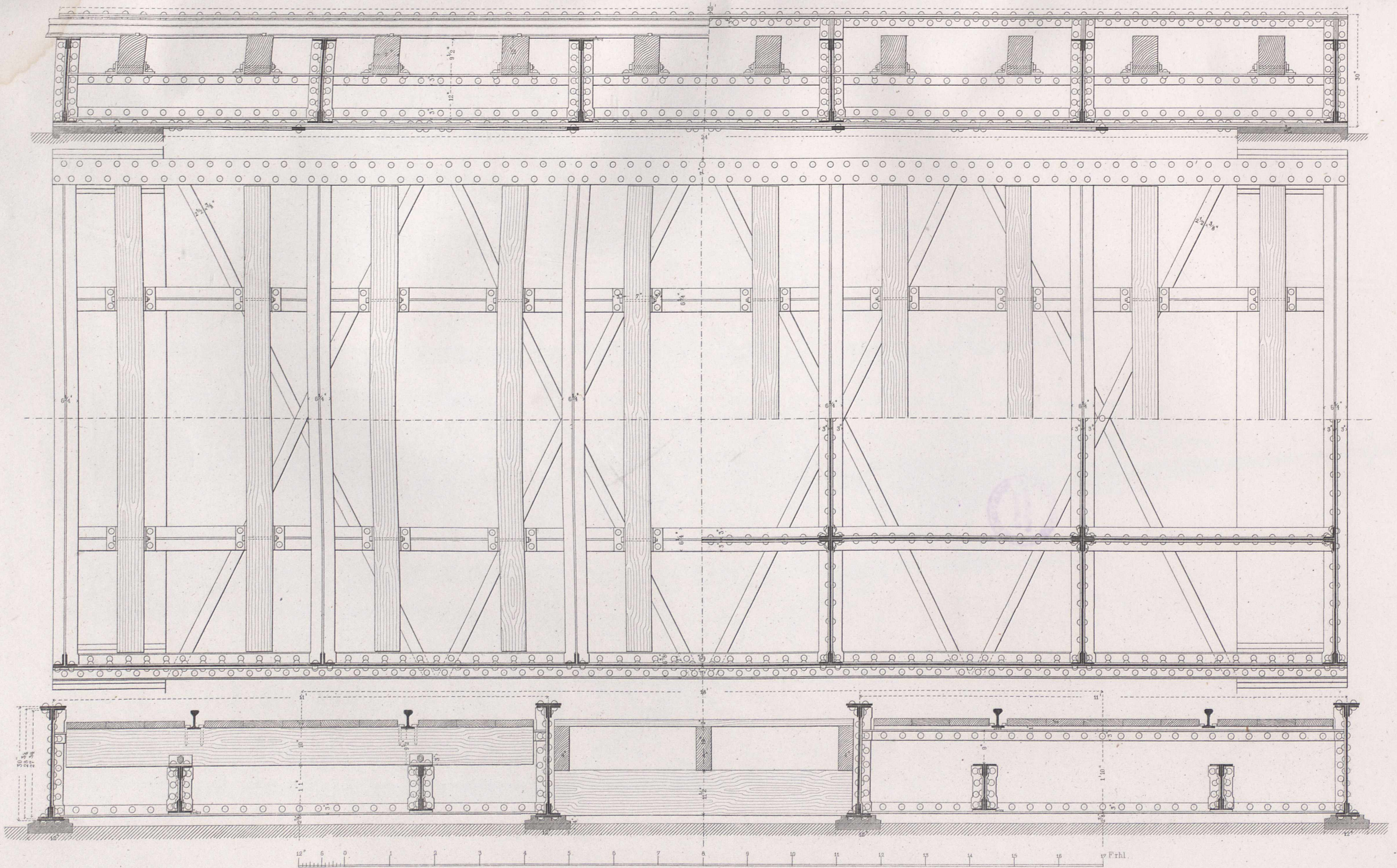

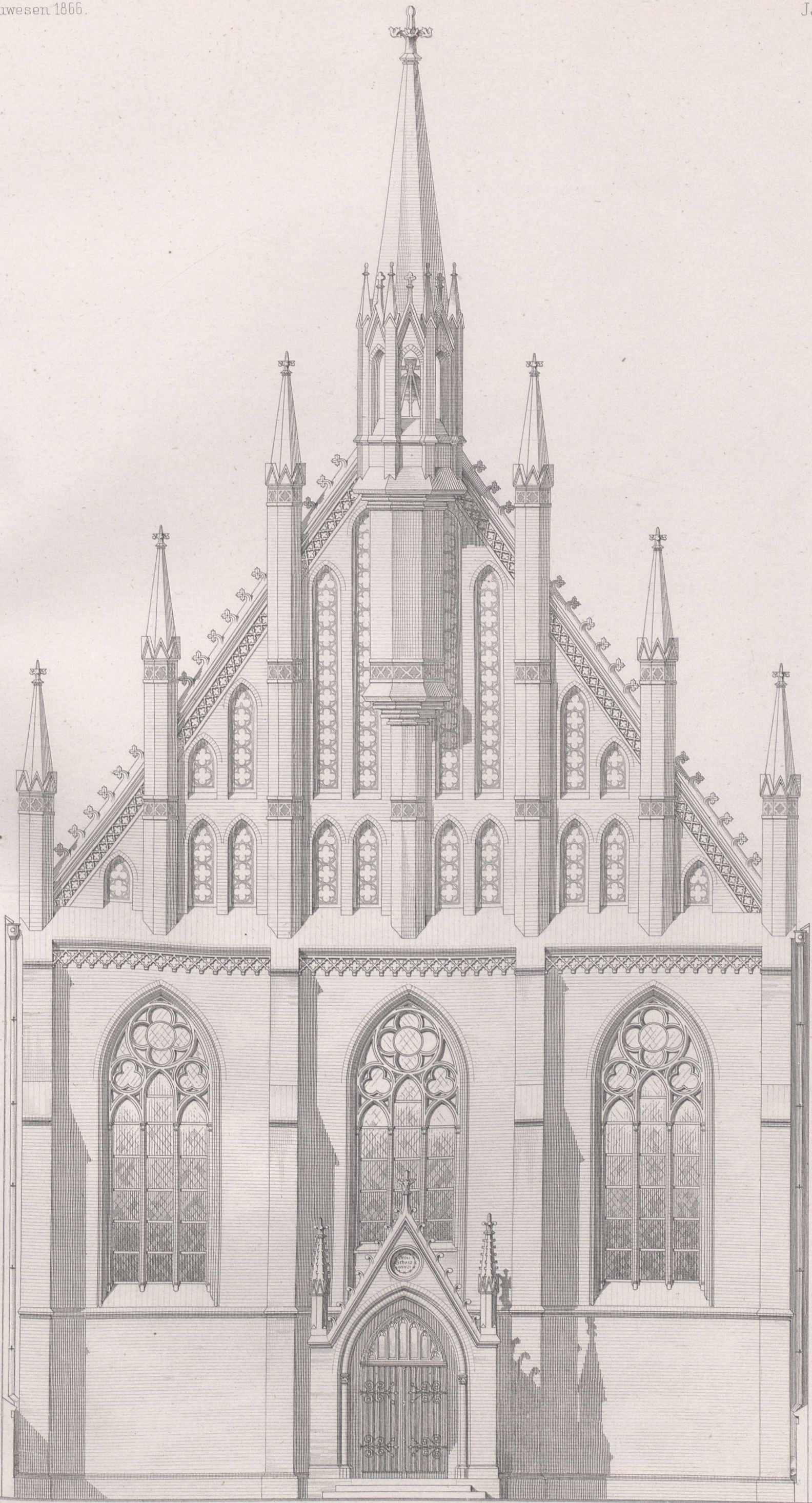

Christus-Kirche in Berlin.

10 5 0 10 20 30 F.

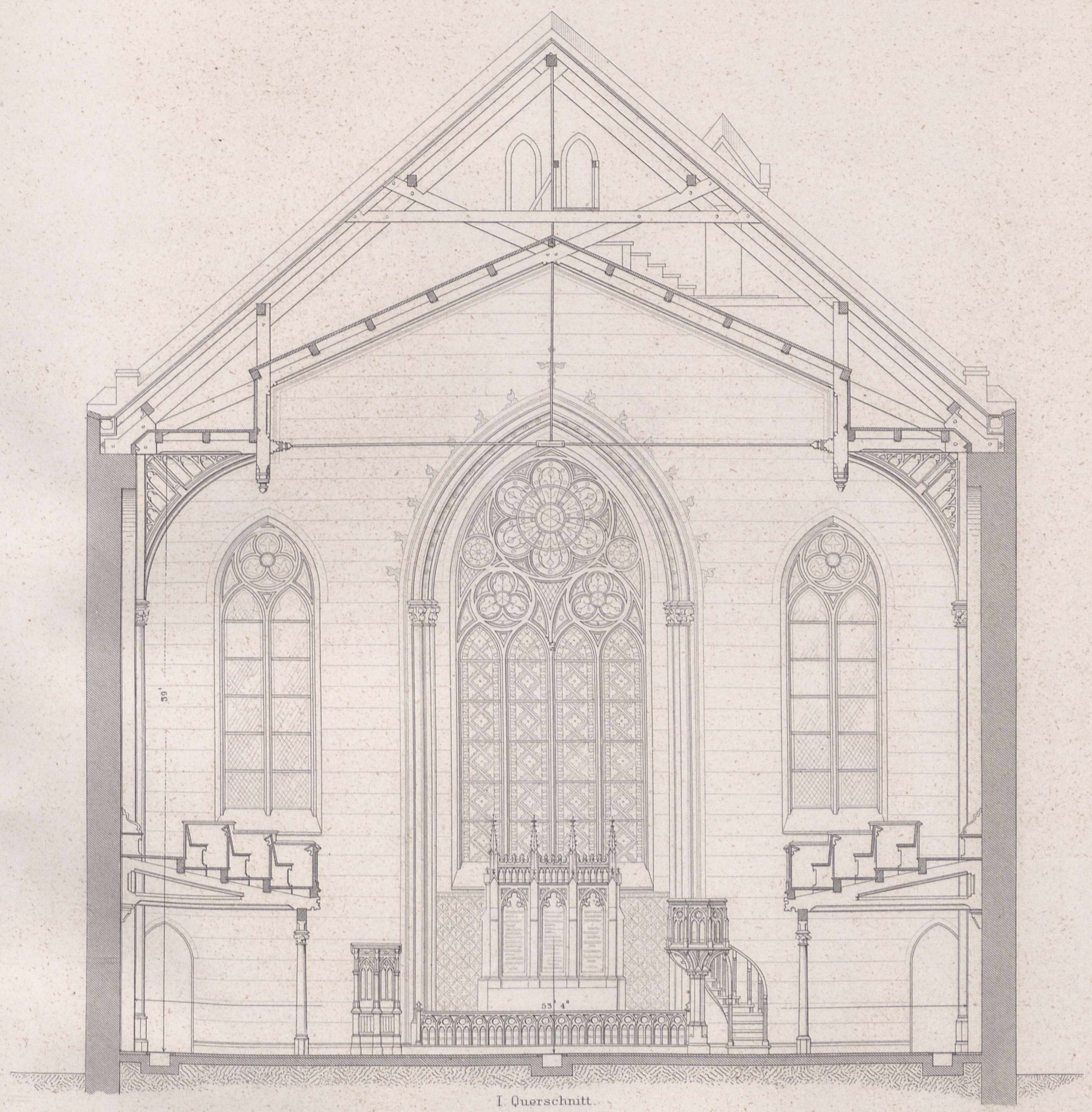

I. Querschnitt.

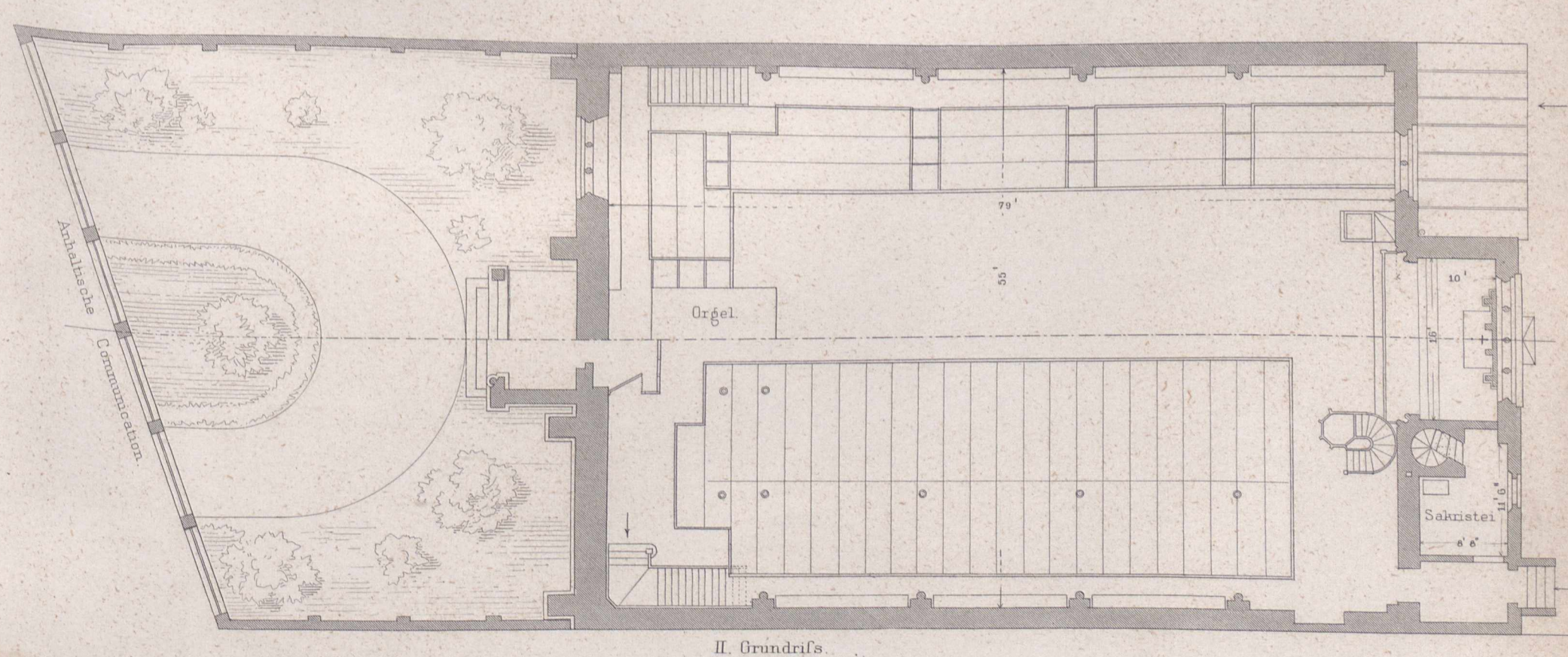

II. Grundriss.

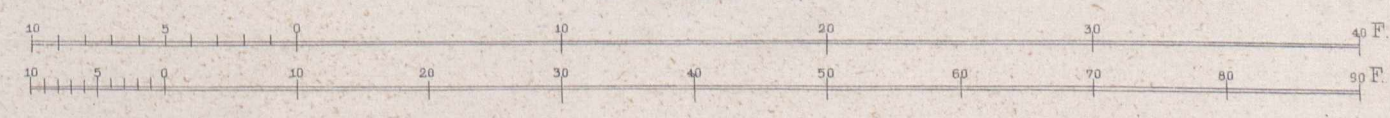

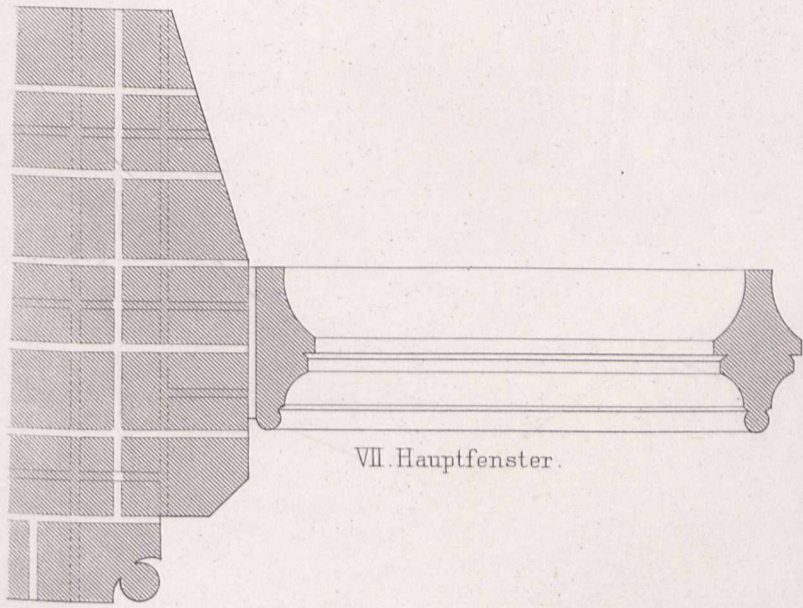

VII. Hauptfenster.

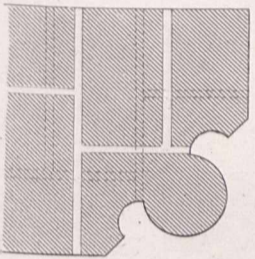
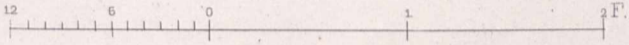

VIII. Hauptthür.

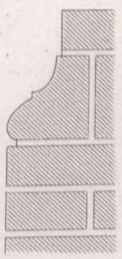

IX. Sockel.

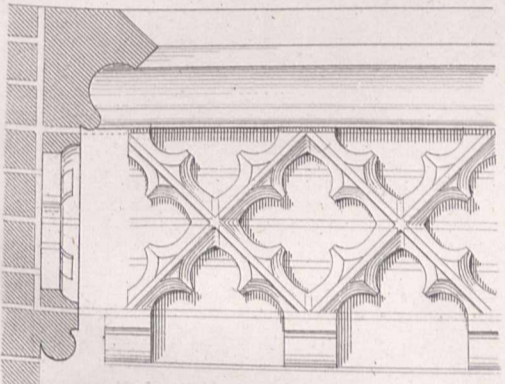

X. Gitter-Fries.

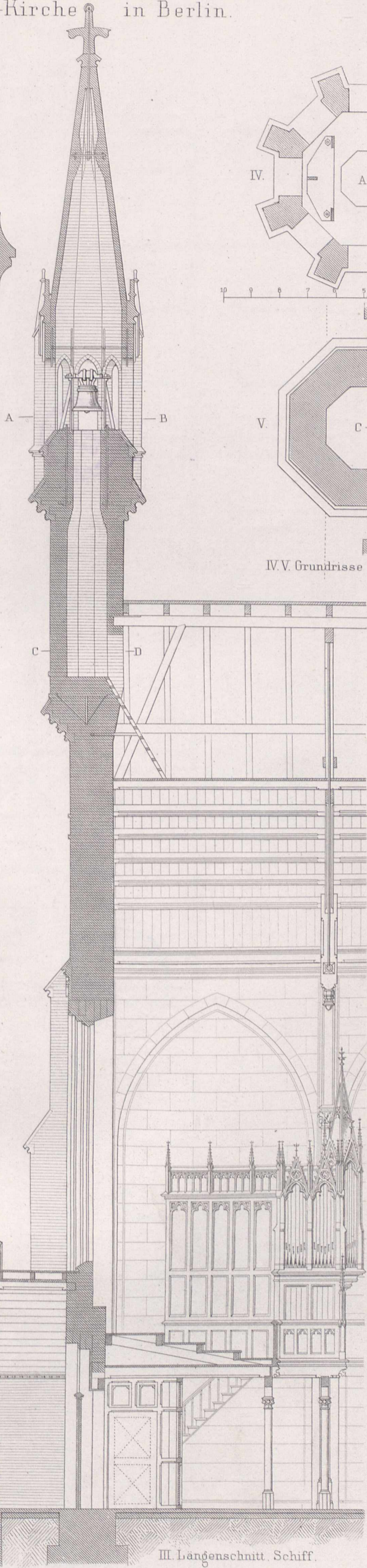

III. Längenschnitt. Schiff.

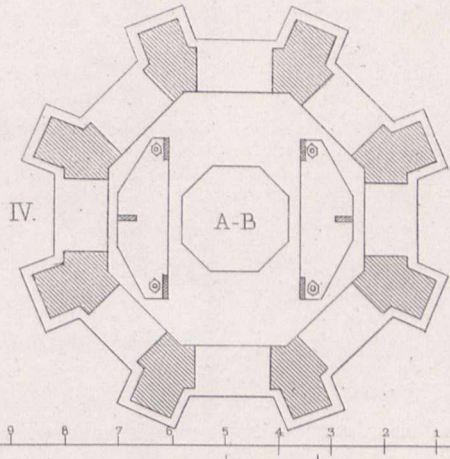

IV.

A-B

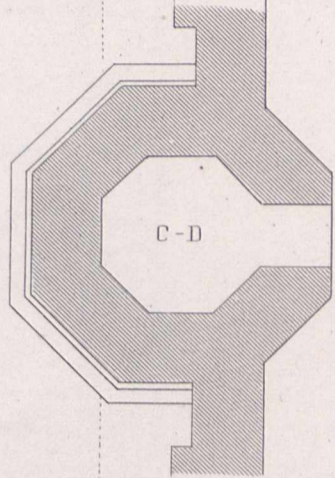
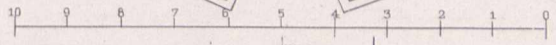

V.

C-D

IV.V. Grundrisse des Thürmchens.

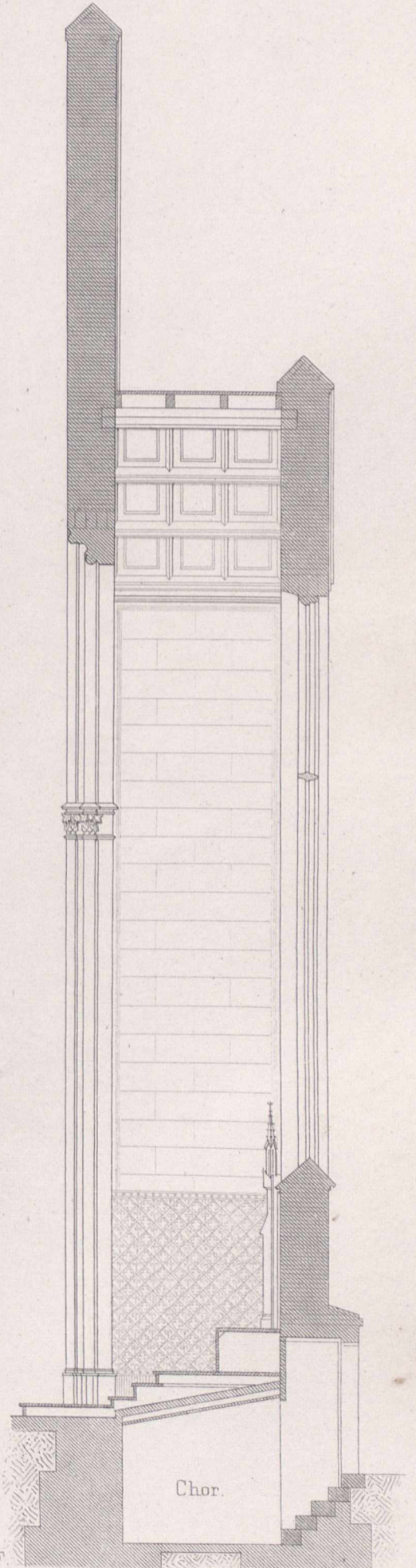

Chor.

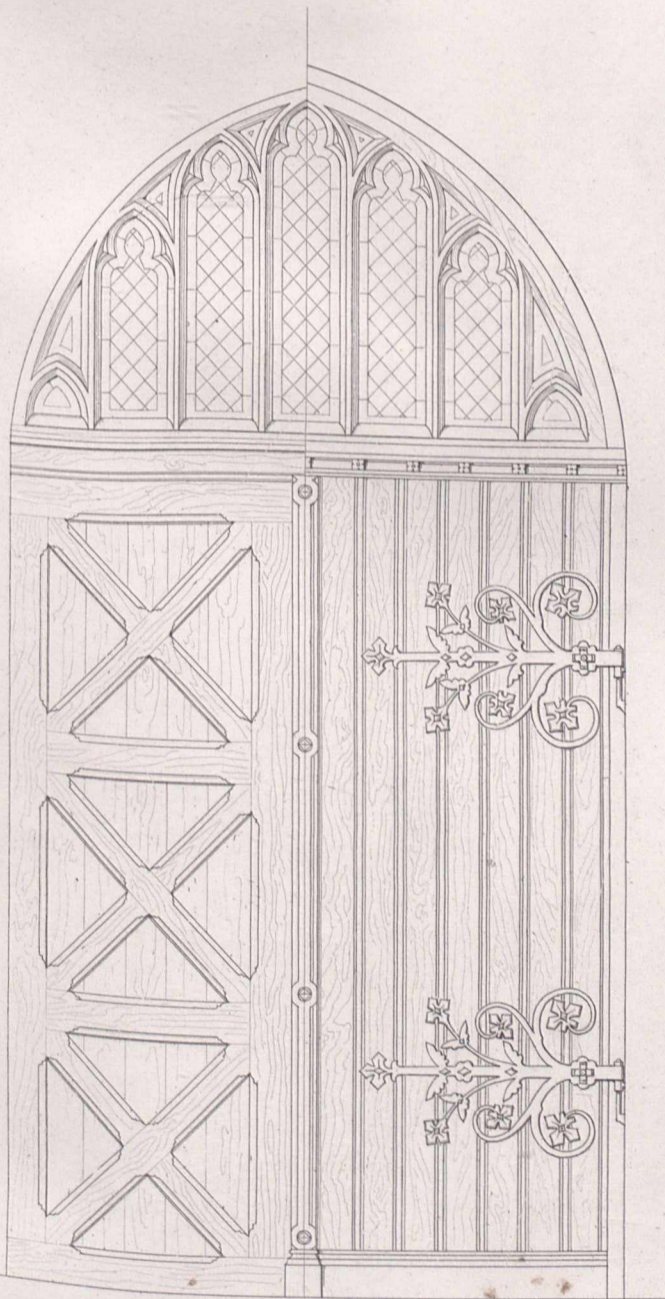

Jnnenseite.

Aussenseite.

VI. Hauptthür.

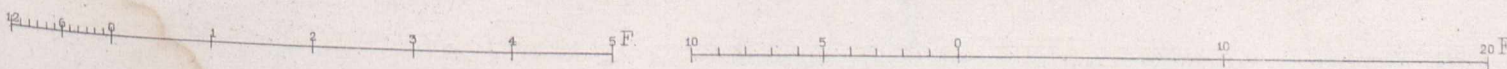

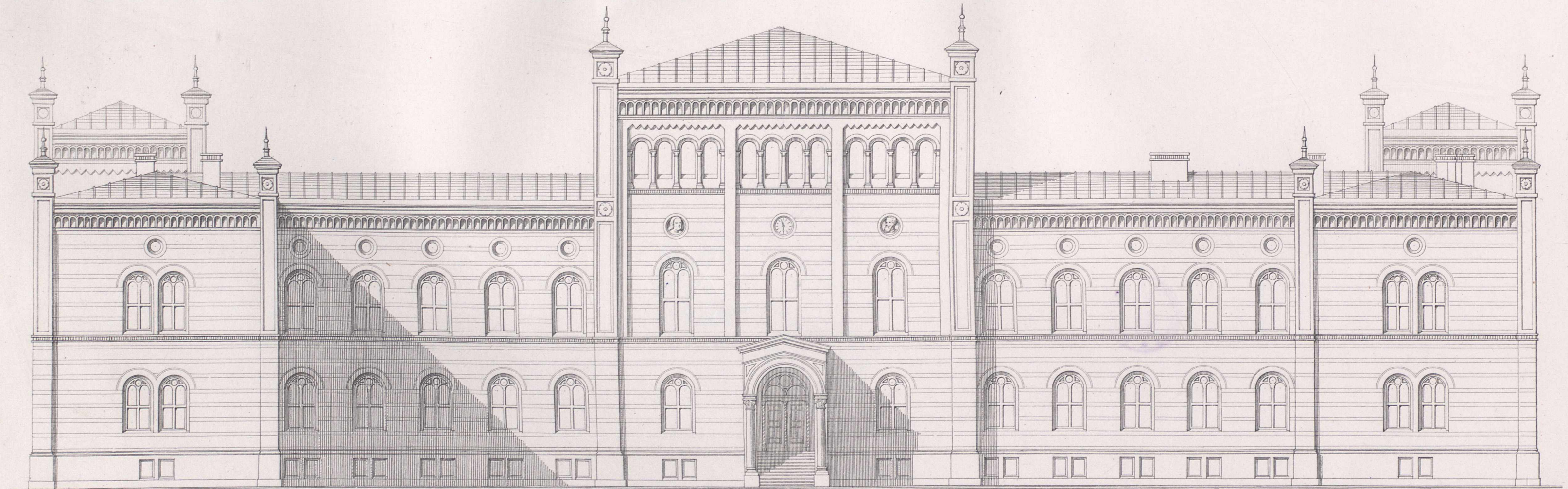

Vordere Ansicht.



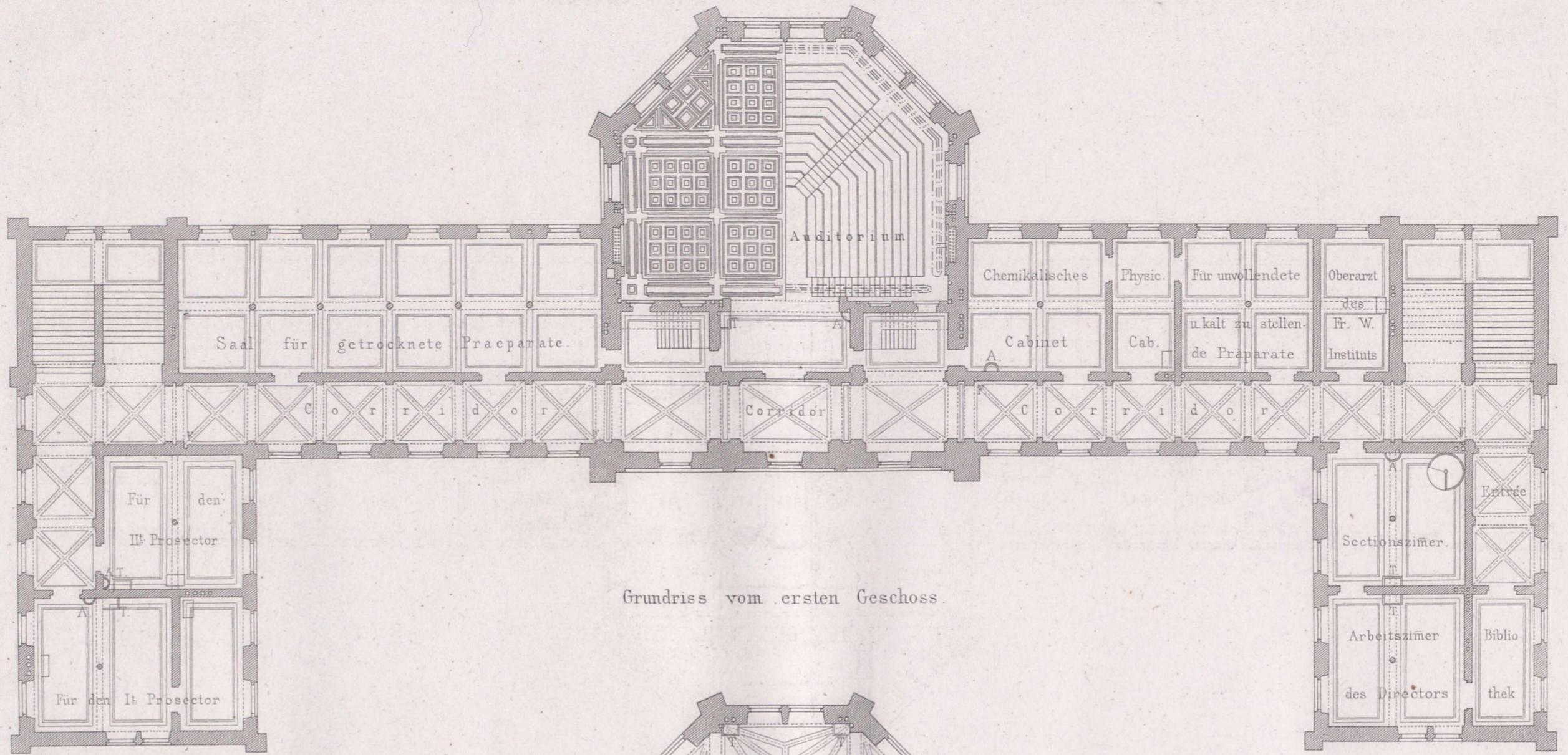

Grundriss vom ersten Geschoss

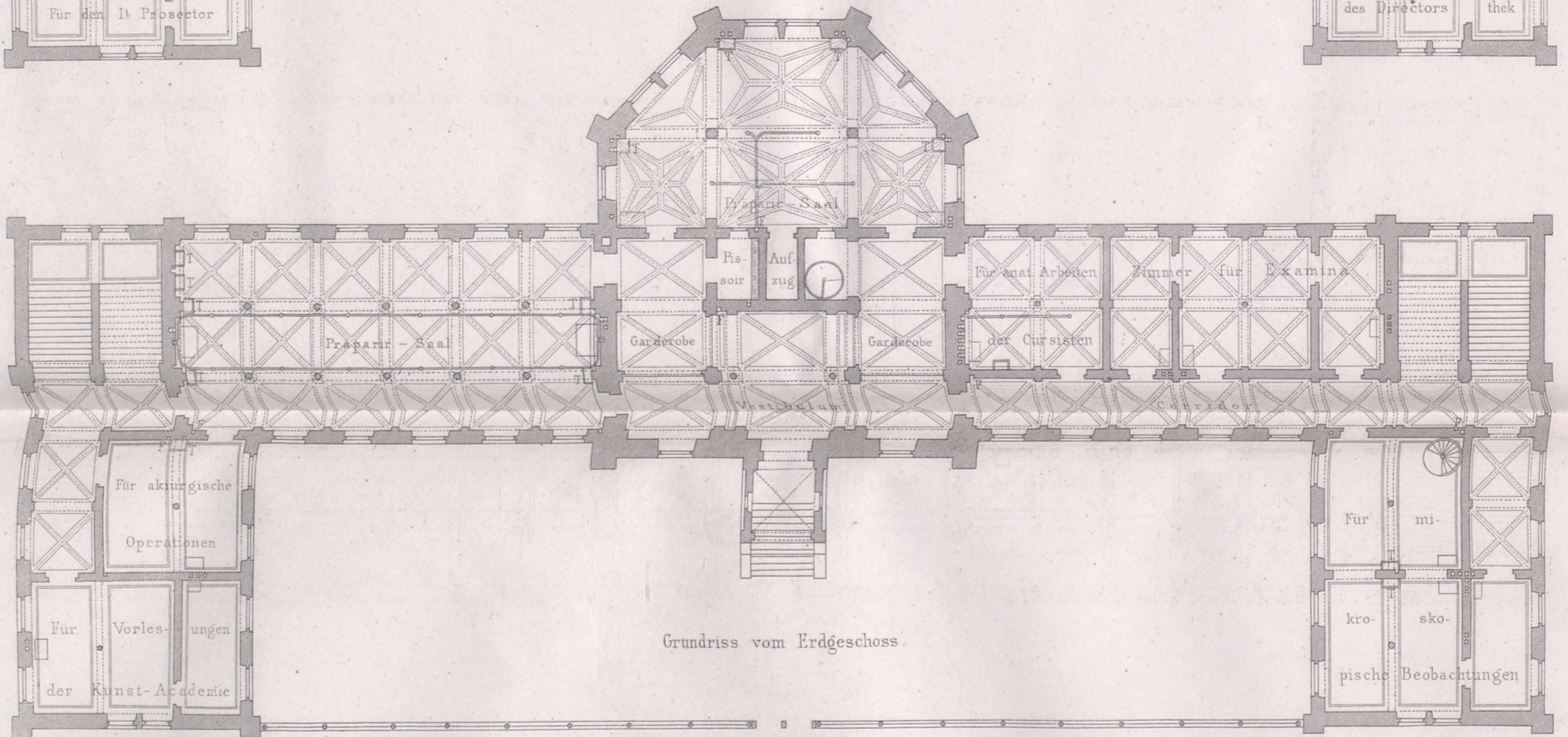

Grundriss vom Erdgeschoss

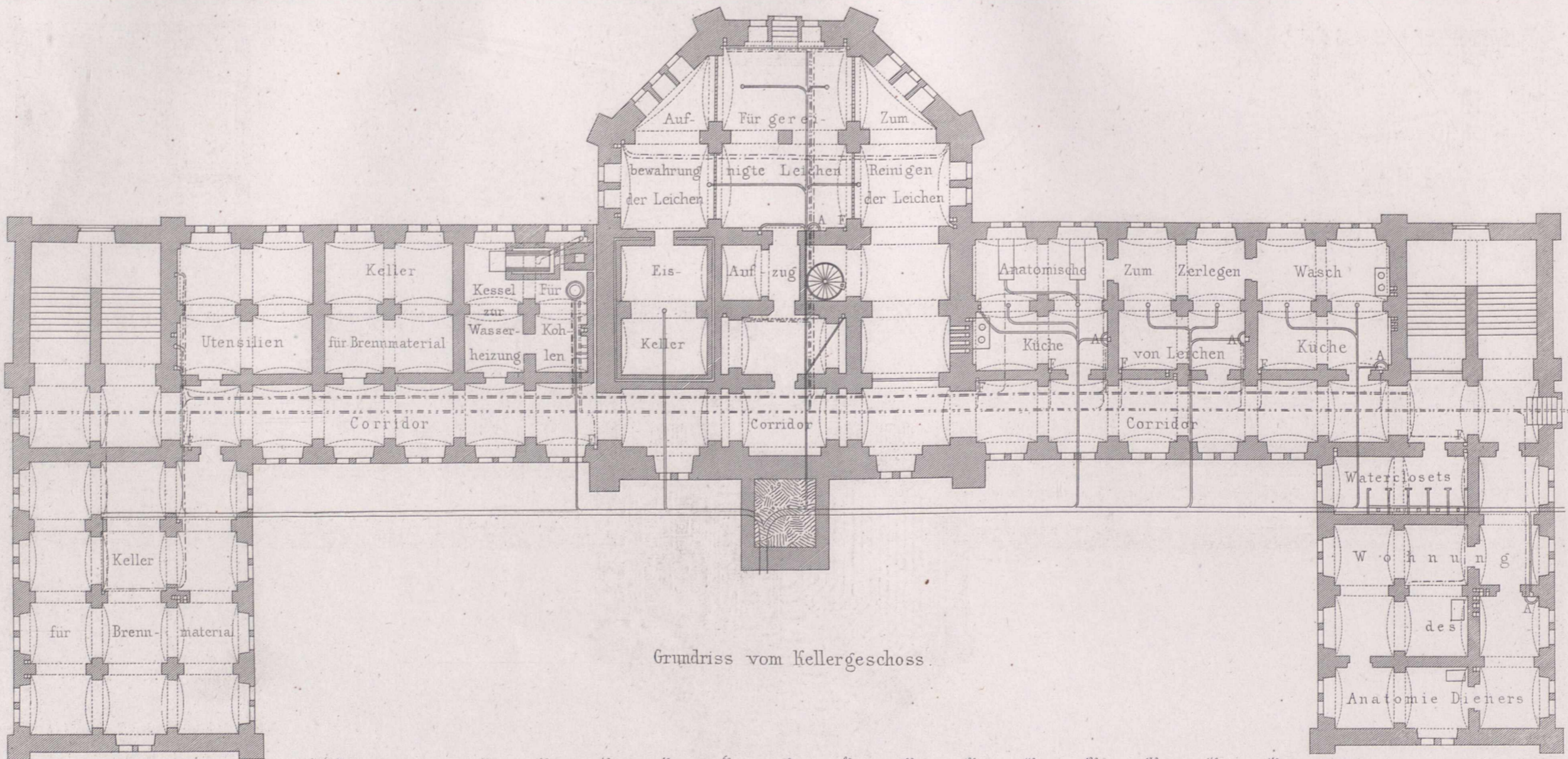

Grundriss vom Kellergeschoss

- - - - - Warmwasserzuleitungen.  
 - - - - - Kaltwasserzuleitungen.  
 ———— Wasser-Abflussröhren.

0 10 20 30 40 50 60 70 80 90 100 110 120 130 140 150 Fuss rhl.

T = Toiletten  
 A = Ausguss  
 F = Feuerhähne



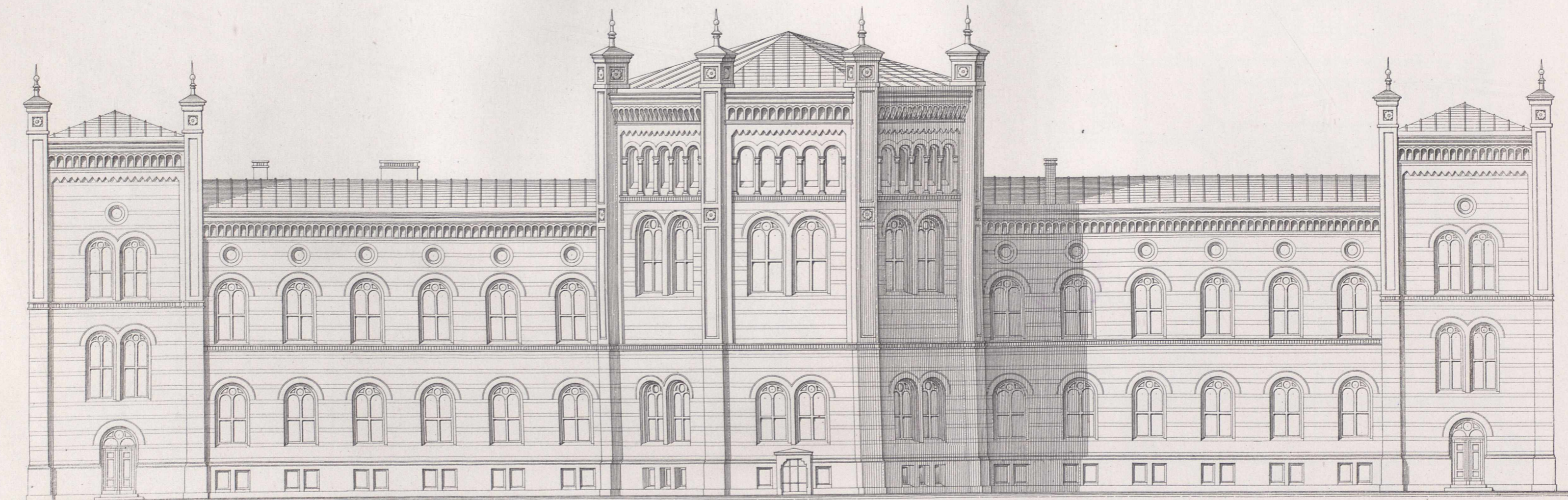

Hintere Ansicht.

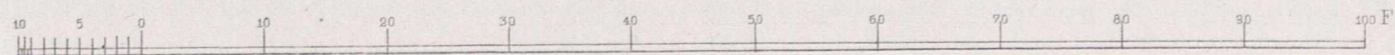

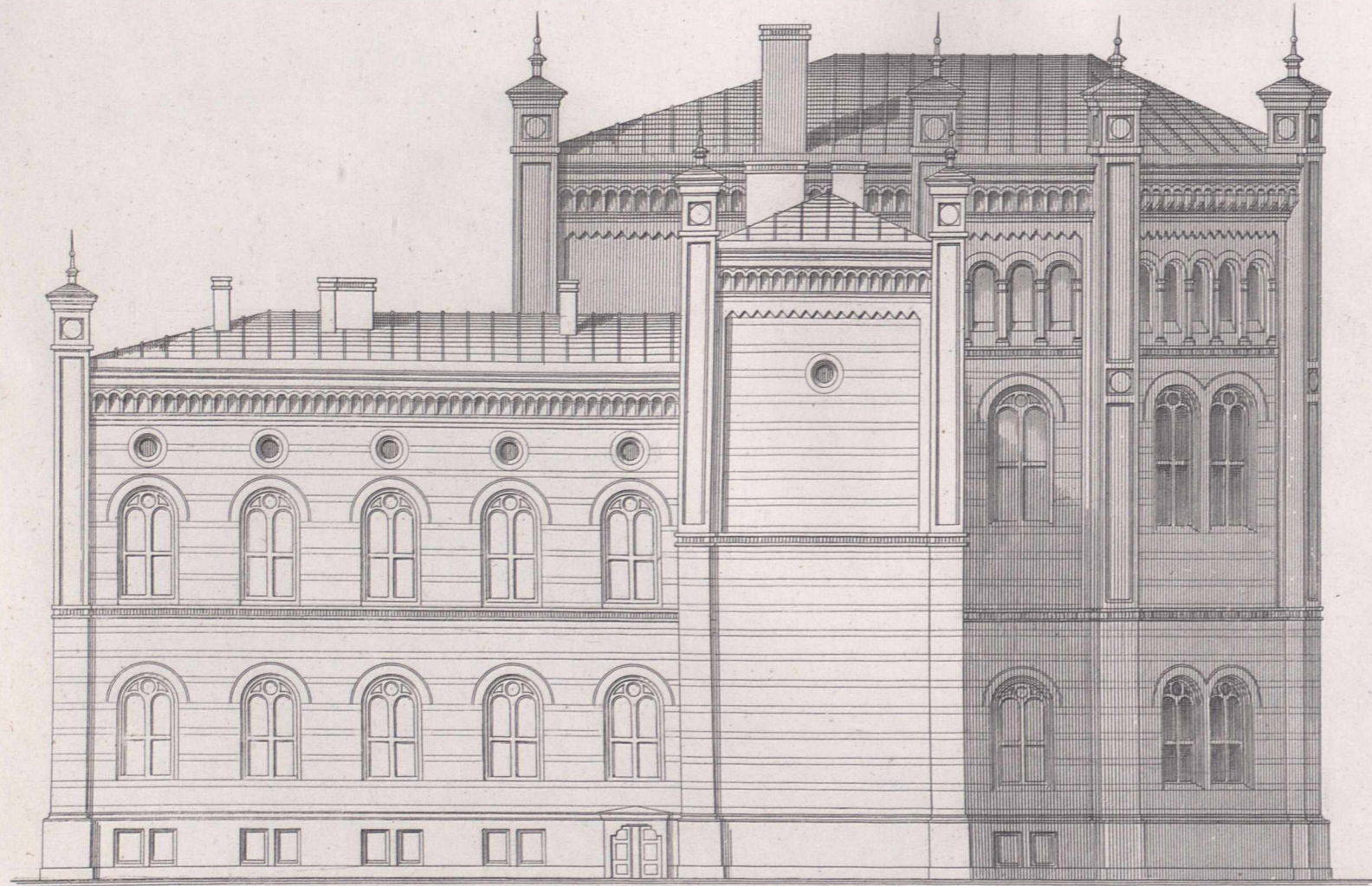

Seitenansicht.

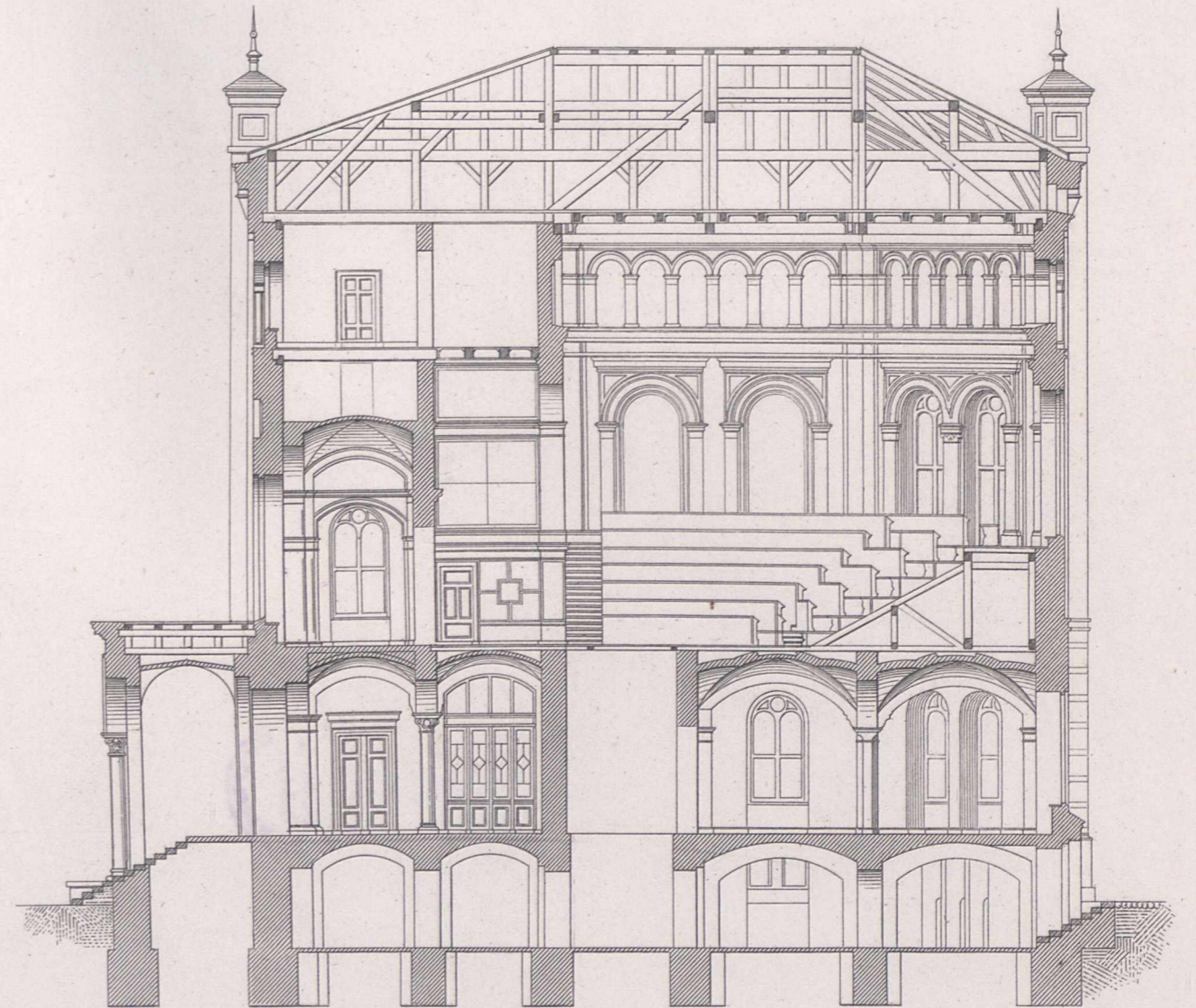

Durchschnitt durch den Mittelbau.

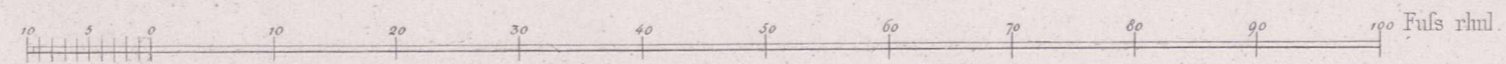

Anatomie - Gebäude zu Berlin.

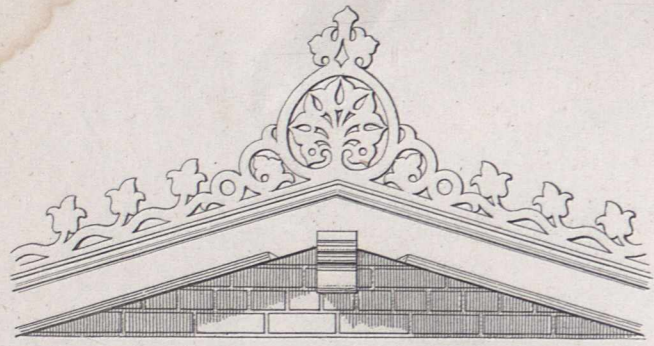

Giebelbekrönung

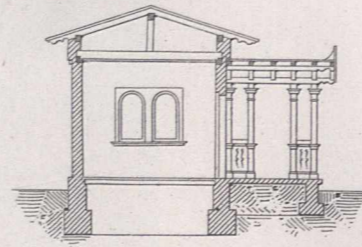
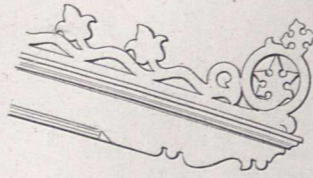

Figur 7.

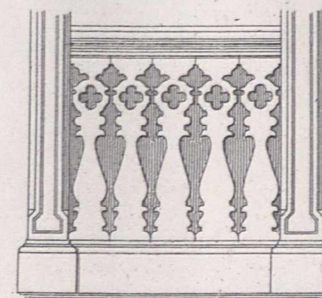

Brüstung d. Halle.

Figur 5.

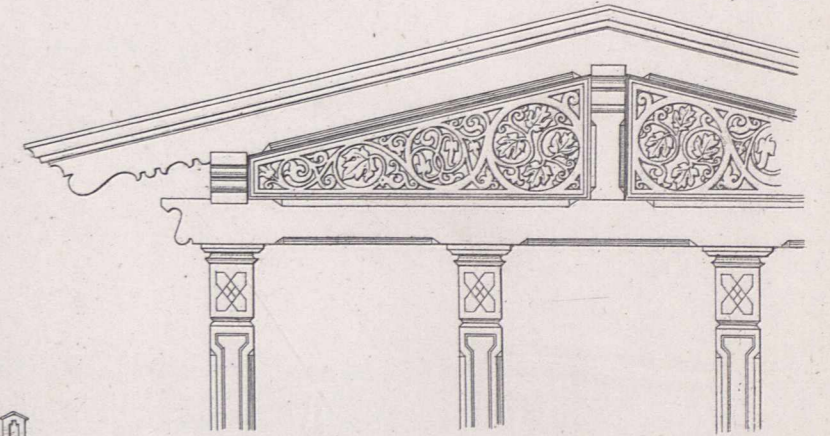

Giebel der Halle.

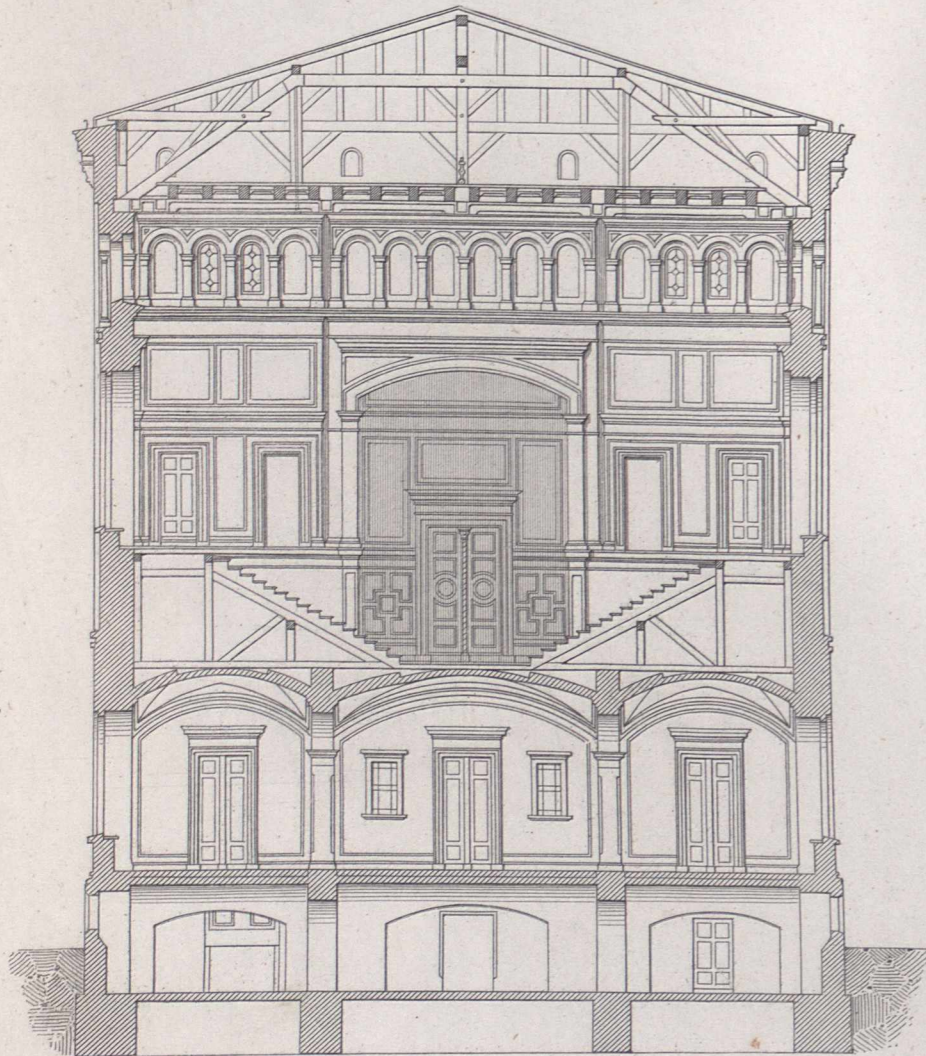

Durchschnitt durch den Mittelbau.

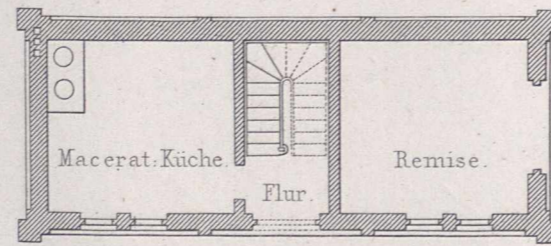

Figur 1.

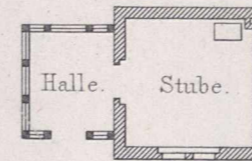

Figur 6.

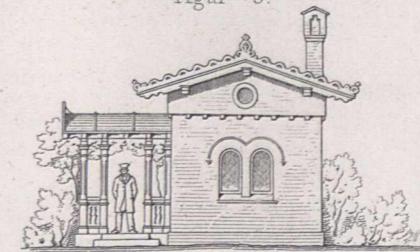

Figur 5-7. Portierhaus.

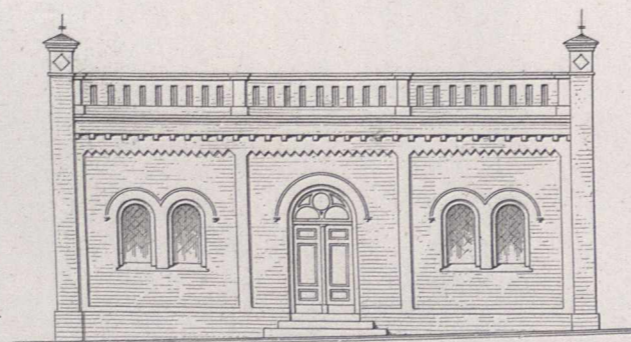

Figur 2.

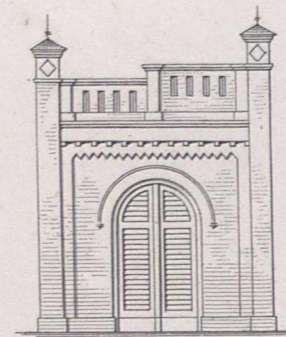

Figur 3.

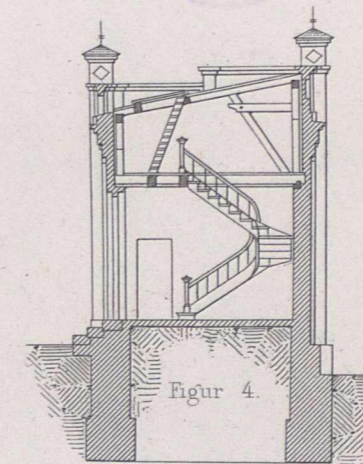

Figur 4.

Figur 1-4 Macerationsgebäude.

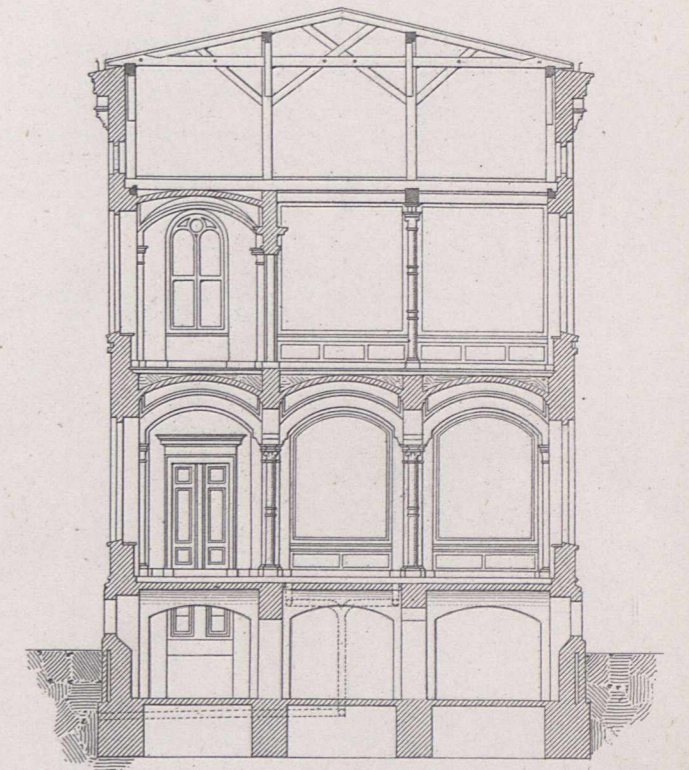

Durchschnitt des Hauptgebäudes.

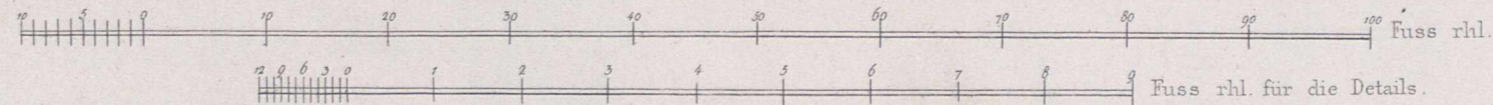



Detail des Portals.

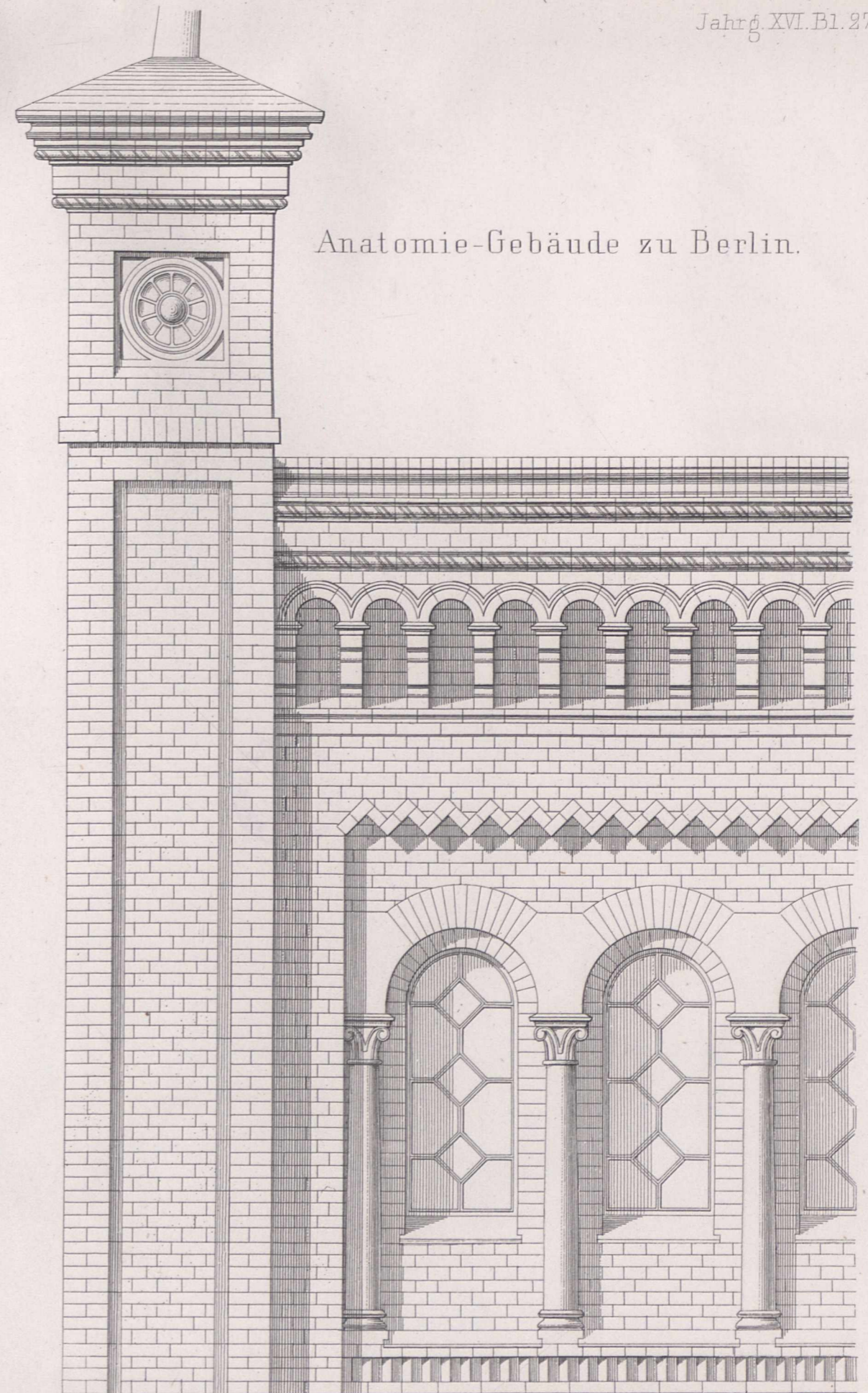
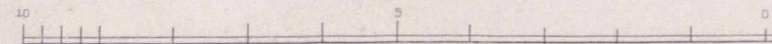

Anatomie-Gebäude zu Berlin.

Detail des Hauptgesimses.

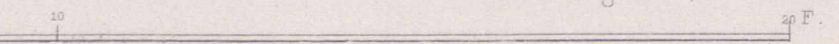

Fig. 1. Detail der gusseisernen Säulen in den Flügeln.

Anatomie-Gebäude zu Berlin.

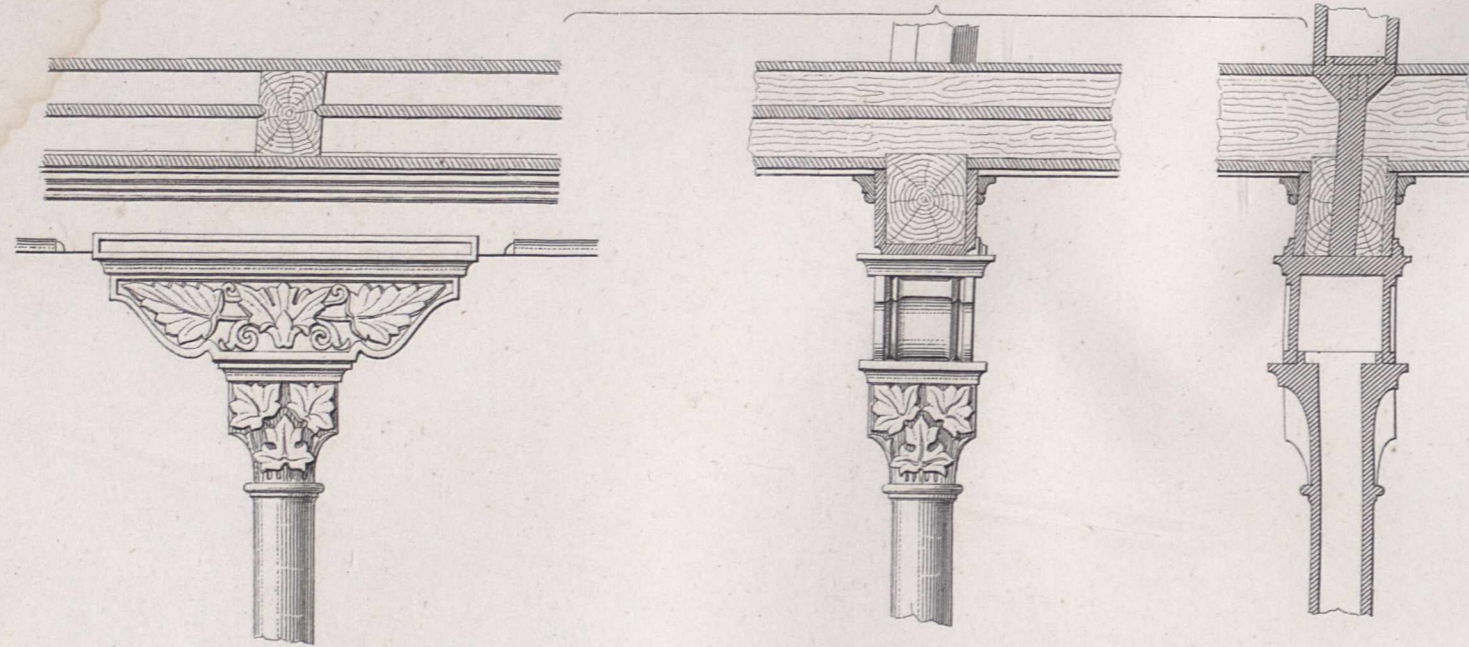

Fig. 5. Scudelle des Mittelbaues.

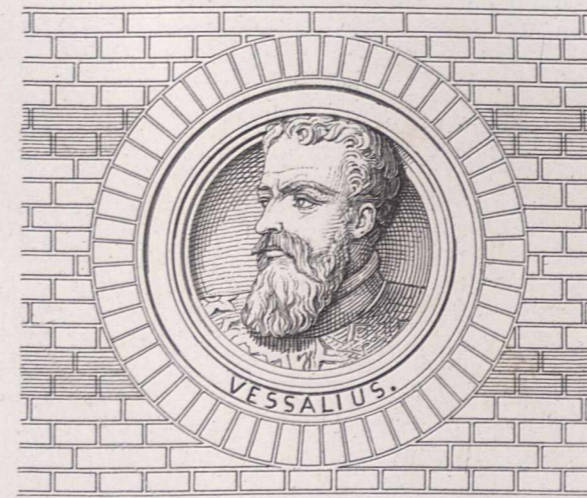

Fig. 7. Console im Auditorium.

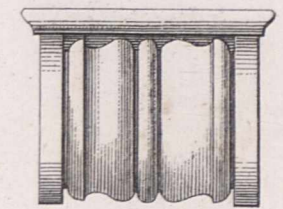

Fig. 2. Pfeiler-Capitell.

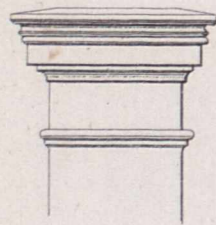

Fig. 3. Thürverdachung.

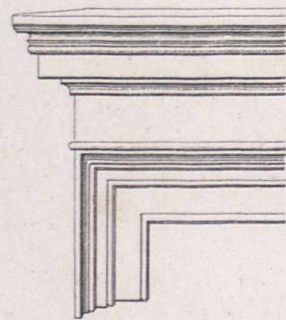

Fig. 4. Schmiedeeisernes Gitter zwischen den Flügeln.

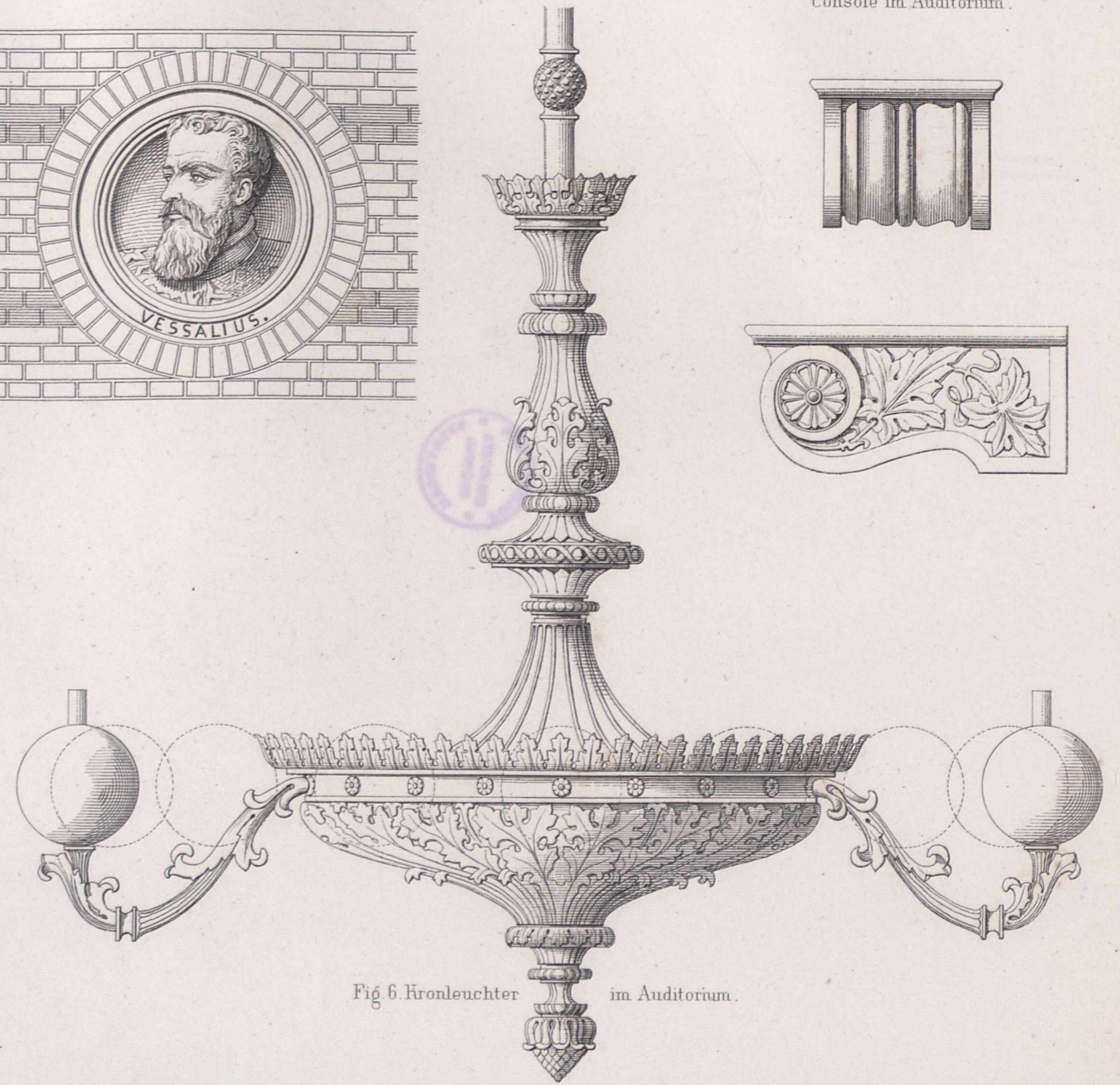
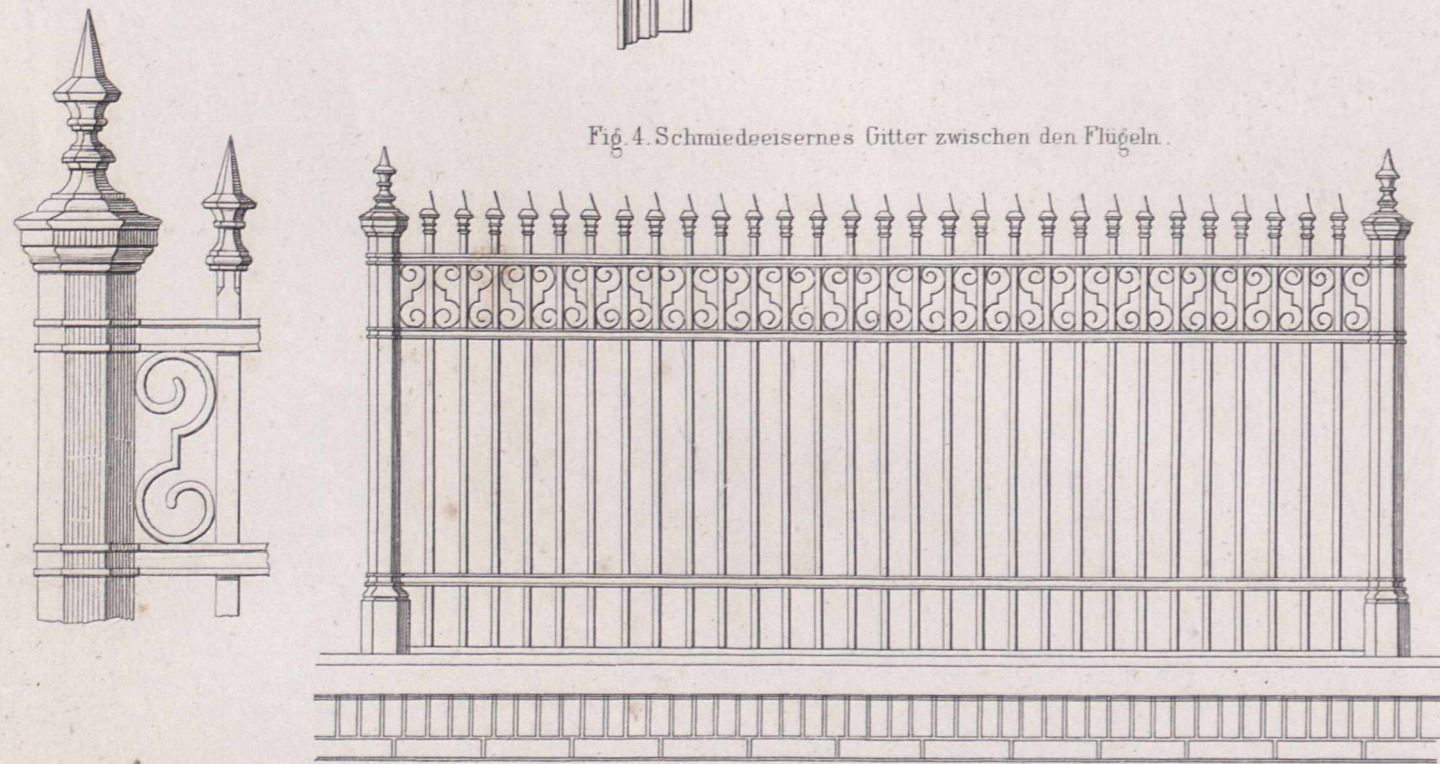
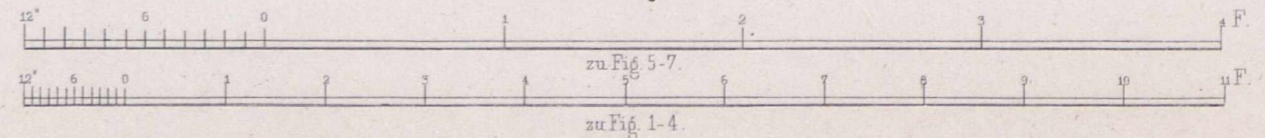

Fig. 6. Kronleuchter im Auditorium.



Kessel zur Wasserheizung.

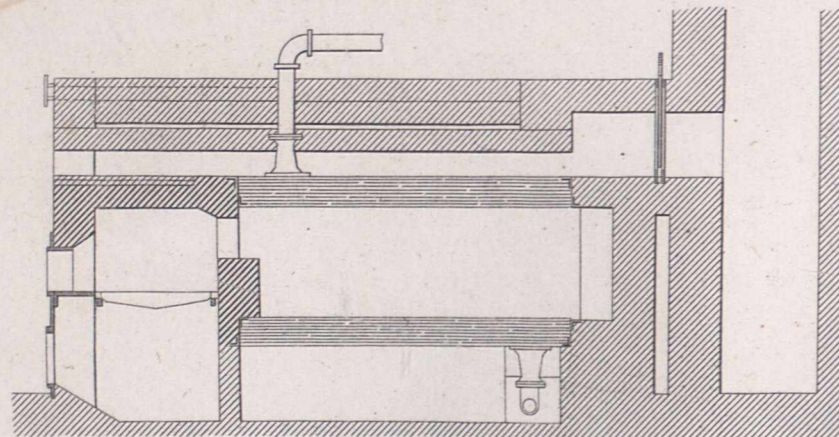

Fig. 2. Längenschnitt.

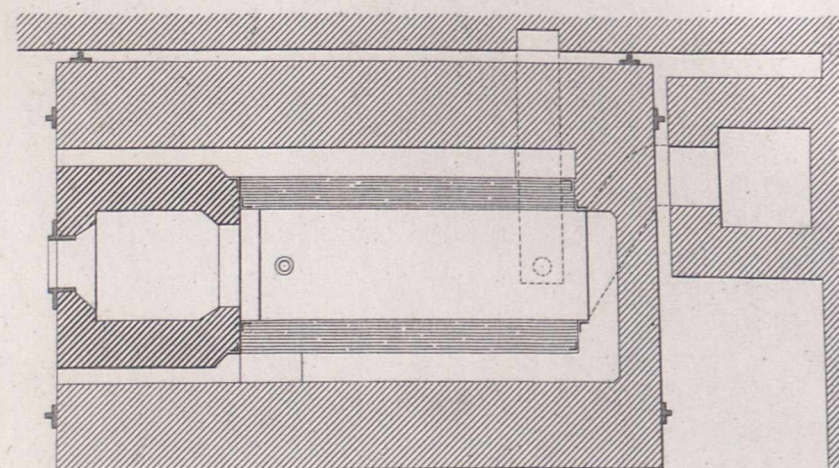

Fig. 3. Grundriss.

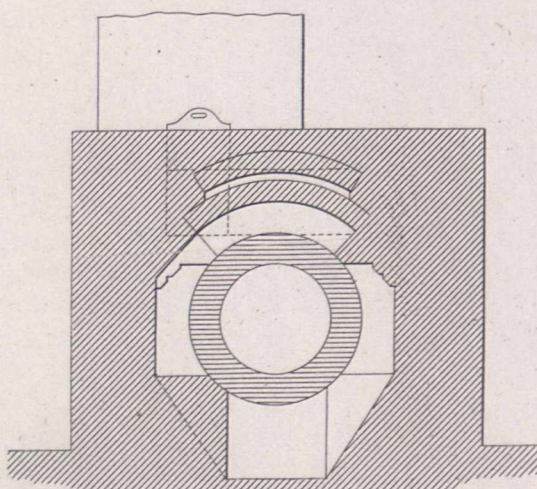
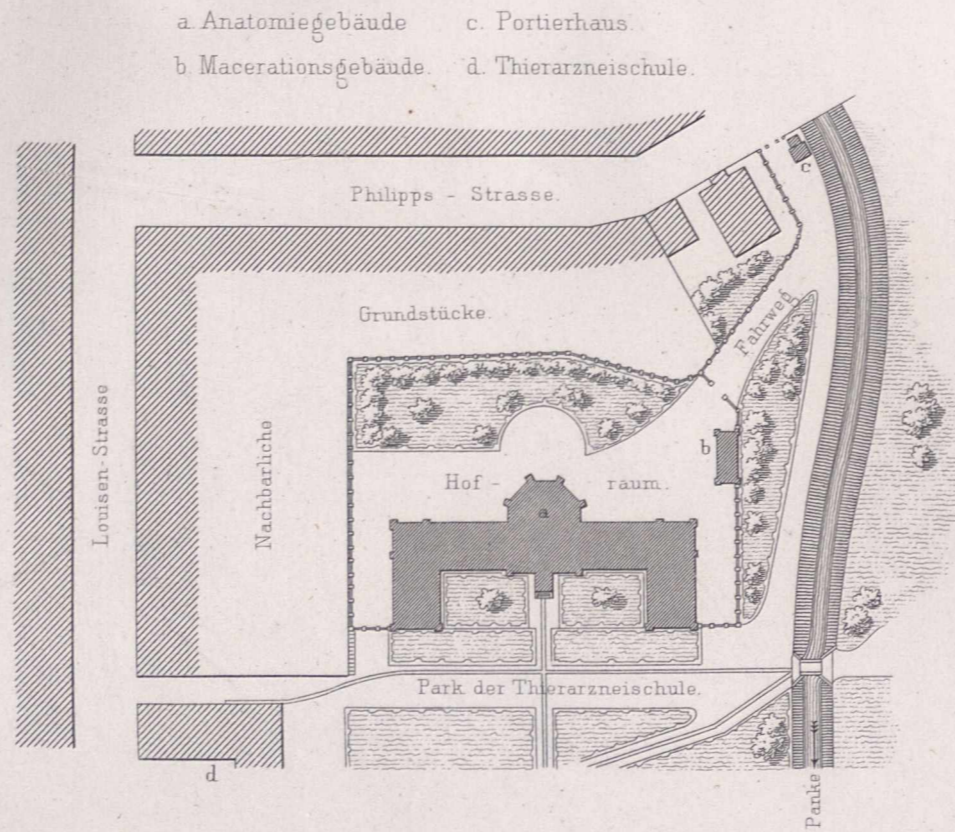

Fig. 4. Querschnitt.

A. Cremer erf.

Fig. 1. Situationsplan.



- a. Anatomiegebäude
- b. Macerationsgebäude
- c. Portierhaus
- d. Thierarzneischule.

Warmwasserkessel.

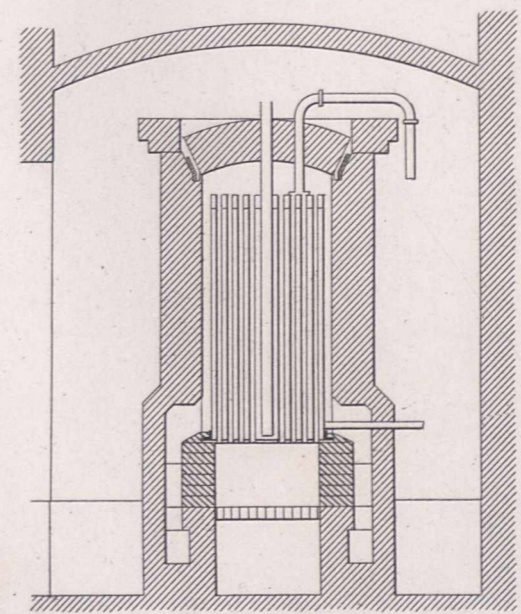

Fig. 5. Durchschnitt.

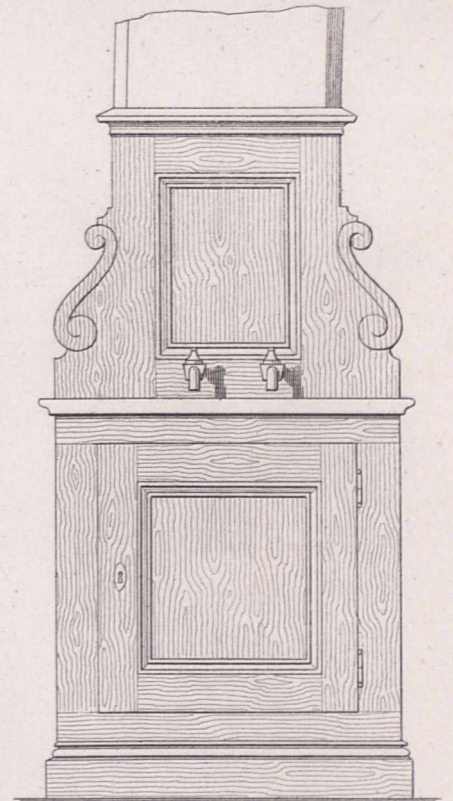
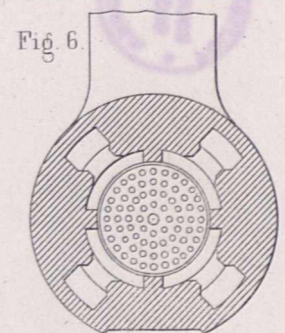

Fig. 8. Toilette.

Fig. 6.



Grundrisse des Warmwasserkessels.

Fig. 7.

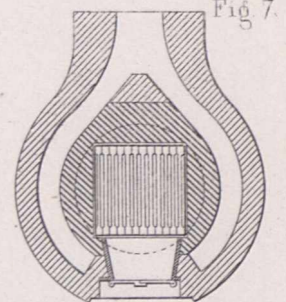
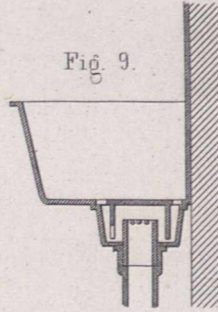

Fig. 9.



Ausguss.

Fig. 10.

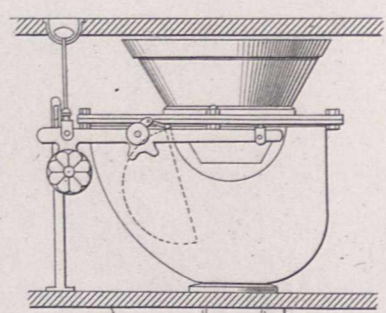
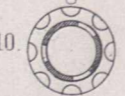

Fig. 11.

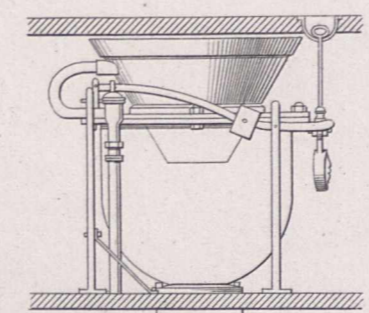
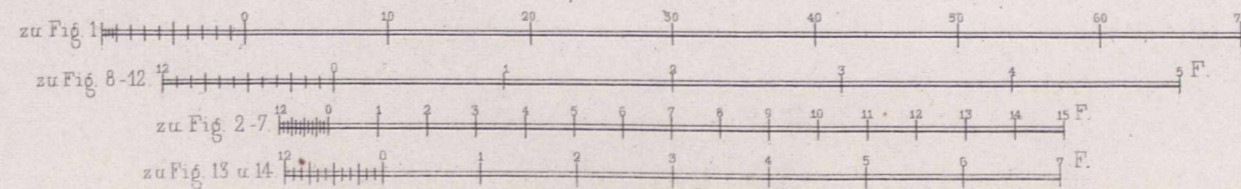

Fig. 12.



Ernst & Korn. Berlin.

Leichen-Fahrtisch.

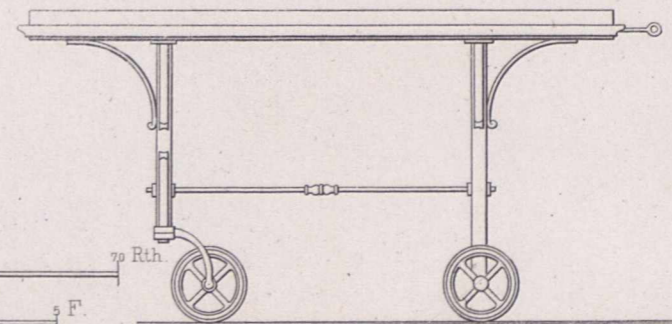

Fig. 13.

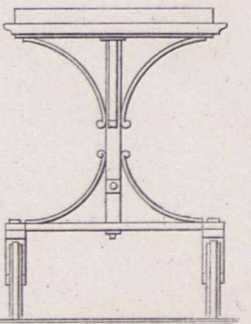
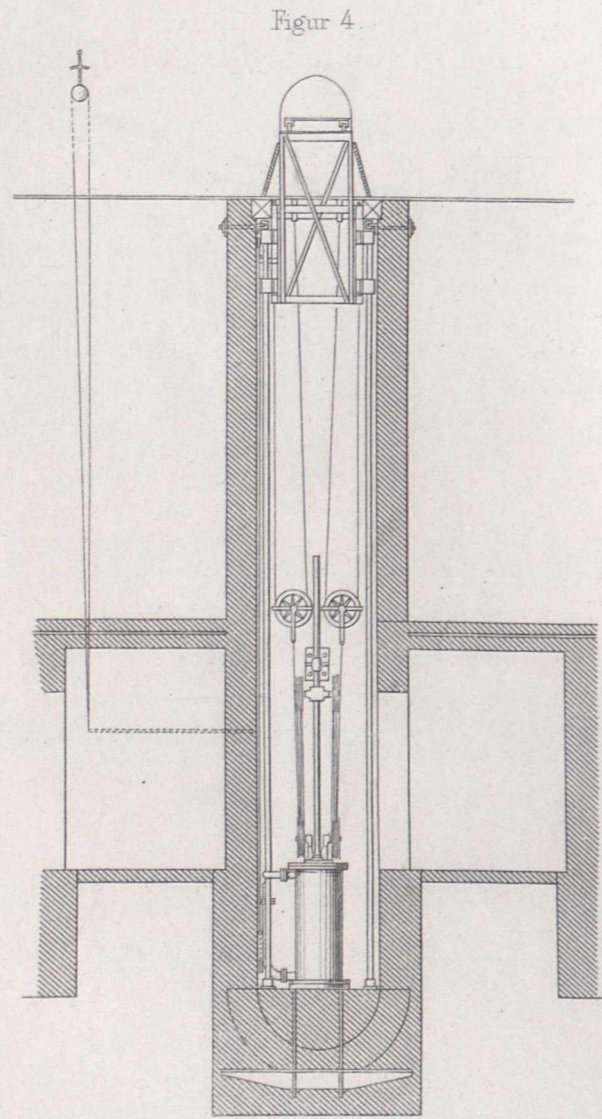

Fig. 14.

Wäther gest.

Hydraulischer Aufzug.



Querschnitt.

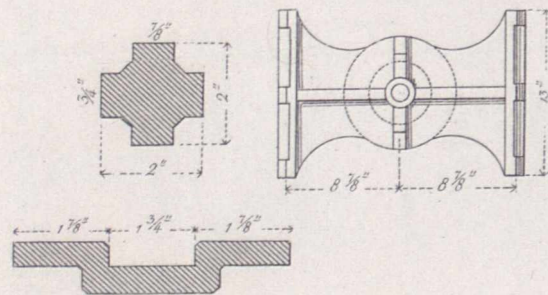

A. Cremer erf.

Anatomie - Gebäude zu Berlin.

Figur 1.

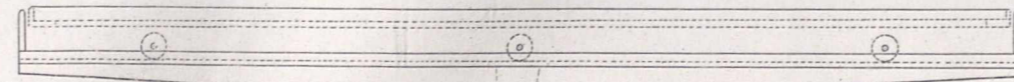

Ansicht des

Demonstrationstisches.

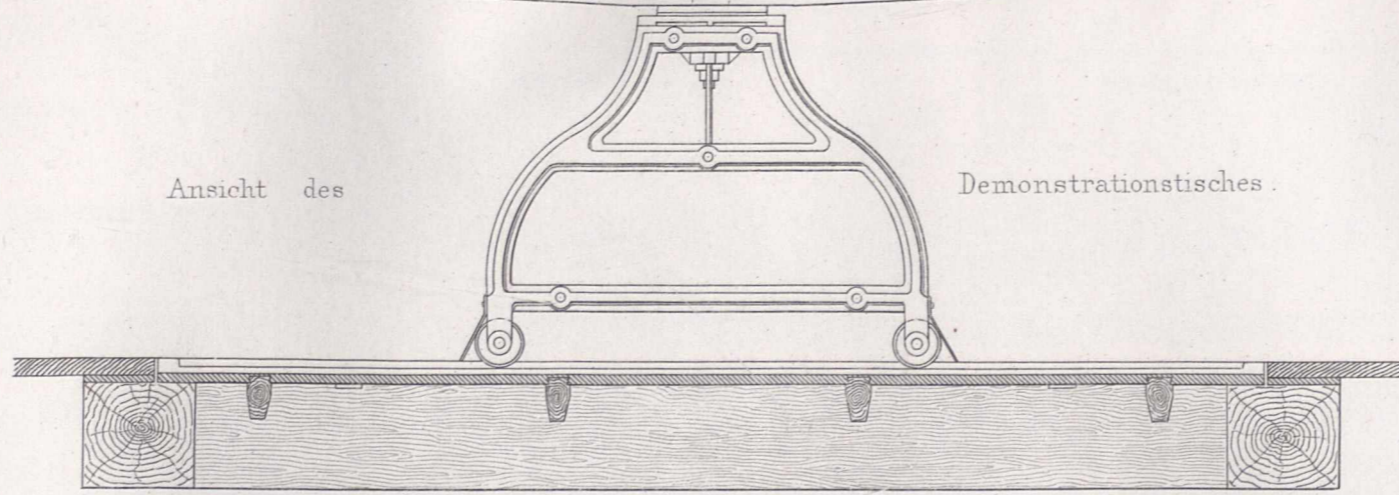

Figur 2.

Grundriss des

Tischrahmens.

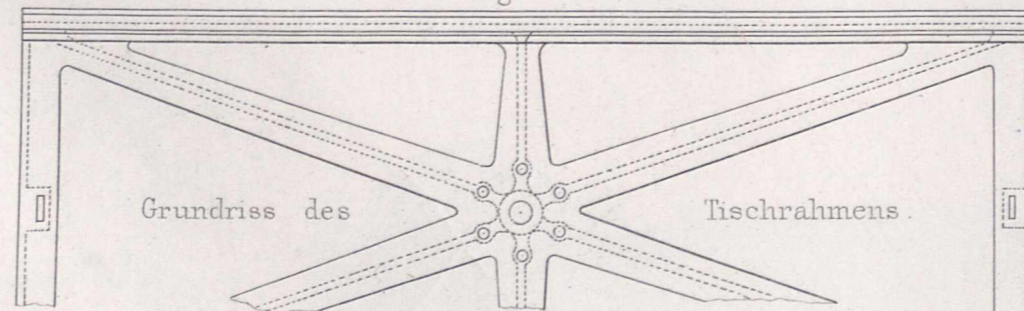

Figur 6.

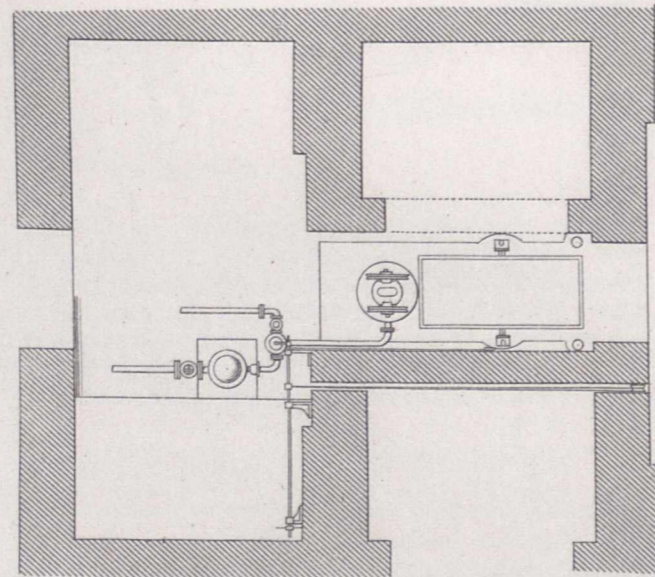

Grundriss.

Figur 3.

Querdurchschnitt des

Demonstrationstisches

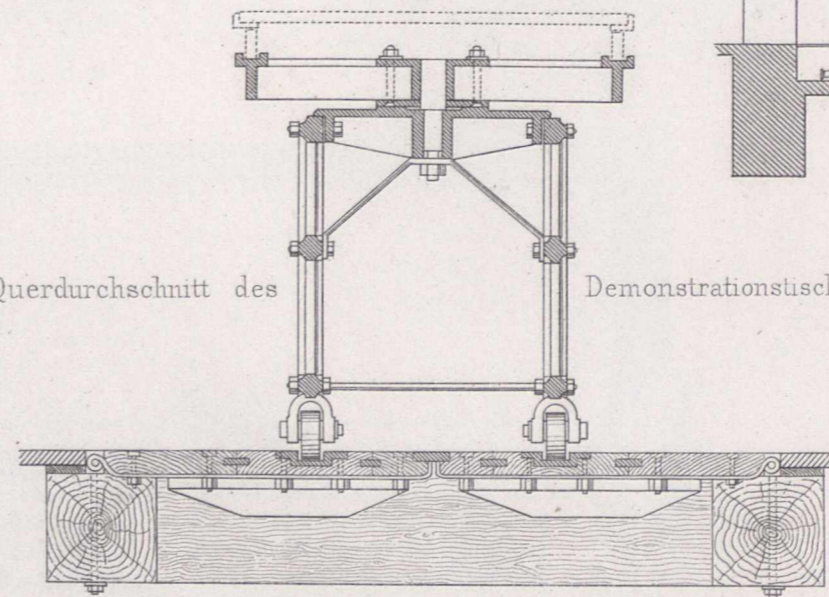

Hydraulischer Aufzug.

Figur 5.

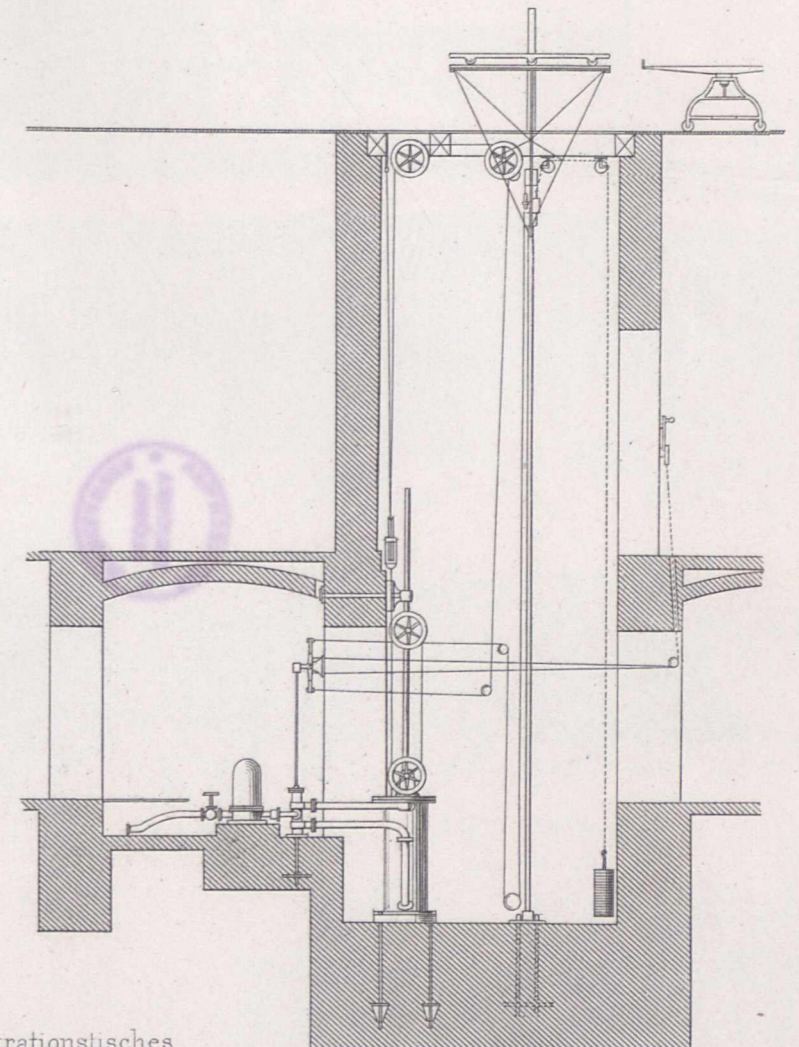

Laengenschnitt.

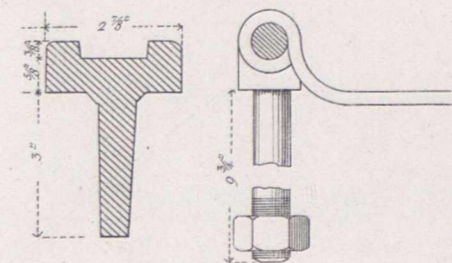

Ritter gest.

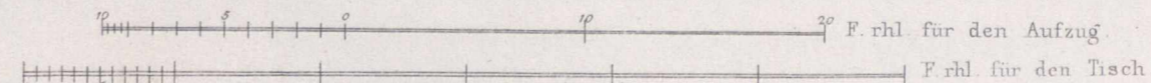

Ernst & Korn. Berlin.

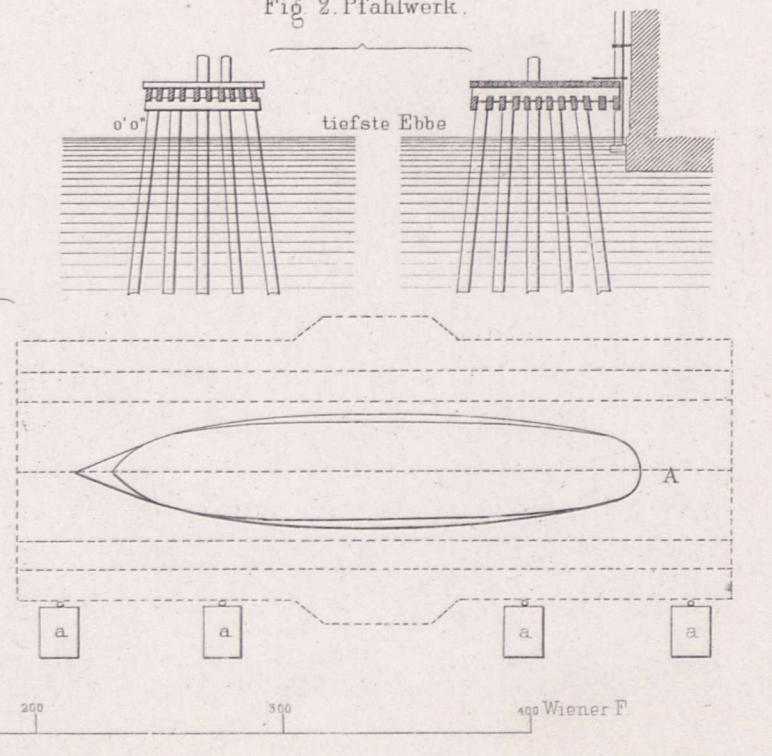
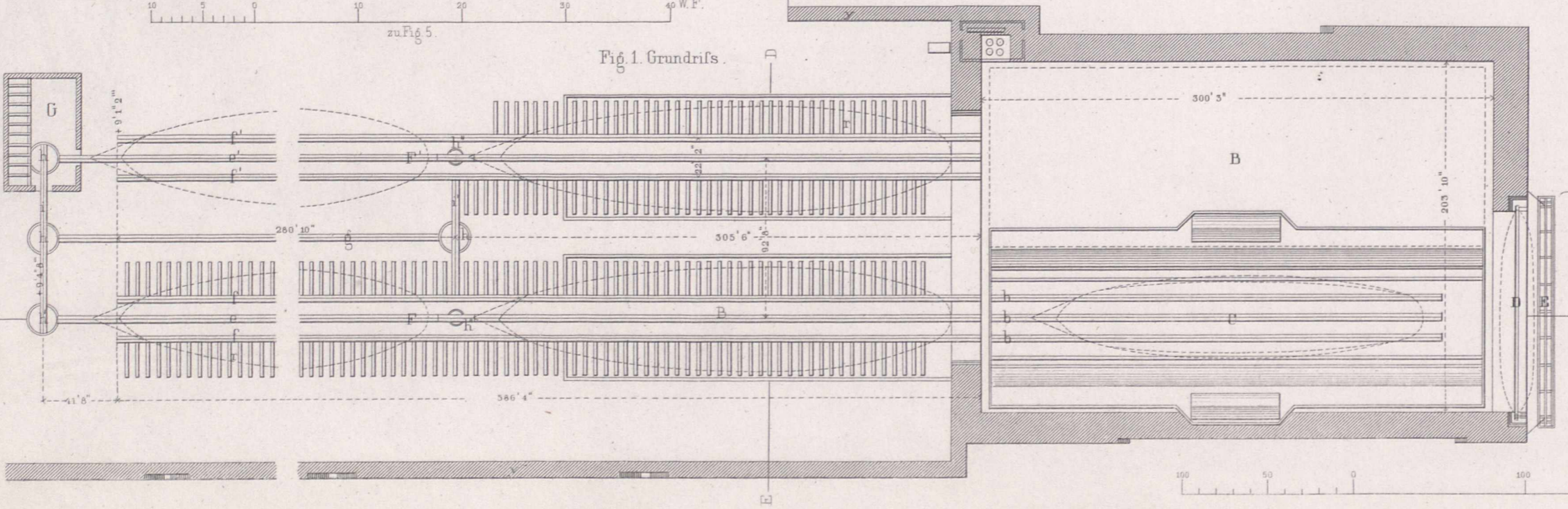
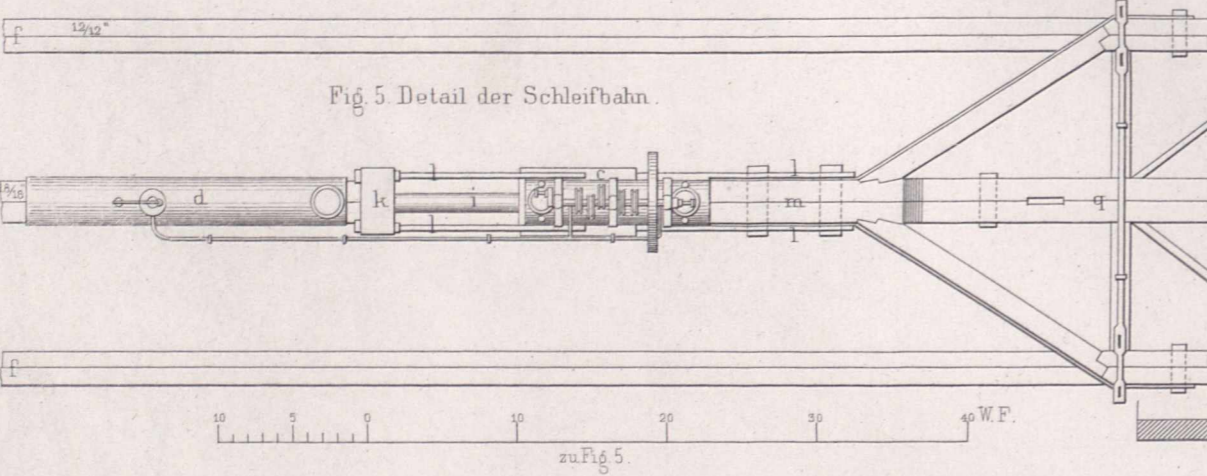
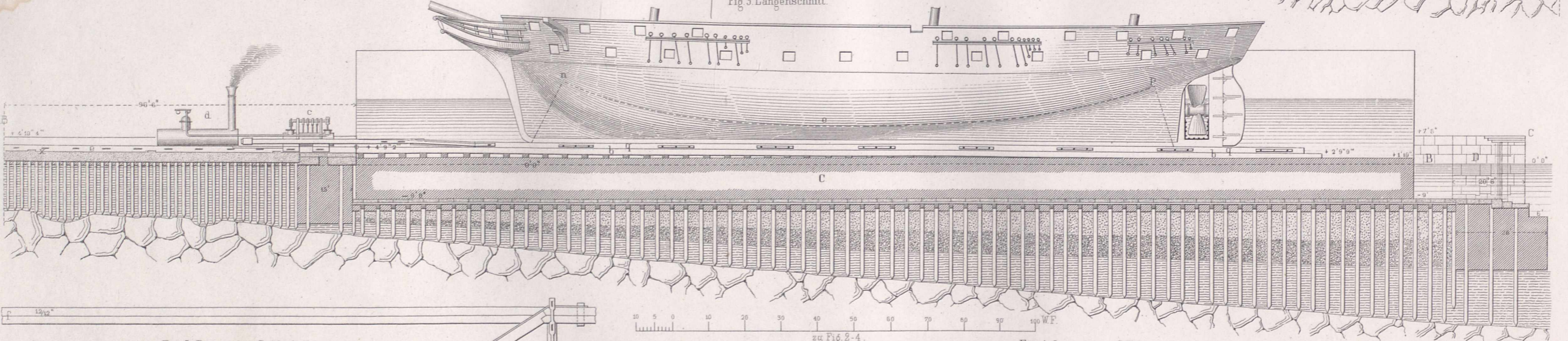
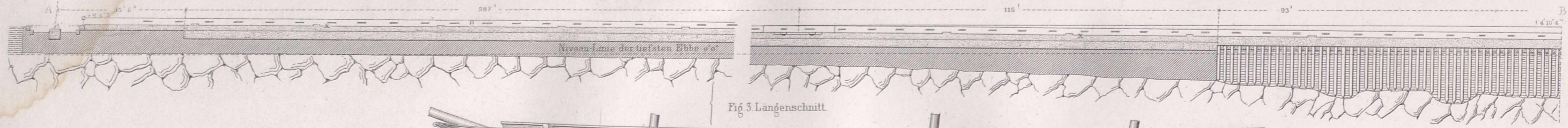



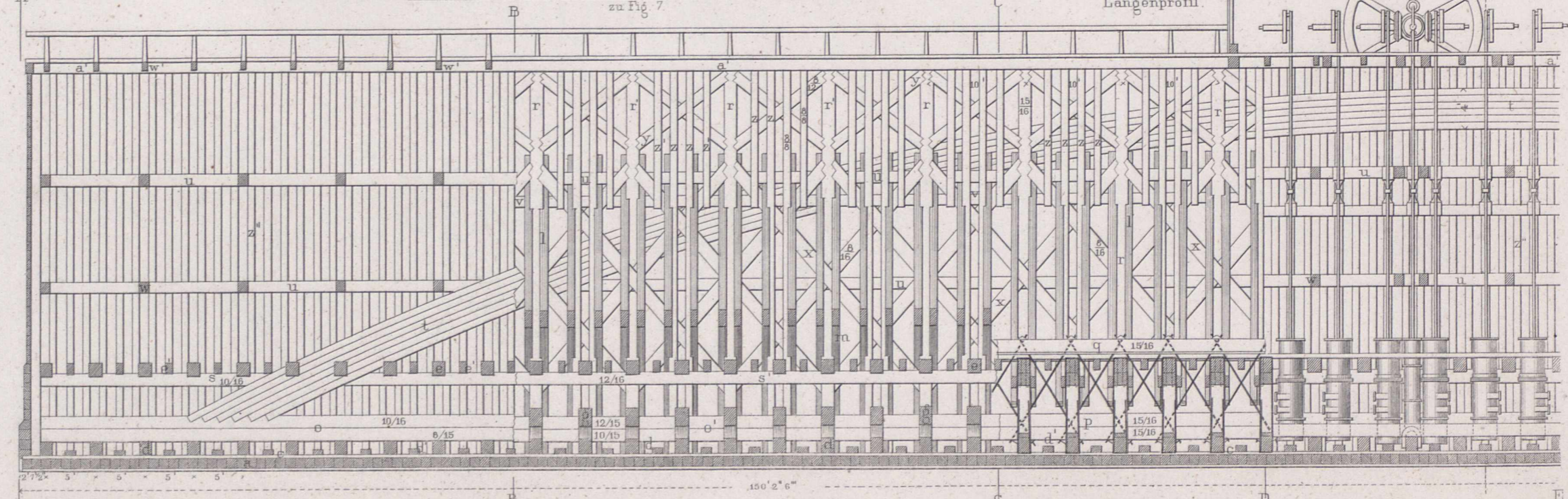
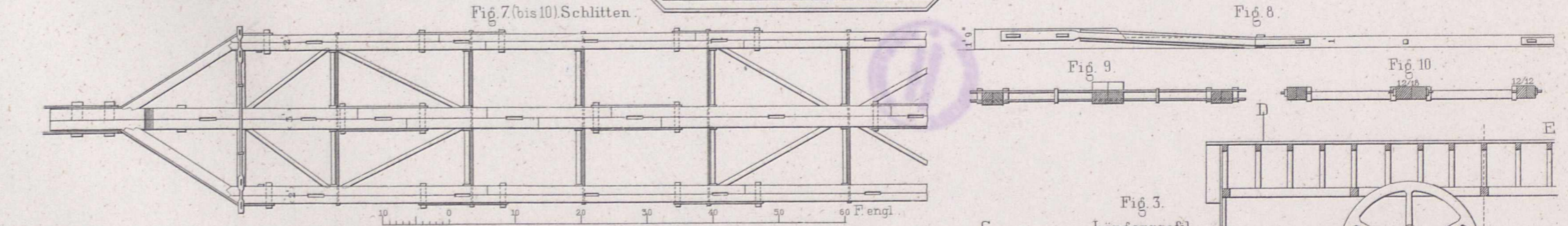
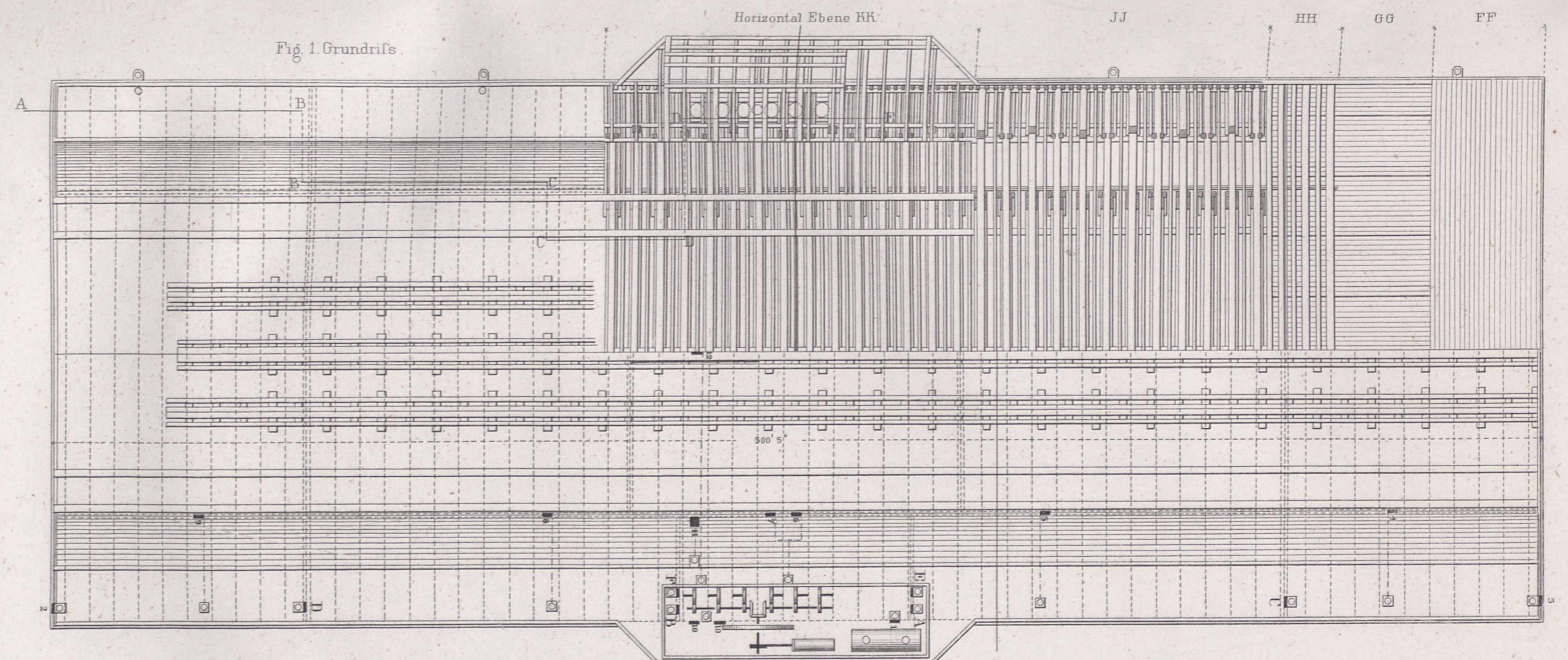
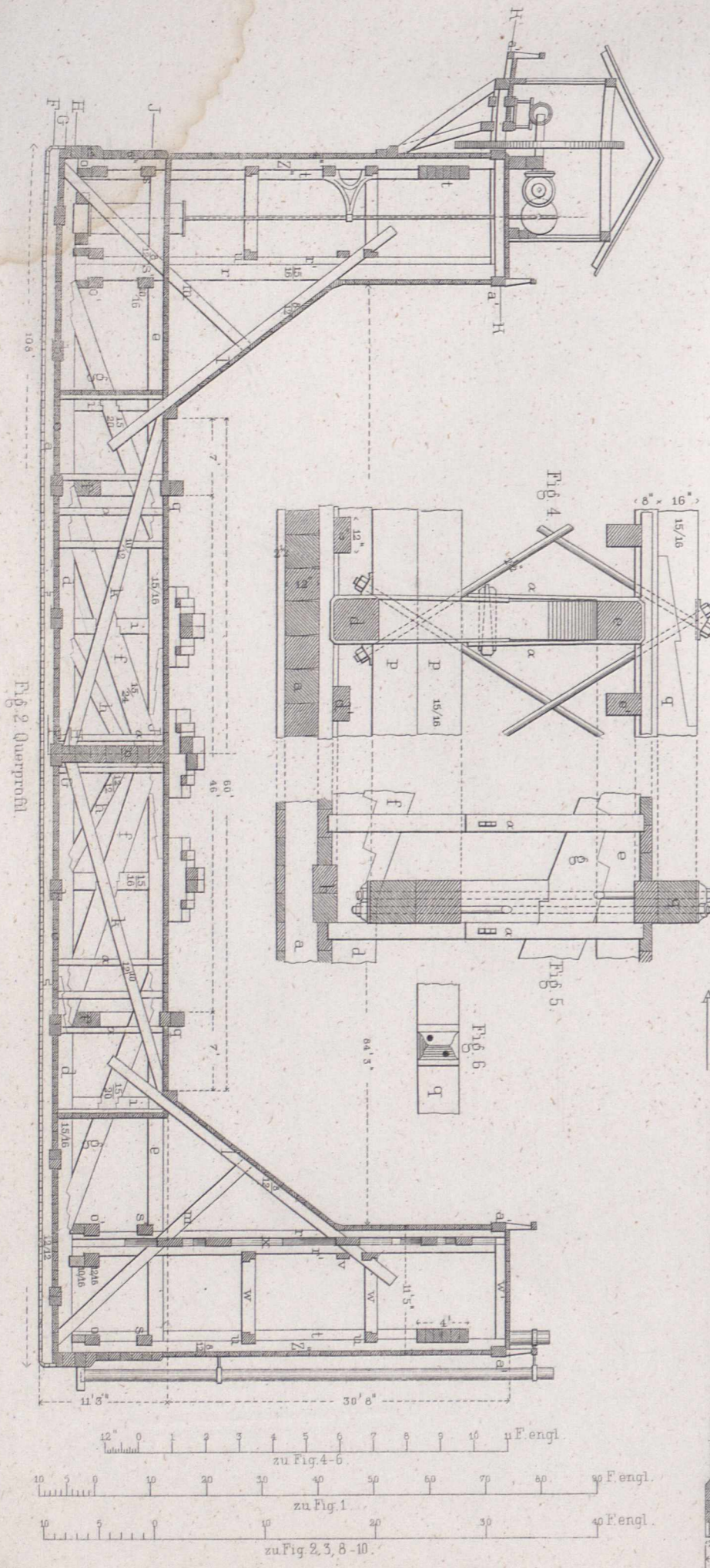

Fig. 1 Grundriss der Pfahlwände.

Das Bassin.

Fig. 7 Grundriss des Bassins.

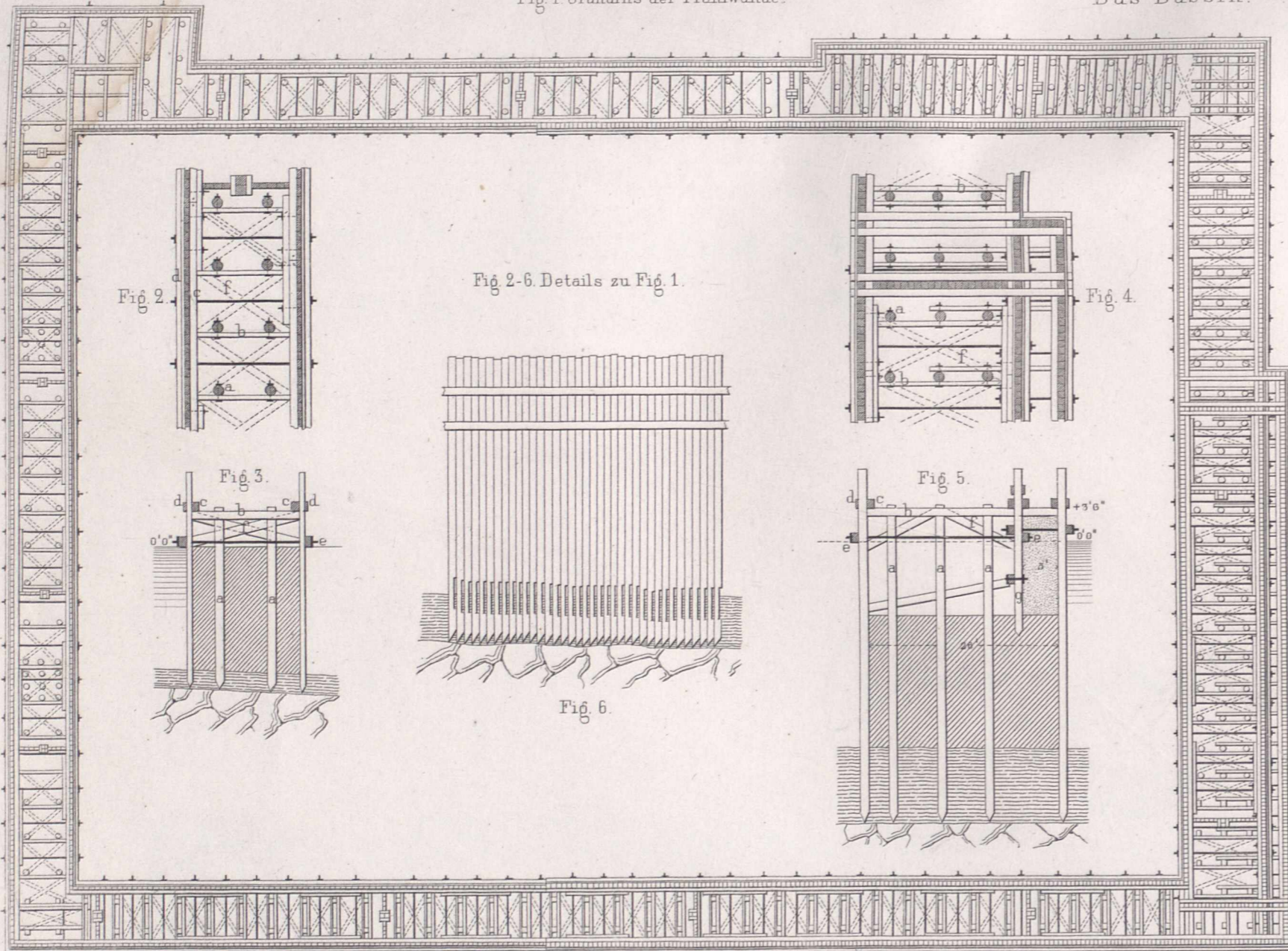

Fig. 2-6. Details zu Fig. 1.

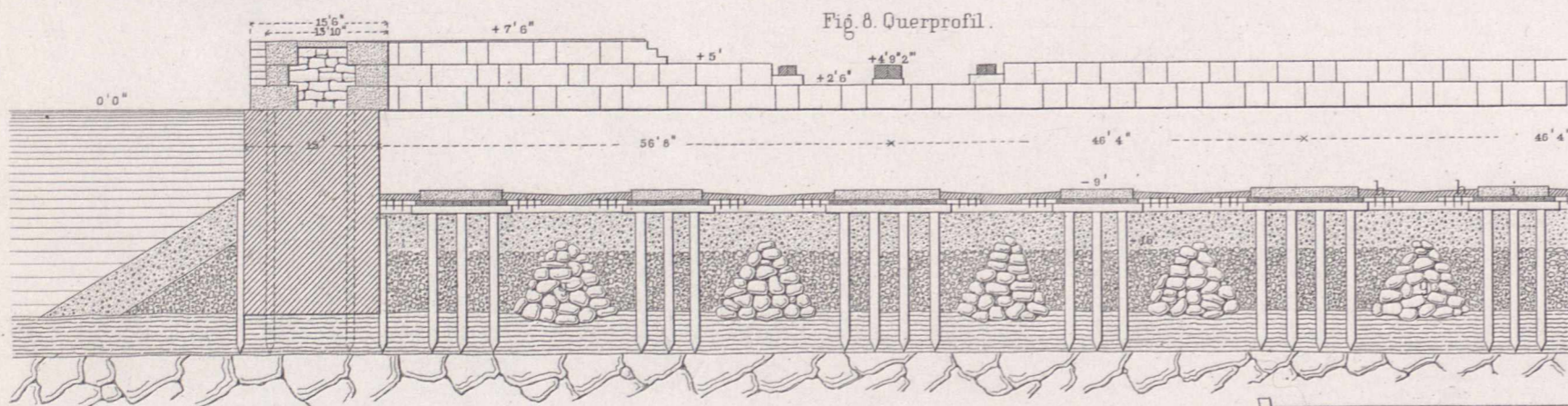
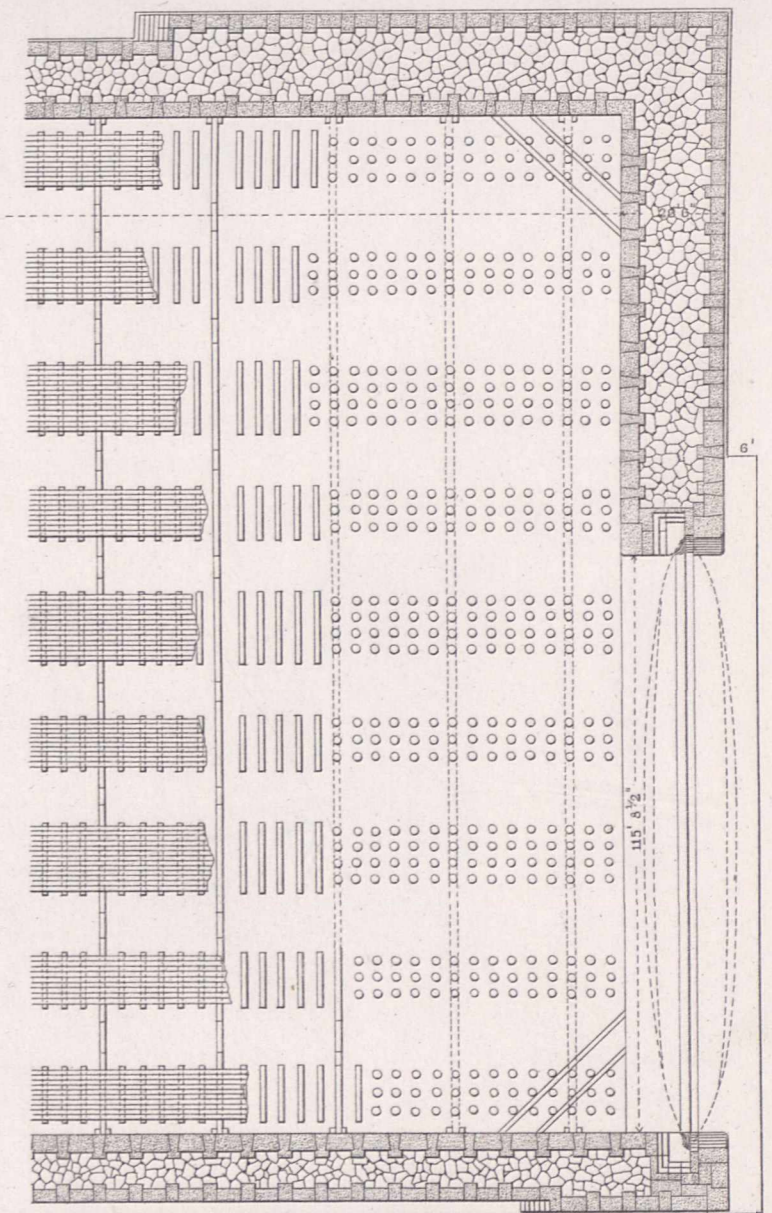
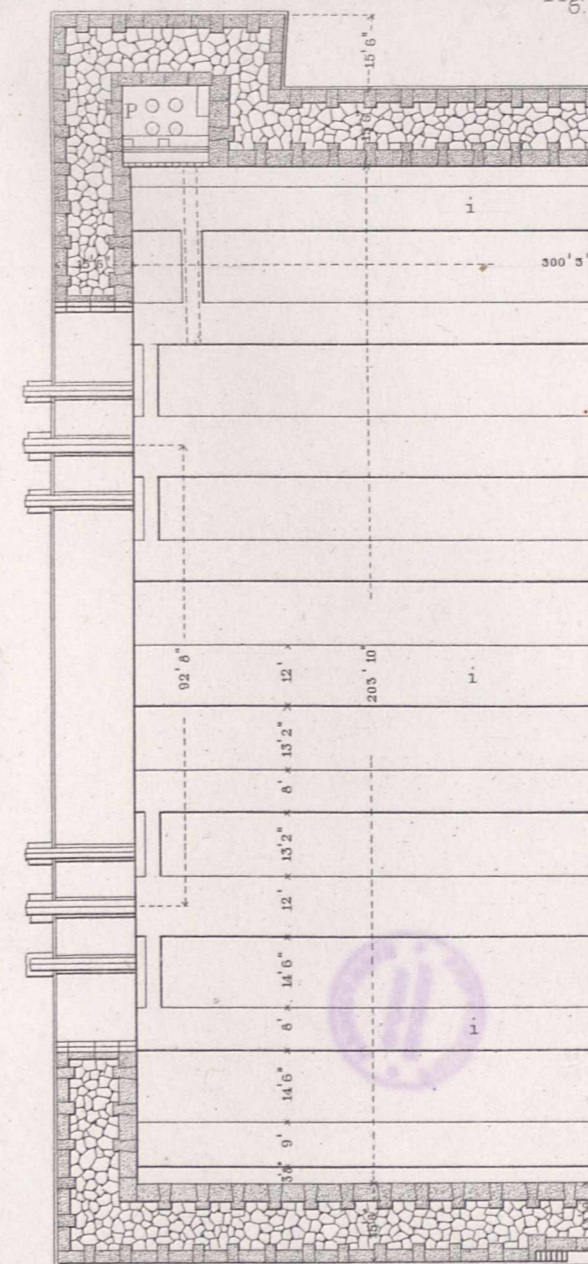

Fig. 8. Querprofil.

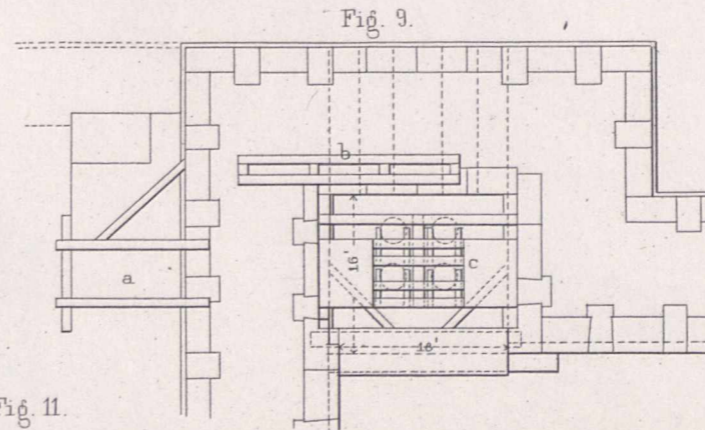

Fig. 9.

Fig. 9 u. 10. Ausmauerung der Pumpenkammer.

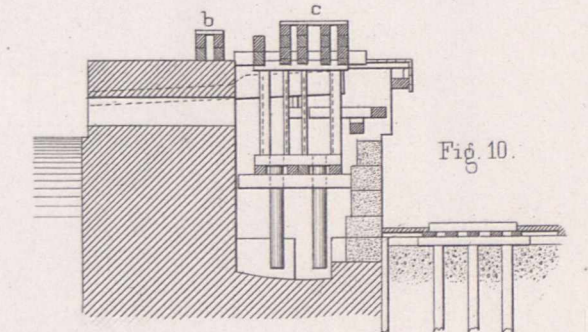
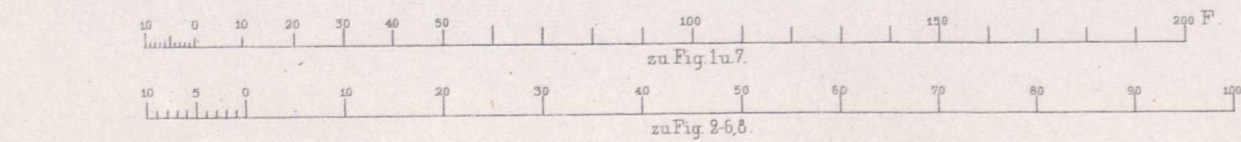

Fig. 10.



zu Fig. 7 u. 9.

zu Fig. 2-6, 8.

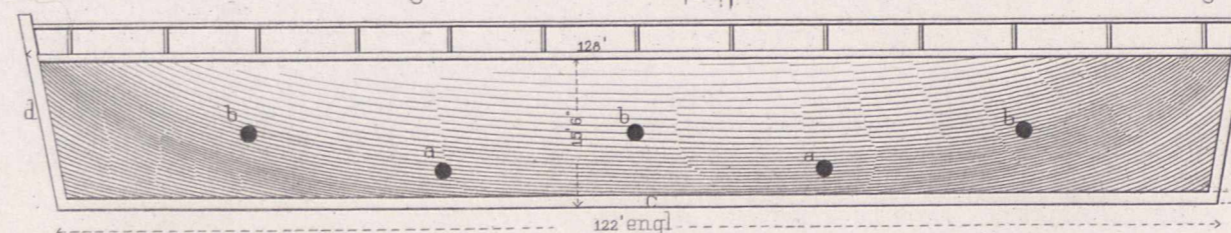

Fig. 11.

Fig. 11 u. 12. Schwimmthor.

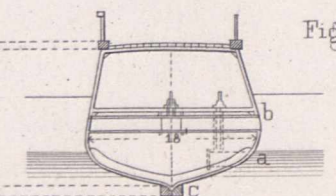
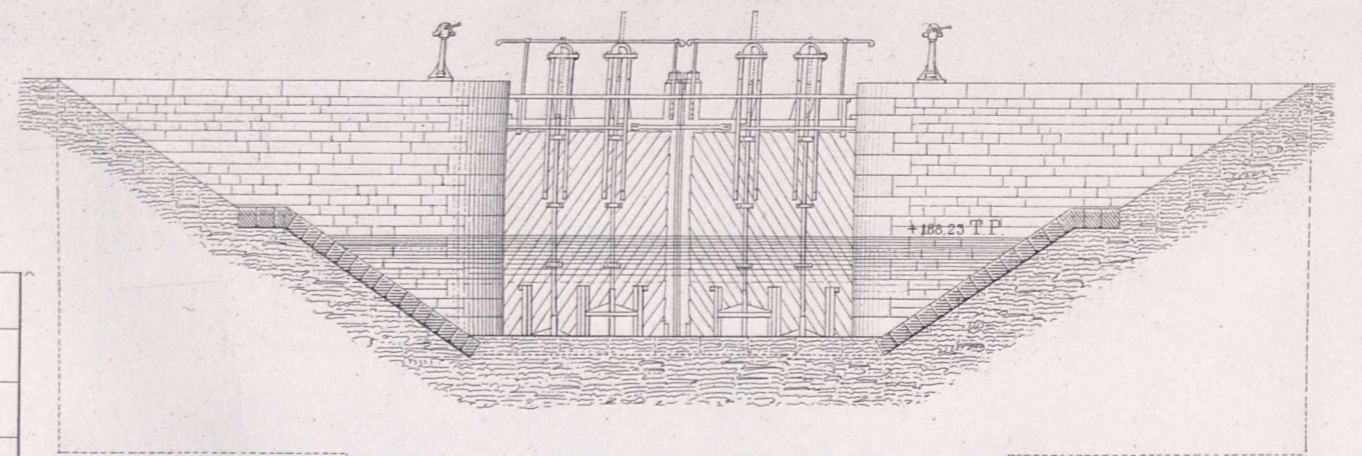
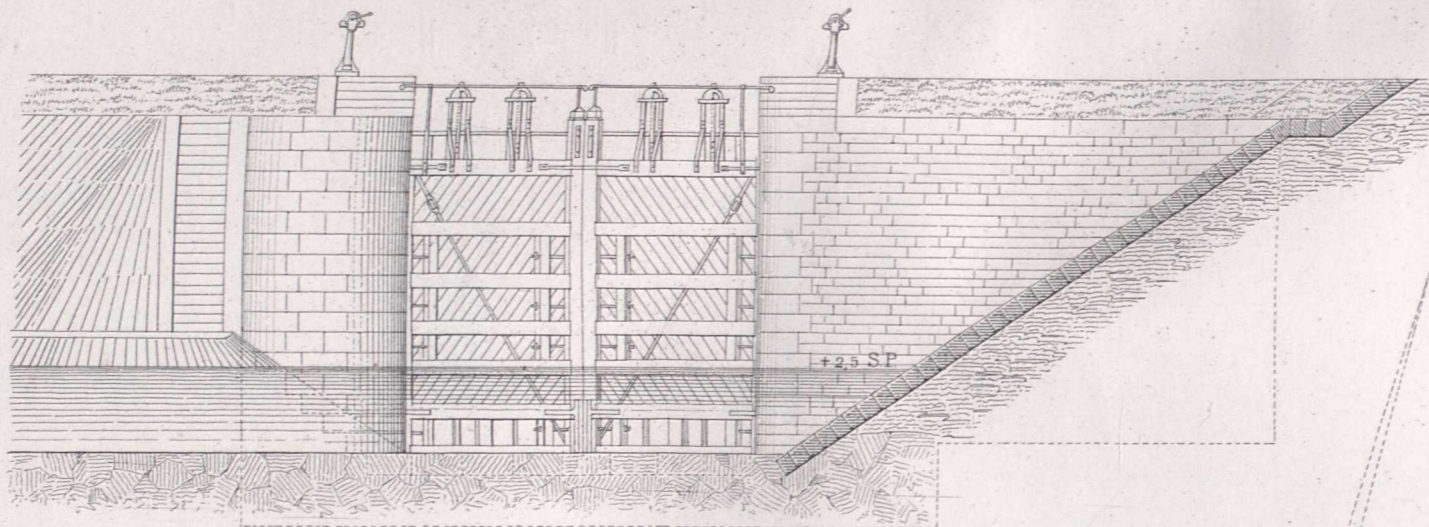

Fig. 12.

Ansicht des Oberhauptes.

Schleuse bei Louisenthal.

Ansicht des Unterhauptes.



Obere Ansicht

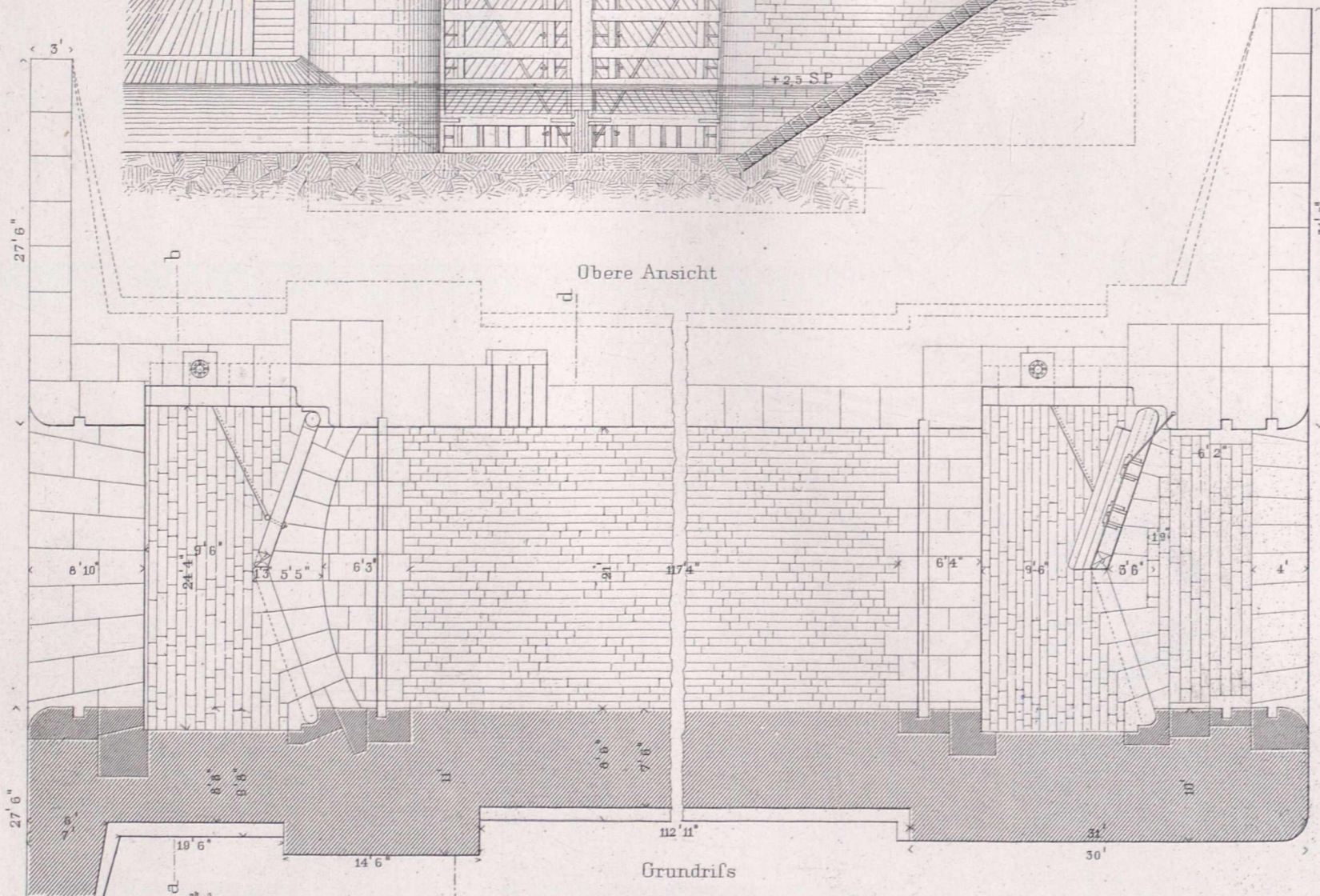

Grundriß

Innere Ansicht.

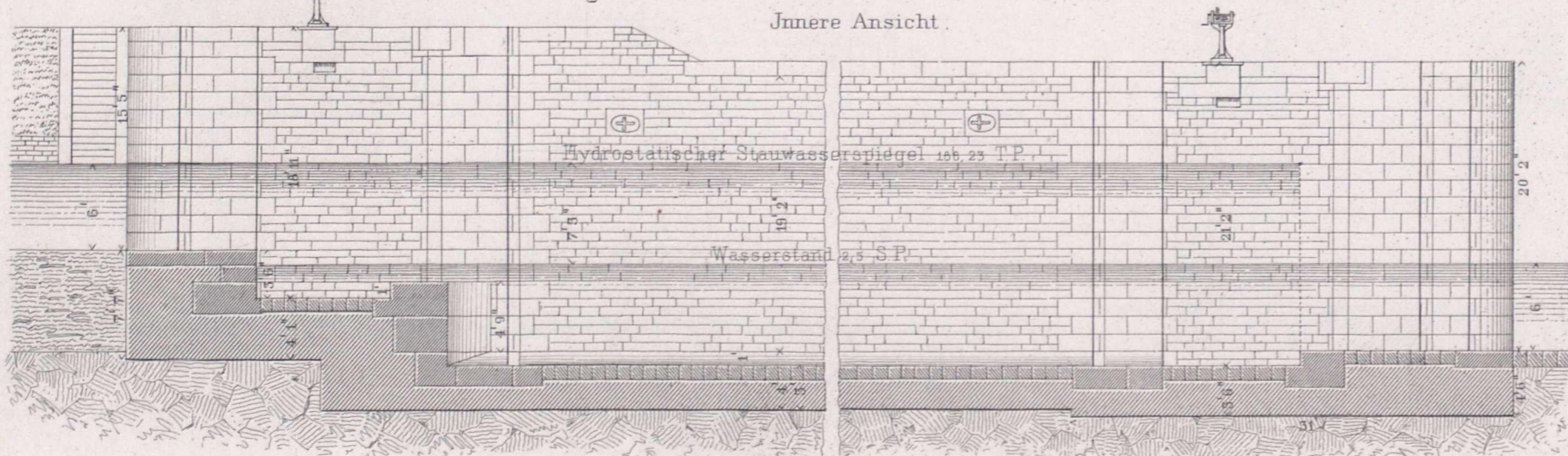

Querschnitt nach ab.

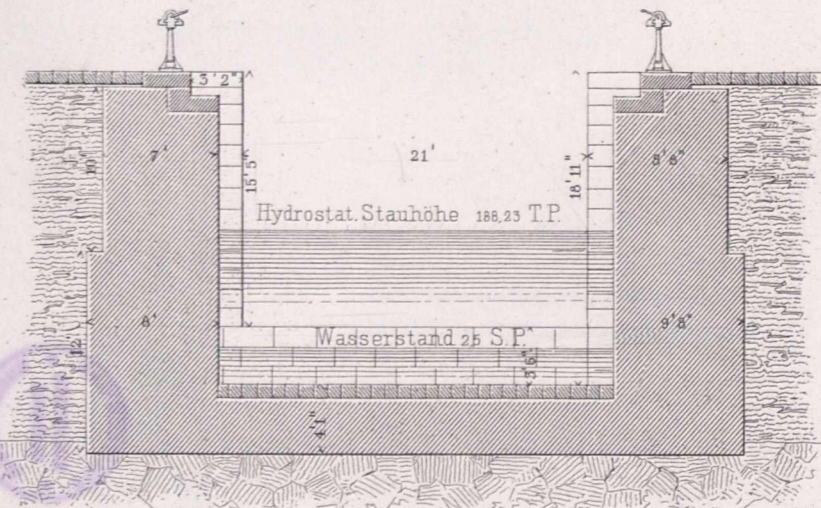

Querschnitt des Oberthores.

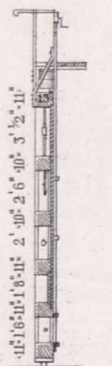

Querschnitt nach c d.

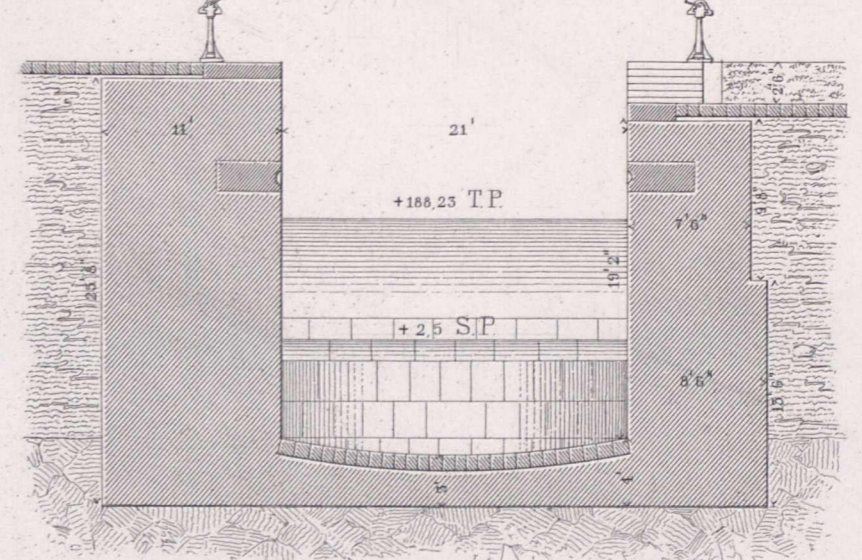

Querschnitt des Unterthores.

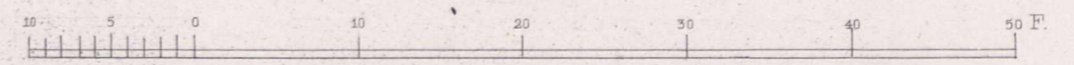
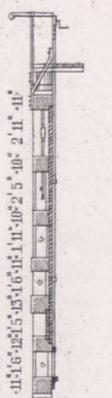

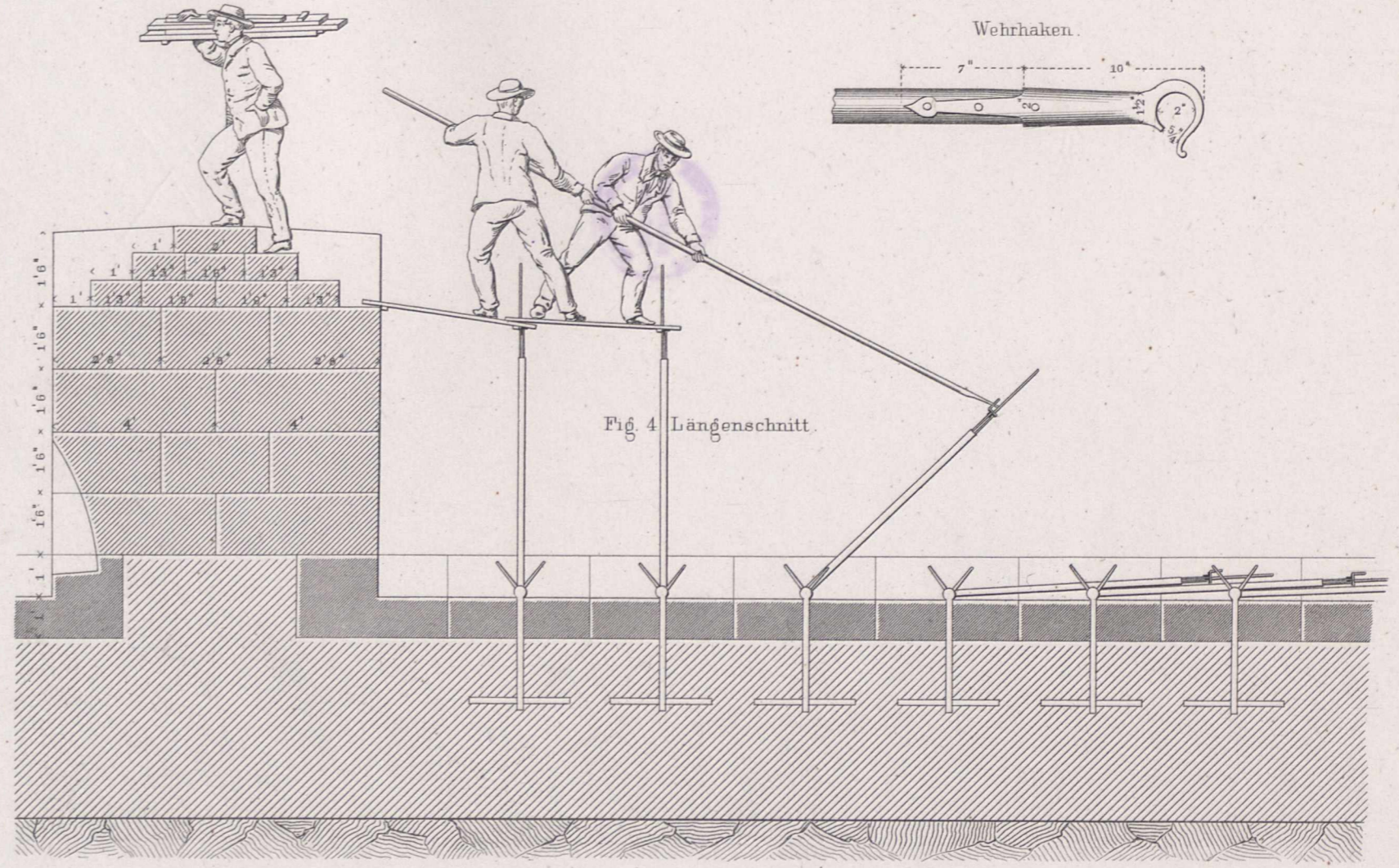
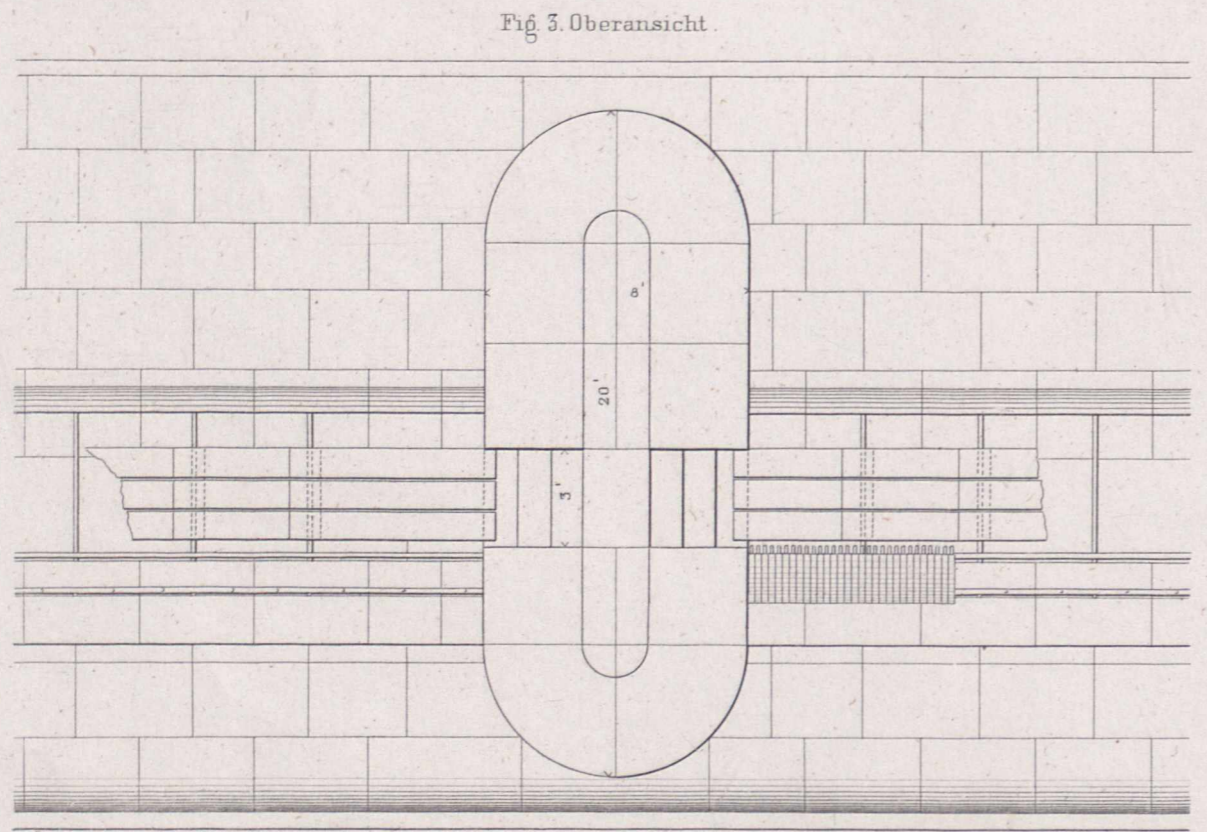
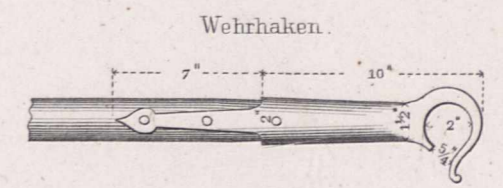
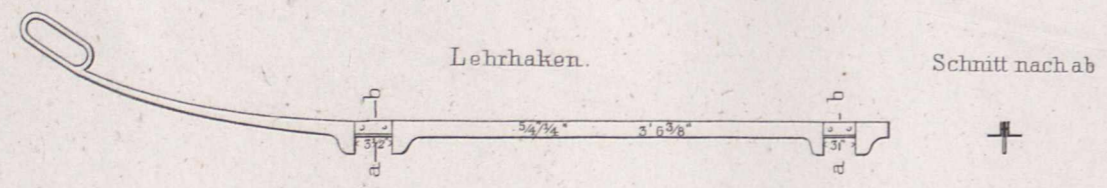
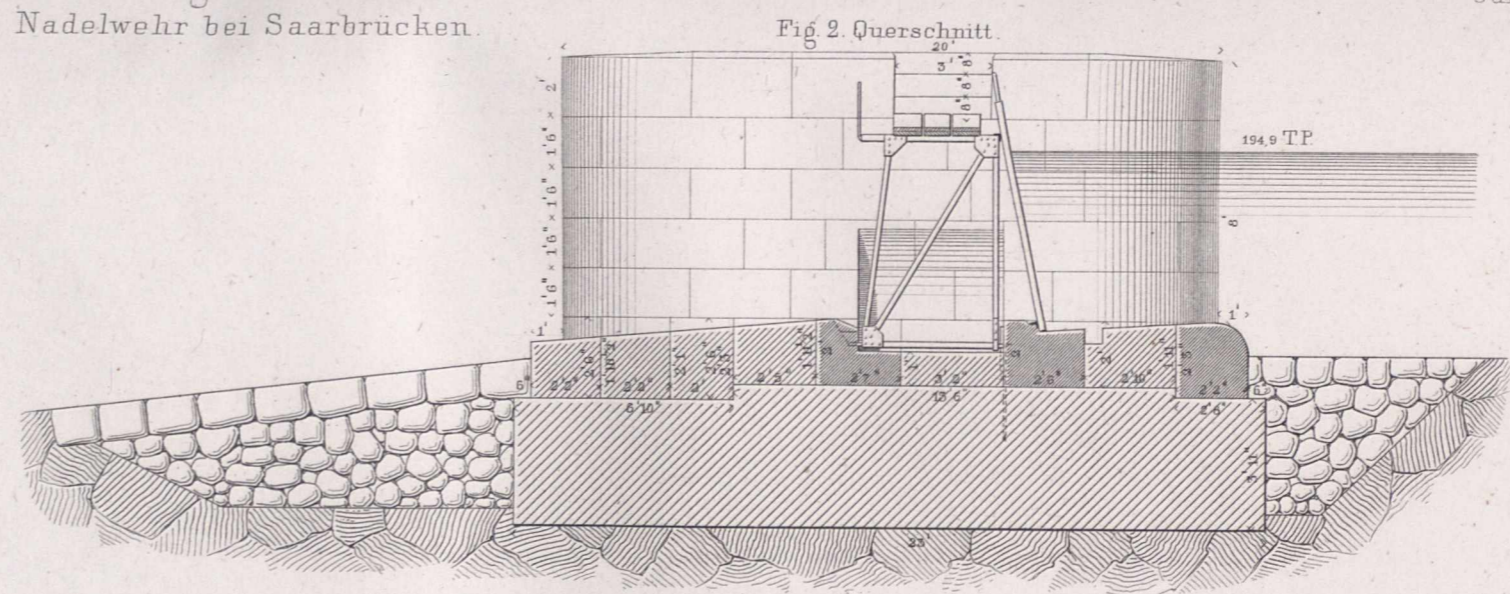
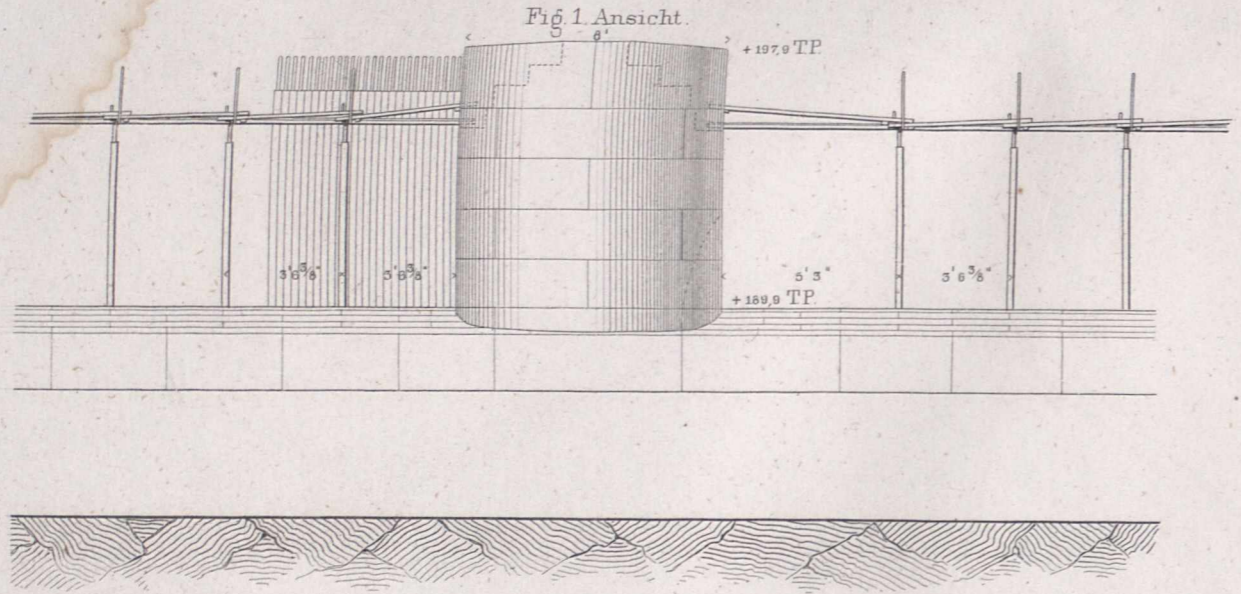

10 5 0 10 20 30 F.  
zu Fig. 1-3.

10 5 0 10 10 F.  
zu Fig. 4.

Vorderansicht  
1:12

Seitenansicht.  
1:12

Schnitt nach ab.  
1:2

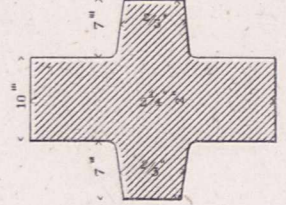
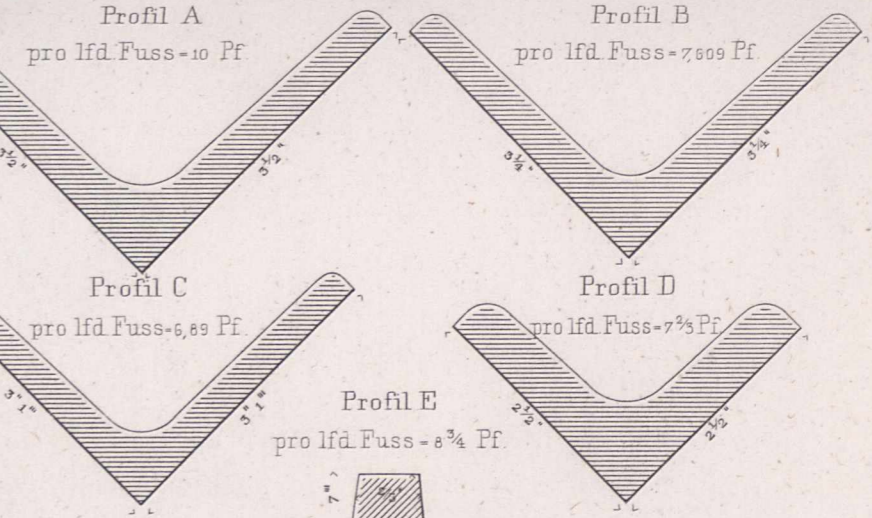

Vorderes Lager bei V.  
1:6

Hinteres Lager bei h.  
1:6

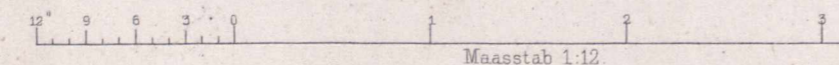
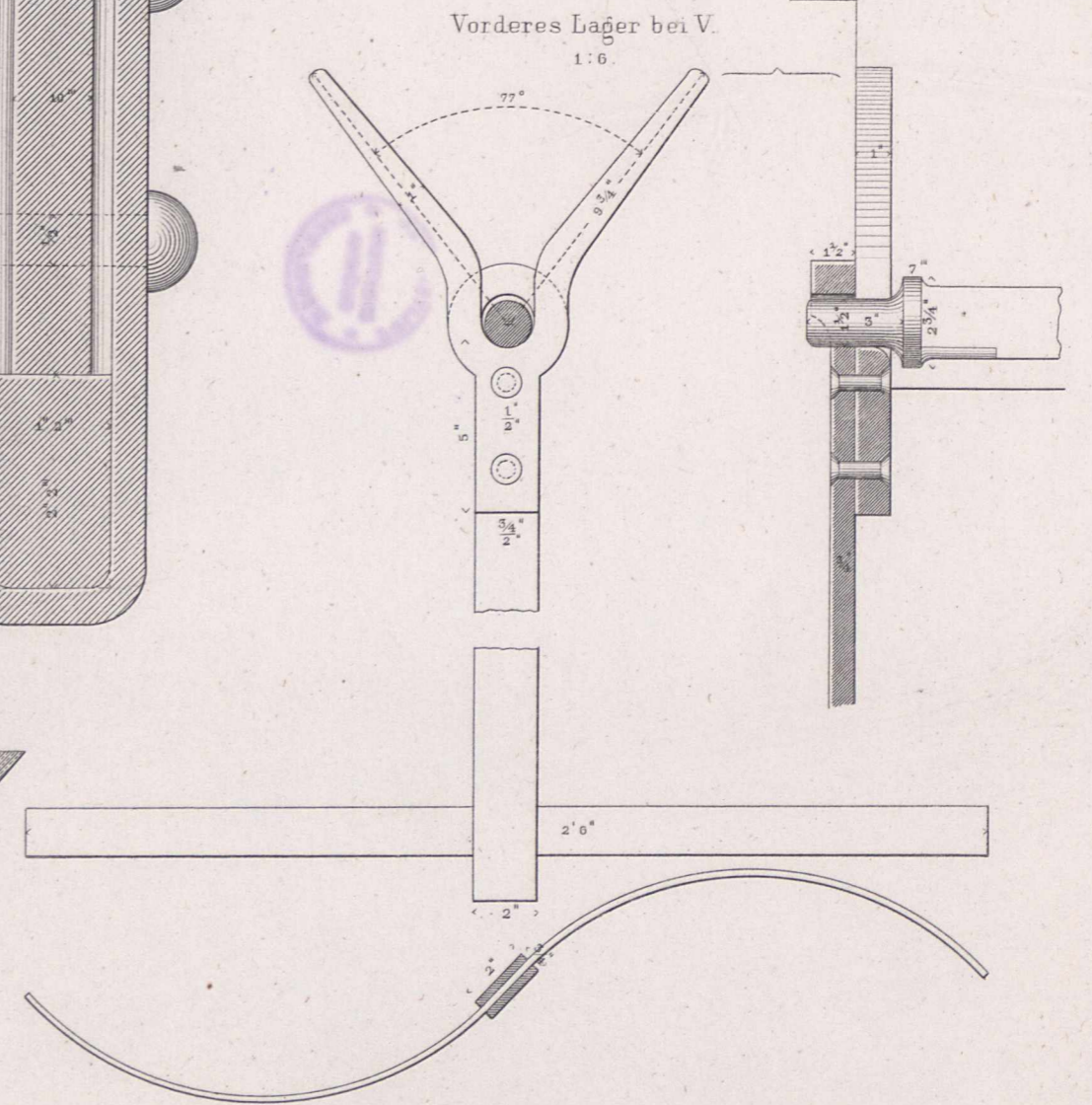
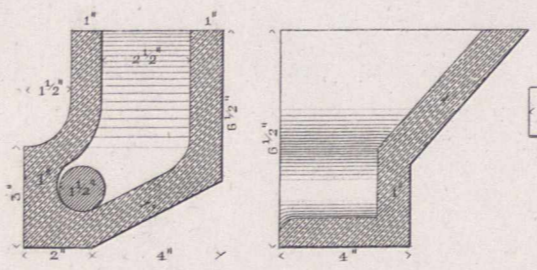
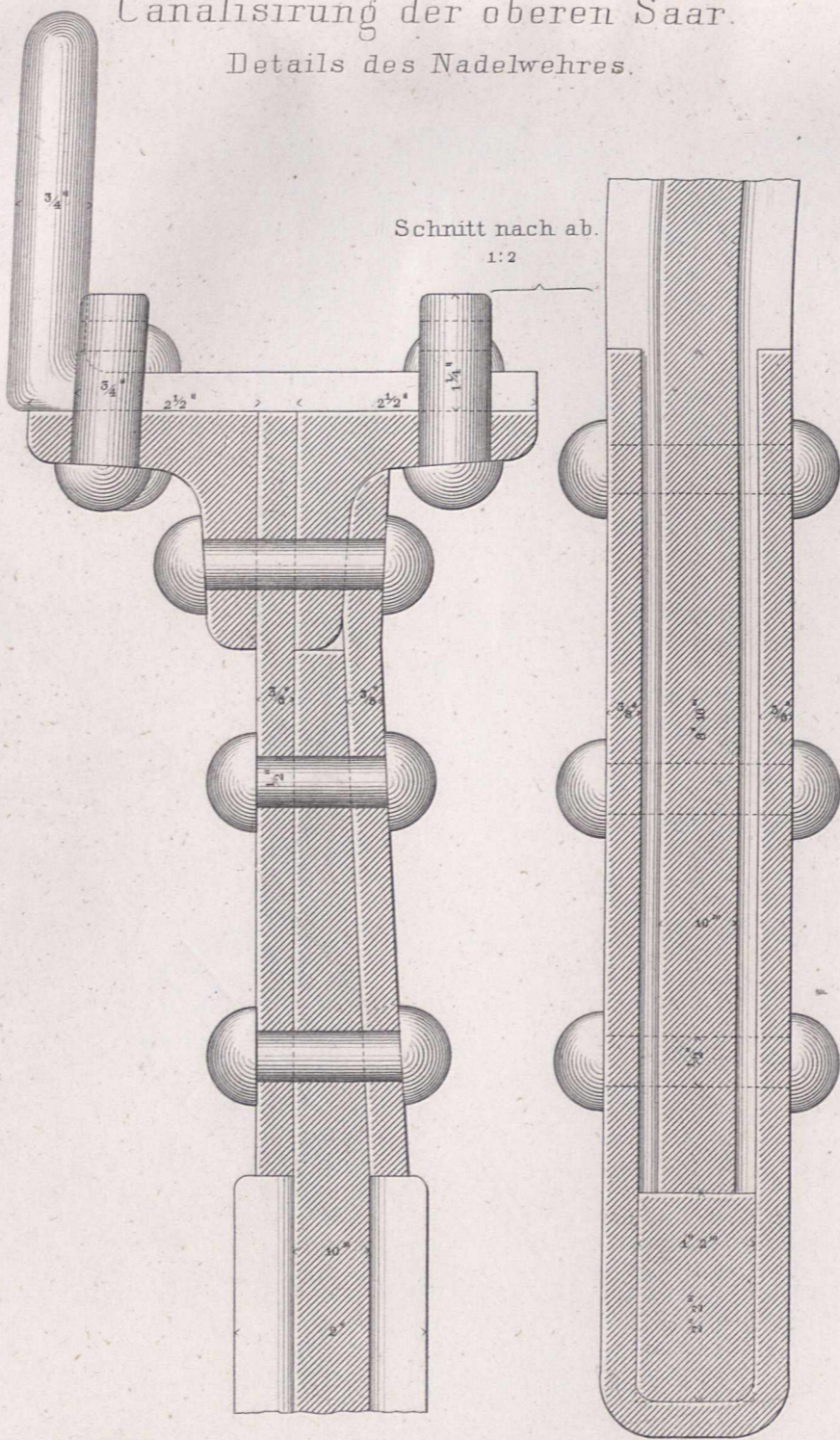
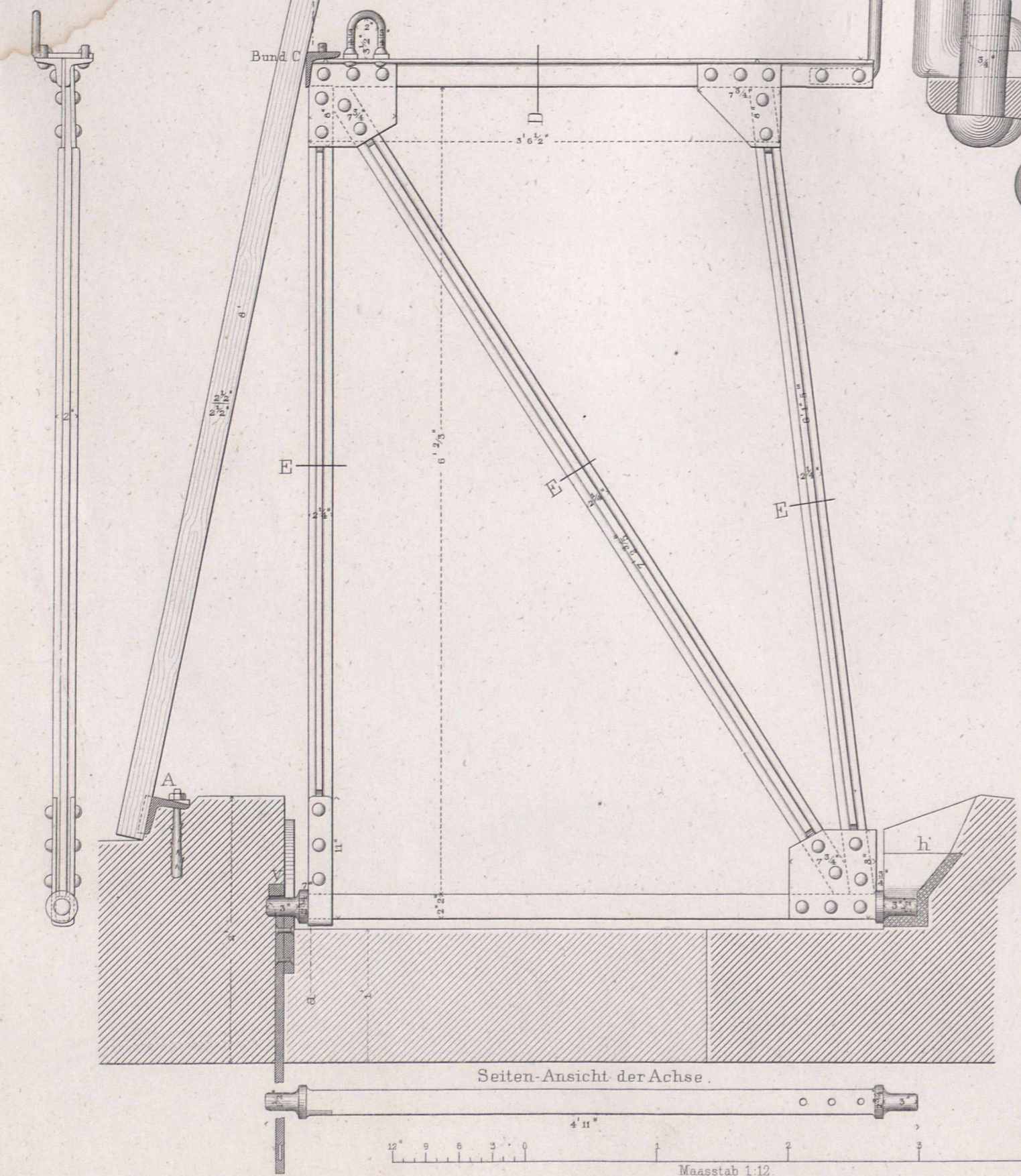

Seiten-Ansicht der Achse.  
4' 11"

Maasstab 1:12

Maasstab 1:6

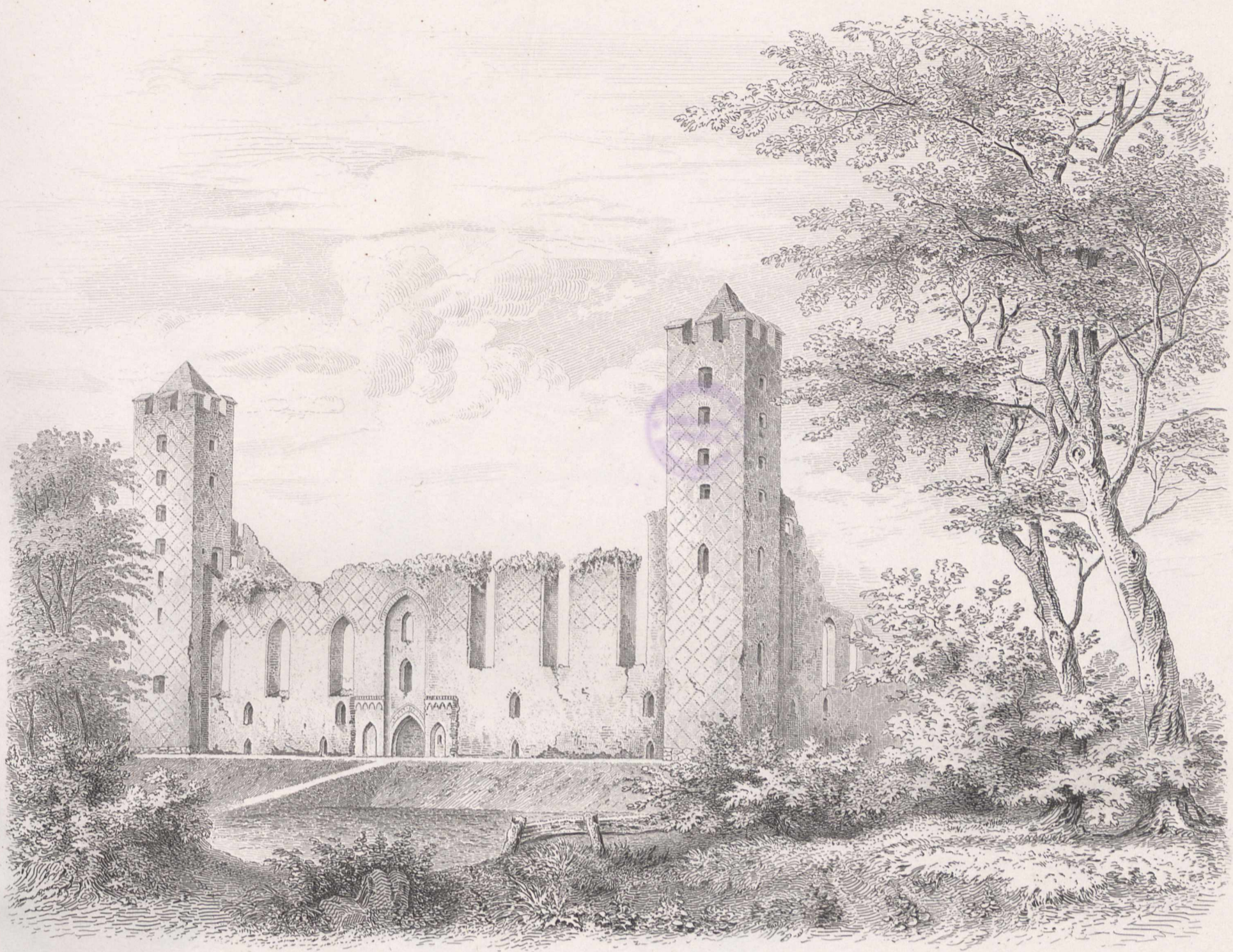

Situations Plan.

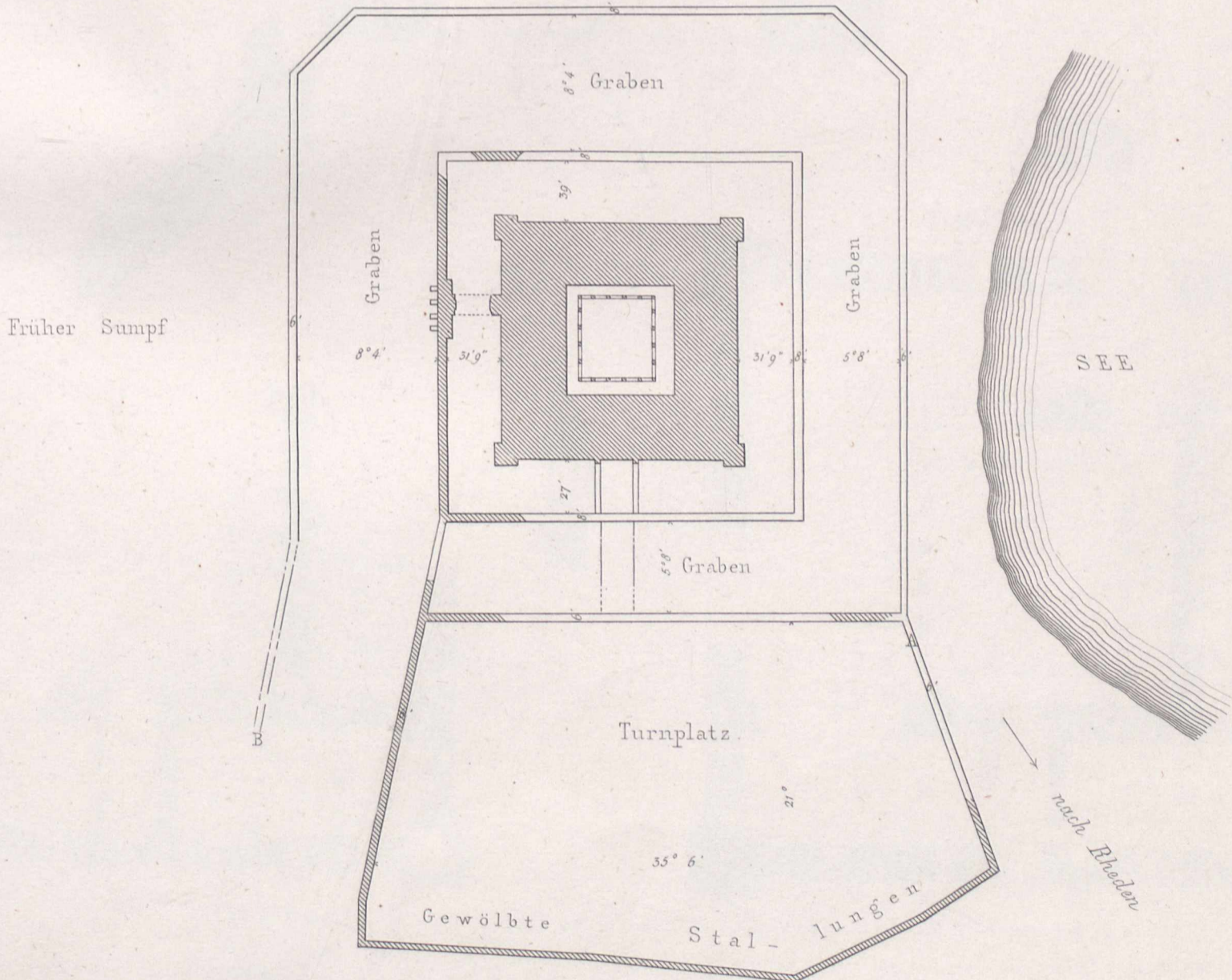

10 0 8 7 6 5 4 3 2 1 0 10 20 Ruthen.

Durchschnitt nach A B.  
Fig. 3.

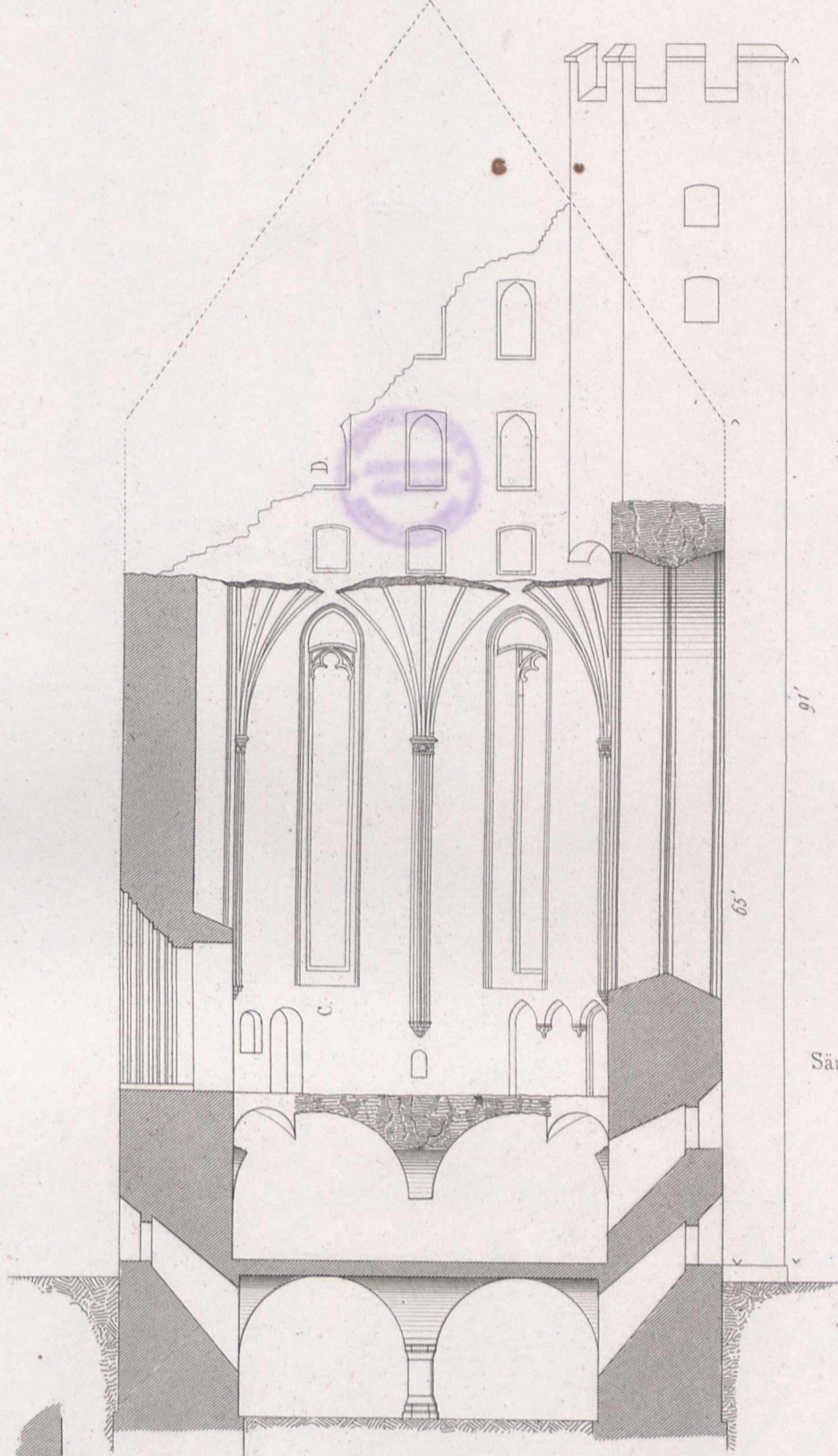

Kapit im Chor der Kapelle  
Fig. 12.

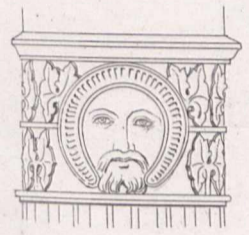

Consol im Rempster Fig. 13.

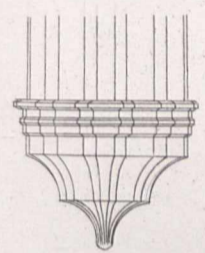

Gewölbegürte

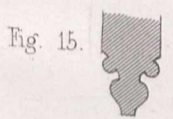
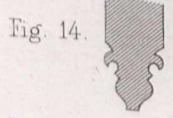

Grundriss.



Fensterprofil.

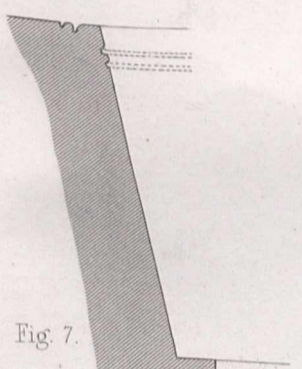

Thürprofil a

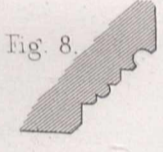

Thürprofil der Kapelle

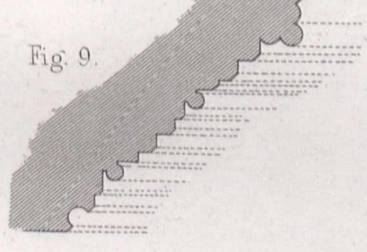

Profil des Haupteinganges.

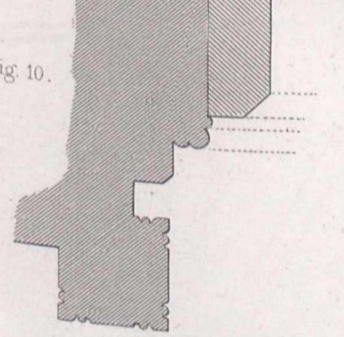

Hauptgeschoss Fig. 2.

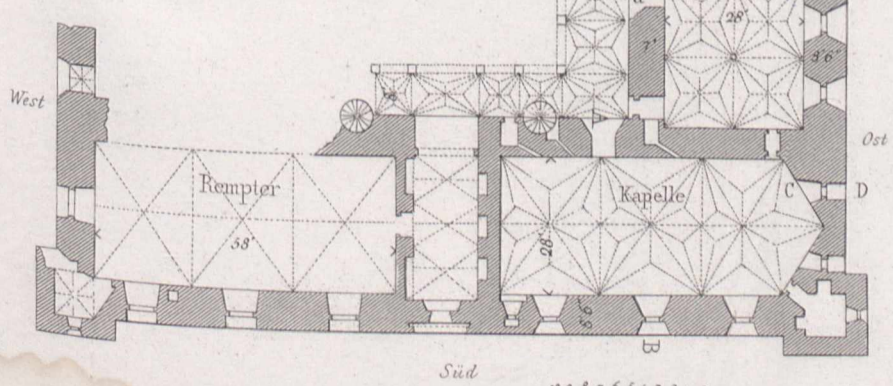

Dienste in der Kapelle  
Fig. 11.

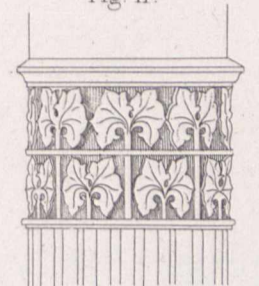

Durchschnitt C.D.  
Fig. 4.

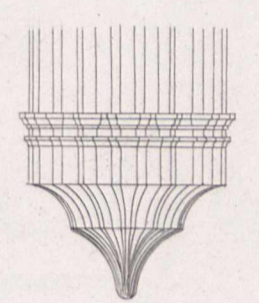
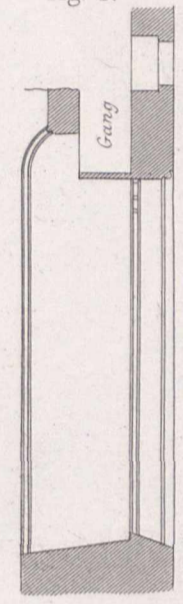

Grundriss.



Säule im Keller unter E. Fig. 5. Säule im Keller unter G. Fig. 6.

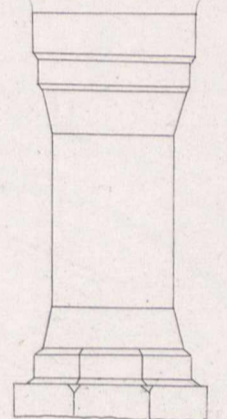
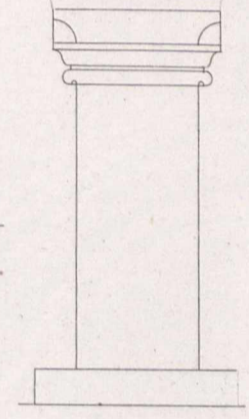

Erdgeschoss Fig. 1.

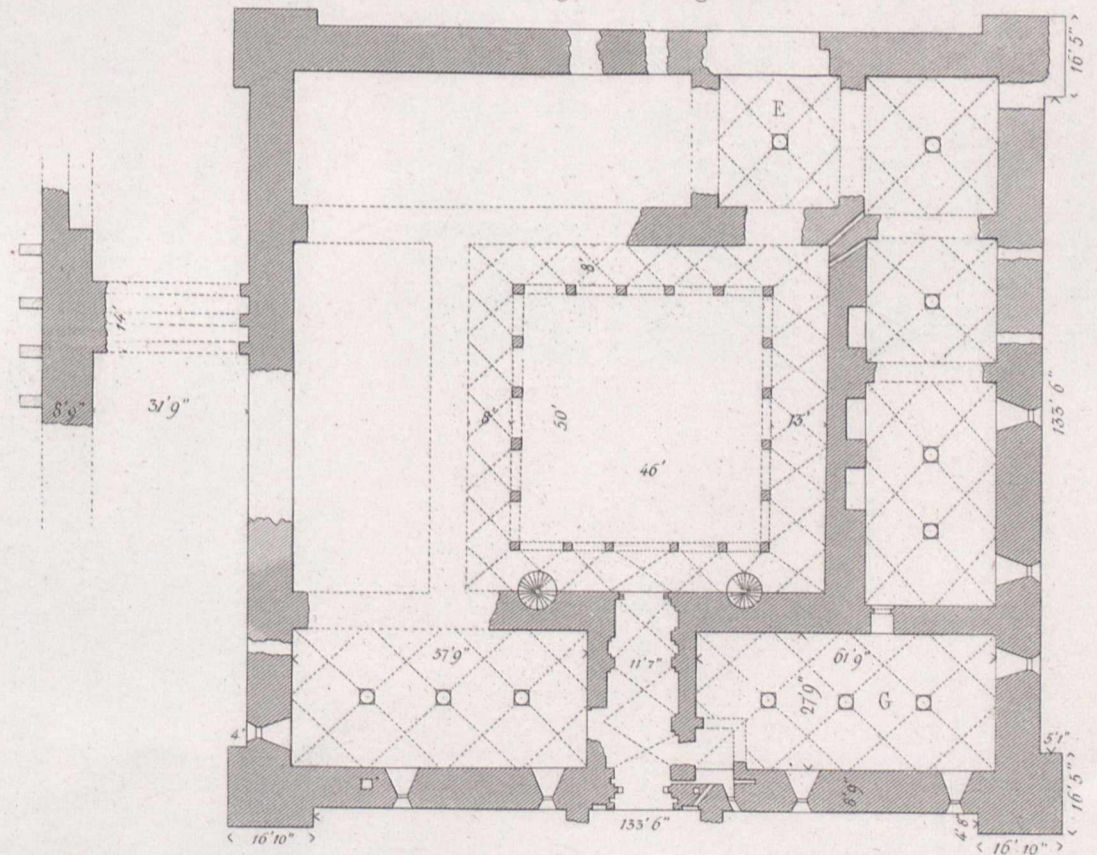

10 9 8 7 6 5 4 3 2 1 0 10 20 30 40 50 60 70 80 90 100 200 Fuss  
50 Fuss Durchschnitt Fig. 3-4.  
200 Fuss Grundrisse Fig. 1-2.  
10 Fuss Profile Fig. 4 bis 10.  
1 Fuss Fig. 11 bis 15.



Unterspree - Brücke  
in der

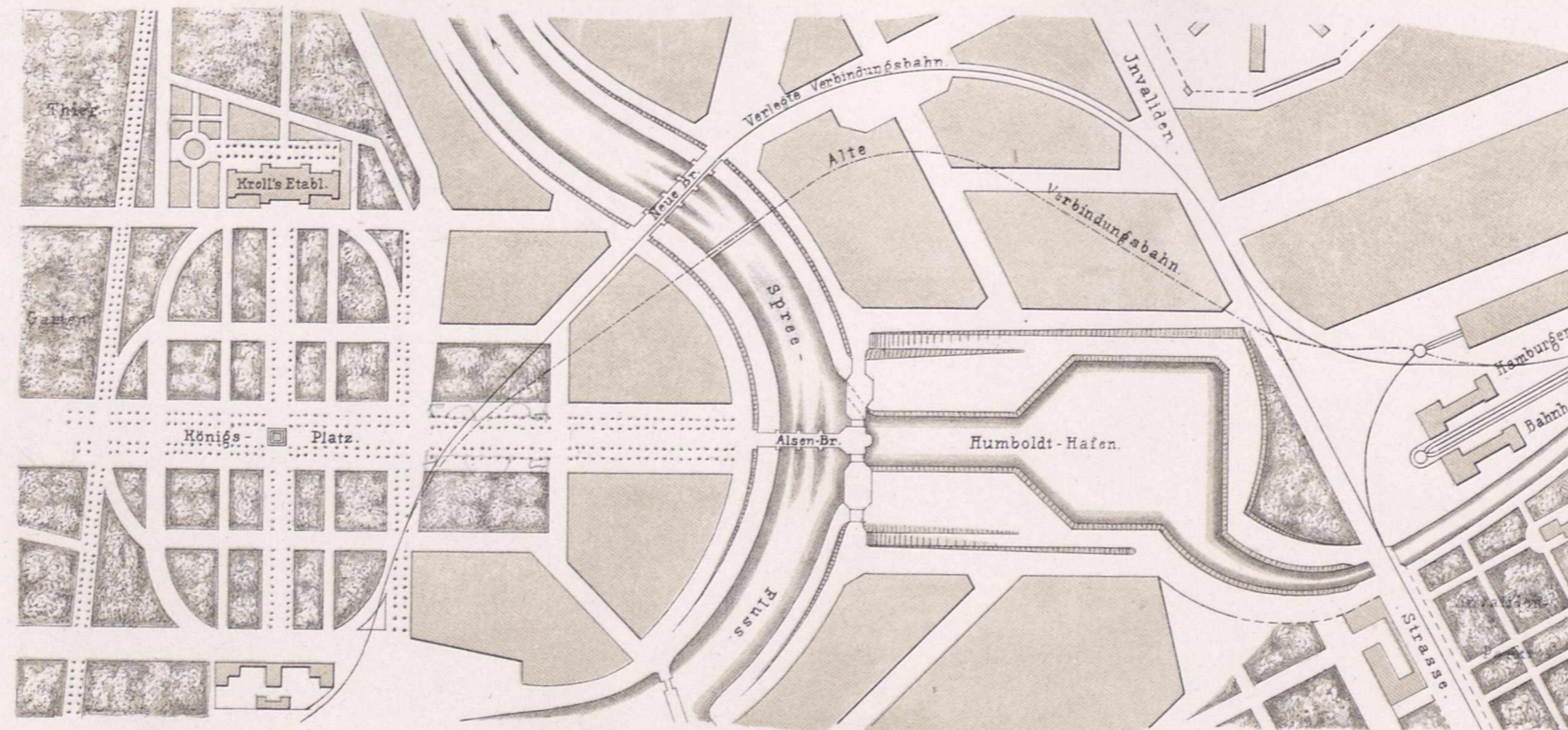

Bahnhofs - Verbindungsbahn  
zu Berlin.





Fig. 2. Querschnitt nach A B in Fig. 2. auf Bl. 39.

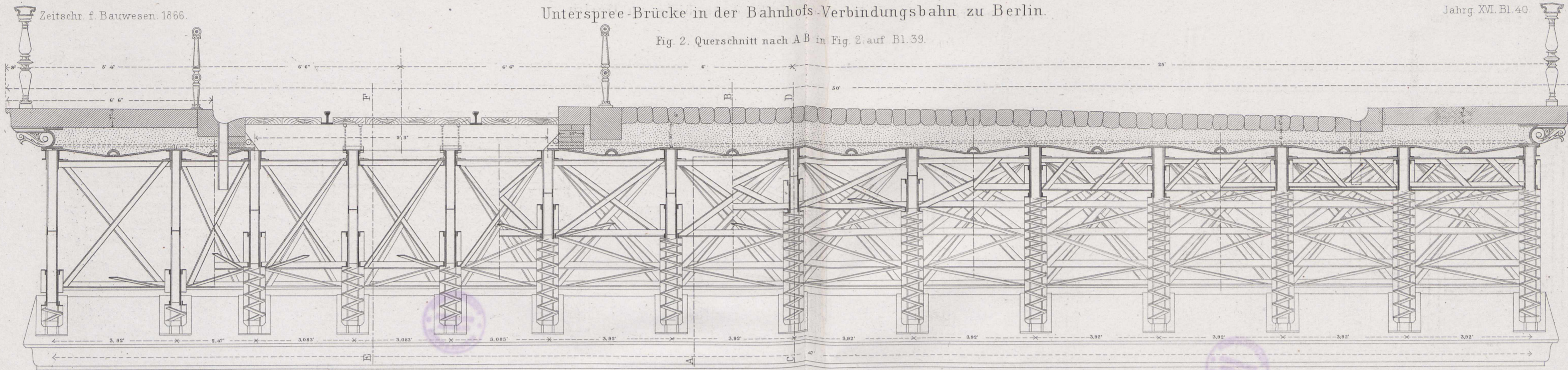

nach C D (Fig. 2.)

Fig. 1. Längenschnitt.

nach A B (Fig. 2.)

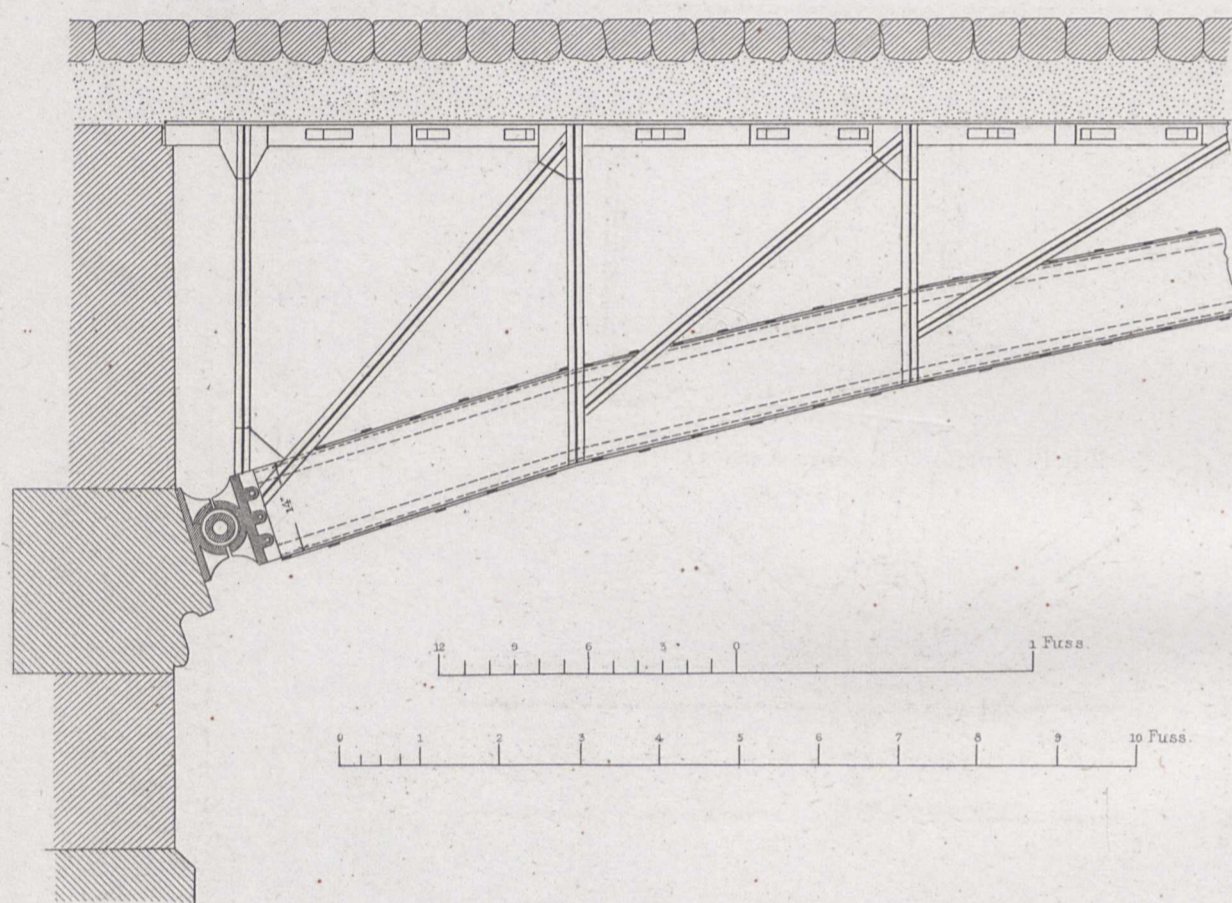

Fig. 4. Ansicht von oben.

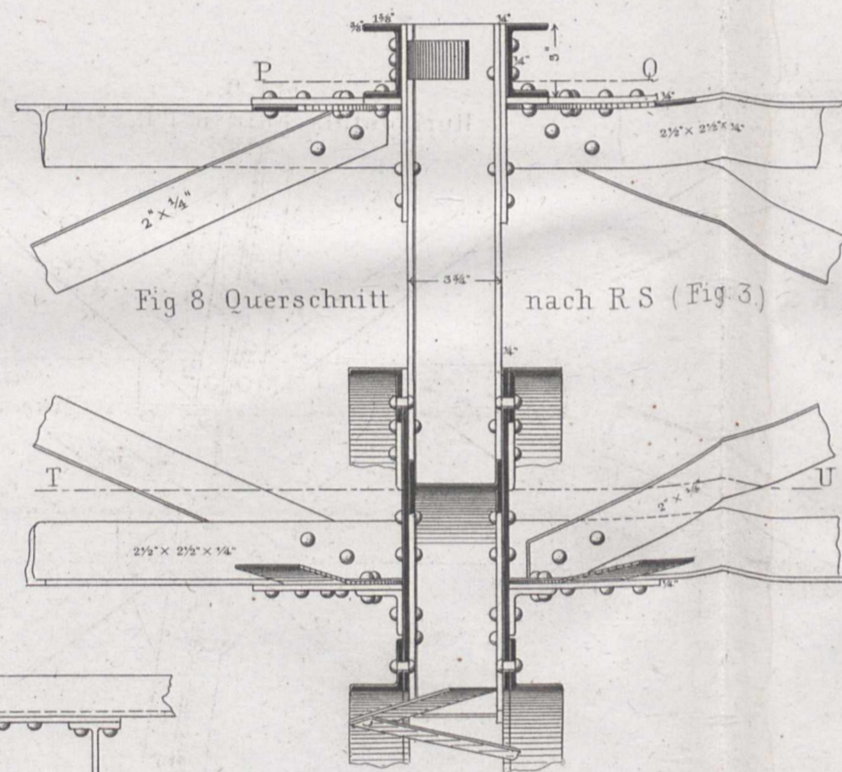

Fig. 8 Querschnitt

nach R S (Fig. 3)

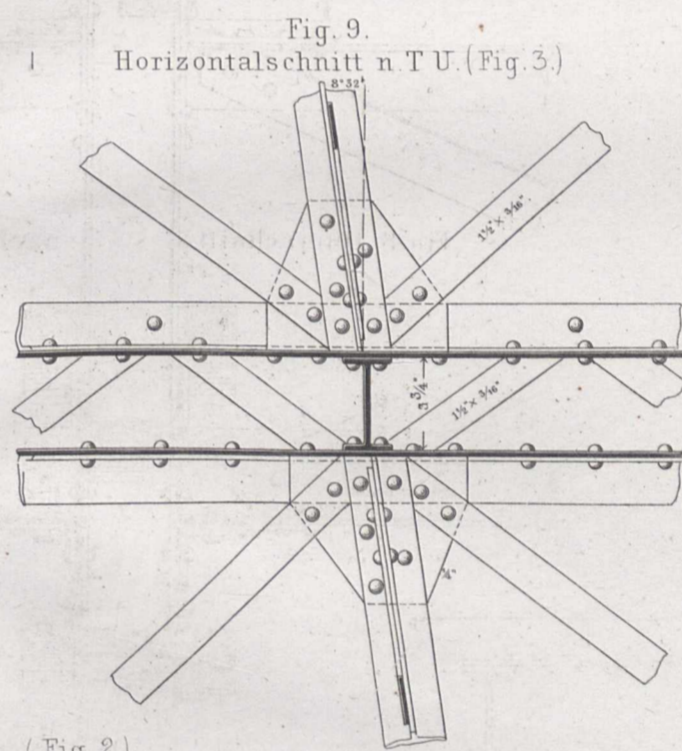

Fig. 9. Horizontalschnitt n T U (Fig. 3)

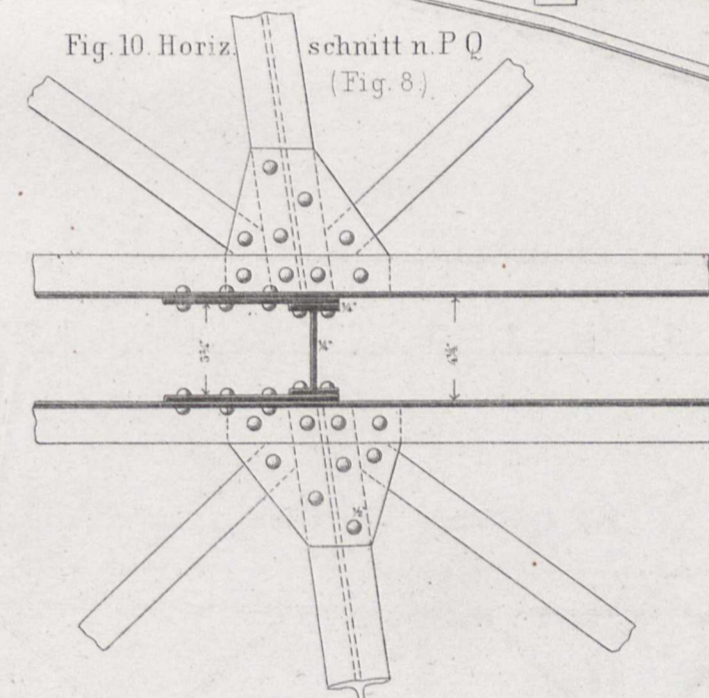

Fig. 10 Horiz. schnitt n P Q (Fig. 8)

Fig. 3\* Querschnitt nach A B (Fig. 2)

Fig. 3. Seitenansicht.

Fig. 3\* Schnitt nach V W

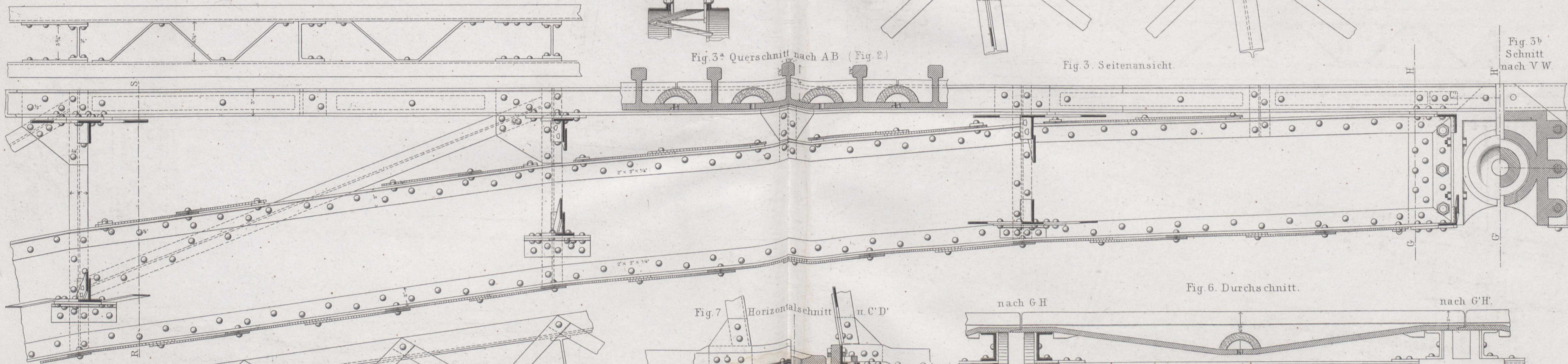

Fig. 5. Ansicht von unten.

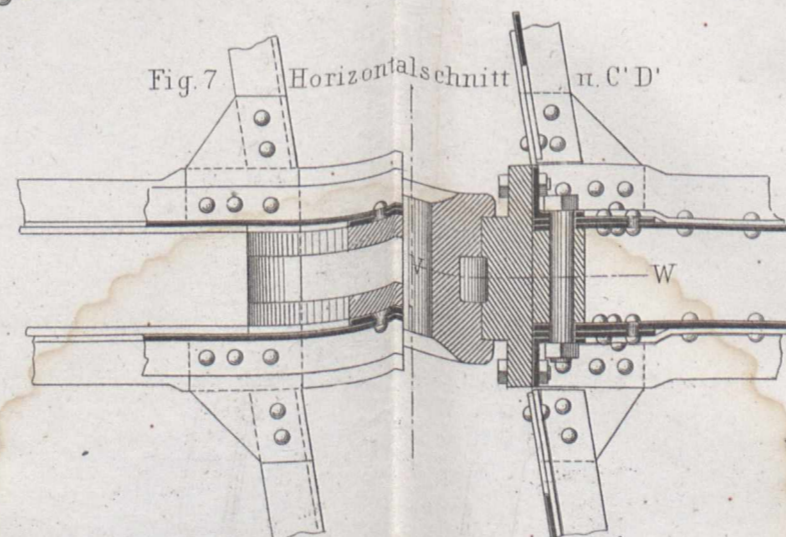

Fig. 7 Horizontalschnitt n C' D'

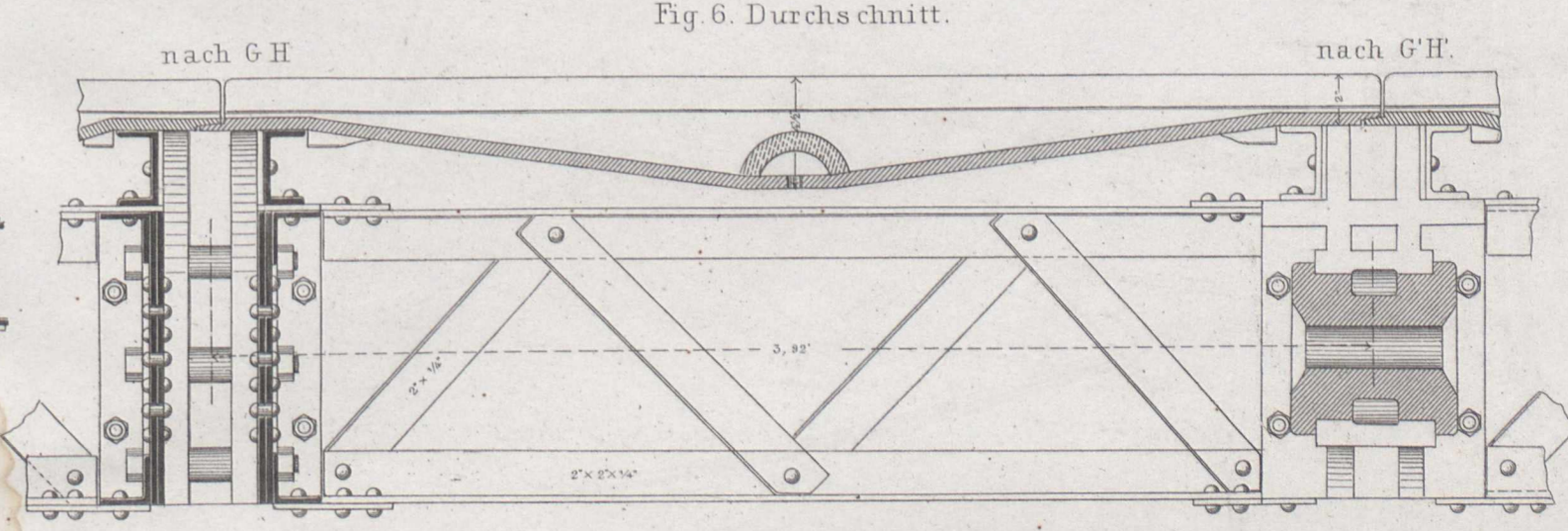

Fig. 6. Durchschnit. nach G H.

Fig. 1. Längenschnitt nach EF (in Fig. 2 auf Bl. 40).

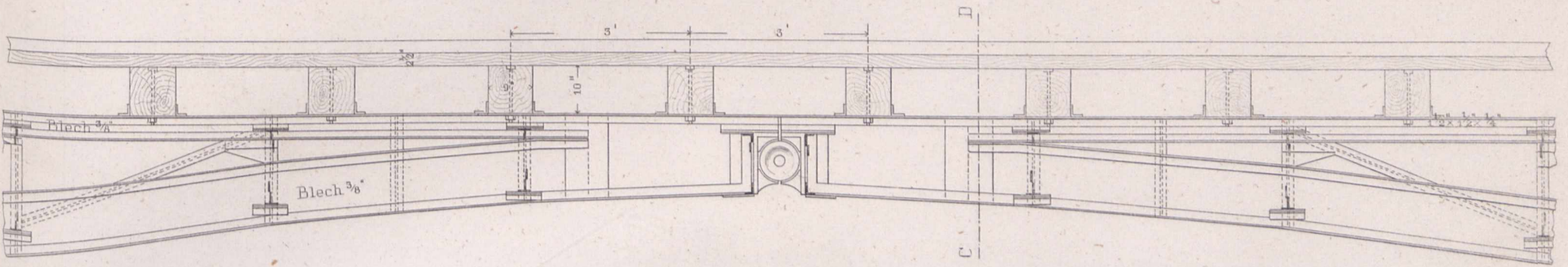

Fig. 2. Seitenansicht des Widerlager-Bolzens.

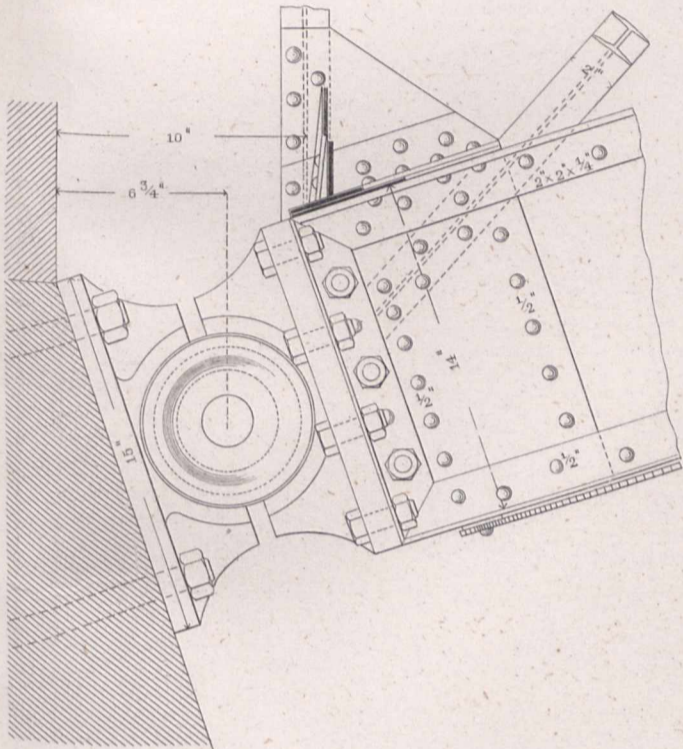

Fig. 3. Längenschnitt nach JK (Fig. 5).

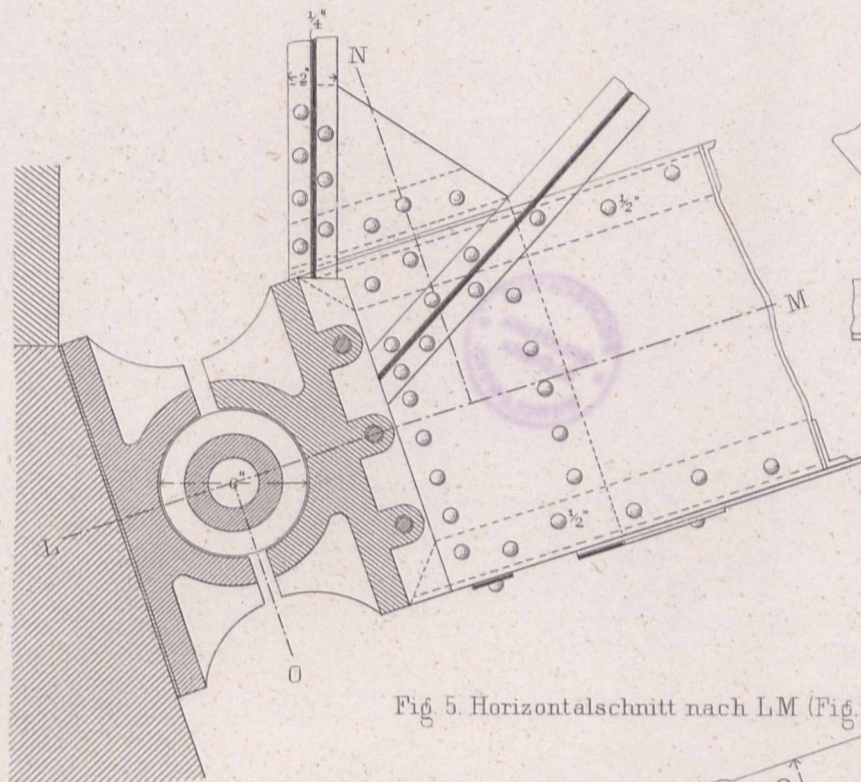

Fig. 4. Querschnitt n. NO (Fig. 3).

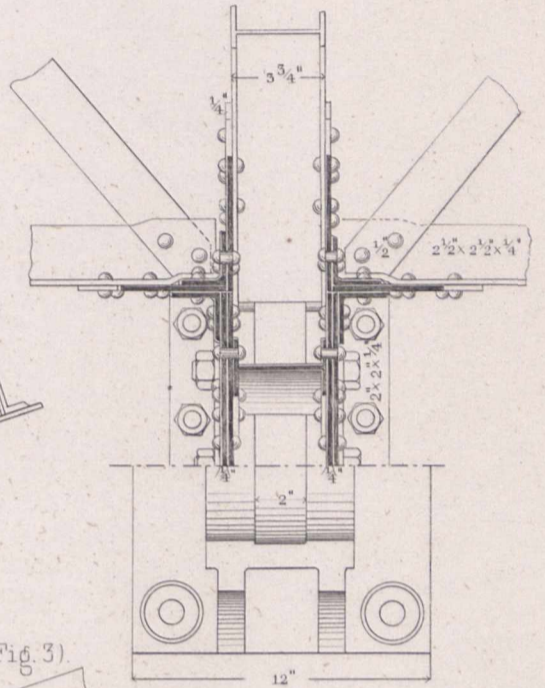

Fig. 5. Horizontalschnitt nach LM (Fig. 3).

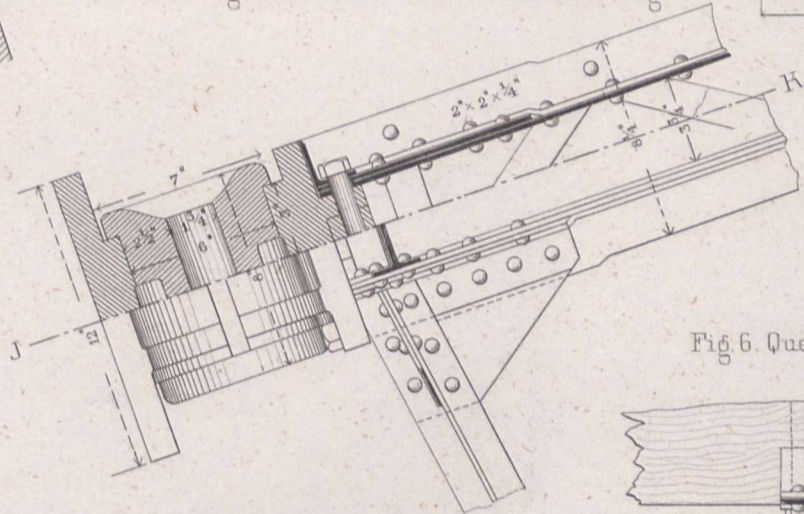

Fig. 7. Unteransicht der Belagsplatte.

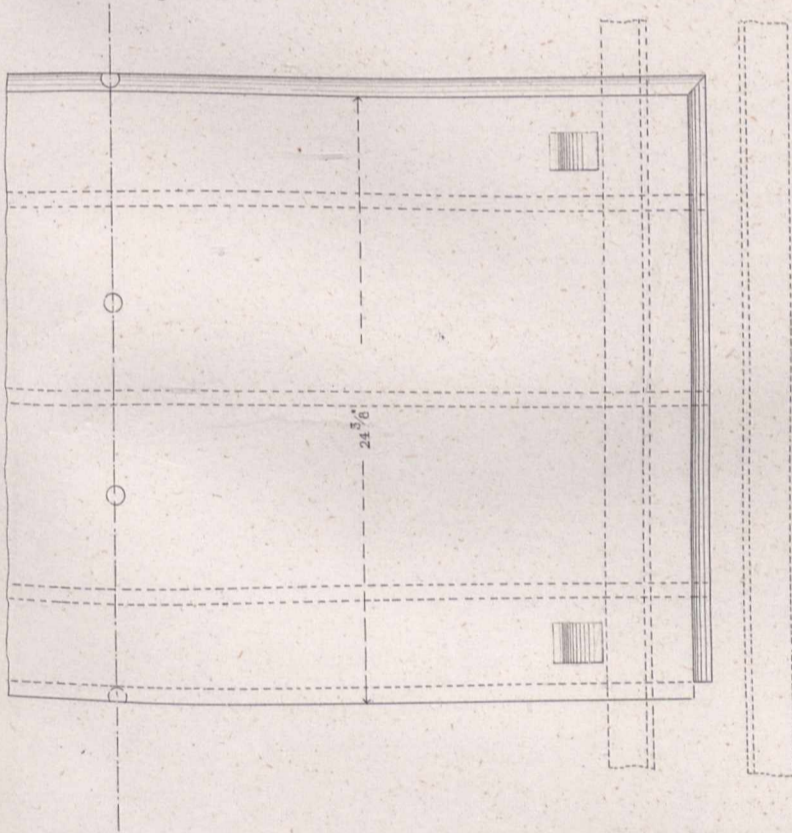

Fig. 6. Querschnitt nach CD (Fig. 1).

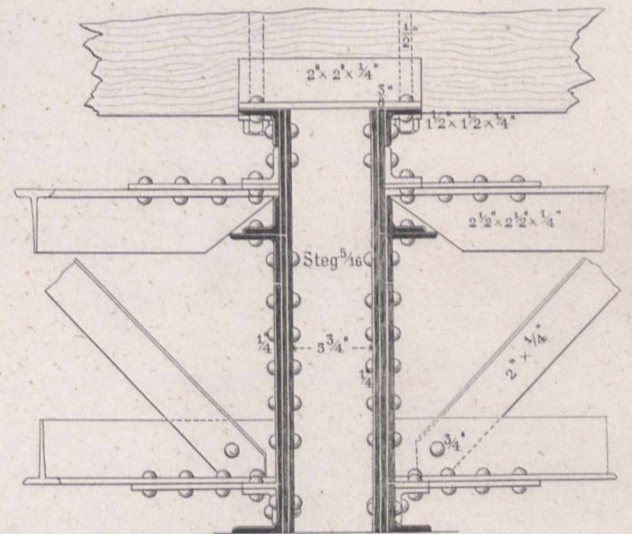
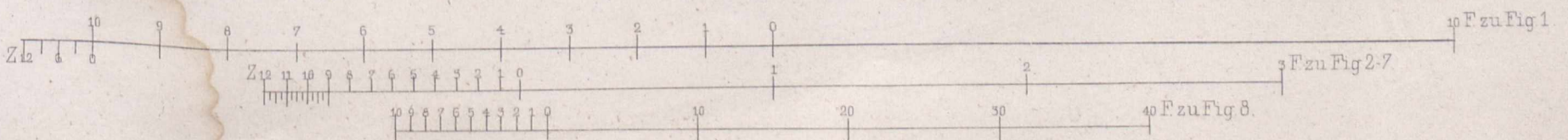
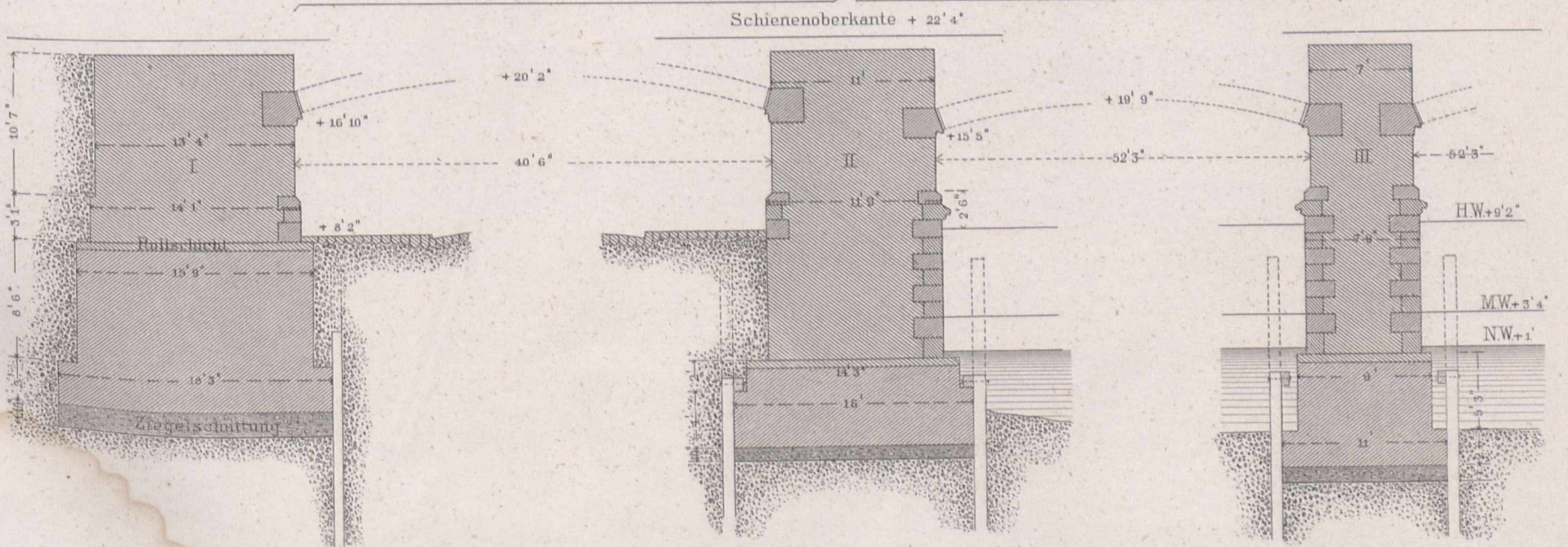
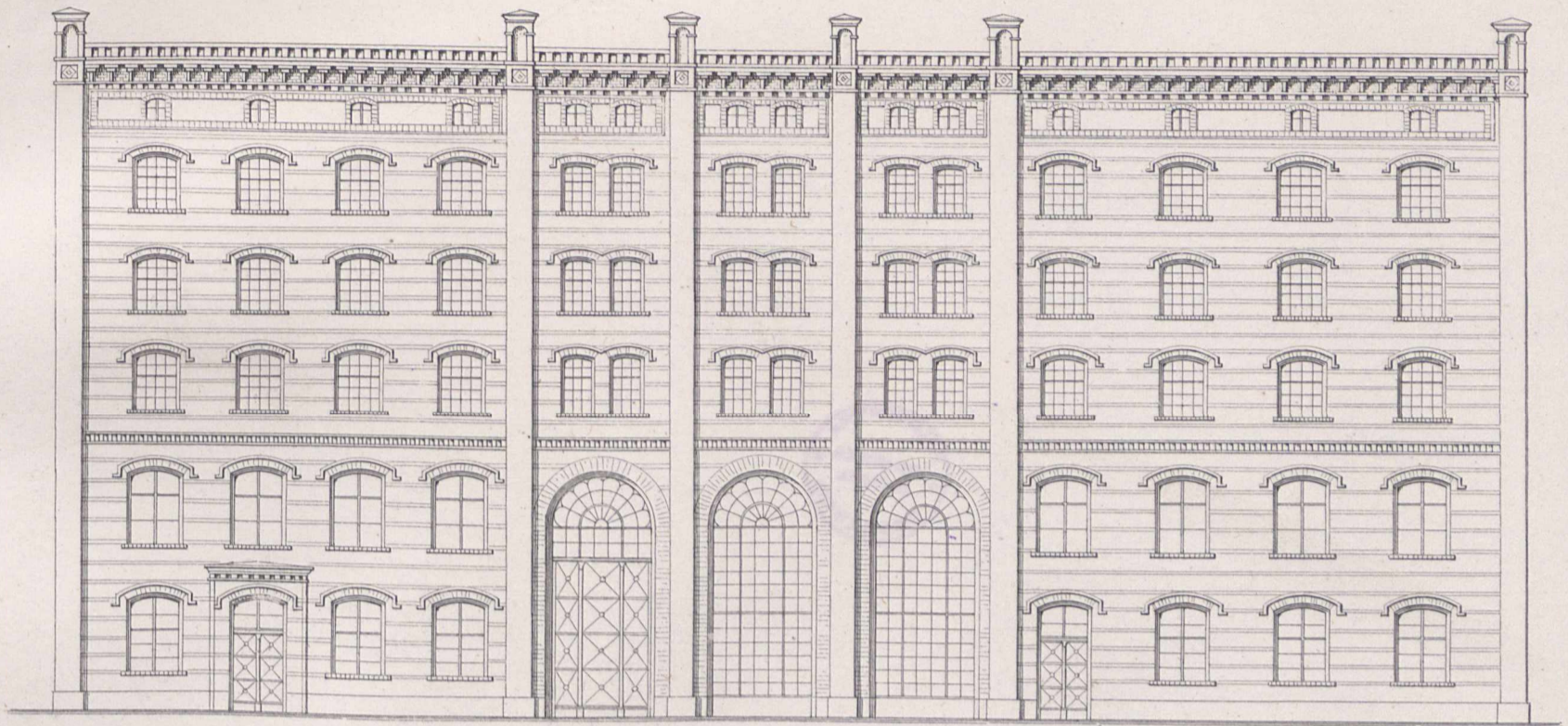

Fig. 8. Querprofile der Pfeiler.





Ansicht.

Durchschnitt nach AB.

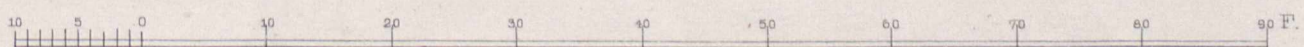
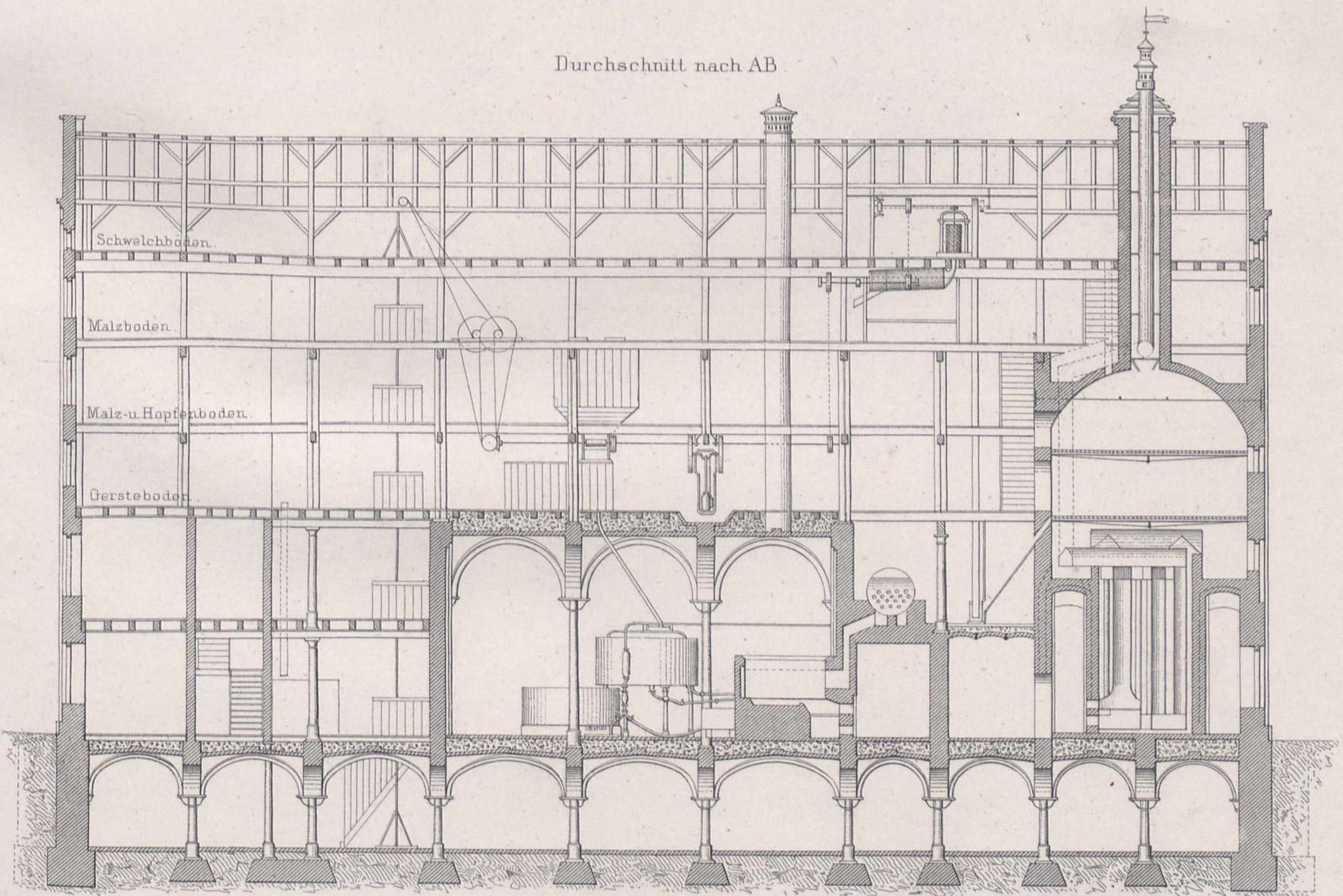

Durchschnitt nach CDE.

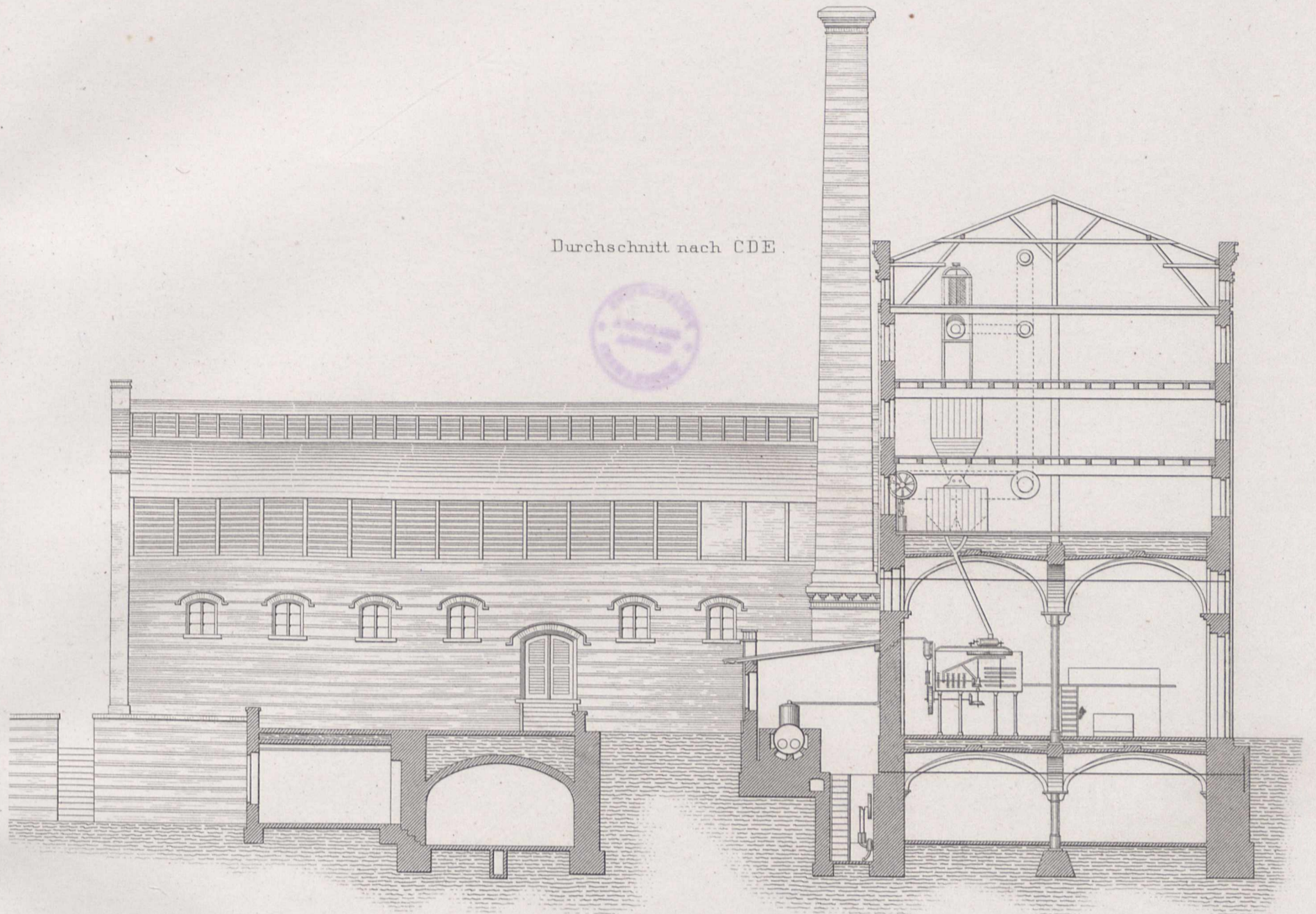

Grundriss der (Malz-u. Schänkbier) Keller.

Grundriss des Erdgeschosses.

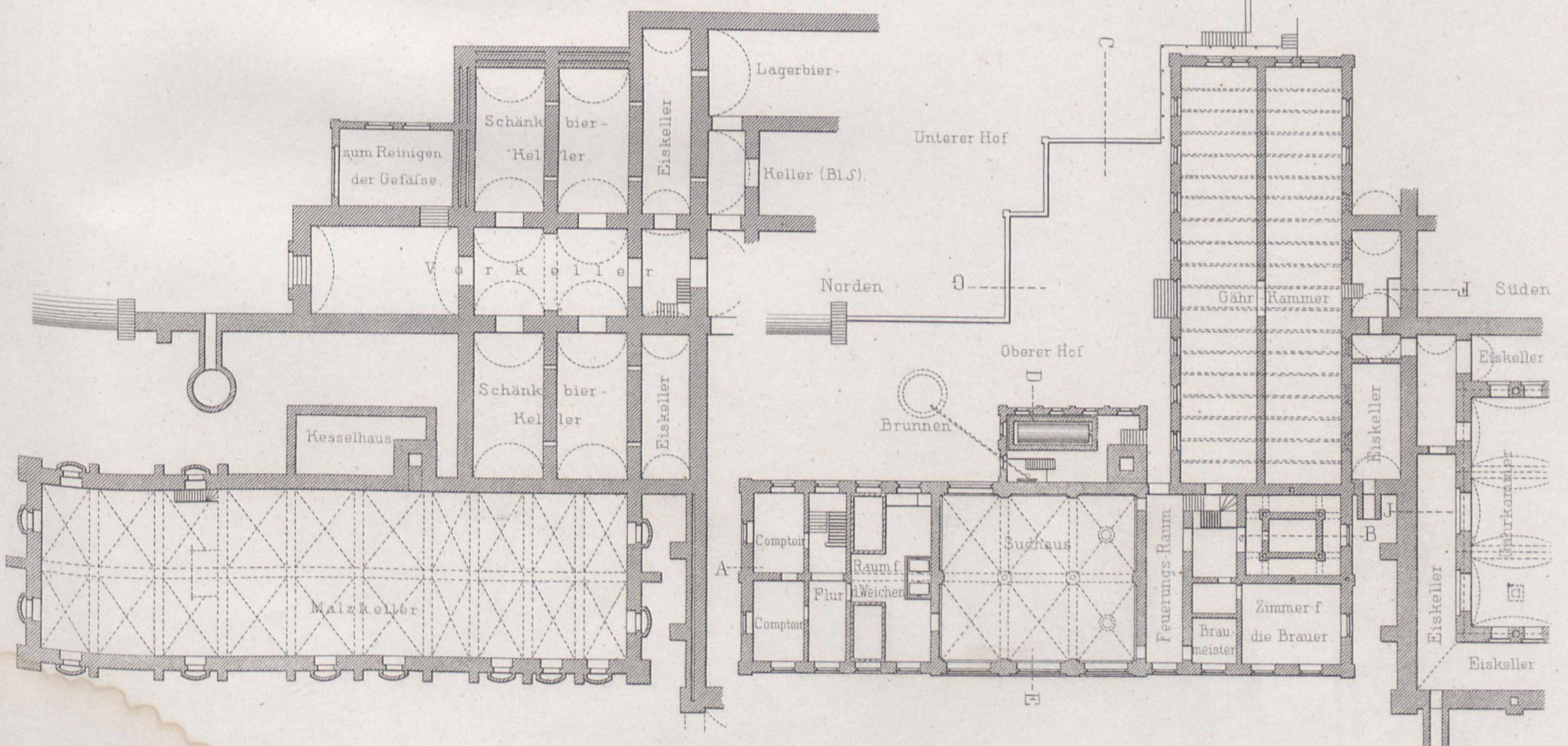

Ernst & Korn. Berlin.

Walther gest.

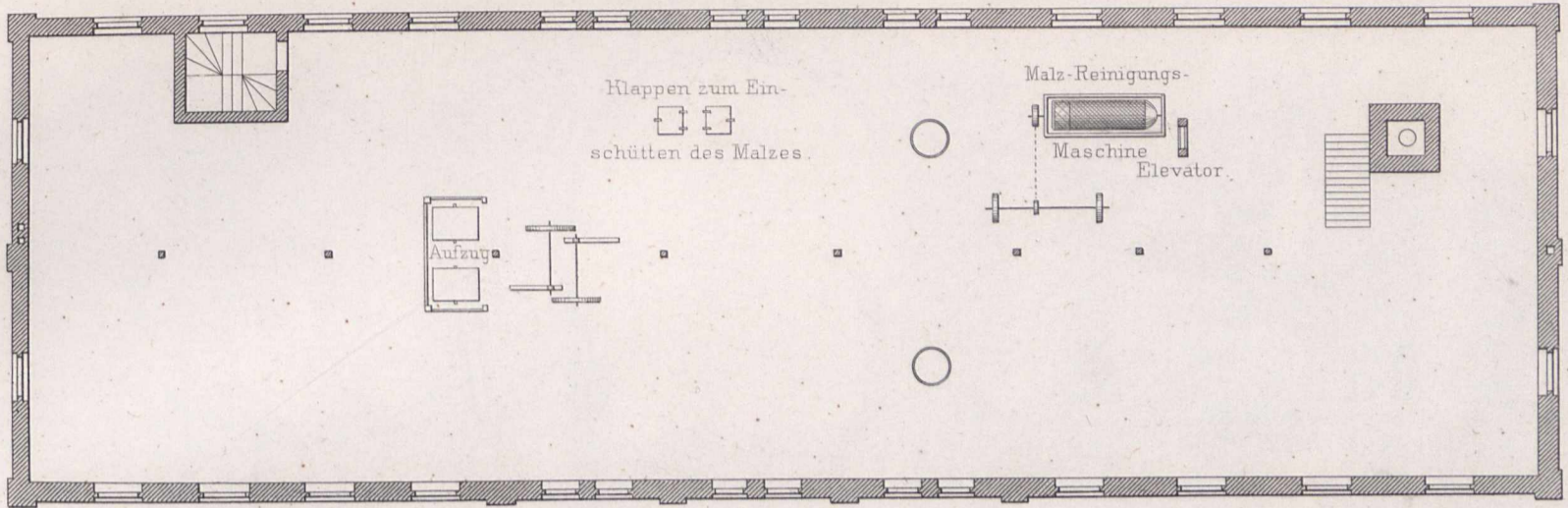

IV. Etage (Malzboden).

Durchschnitt nach F'G.

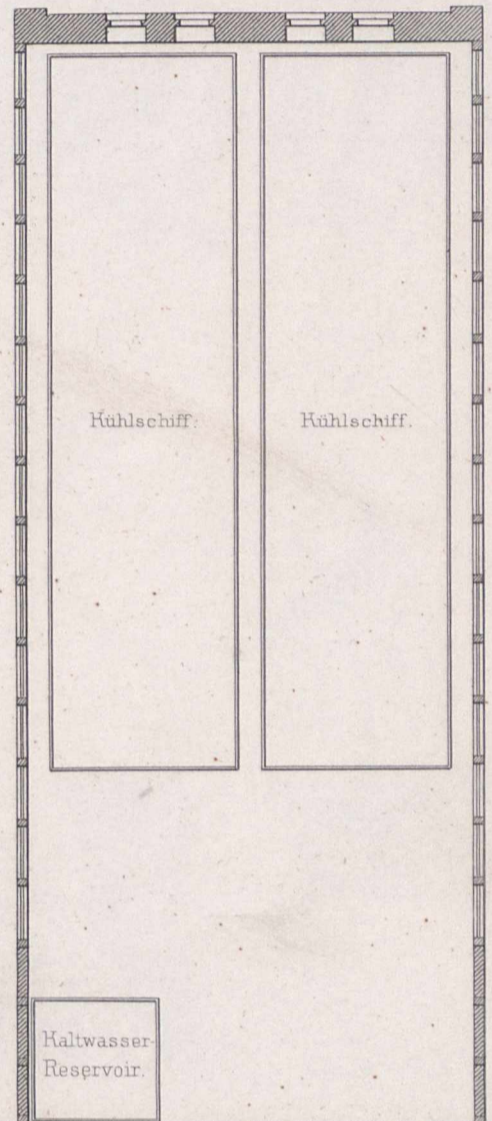
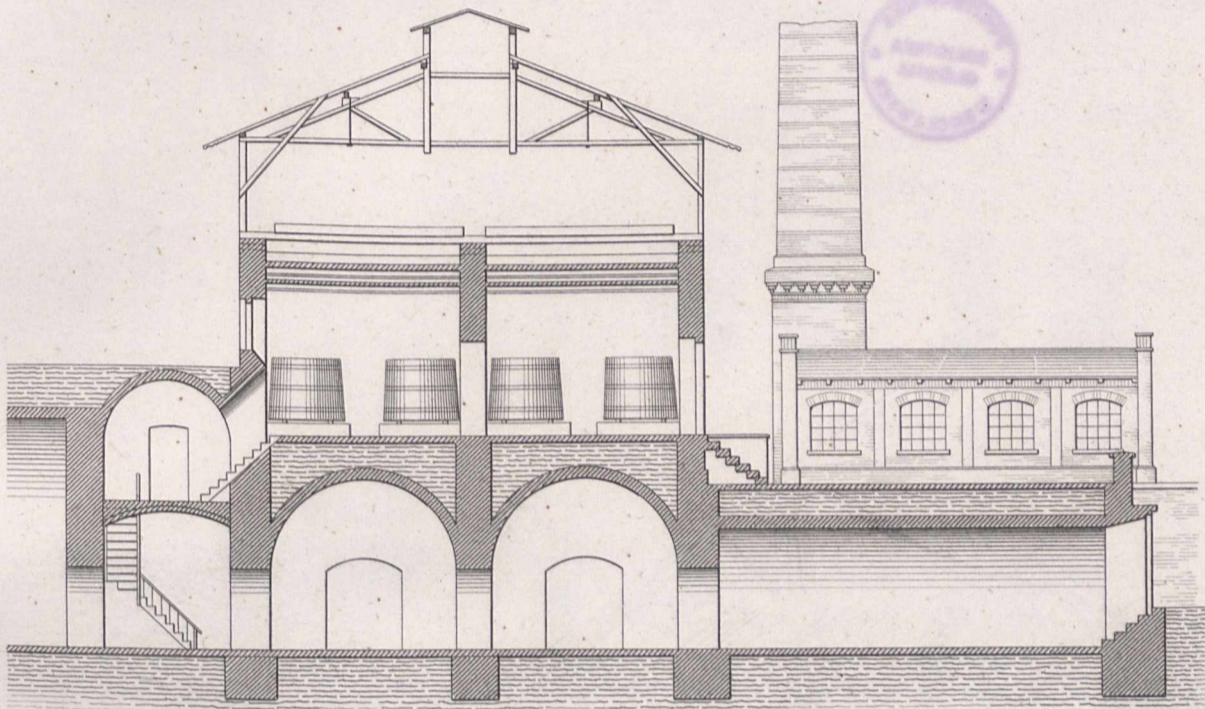

II. Etage (Gersteboden).

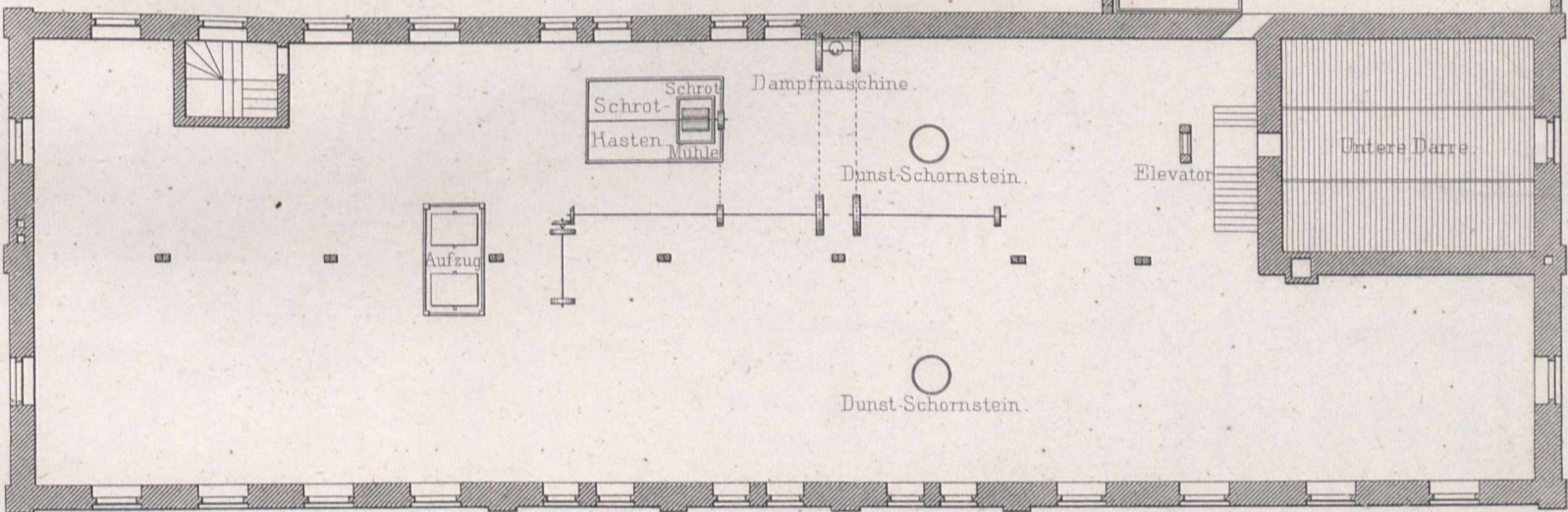

I. Etage.

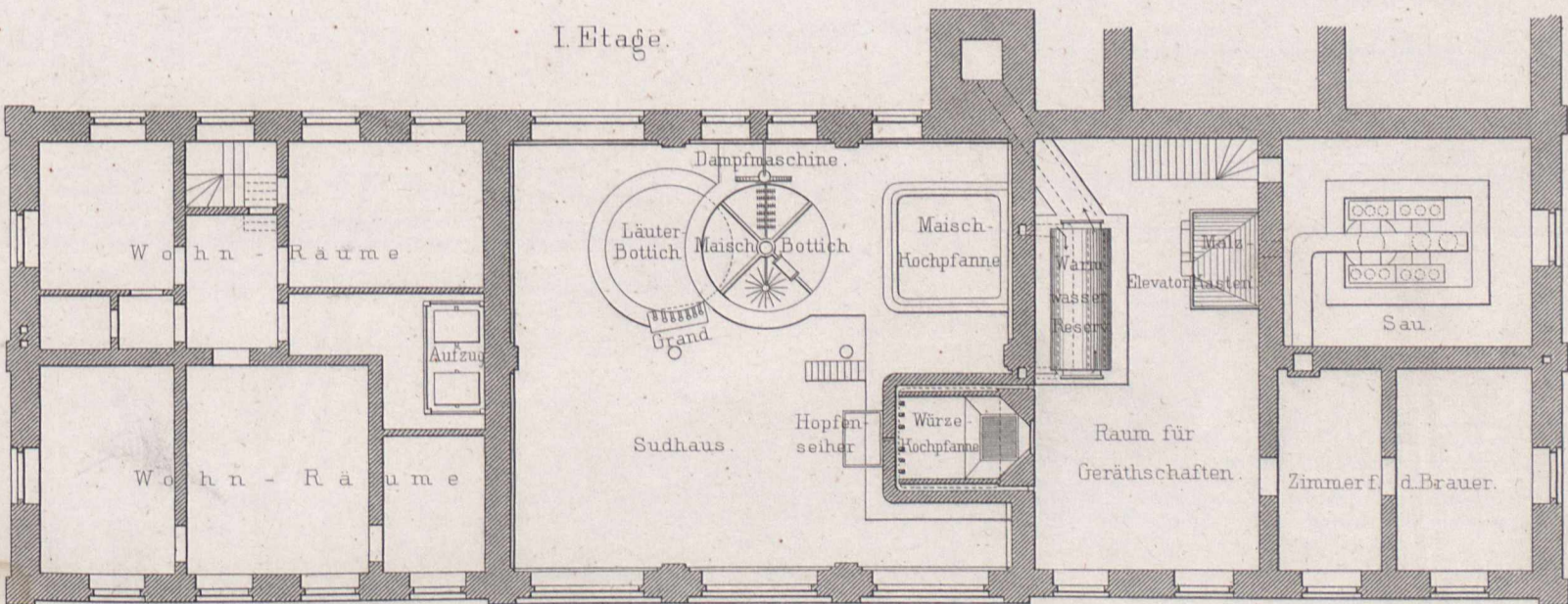

0 5 10 20 30 40 50 60 70 80 90 100 F. rhd.



Ammān Thor ( Bab'el Ammān ) in Gerasa.

Grundriss.

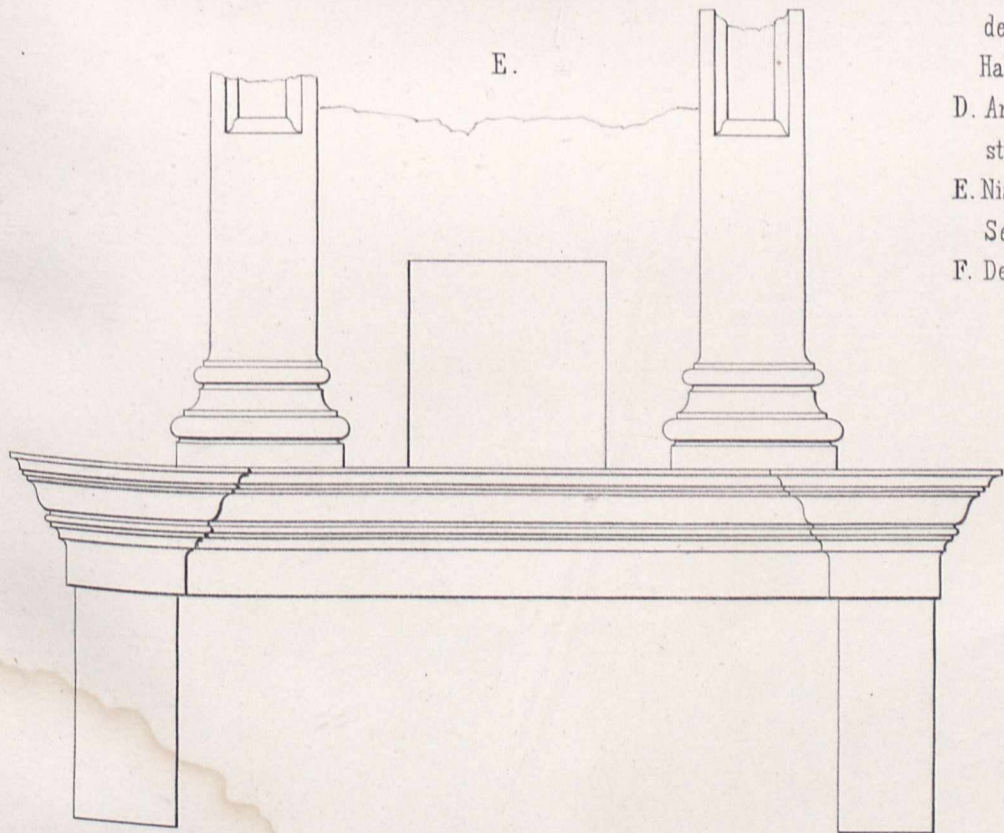
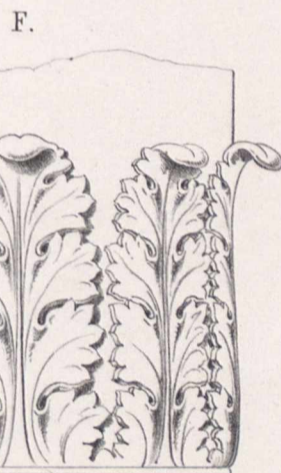
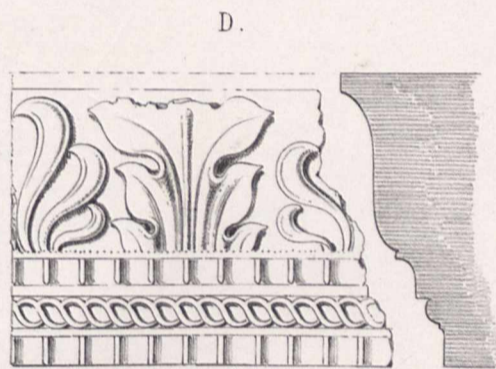
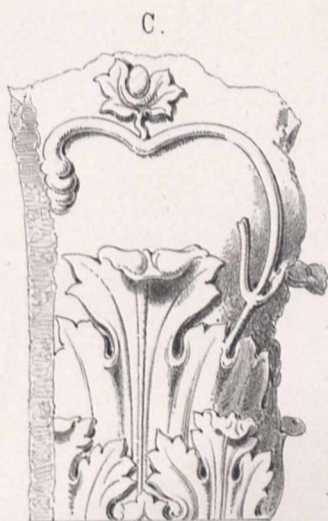
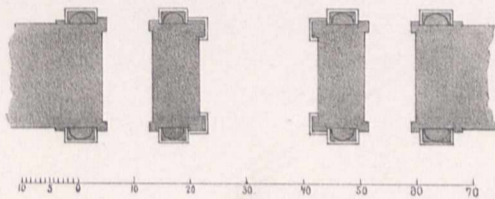
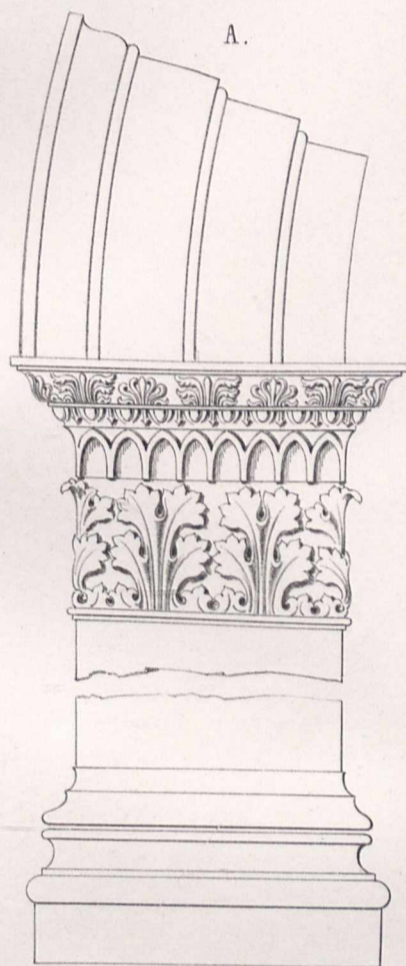

- A. Eckpfeiler und Bogen-  
Anfang des Haupt-  
Portales.
- B. Eckpfeiler und Bogen-  
Anfang eines Neben-  
Portales.
- C. Seitenansicht eines  
der Capitale der  
Halbsäulen.
- D. Ansicht eines Gesims-  
stückes.
- E. Nische über einem der  
Seiten-Portale.
- F. Detail einer Halbsäule.

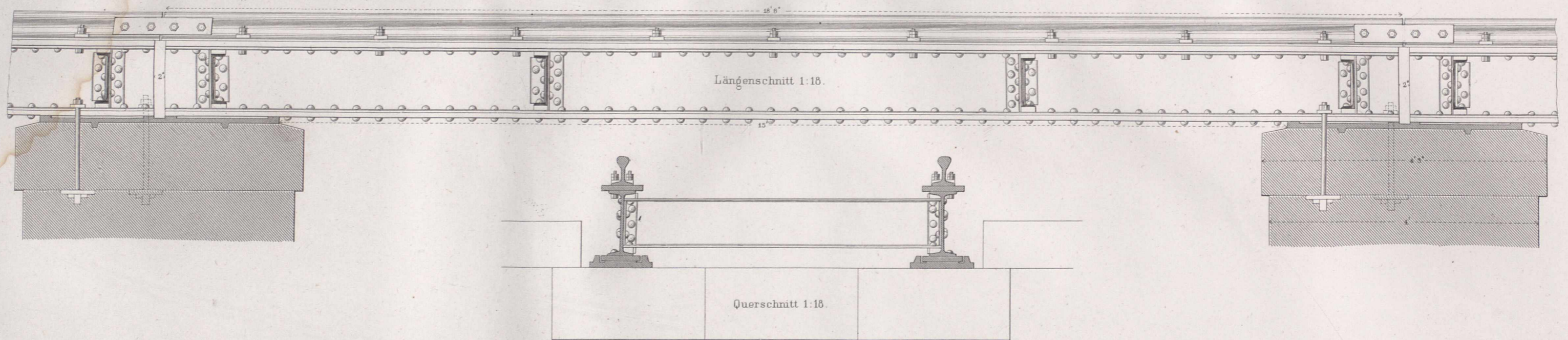

Längenschnitt der Ueberbrückung 1:4.

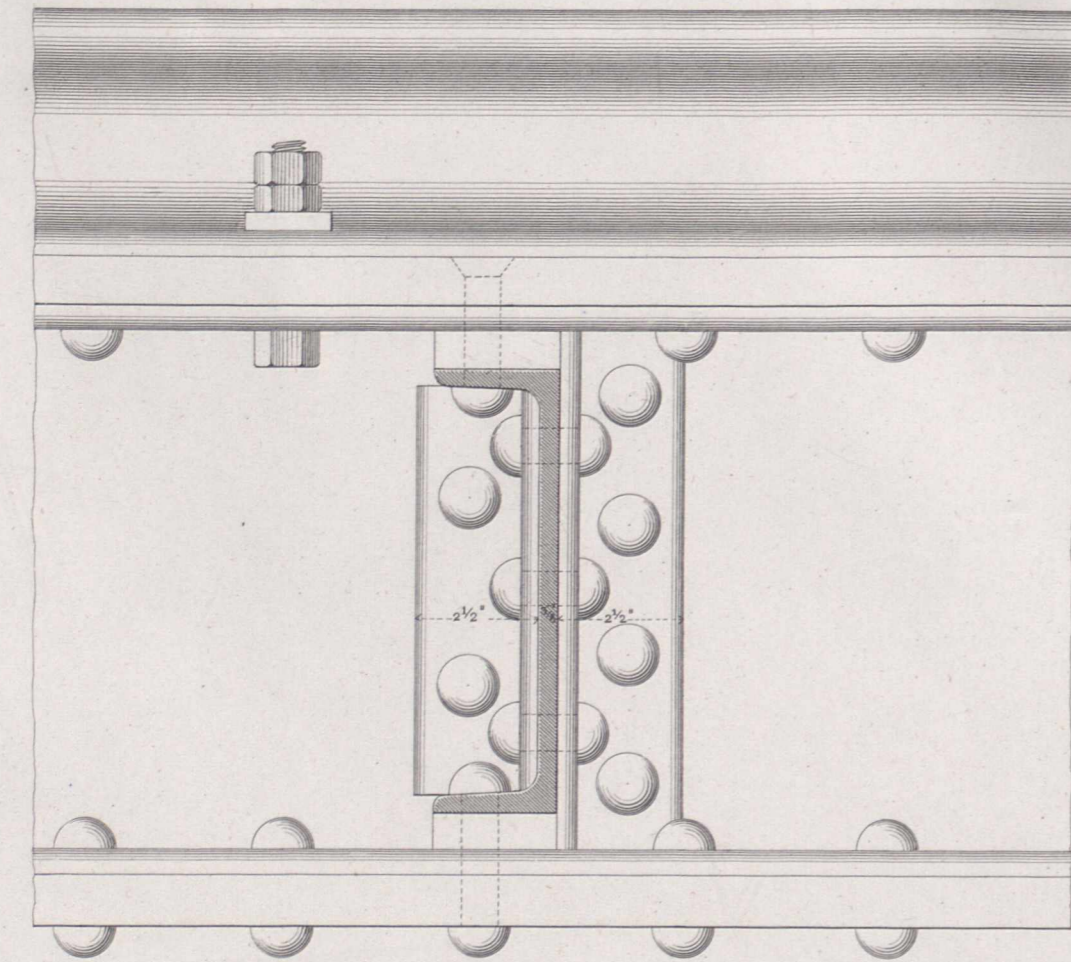

1:4

Gulfeiserne Lagerplatte 1:8.

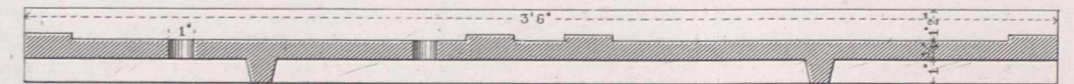

Längenschnitt.

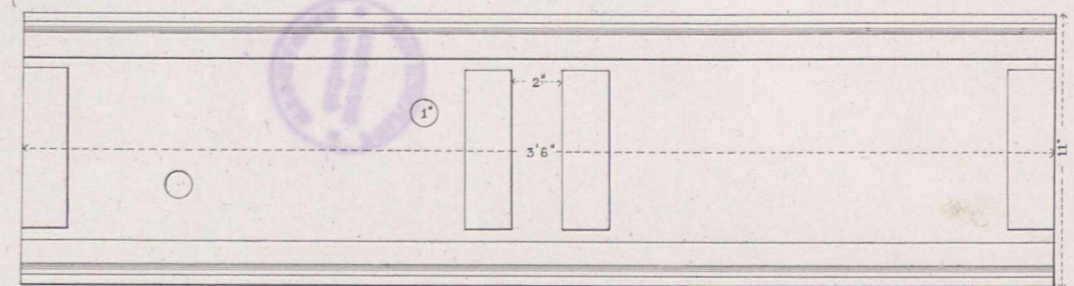

Ansicht von oben.

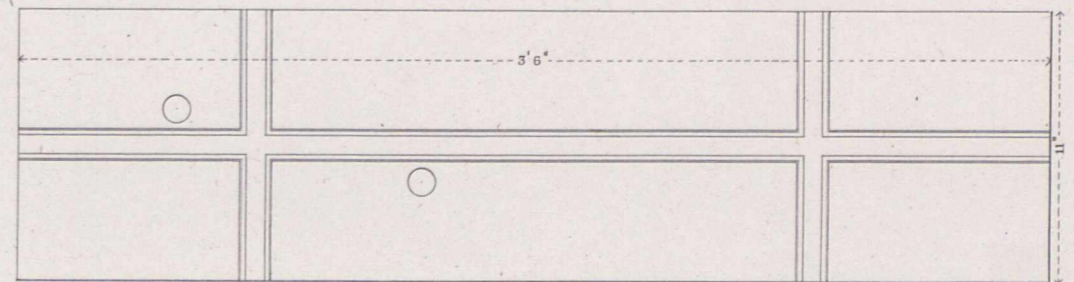

Ansicht von unten.

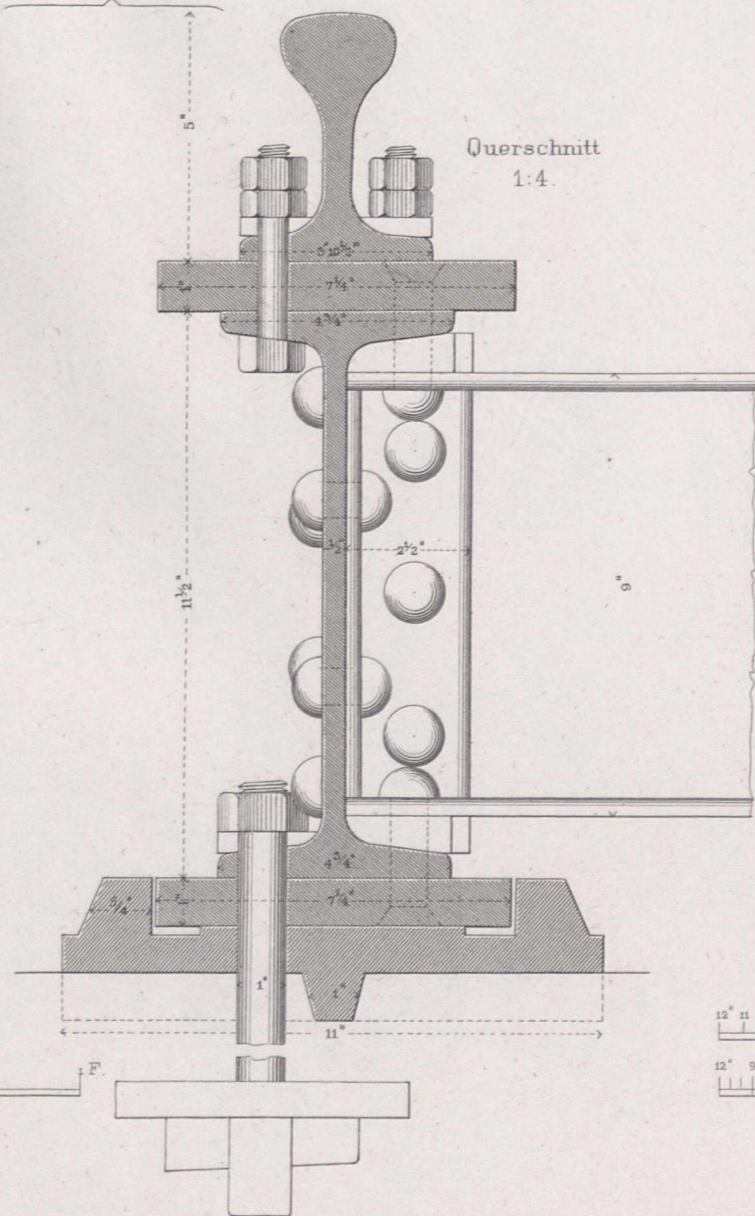

Querschnitt  
1:4.

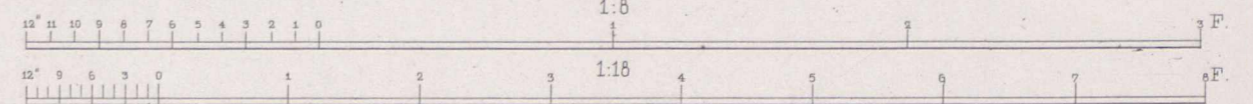



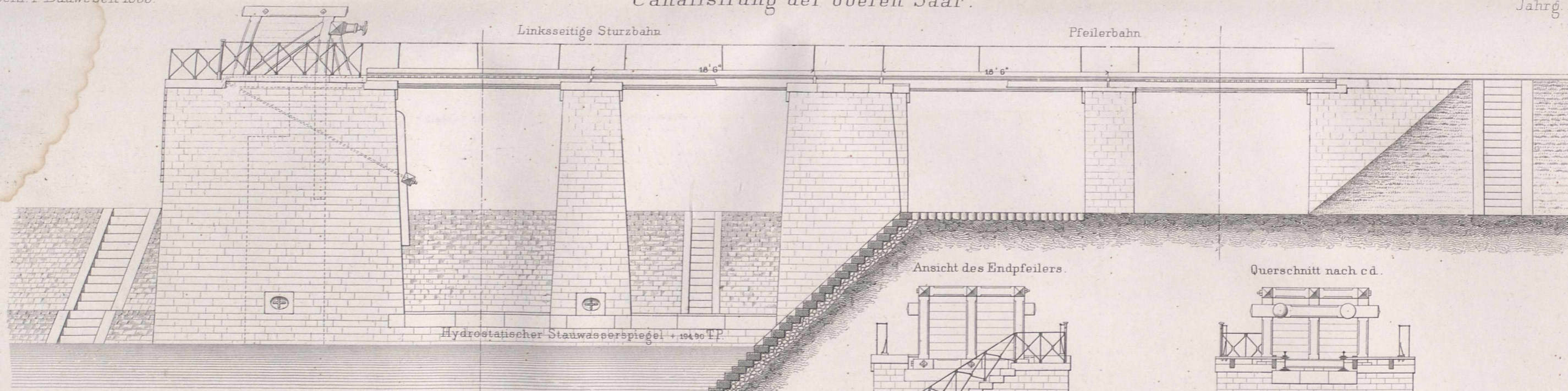

Hydrostatischer Stauwasserspiegel + 194,90 TP.

Ansicht des Endpfeilers.

Querschnitt nach c d.

Querschnitt nach ab.

Querschnitt nach ba.

+ 194,90 TP

194,90 TP

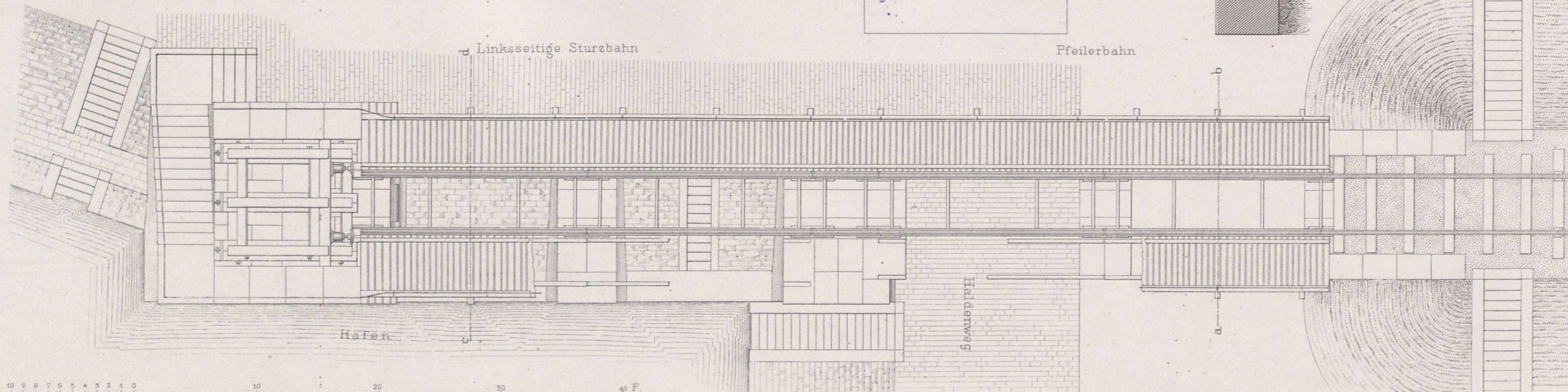

Linksseitige Sturzwehr

Pfeilerwehr

Hafen

Halderweg

0 10 20 30 40 F.

Querschnitt nach c d.

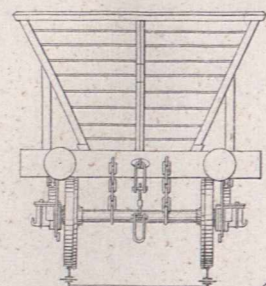

Längensicht.

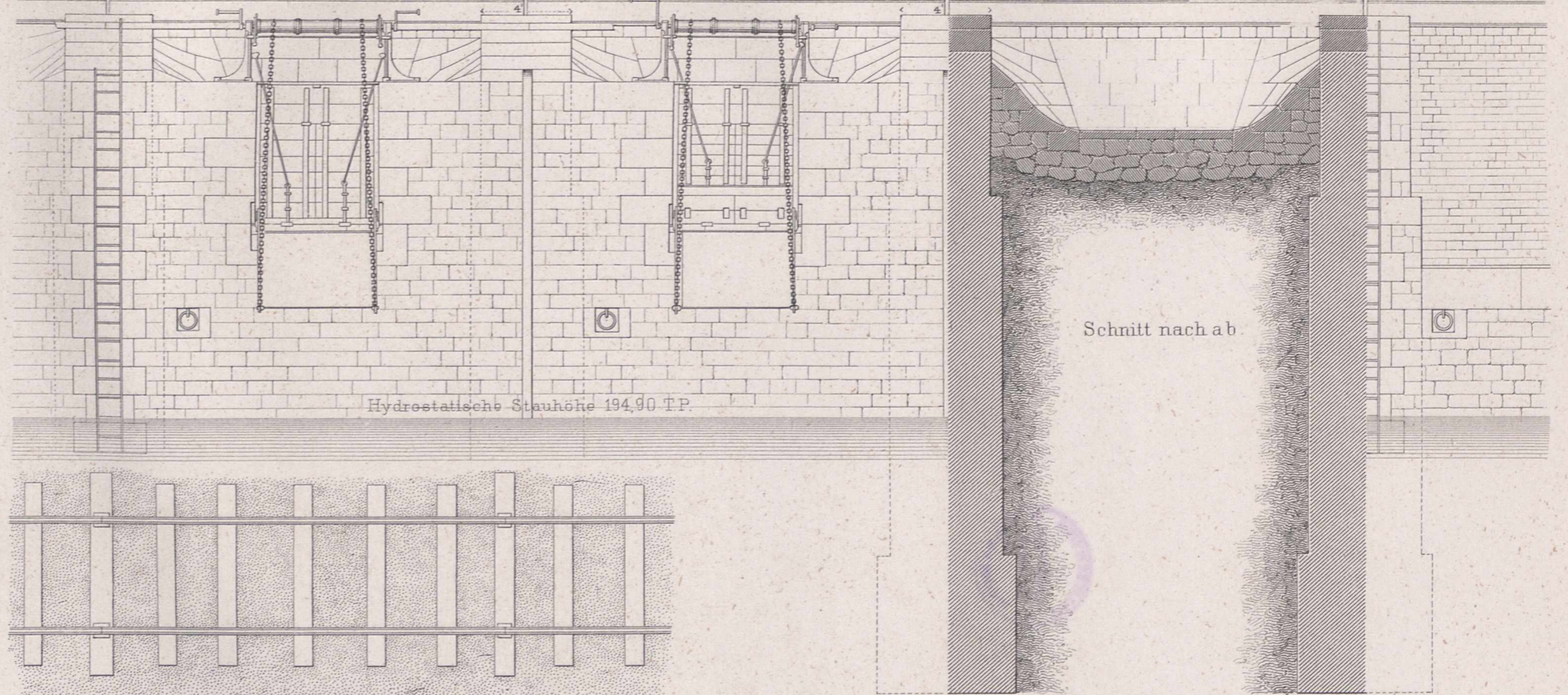
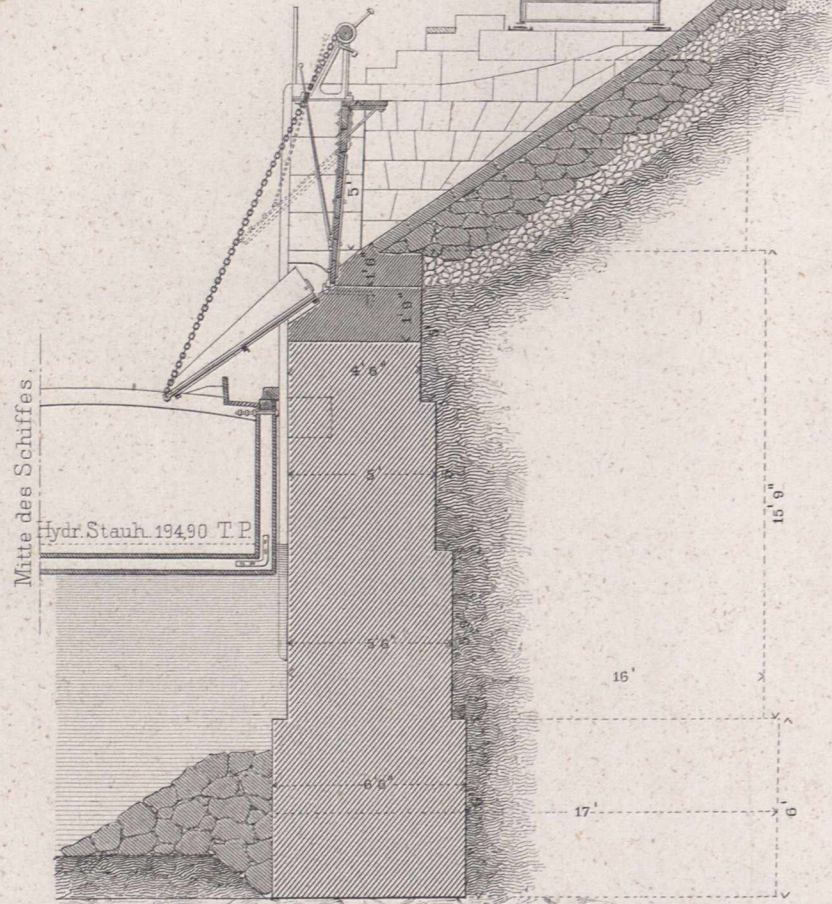
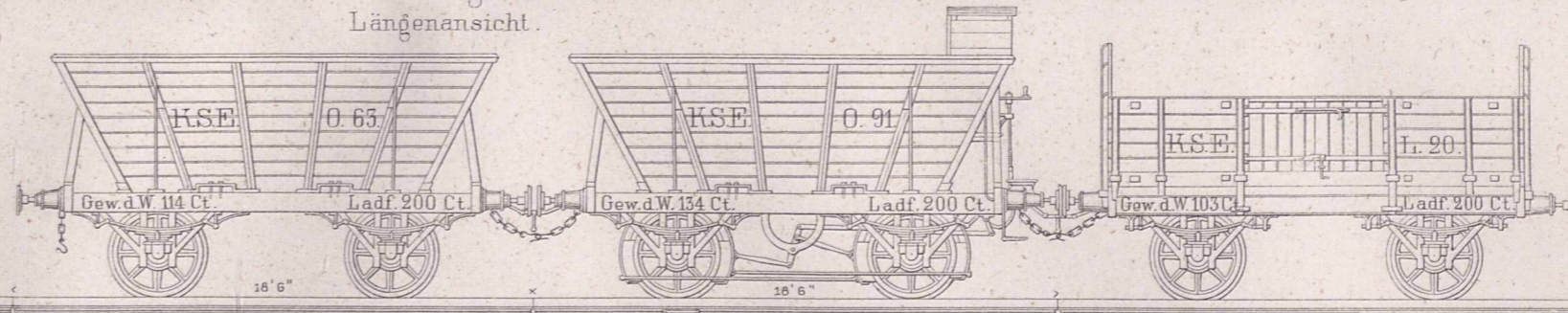

Hintere Ansicht der Rinne. Durchschnitt und hintere Ansicht der Klappe und der Schüttöffnung.

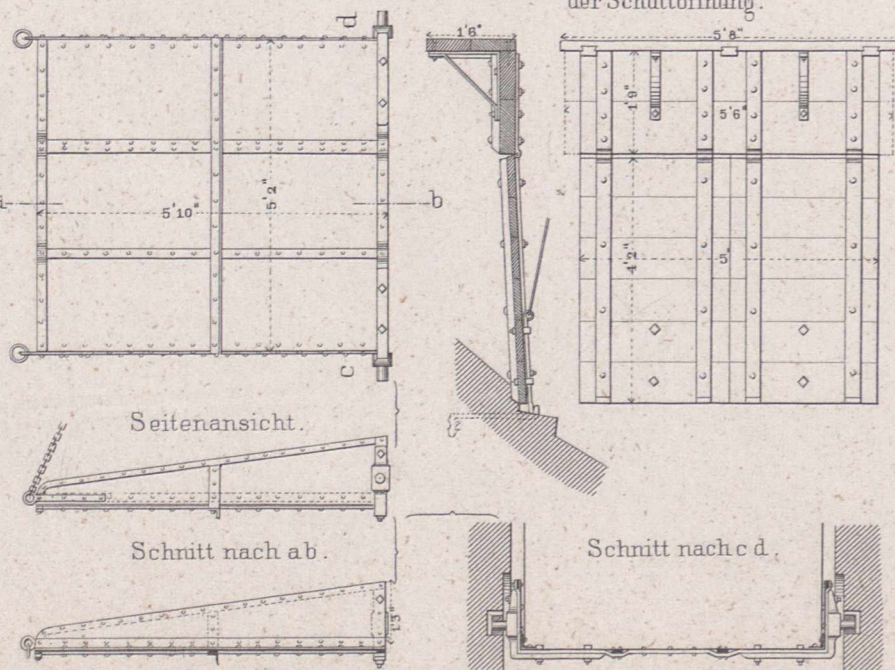

Oberansicht

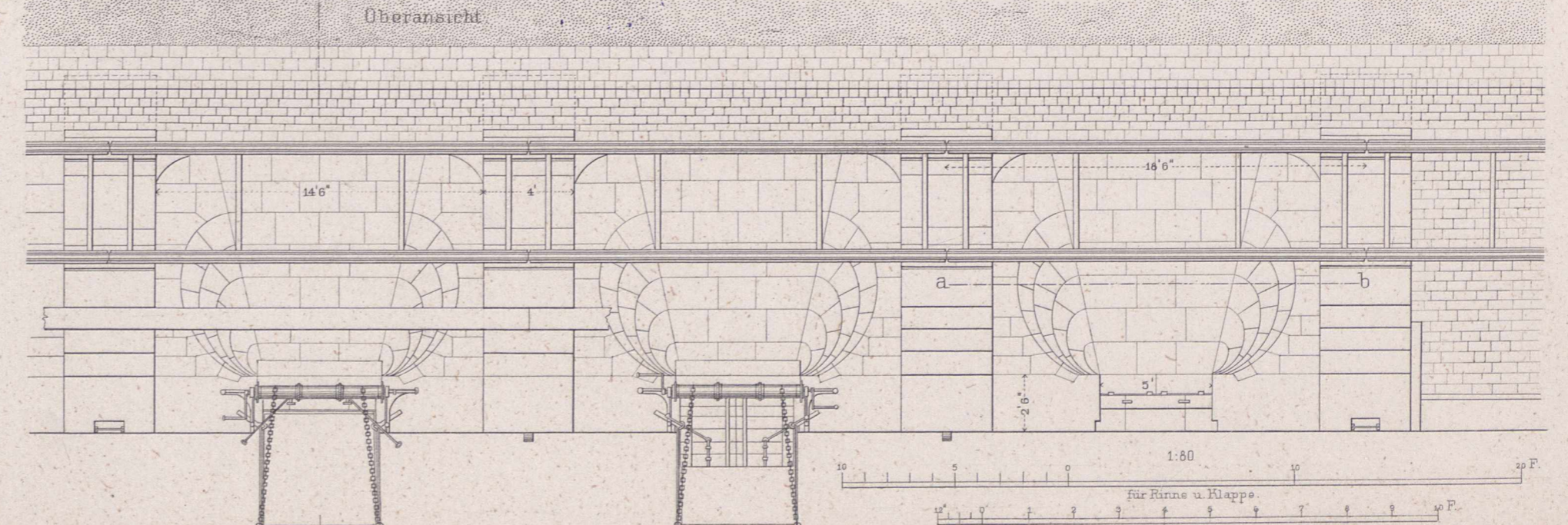

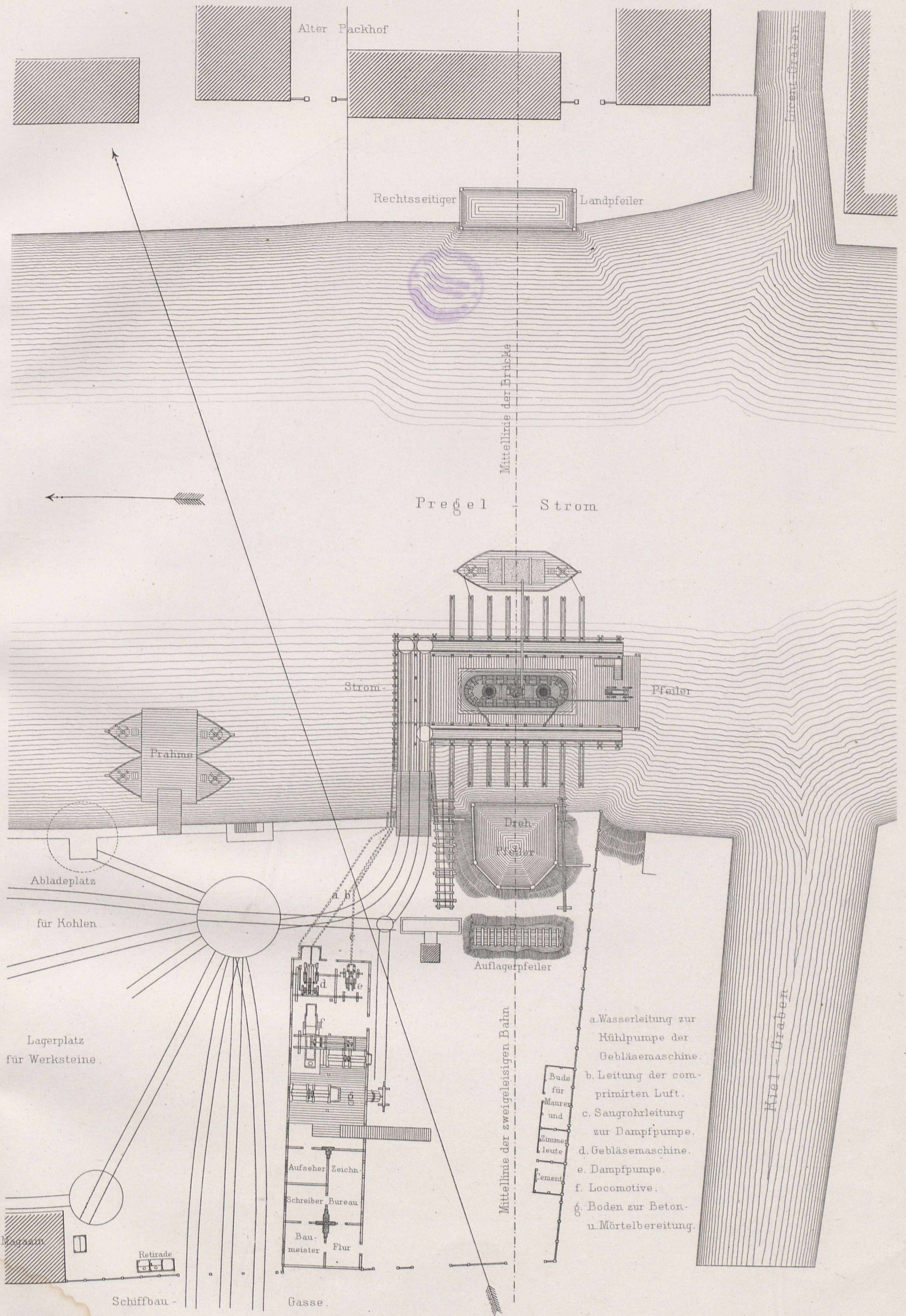

100 50 0 100 200 F.

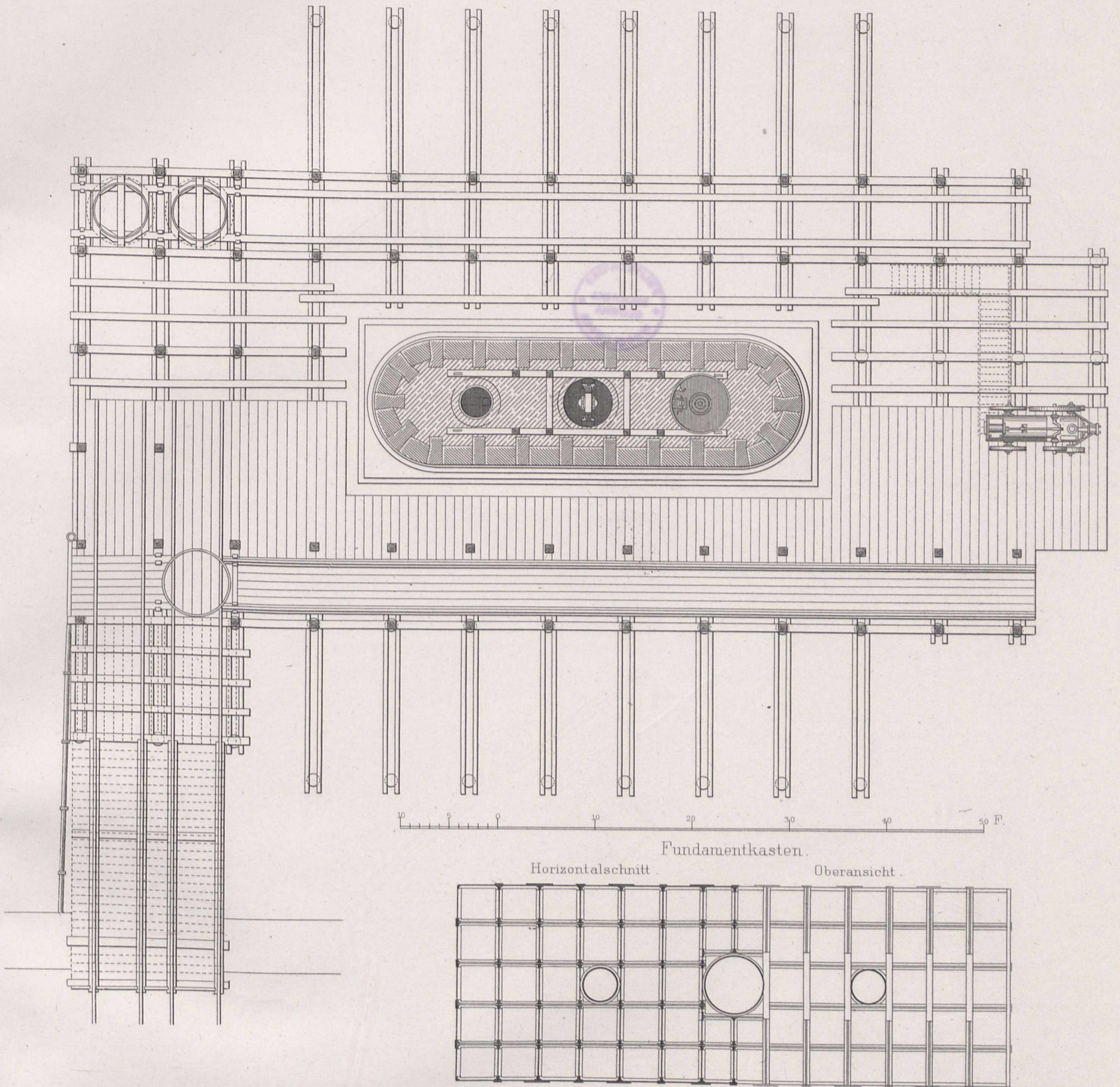

Oberer Grundriß des Strompfeiler-Gerüsts.

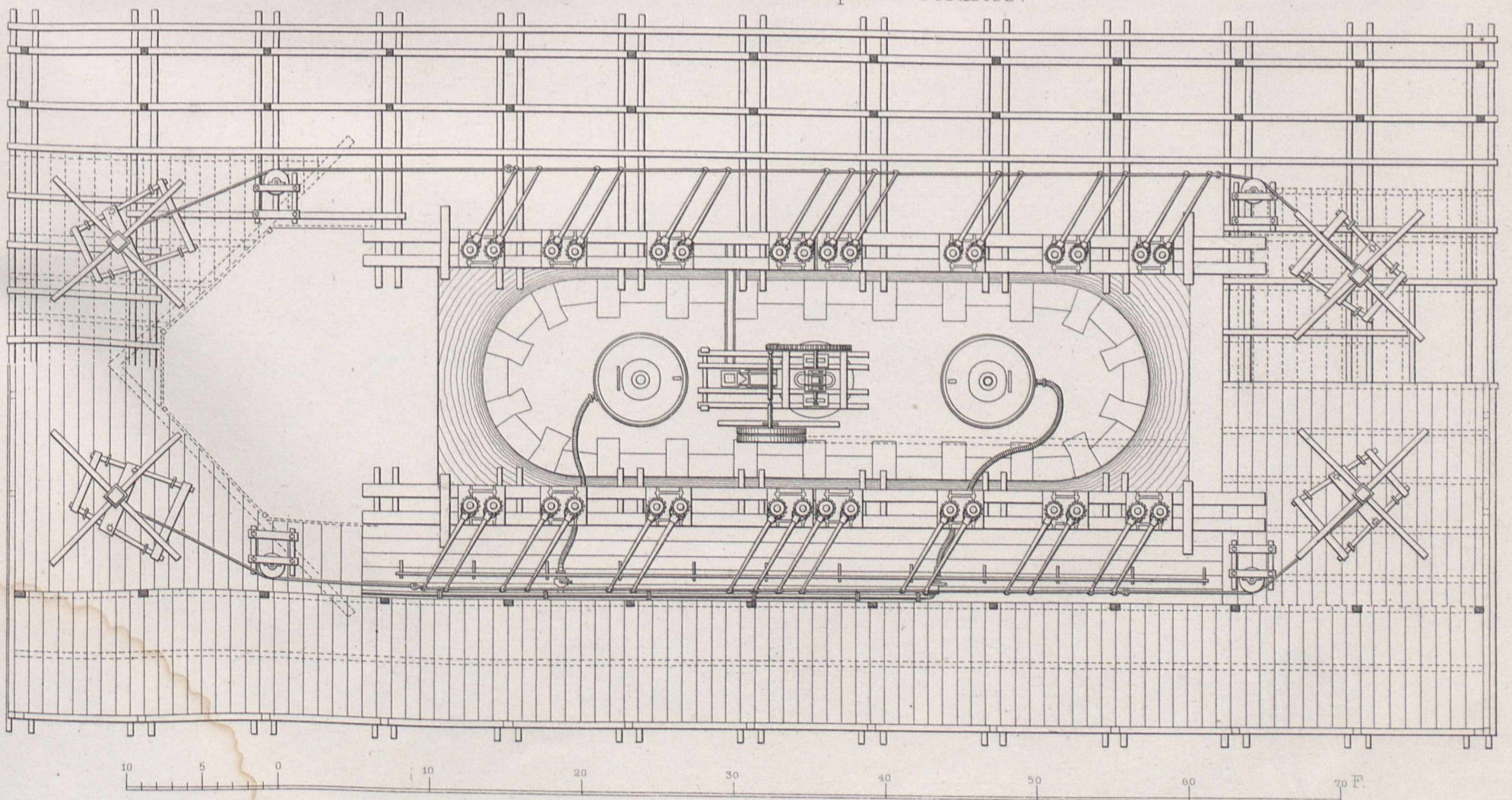

Pregel-Brücke  
Querschnitt des Strompfeilers

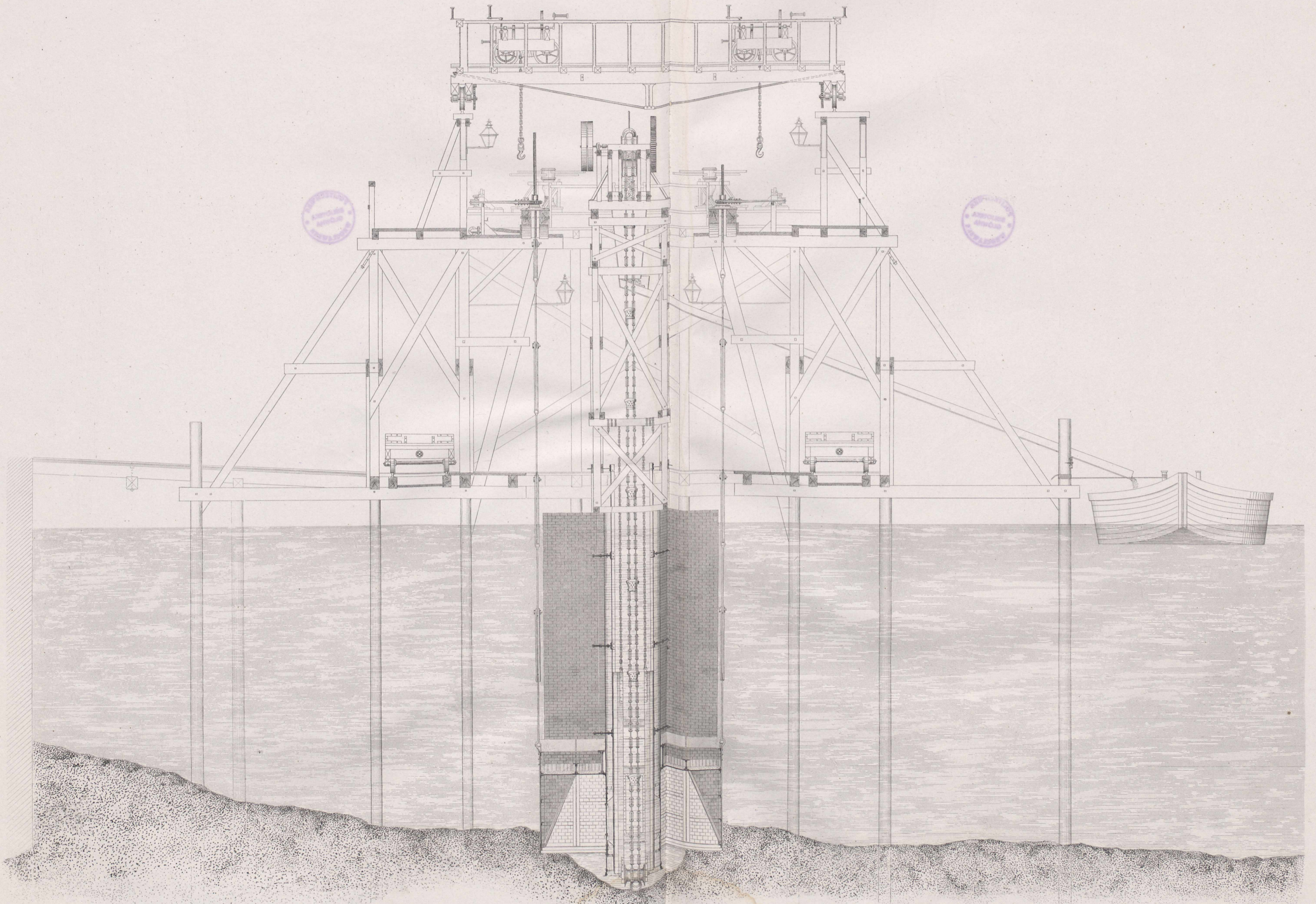

10 9 8 7 6 5 4 3 2 1 0 10 20 30 40 50 60 Fuss

Ernst & Sohn Berlin.

Ritter gest.

Pregel-Brücke  
Längenschnitt des Strompfeilers

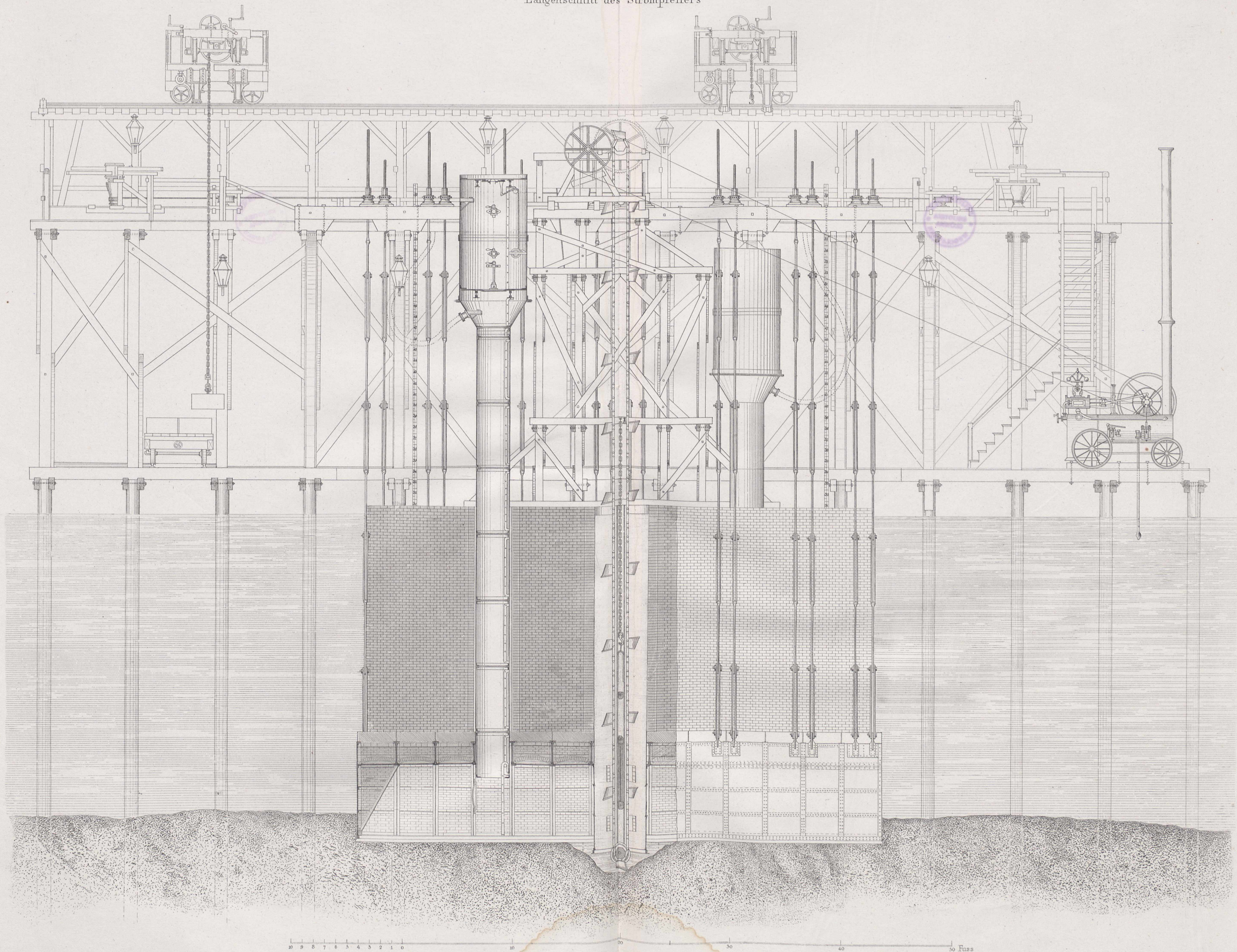

Ernst & Korn. Berlin.

Ritter gest.

Längenschnitt nach A B.

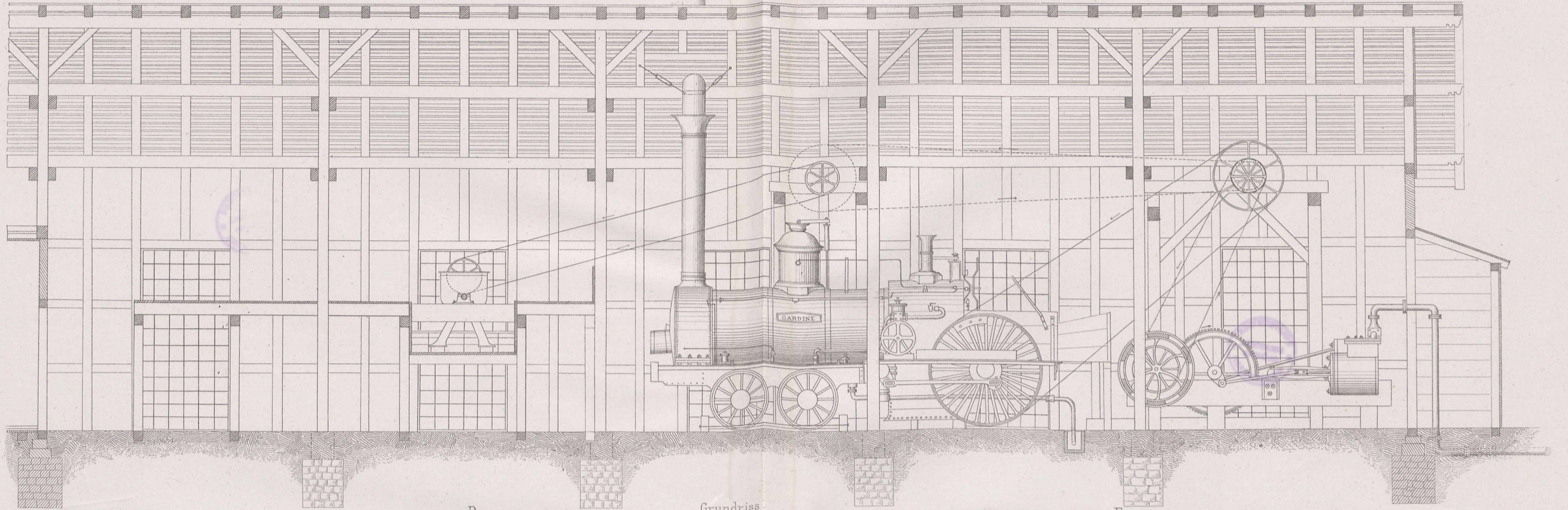

Grundriss

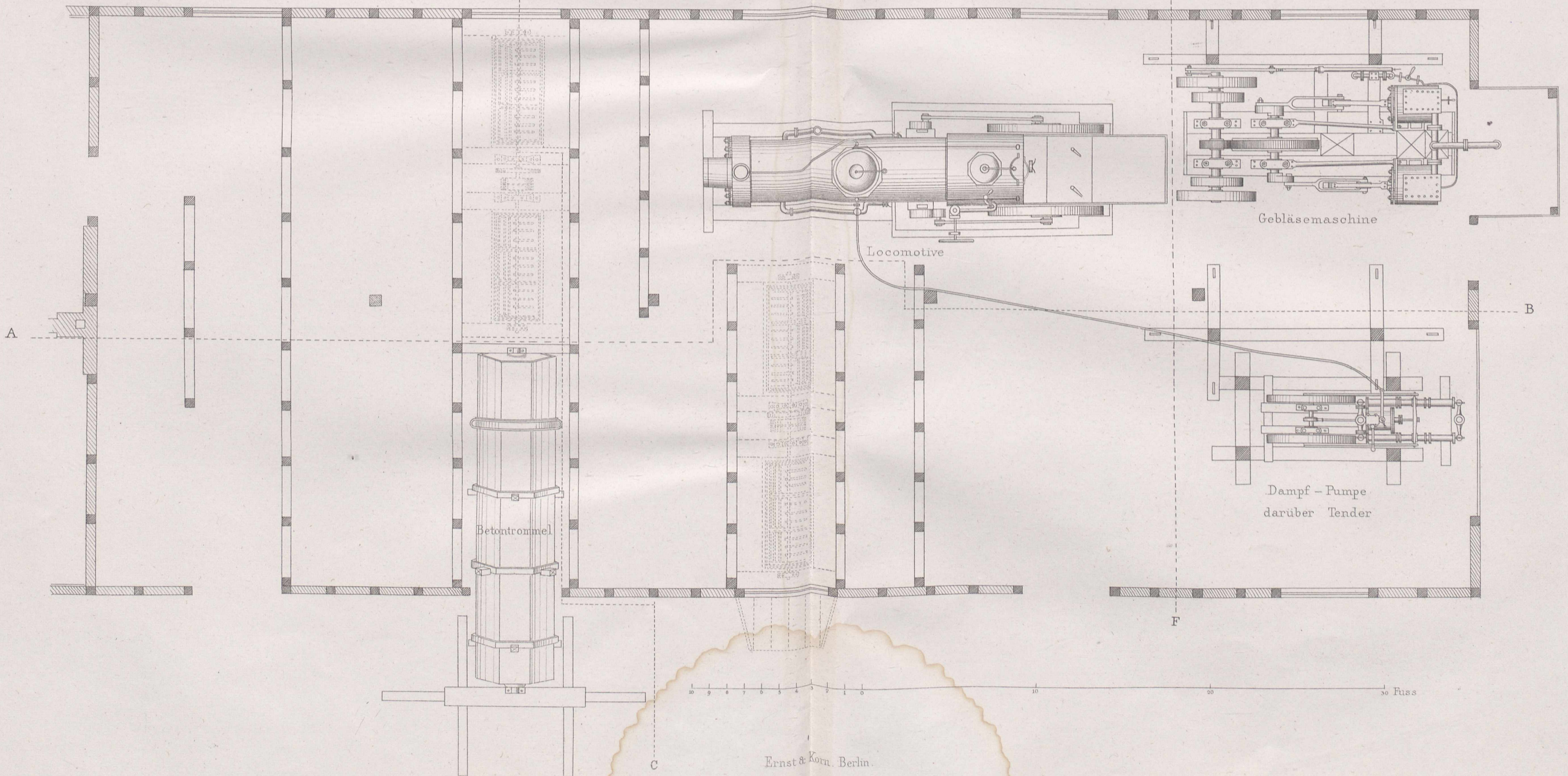

Bau- und Maschinen-Schuppen.

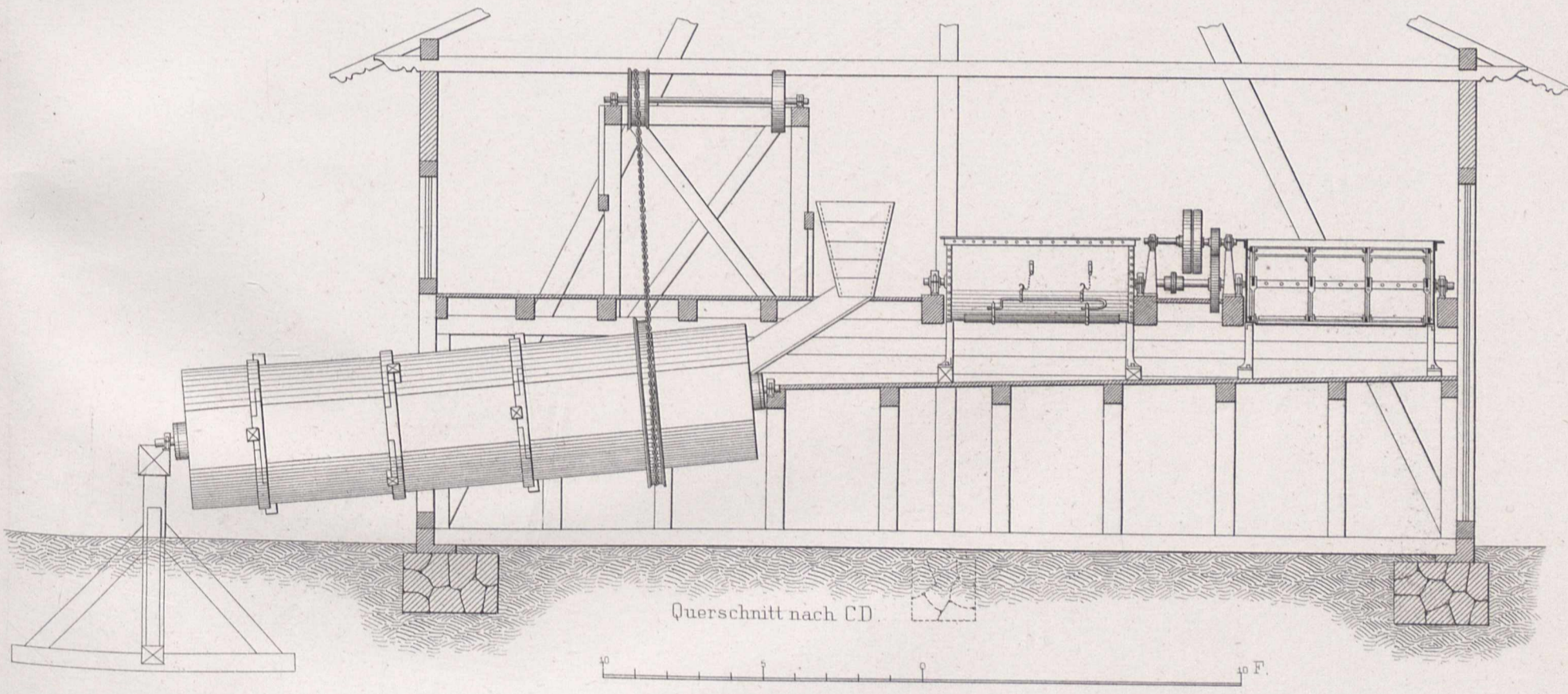
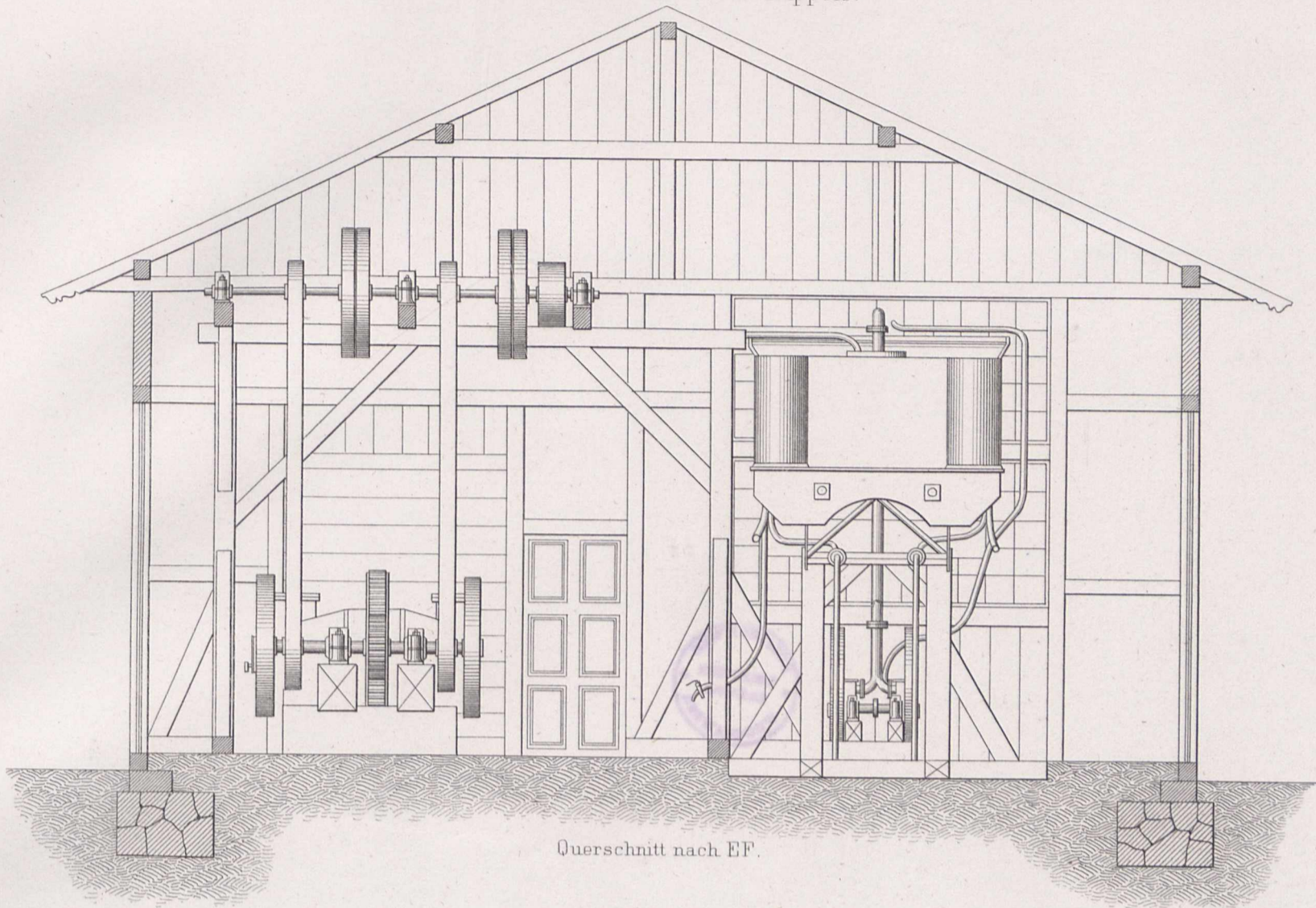

Drehscheibe auf dem Strompfeiler-Gerüst.

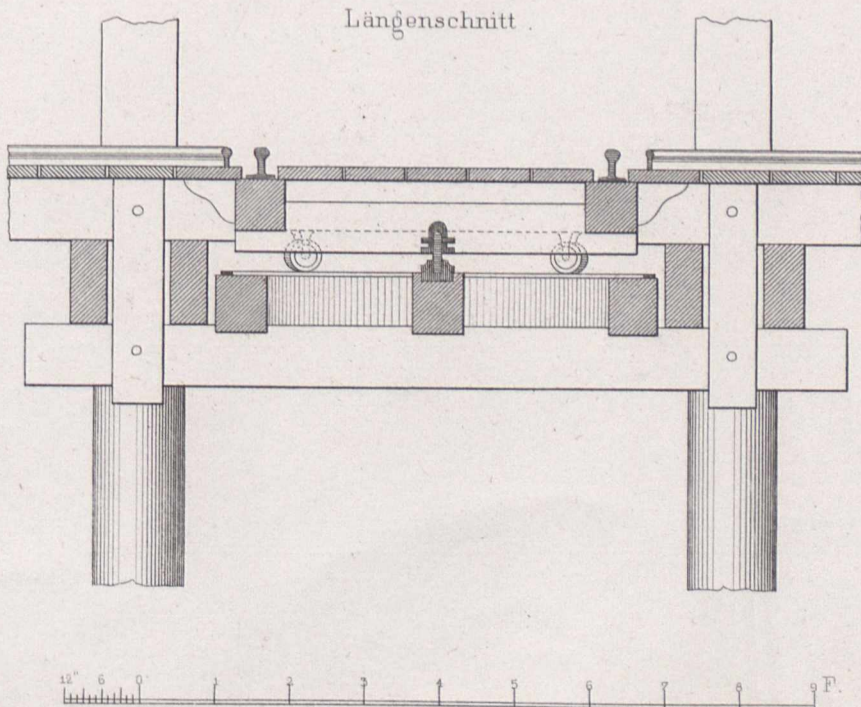
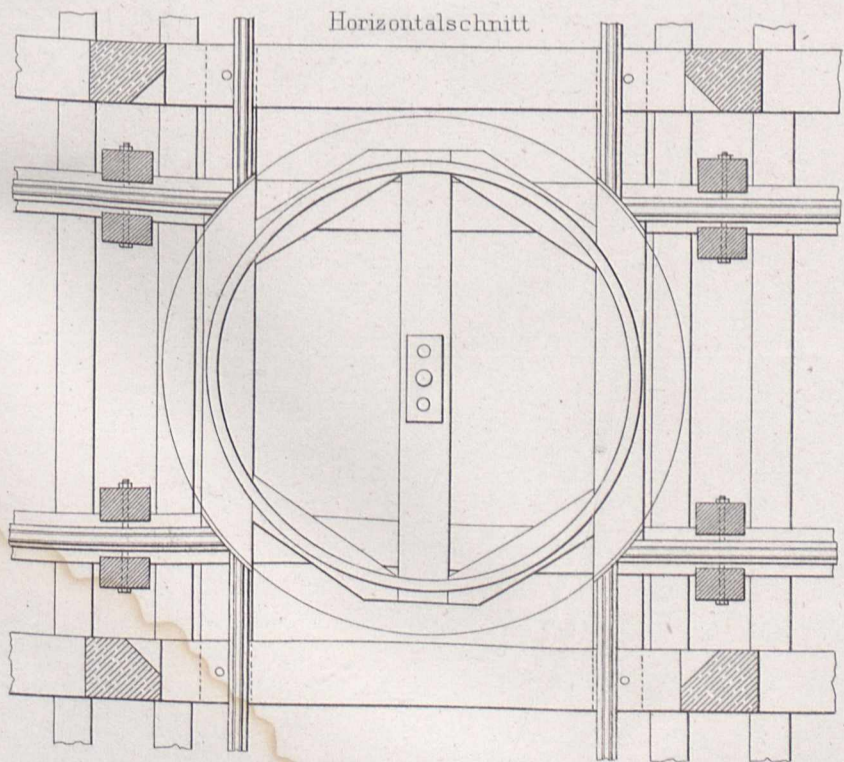



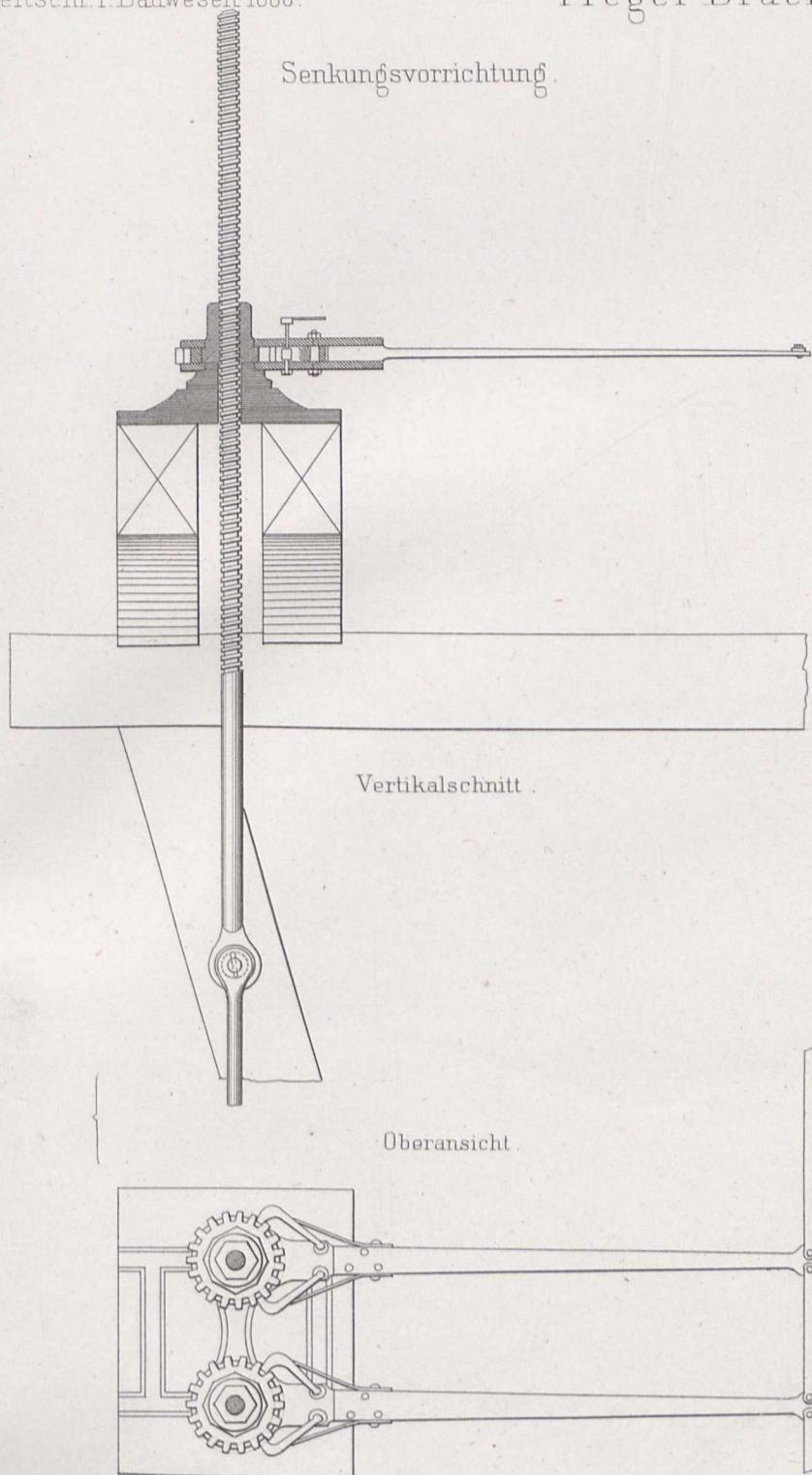

Senkungsvorrichtung.

Vertikalschnitt.

Oberansicht.

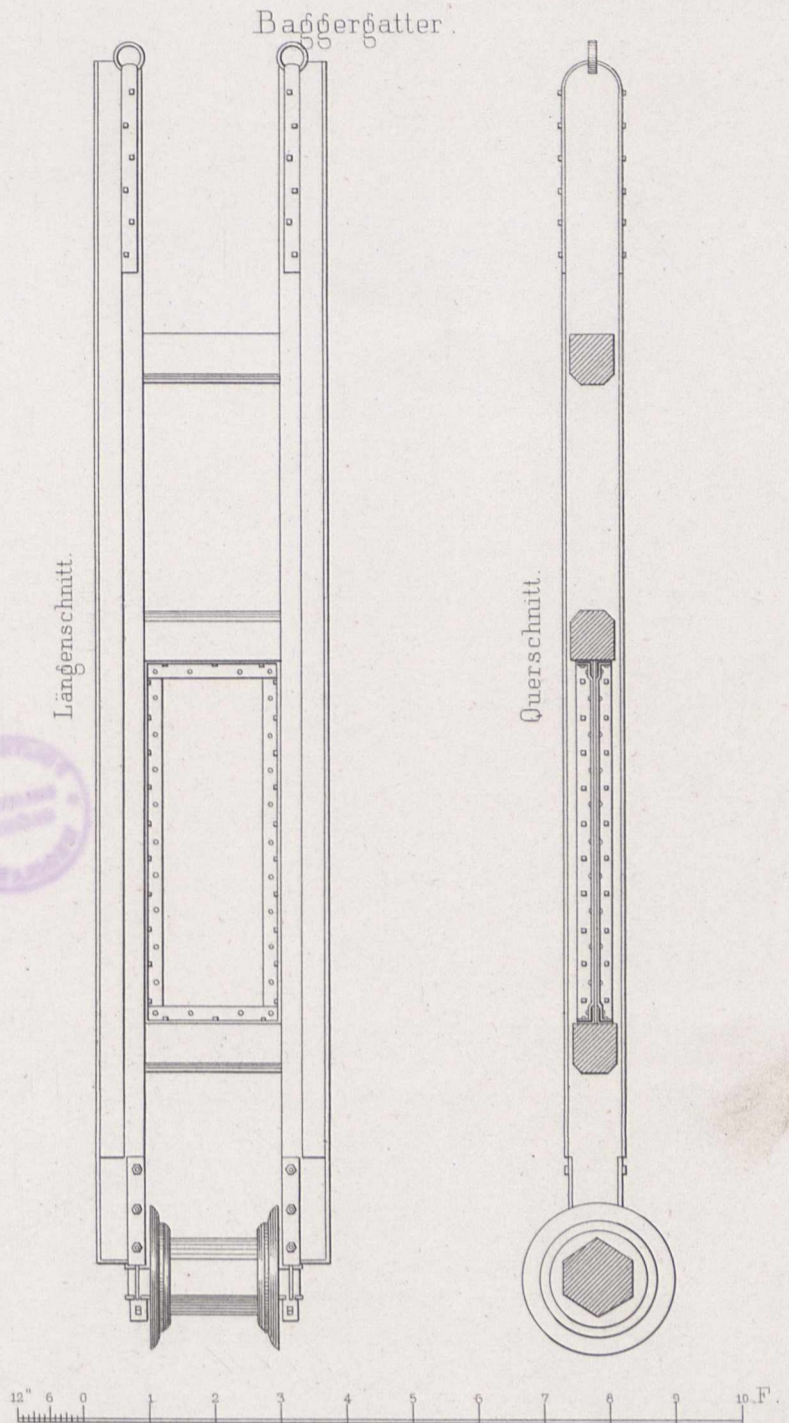

Baggergatter.

Längenschnitt.

Querschnitt.

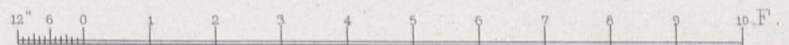

Pneumatischer Apparat.

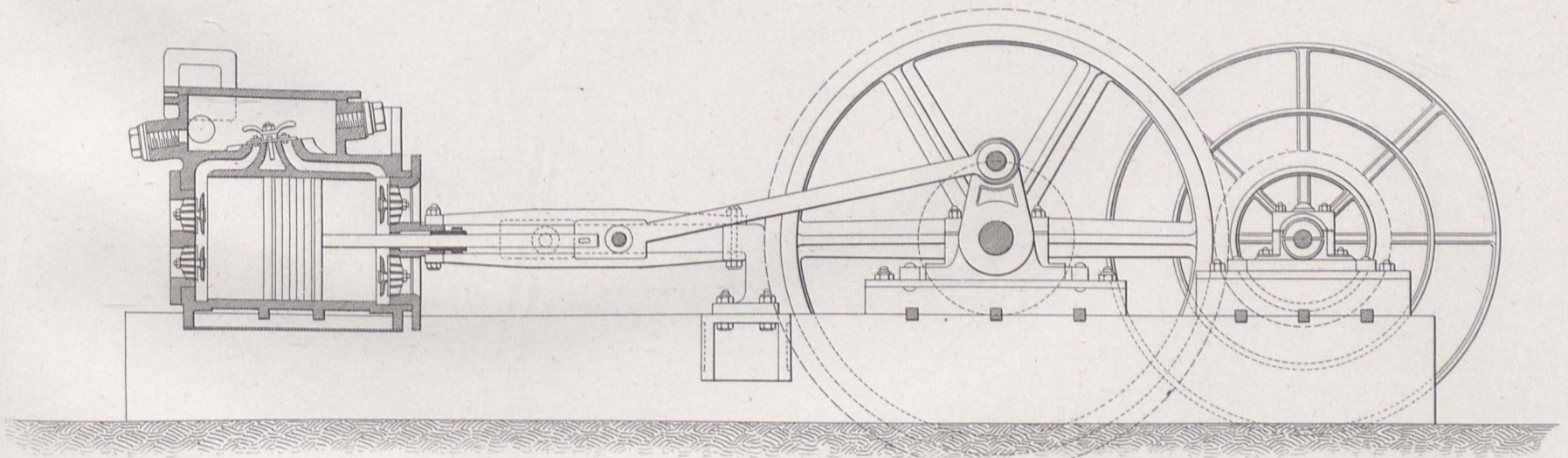

Längenschnitt und Ansicht.

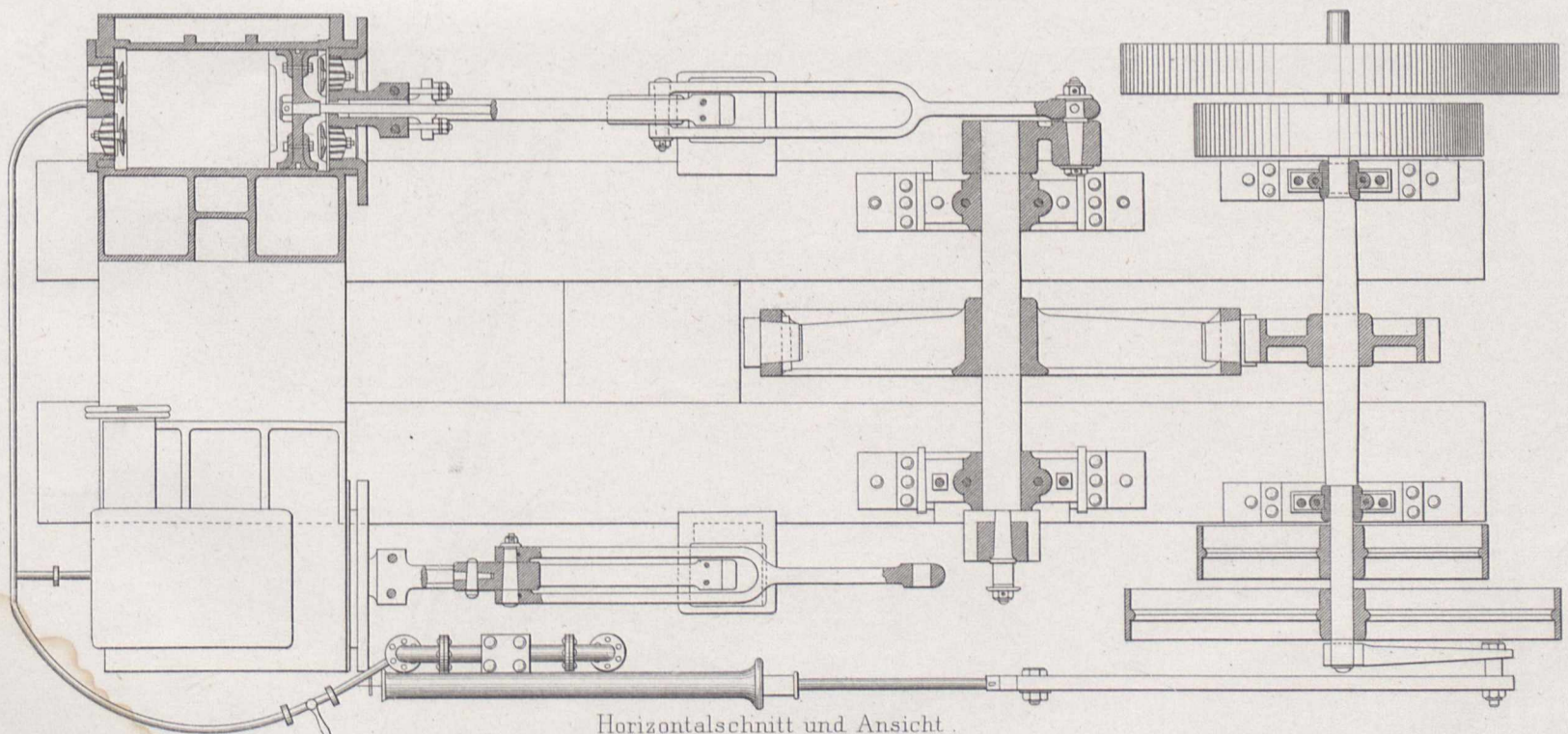

Horizontalschnitt und Ansicht.



Ansicht des Baugerüsts.

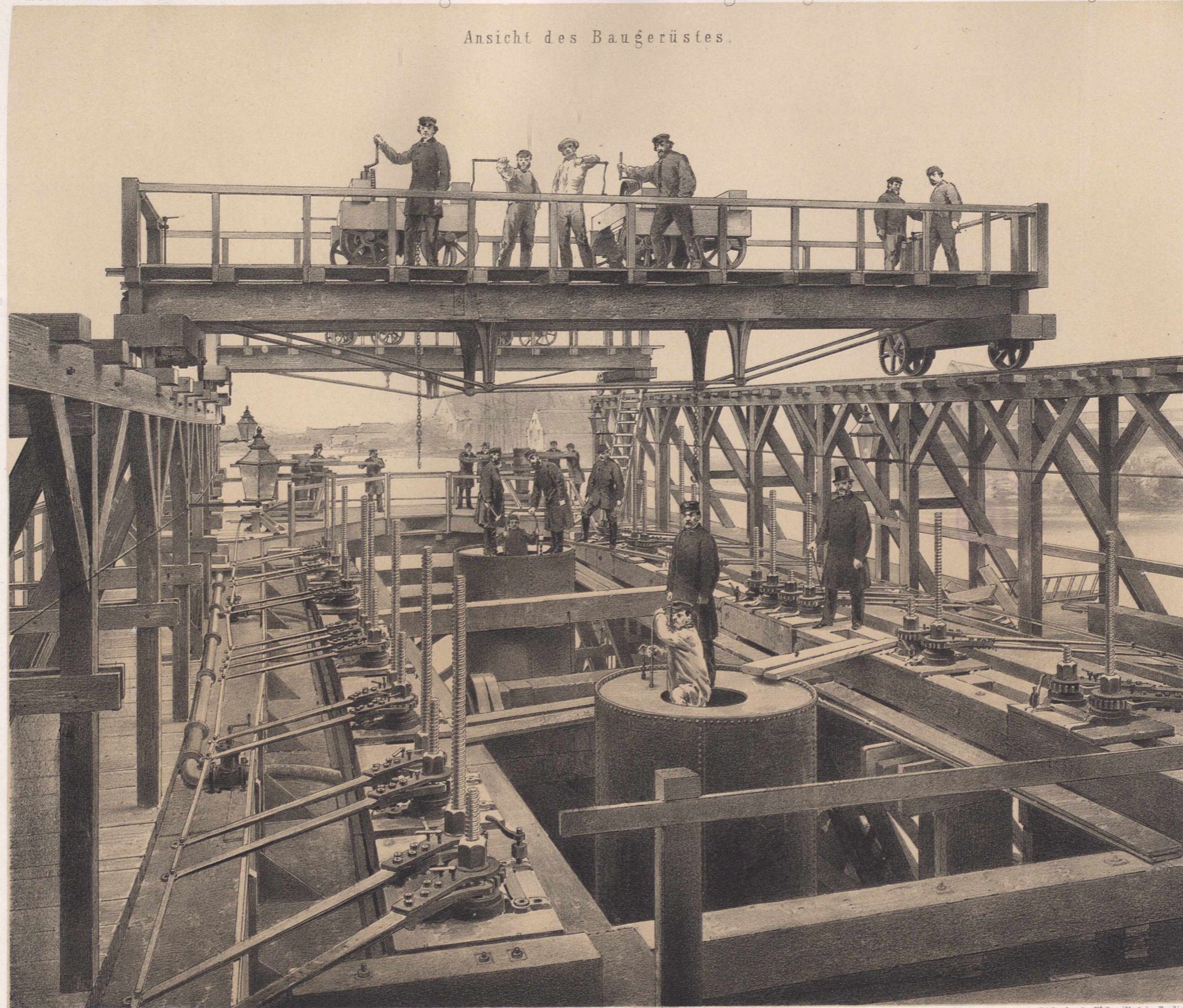

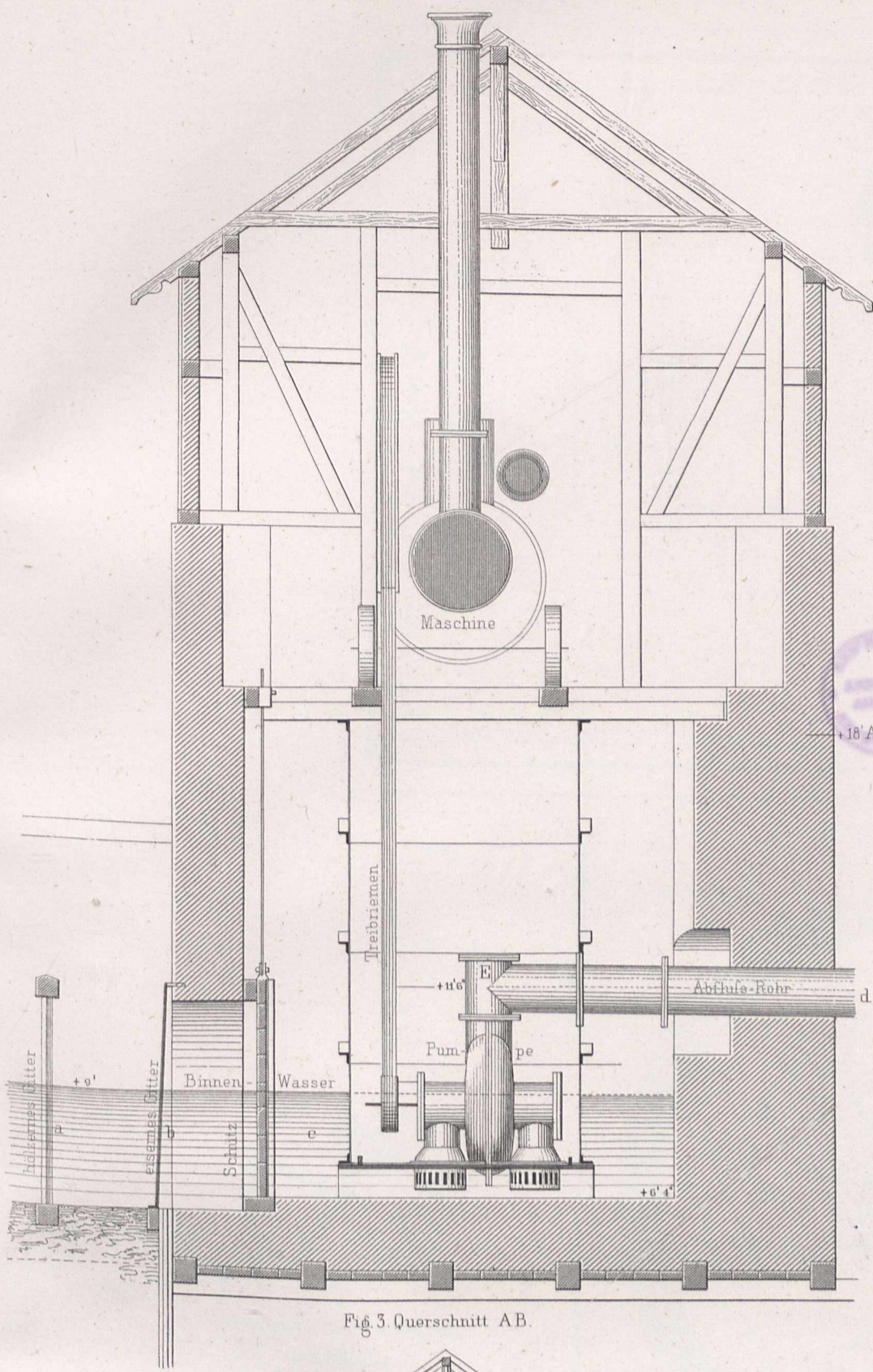

Fig. 3. Querschnitt AB.

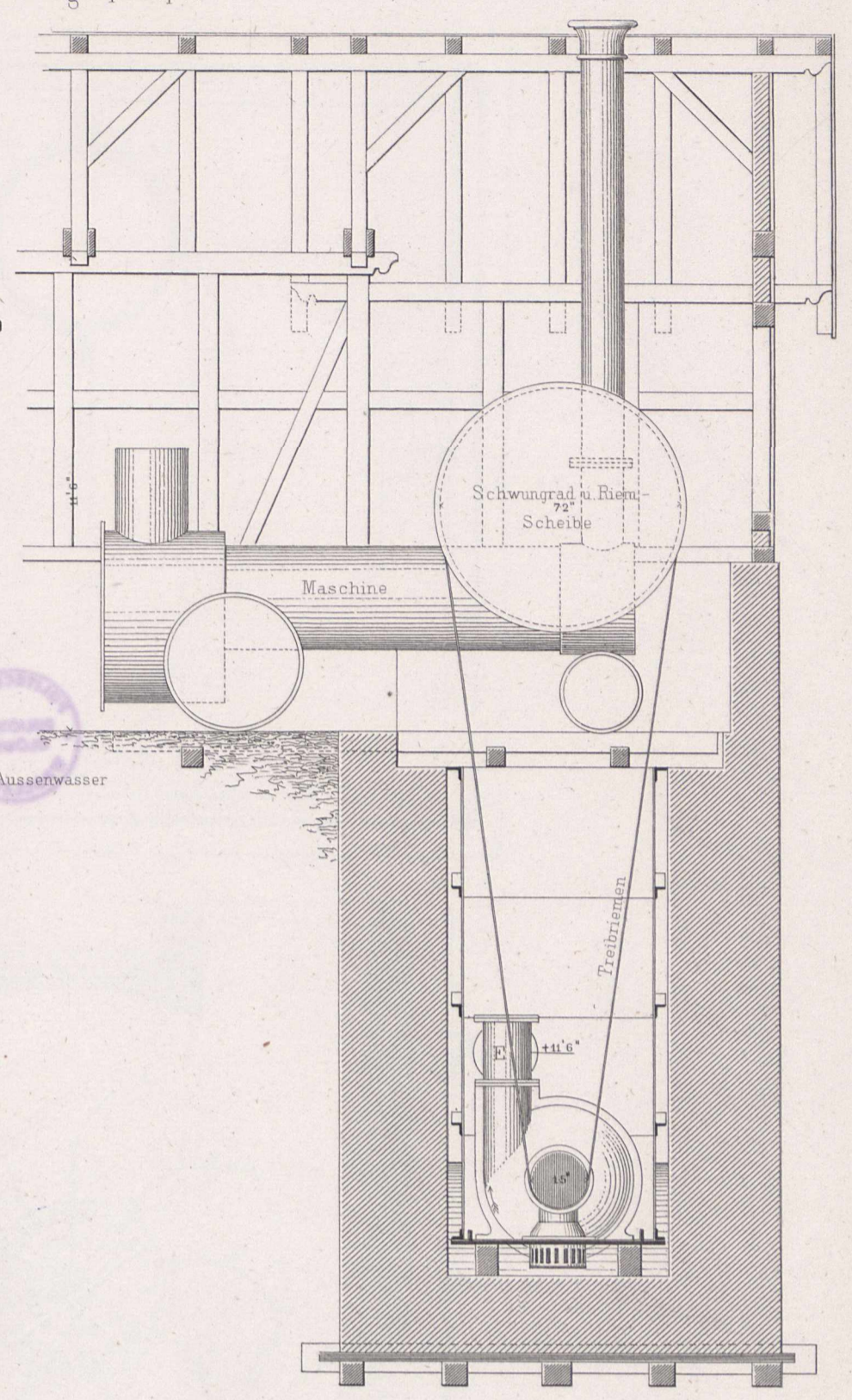

Fig. 4. Theil des Längenschnitts CD.

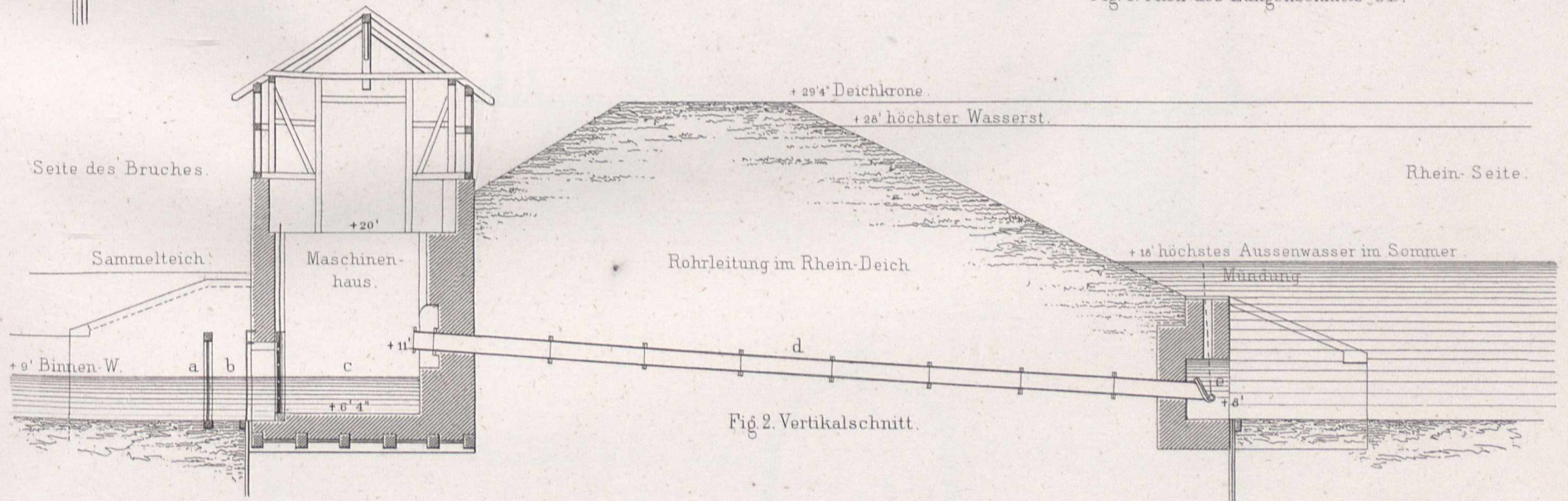

Fig. 2. Vertikalschnitt.

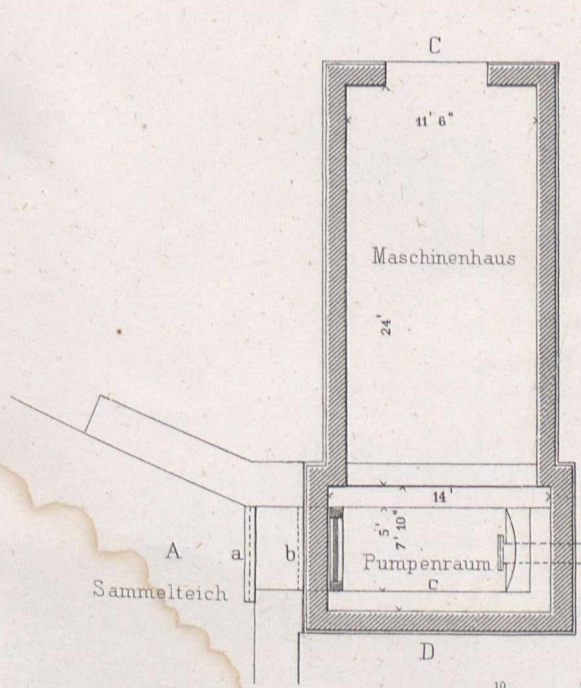

Fig. 1. Grundrifs.

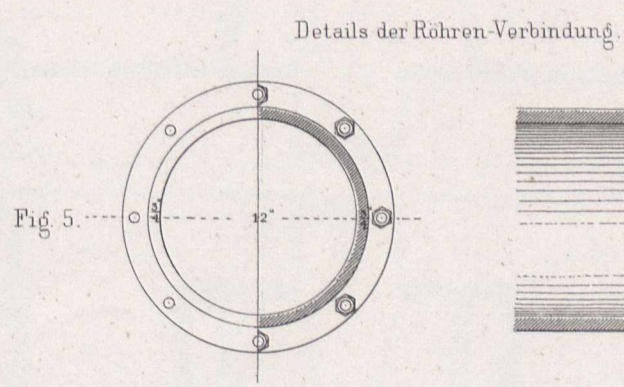

Fig. 5.

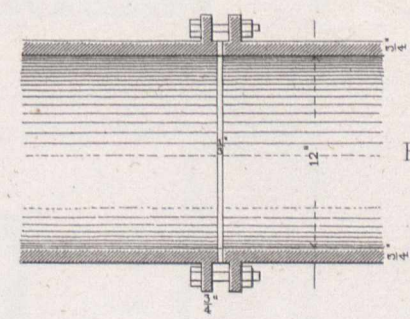
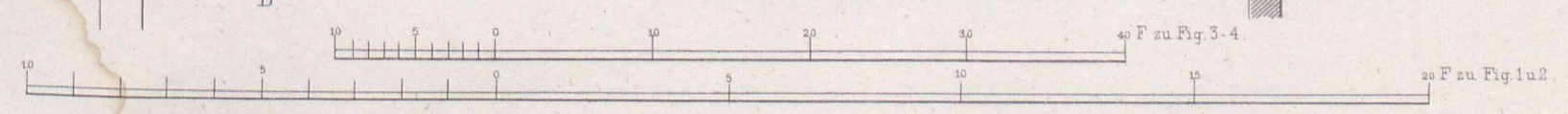
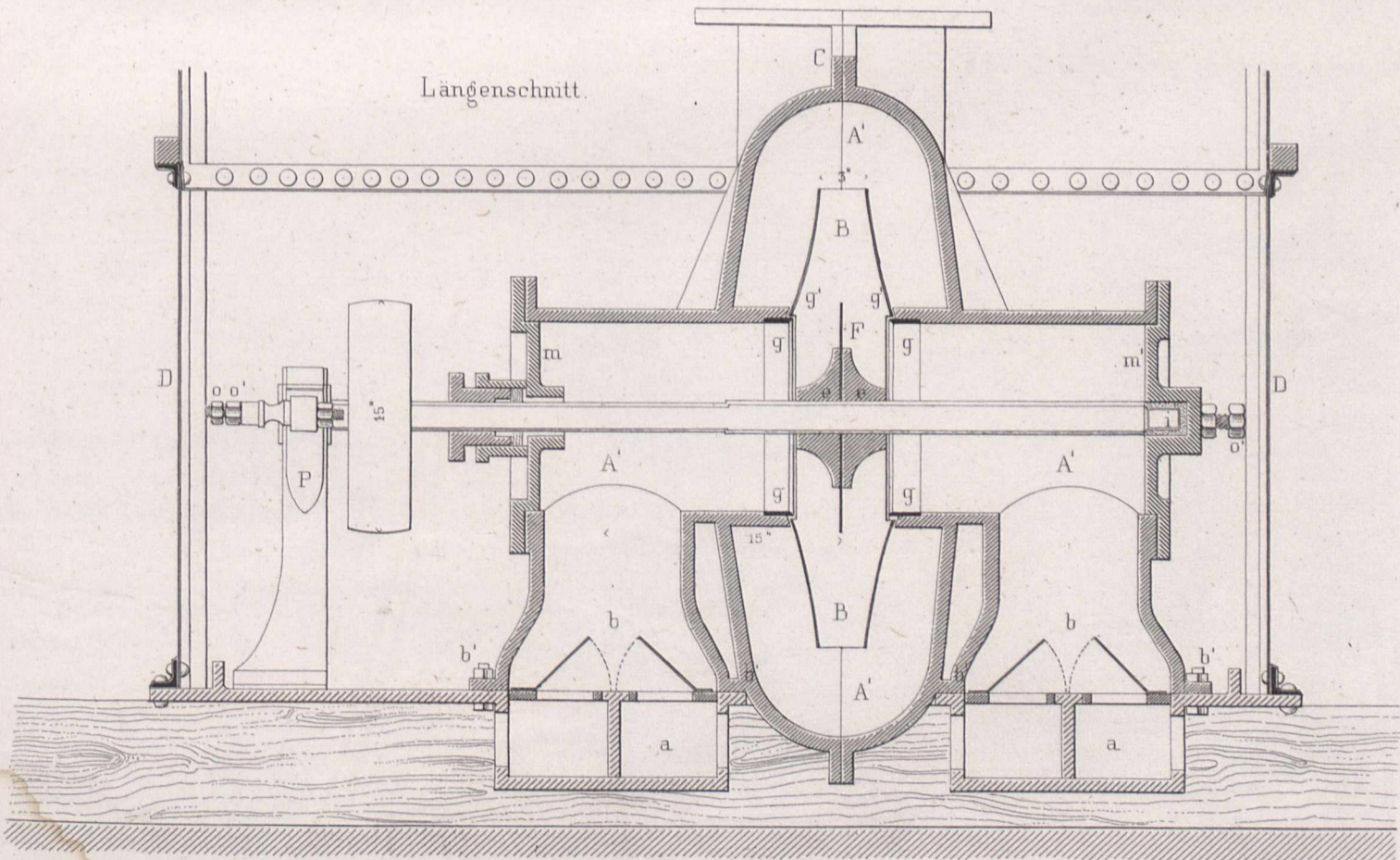
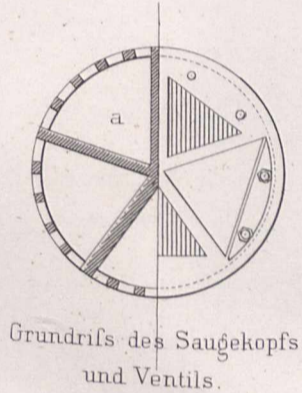
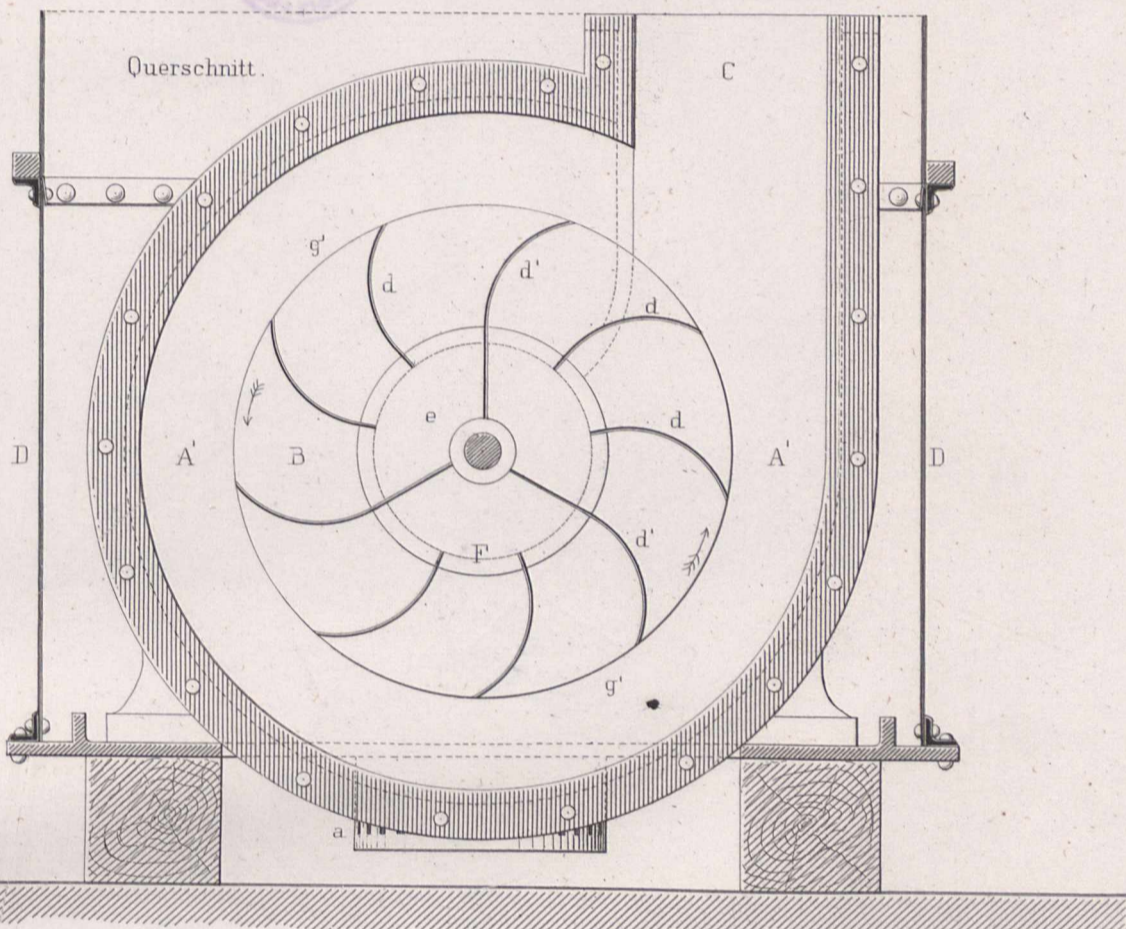
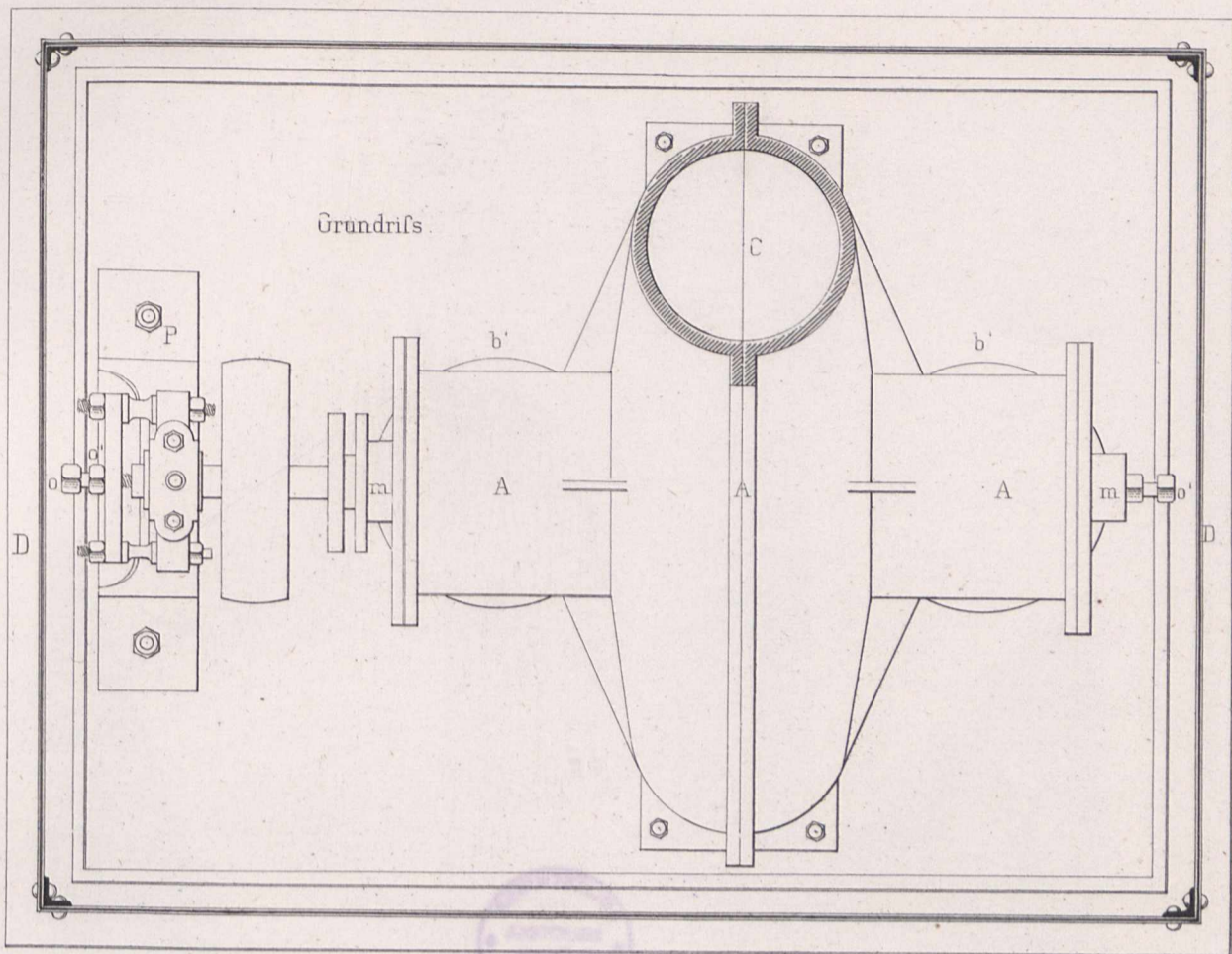
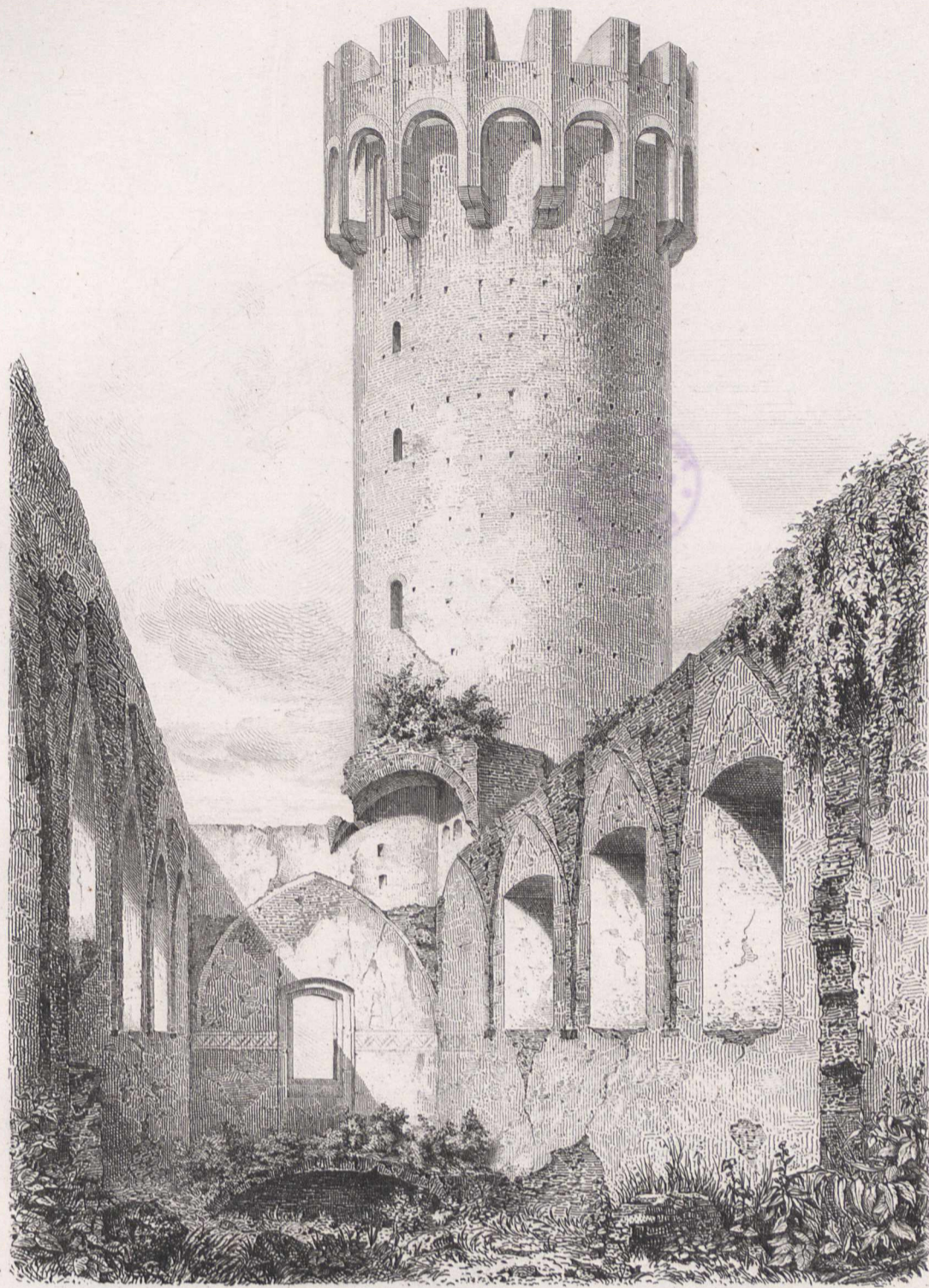

Fig. 6.







Grundriß der Haupt-Etage.

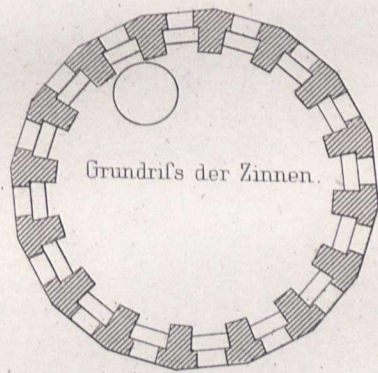
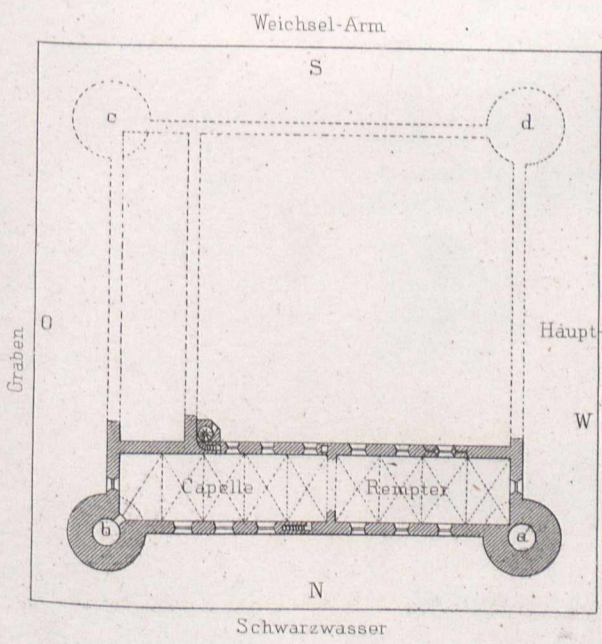

Durchschnitt des Thurmes.

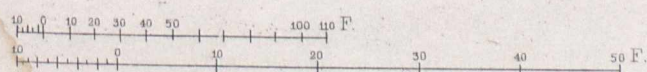
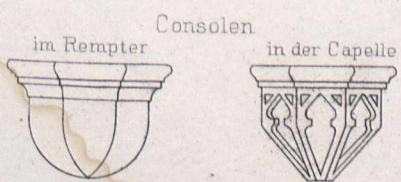
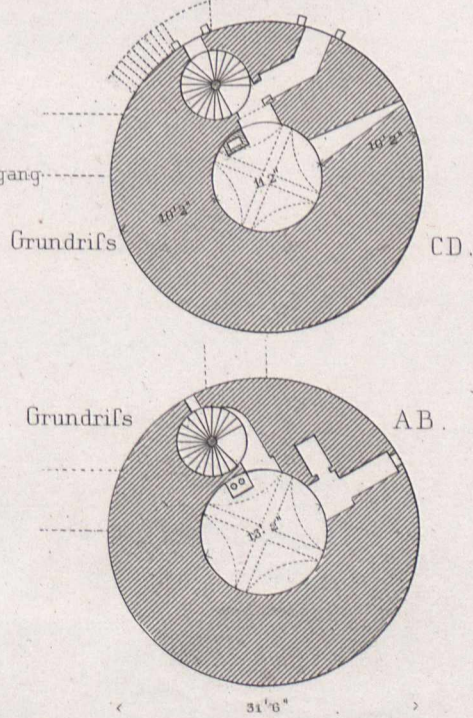
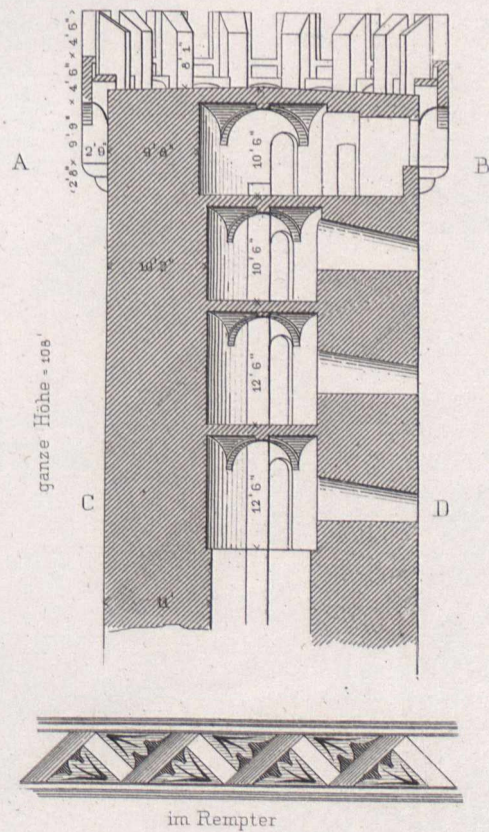

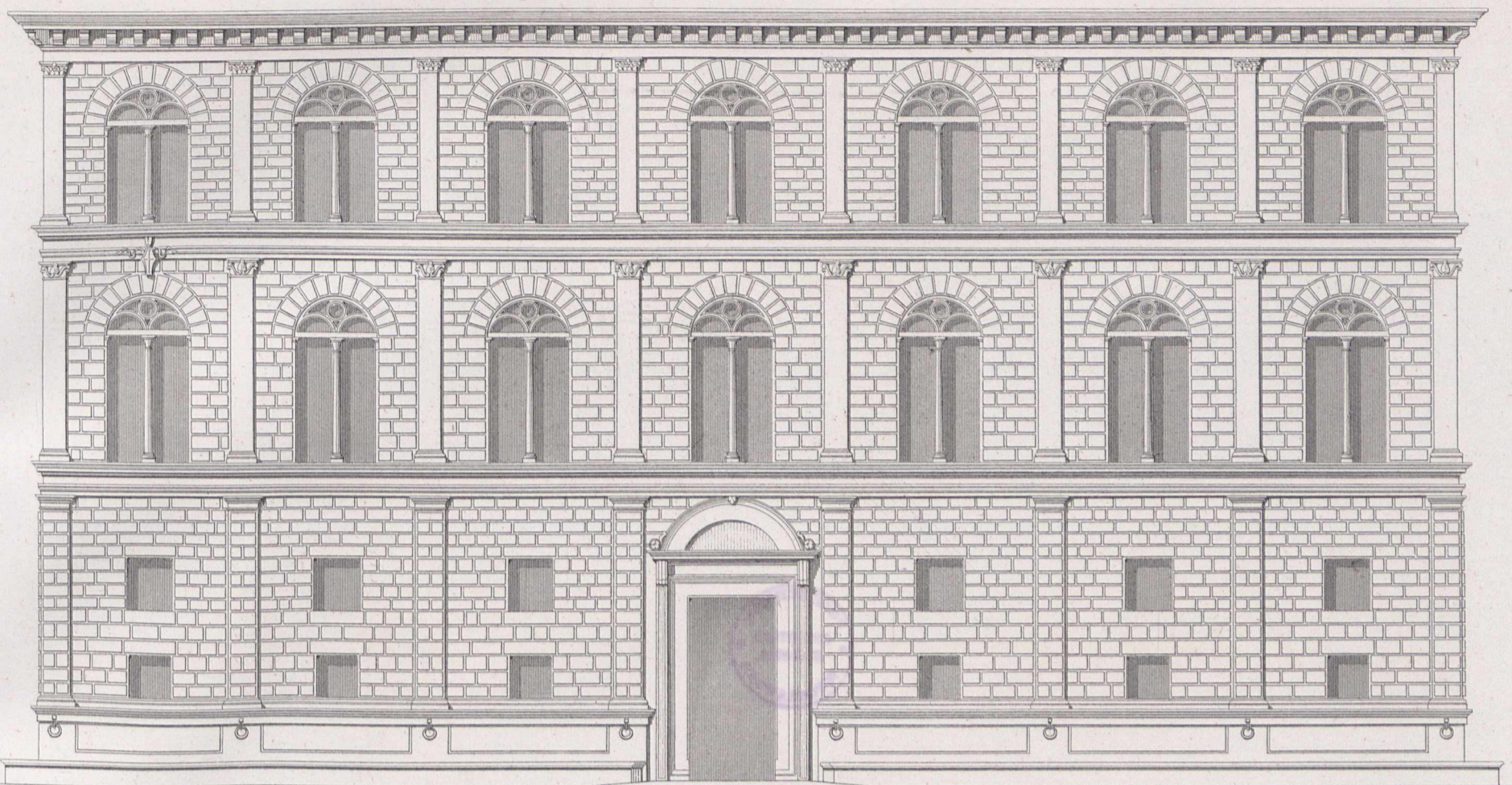

Palast Piccolomini

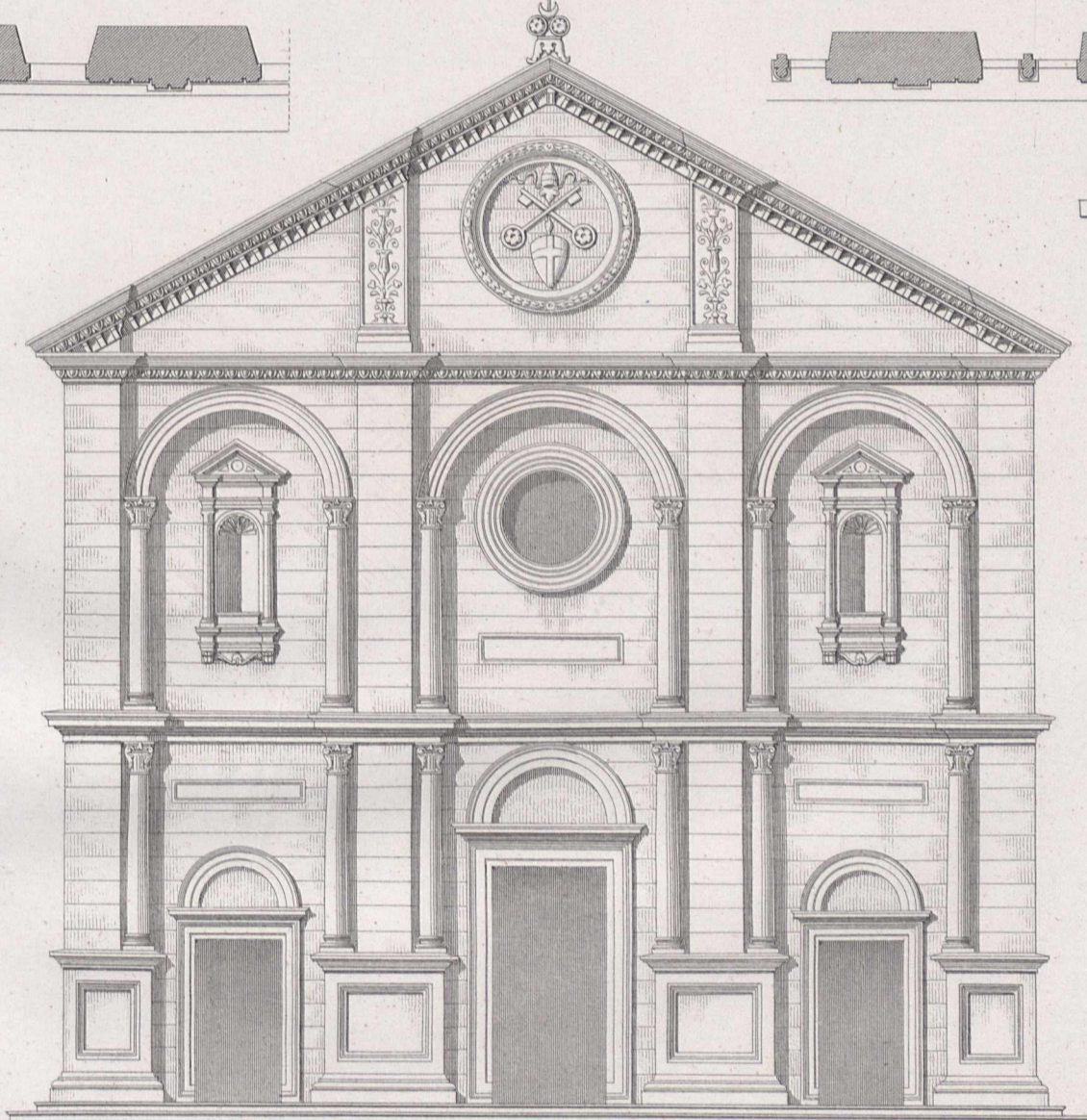
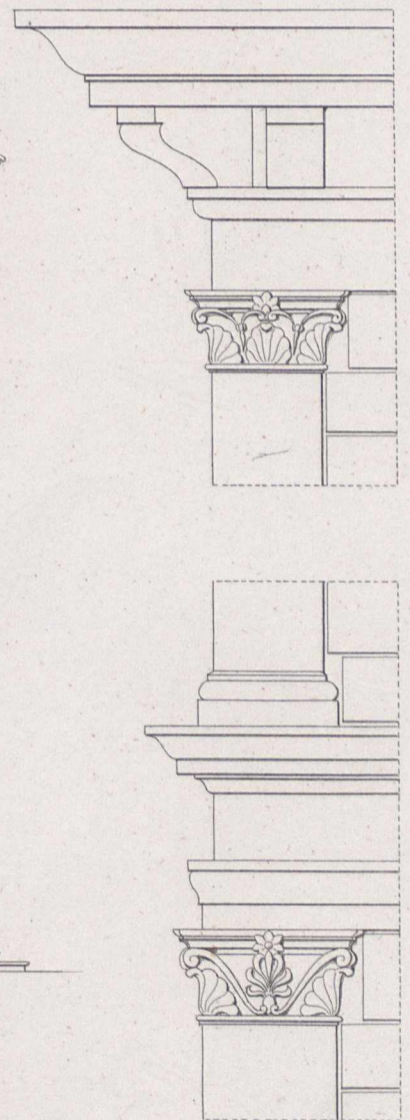
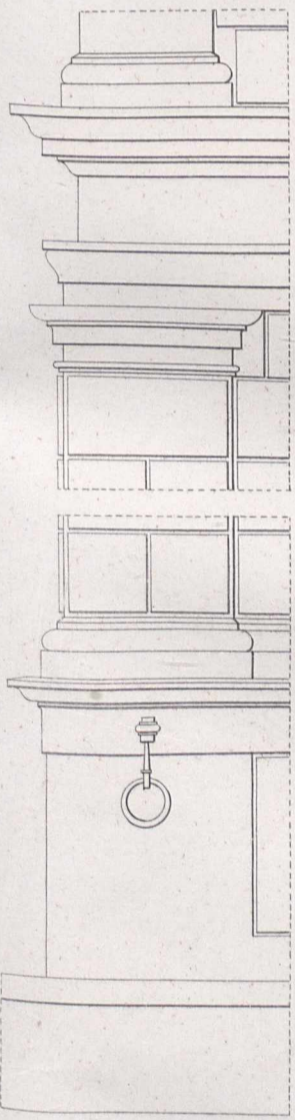
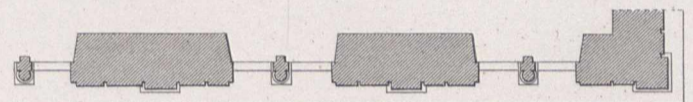
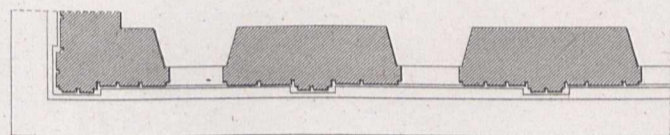

Dom.

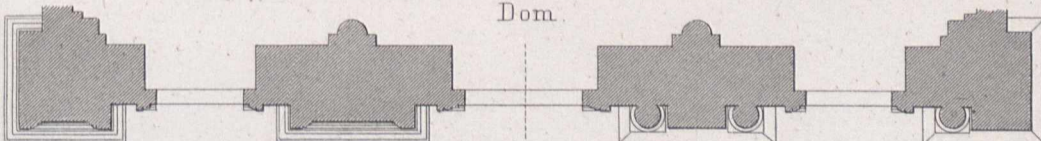

0 1 M

0 10 20 Meter

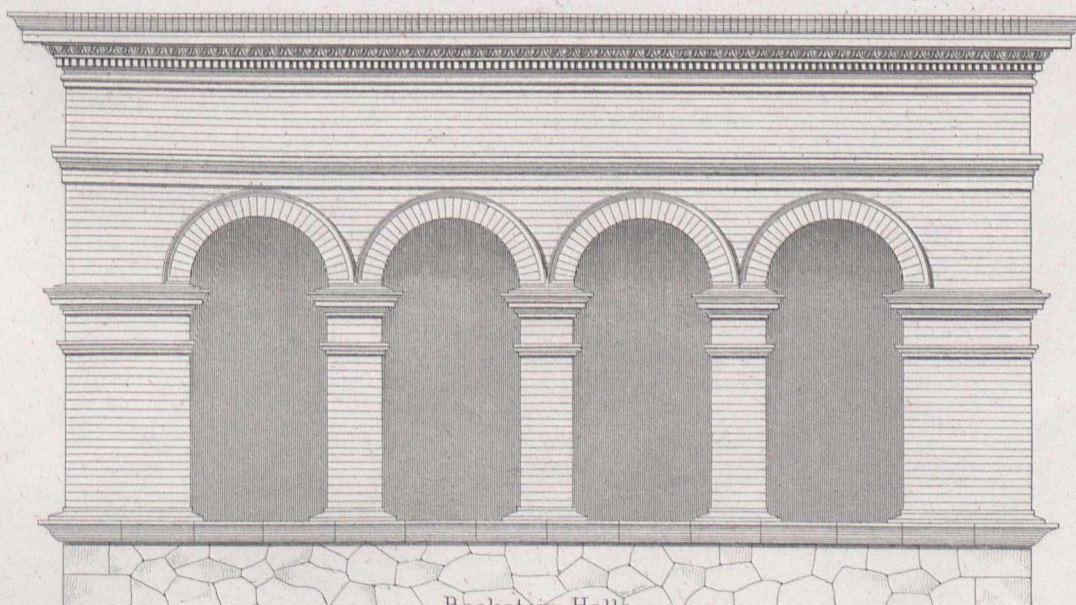
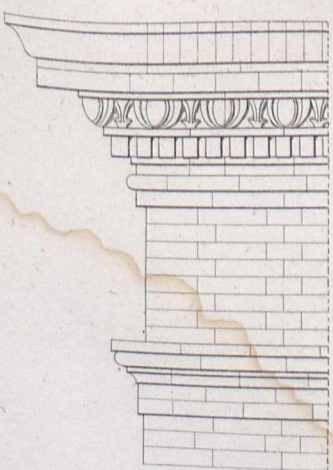

Backstein Halle

0 1 2 3 4 5 6 7 Meter

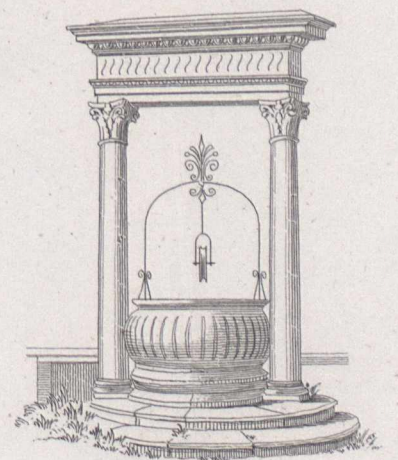

Ziehbrunnen