

Fourier transform holographic lenses

E. JAGOSZEWSKI

Institute of Physics, Technical University of Wrocław, Wybrzeże Wyspiańskiego 27, 50-370 Wrocław, Poland.

A review of the problems involved in designing optimal holographic optical elements for Fourier transform realization is presented. Just like conventional lenses, the Fourier transform holographic optical element should convert a finite set of input plane wave fronts into a finite set of output spherical wave fronts.

1. Introduction

Holographic optical elements being characterized by a definite structure of the interference fringes may be exploited to transform wave fronts, analogically to the conventional lenses of the corresponding aperture and the given field angle. In particular, such a role is played by an axial hologram of a point source created as a result of interference of two spherical waves. Different to the conventional optical elements, the holographic lens offers a possibility of aberration correction without employing any additional correcting elements in spite of the fact that the influence of its substrate geometry on the imaging properties is relatively small. In addition to economic aspects, the main advantages of holographic optical elements produced in thin layers of the recording medium are offered by their compact structure and small weight also in the case of great apertures.

The fundamental difference between the conventional and holographic optics is due to the fact that in the first case the basic role is played by refraction (or/and reflection) phenomena, while in the other — by diffraction. This means that the directions of the rays propagating in the image space depend upon the structure of the interference fringes of the hologram, while in the conventional optics — mainly upon the shapes of the surfaces and the refractive index of the imaging element. Consequently, the Snell's law is replaced by the generalized diffraction grating equation. Beside the diffraction efficiency characterizing the diffraction gratings of all types an essential role, in the case of holographic optical elements, is played by the imaging ability which is defined by the structure of the interference fringes and their distribution density.

Figure 1 illustrates the scheme of creation of an optical holographic element with the help of two coaxial spherical waves: a divergent wave emitted by the reference point source P_R and a wave convergent to the object point P_O . If the complex amplitudes of these waves in the plane of the recording medium are denoted by U_R and U_O , respectively, the hologram exposure being proportional to the squared modulus of the resultant amplitude takes the form

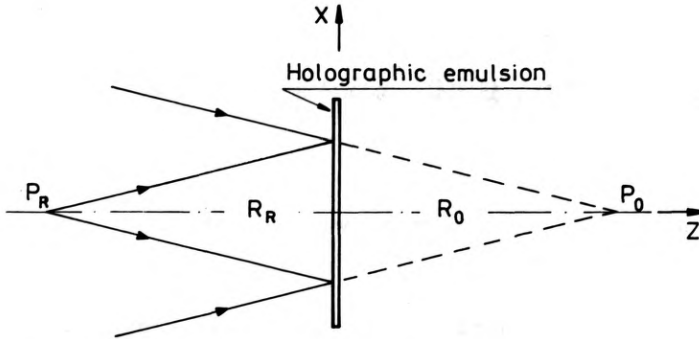

Fig. 1. Recording geometry of an axial symmetrical HOE by two spherical waves

$$(U_O + U_R)(U_O + U_R)^* \simeq 2[1 + \cos(\Phi_O - \Phi_R)] \tag{1}$$

where Φ_O and Φ_R are the phases of the object and reference waves, respectively, determined with respect to the hologram middle point. Equation (1) describes the distribution of the interference fringes creating the holographic optical element. In general, the amplitude transmittance of the hologram may be written in the form

$$T = \sum_{n=-\infty}^{\infty} T_n \exp[in(\Phi_O - \Phi_R)] \tag{2}$$

where n is the diffraction order. The holographic optical element created in this way may be used for the imaging purposes, for instance, of an off-axis point P_C shown in Fig. 2. The spherical wave emitted from the point P_C generates, after having been diffracted on the hologram plane, the image waves depending on the diffraction structure of the holographic optical element

$$I_n = T_n \exp\{i[\Phi_C + n(\Phi_O - \Phi_R)]\} = T_n \exp(i\Phi_{I_n})$$

where Φ_C is the phase of the wave incident on the holographic optical element, Φ_{I_n} is the phase of the image wave of n -th order immediately behind the holographic element.

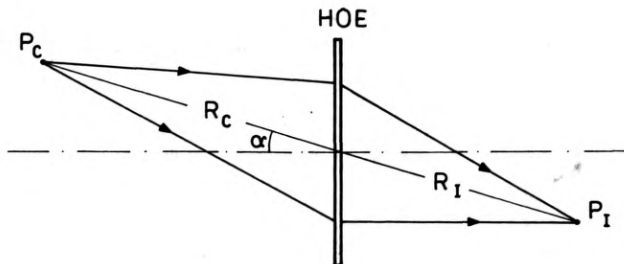

Fig. 2. Ray tracing in the holographic lens: from an off-axis point source P_C to its image point

Hence, the phase of the image wave of the first diffraction order has the form

$$\Phi_I = \Phi_C + (\Phi_O - \Phi_R). \quad (3)$$

On the other hand, if α_C denotes the incidence angle of the reconstructing wave falling on the holographic optical element, and α_I — the diffraction angle of this wave, the dependence between these angles is determined by the diffraction grating formula

$$d(\sin\alpha_C + \sin\alpha_I) = n\lambda_C. \quad (4)$$

The grating constant dependent on the structure of the interference fringes of the holographic optical element is determined with the help of the angles α_O and α_R which are created by the object and reference beams with the hologram axis, respectively. Thus

$$d = \frac{\lambda_O}{\sin\alpha_O + \sin\alpha_R}. \quad (5)$$

Comparing the expression (4) with the formula (5), we obtain the (diffraction grating) equation used frequently in holography which for the first order of diffraction takes the form

$$\sin\alpha_I = \frac{\lambda_C}{\lambda_O}(\sin\alpha_O + \sin\alpha_R) - \sin\alpha_C. \quad (6)$$

It is often used to describe the ray travelling through a holographic setup and to calculate the errors of holographic imaging. Representing the wave phases: Φ_O , Φ_R , Φ_C and Φ_I as being dependent on the spatial coordinates (x, y) and expanding them into power series in Eq. (3), we obtain the dependences determining the position of the meridional and sagittal foci with respect to the hologram

$$\frac{1}{R_I^{(s)}} = \frac{1}{f \cos^2 \alpha_C} - \frac{1}{R_C}, \quad \frac{1}{R_I^{(m)}} = \frac{1}{f} - \frac{1}{R_C} \quad (7)$$

where the focal length of the holographic element is defined by the formula

$$\frac{1}{f} = \frac{1}{R_O} + \frac{1}{R_R}. \quad (8)$$

The magnitudes R_O and R_R determine the positions of the object and reference points (sources), respectively, with respect to the middle point of the hologram during creation of the latter, while R_C defines the position of the point source which is imaged by the holographic lens. The angle α determines the slope angle of the chief ray of the light emitted from the imaged point (see Fig. 2).

2. Holographic Fourier transform

Holographic lenses may be exploited similarly to the conventional ones to image the points from the object to the image space. If the object transmittance is located in the

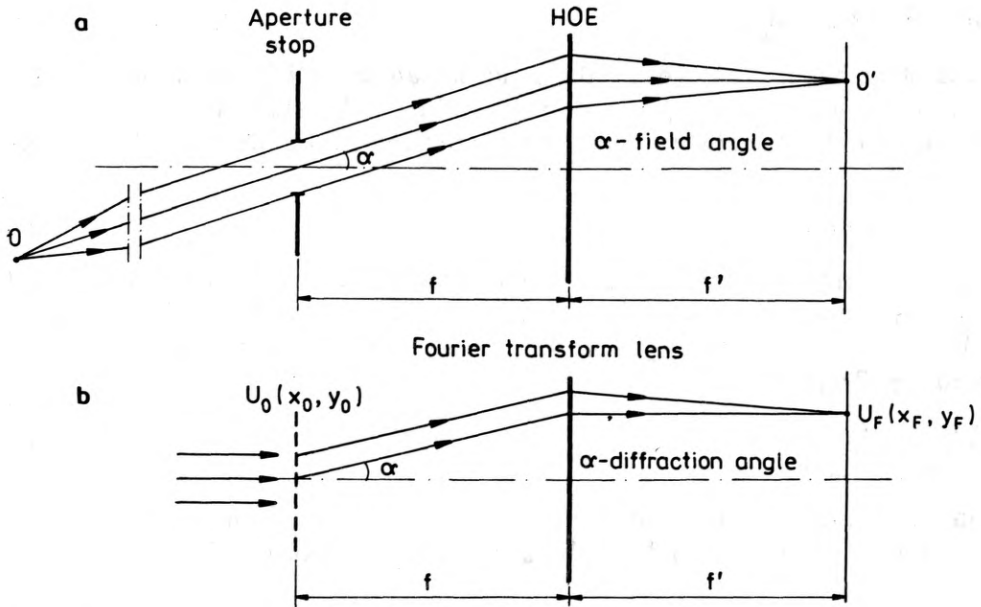

Fig. 3. Two equivalent holographic lens systems: a — for imaging an object from infinity to the image focal plane, b — for Fourier transform realization

first focal plane of the lens being illuminated by a collimated light beam, then the light distribution appearing in the back focal plane is a Fourier transform of the complex amplitude of the transmittance at the input of the system (Fig. 3b):

$$U_F(x_2, y_2) = \frac{i}{\lambda f} \iint_{-\infty}^{\infty} U_0(x_1, y_1) \exp \left[-i \frac{k}{f} (x_1 x_2 + y_1 y_2) \right] dx_1 dy_1, \quad (9)$$

where $k = \frac{2\pi}{\lambda}$ is the wave number. The above description of the diffraction phenomenon with the help of the Fourier integral (9) is true mainly for small diffraction angles. The realization of this kind of Fourier transform operation for large apertures and great diffracting angles is still possible in the imaging admitting higher values of distortion. This aim is especially easy to achieve in the case when the chief rays fulfil the sine condition in the optical system imaging stigmatically plane waves into spherical waves focused in the back focal plane of the optical system.

Analysing the ray trace in the system realizing the Fourier transform, we see that it is not an ordinary process of imaging the object into image points. If, however, the Abbe theory of image creation in a microscopic system is taken into account, it is possible to transform such a Fourier system into an equivalent one in which the known conventional laws of creating the images are applied (Fig. 3a). Under these circumstances the diffraction aperture is positioned in the front focal plane, and the off-axial object points located at infinity (the distance of which from the axis

determines the diffraction angles of the plane diffracted waves) are imaged into the back focal plane. This is because all the rays emitted from the light sources situated at infinity must pass through the aperture diaphragm deciding about the resolving power of the created images. This means that each wave emitted from an off-axial object point source localized at infinity corresponds to a diffracted plane wave representing a definite value of the spatial frequency of the object amplitude transmittance.

The imaging properties of the holographic lens are determined by the shape of the wave fronts used to produce that lens by employing the due interference effect in the light-sensitive layer of hologram. In general, the phase difference of those waves

$$\Phi_H(x, y) = \Phi_O(x, y) - \Phi_R(x, y) \quad (10)$$

is a phase function characterizing the focusing properties of the holographic element. On the other hand, for the light illuminating the holographic lens the phase of the wave at its output is

$$\Phi_{out}(x, y) = \Phi_{in}(x, y) + \Phi_H(x, y) \quad (11)$$

where $\Phi_{in}(x, y)$ is the phase of the wave incident on the holographic element. Thus, if a set of plane waves characterized by the functions $\Phi_{in}(x, y; \alpha)$ is given at the input of a holographic element and the set of required corresponding spherical waves of phases $\Phi_{out}(x, y; \alpha)$ is given at the output of this element, then, according to expression (11), we have the equation

$$\Phi_H(x, y; \alpha) = \Phi_{out}(x, y; \alpha) - \Phi_{in}(x, y; \alpha) \quad (12)$$

where α represents different values of the diffraction angle at the diffraction aperture. This means that for a given value of the diffracting angle α , the holographic lens of phase function $\Phi_H(x; \alpha)$ transforms perfectly the plane wave of phase $\Phi_{in}(x; \alpha)$ into spherical wave of phase $\Phi_{out}(x; \alpha)$. In general, the function $\Phi_H(x; \alpha)$ changes with the parameter α in such a way that the holographic element of function $\Phi_H(x) = \Phi_H(x; \alpha)$ images perfectly only for one value of the parameter α , while for the other values the imaging is charged with aberrations determined by the phase difference: $\Phi_H(x) - \Phi_H(x; \alpha)$. But the Fourier transform may be realized with the aid of the equivalent holographic lens, which is characterized by the property of aberration-free transformation of a set of plane waves into a corresponding set of spherical waves. Thus, the correction of aberration in the focal plane is carried out using, in most cases, the method of least squares, which consists in optimizing the holographic Fourier lens by minimizing the r.m.s. of the difference: $\Phi_H(x) - \Phi_H(x; \alpha)$ averaged within a definite interval of parameter α .

Thus, if a one-dimensional phase function of a holographic optical element defined by formula (10) is denoted by $\Phi_H(x)$ and the desired phase function of the examined optical element in accordance with the definition (12), by $\Phi_H(x; \alpha)$ the, r.m.s. error between the real and needed wave fronts is defined for an arbitrary value of the parameter α by the equation

$$E = \iint W(\alpha)P(x;\alpha)[\Phi_H(x) - \Phi_H(x;\alpha)]^2 d\alpha dx \quad (13)$$

where the pupil function $P(x;\alpha)$ may be used to determine the domain of integration. In general, $P(x;\alpha) = 1$ for all the points of a holographic element illuminated by a wave of parameter α , while for remaining points $P(x;\alpha) = 0$. The function $W(\alpha)$ is a weighting function changing the contribution of errors calculated with respect to the ideal wave front for waves of different values of parameter α . In all the cases it holds that

$$0 \leq W(\alpha) \leq 1.$$

The determination of the phase function $\Phi_H(x)$ of the examined holographic element requires the usage of the variational method. Namely, if there exists a variation of a functional $E[\Phi_H(x)]$ and it reaches the minimum for $\Phi_H = \Phi_h(x)$, then for $\Phi_H = \Phi_h(x)$ occurs $\delta E = 0$. Thus we have

$$\delta E = 2 \iint W(\alpha)P(x;\alpha)[\Phi_H(x) - \Phi_H(x;\alpha)]\delta\Phi_H(x)d\alpha dx$$

and

$$\int W(\alpha)P(x;\alpha)[\Phi_h(x) - \Phi_H(x;\alpha)]d\alpha = 0$$

for all the values of x . Hence, the optimized phase function of the holographic element takes the form

$$\Phi_h(x) = \frac{\int W(\alpha)P(x;\alpha)\Phi_H(x;\alpha)d\alpha}{\int W(\alpha)P(x;\alpha)d\alpha}. \quad (14)$$

Taking advantage of Eq. (12) and the considerations given above, we obtain for the needed ideal wave front $\Phi_{out}(x;\alpha)$ at the output of a holographic element

$$\Phi_h(x) = \frac{\int W(\alpha)P(x;\alpha)[\Phi_{out}(x;\alpha) - \Phi_{in}(x;\alpha)]d\alpha}{\int W(\alpha)P(x;\alpha)d\alpha}. \quad (15)$$

For the majority of the practical cases $\Phi_h(x)$ is a function being continuous across the domain, where $P(x;\alpha) = 1$. If it is assumed that the boundaries of the integration domain are functions of the variable x , i.e., $\alpha_1 = \alpha_1(x)$ and $\alpha_2 = \alpha_2(x)$, respectively, Eq. (15) takes the form

$$\Phi_h(x) = \frac{\int_{\alpha_1}^{\alpha_2} W(\alpha)[\Phi_{out}(x;\alpha) - \Phi_{in}(x;\alpha)]d\alpha}{\int_{\alpha_1}^{\alpha_2} W(\alpha)d\alpha}. \quad (16)$$

From the investigations reported in [2]–[5], it follows that the phase transfer function $\Phi_H(x,y)$ of the holographic element is optimal in the case when the r.m.s. error reaches minimum for all wave fronts at the output representing the particular spatial frequencies with the help of parameter α in a fixed interval $\alpha_1 \leq \alpha \leq \alpha_2$. The analysis of the function $\Phi_H(x,y)$ shows that it is not always possible to achieve small values of the r.m.s. error for all the values of parameter α , but in some particular

cases it is possible to obtain small (admissible) values of spherical aberration, coma, and astigmatism allowing relatively large distortion.

In works [2], [5], [9], devoted to the design of a holographic Fourier lens on a flat substrate, two kinds of imaging holographic elements are distinguished:

1. Spherical – created with the help of interference of two spherical wave fronts emitted from two differently localized point sources; *nota bene*, the plane wave is here considered also as a spherical wave of infinitely great radius of curvature (Fig. 1).

2. Aspherical – created with the help of wave fronts obtained from an auxiliary optical system or arbitrary wave fronts determined analytically (Fig. 4a,b).

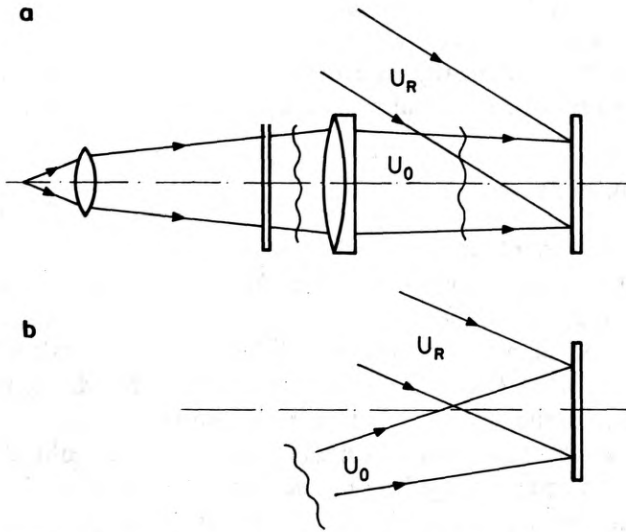

Fig. 4. Recording geometry of an aspheric HOE with an object aspheric wave front: a – derived from an auxiliary optical system, b – defined analytically

The problem of determination of both the phase and the directional cosines of the light rays belonging to the wave formed in the auxiliary optical system in order to produce a holographic optical element is not that simple for a fixed, in advance, trace of the reconstructing rays. The solution of the problem is based on the method of iteration and consists in exploitation of an auxiliary optical system to suitably direct the light rays in accordance with the ray-trace belonging to the reconstructing wave. For this purpose, a HOAD (Holographic Optics Analysis and Design) computer program is exploited which allows us to form an arbitrary wavefront necessary to record the aspheric holographic optical element. For the given amplitude of the wave, the task is reduced to recording the phase function of the wave front only on the surface of the light sensitive film which may be either of plane or curved shape. In general, the phase function of the recording wave is defined in the form of a power series

$$\Phi(x, y) = \sum_i \sum_j C_{ij} x^i y^j \quad (17)$$

or Legendre polynomial

$$\Phi(x, y) = \sum_i \sum_j C_{ij} L_i(x) L_j(y) \quad (18)$$

where the coefficients of the determined polynomial are the optimizing parameters, while their number may be as high as 100 for each phase function. Finally, if the recording wave is not attenuated its phase satisfies the condition

$$\left[\left(\frac{\partial \Phi}{\partial x} \right)^2 + \left(\frac{\partial \Phi}{\partial y} \right)^2 \right]^{1/2} \leq \frac{2\pi}{\lambda},$$

which is equivalent to the requirement that the sum of the squared directional cosines with respect to the x and y axes, respectively, be not greater than unity for λ denoting the recording wavelength. Analogically, in order to avoid the attenuation of the object wave the sum of its squared directional cosines must be less than unity.

3. HOE as a Fourier transform lens

The task of a holographic optical element (HOE) employed to realize the Fourier transform is to transform the set of plane waves inclined at different angles to the axis of the system, into a corresponding set of spherical waves convergent to their focal points located in the back focal plane of this element. Obviously, the creation of the Fourier holographic lens capable to transform a single plane wave of arbitrary inclination into a needed convergent spherical wave is relatively simple. However, in the case of a number of plane waves diffracted at different angles by the object examined, an optimizing procedure must be applied to the phase function of the holographic element (lens). As it was shown in the former section, the problem is reduced to the minimization of the r.m.s. between the spherical and the corresponding actual wave fronts at the output of the system. In general, the object transmittance located in the front focal plane of the lens and illuminated by a plane wave of coherent light generates an angular spectrum of plane waves, each of which represents a corresponding spatial frequency of the transmittance (defined by its diffraction angle). All these waves are focused, depending on the diffraction angles, by the lens at characteristic points localized in its back focal plane. The object transmittance of high spatial frequencies is characterized by the fact that the illuminating wave is diffracted at high angles, due to which the focusing of waves occurs proportionally at the greater distances from the axis.

Holographic lenses produced initially were spherical lenses created in a conventional way by using the spherical wave fronts. Such lenses can be applied only within the region of small diffraction angles. They are often a starting point for recording the holographic optical elements applied to examine the spatial frequency spectrum in a broader interval. In Figure 4a, a scheme is shown for recording an aspherical holographic lens with the help of a plane reference wave and a deformed spherical wave emitted from the point source located on the axis perpendicular to the recording medium. Figure 5 illustrates the creation of an aspheric lens with the

help of a spherical wave and commonly used plane reference wave to which a perturbation is introduced determined by the phase transfer function in the form of a polynomial

$$\Phi(x,y) = \frac{2\pi}{\lambda} [C_{20}x^2 + C_{40}x^4 + C_{60}x^6 + C_{80}x^8 + C_{02}y^2 + C_{04}y^4 + C_{06}y^6 + C_{08}y^8 + C_{22}x^2y^2 + C_{44}x^4y^4]. \quad (19)$$

One of the commonly applied methods of producing an aspheric holographic element is the recording of the wave front suitably created with the help of computer-generated hologram (CGH). The amplitude transmittance of such a hologram is reduced to the form

$$t_A(x,y) = B + A(x,y)\cos[\omega x + \Phi(x,y)], \quad (20)$$

where: $B \approx 0.5$ is an averaged value of transmittance,

$A(x,y) \leq 0.5$ – amplitude,

ω – carrier frequency of the reference wave,

$\Phi(x,y)$ – phase transfer function defined by formula (19).

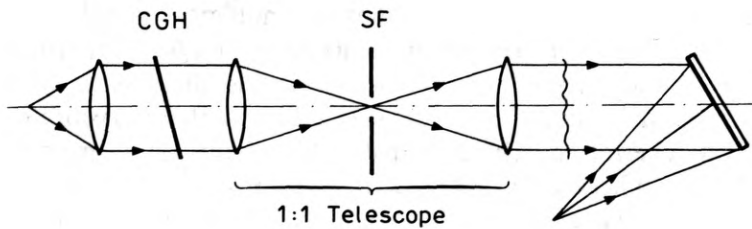

Fig. 5. Geometry of recording an aspheric Fourier transform holographic lens by using an aspheric reference wave front. CGH – computer generated hologram, SF – spatial filter

In Figure 5, the optical system for recording such aspheric Fourier lens known as Computer Originated Holographic Optical Element (COHOE) is presented. In this system, the wave front diffracted on the CGH and imaged into recording medium (COHOE) with the help of a telescope system of unit magnification preserves the requested phase relations. The spatial filter is located in the spatial frequency plane in such a way that only the first order diffraction wave diffracted by the hologram CGH passes through the filter, going next to the plane of the recording medium. The planes of CGH and COHOE being inclined are optically conjugated, while their inclination assures simultaneously the needed inclination of the reference wave during recording. The recording of the optimized holographic Fourier element is thus reduced to the exploitation of both the phase of the ideal spherical wave emitted from the point source

$$\Phi_0(x,y) = \frac{2\pi}{\lambda} [(x^2 + y^2 + f^2)^{1/2}], \quad (21)$$

and the phase of the corrected wave generated from CGH instead of the plane reference wave, as shown in Fig 5. In accordance with the procedure of minimizing the r.m.s. error the corresponding changes of the coefficients C_{ij} lead to optimization of the aspheric Fourier lens. The ray-trace calculations carried out by FAIRCHILD and FIENUP [2] for the rays in two planes perpendicular with respect to each other (ten different incidence angles for each) gave the optimized values of the coefficients C_{ij} , which are presented in the Table.

Table. Optimized coefficients of the aspheric Fourier lens

$C_{20} = 0.714$	$C_{40} = 4.092$	$C_{60} = 3.150$	$C_{80} = -0.964$
$C_{02} = 1.569$	$C_{04} = 2.194$	$C_{06} = 4.036$	$C_{08} = 0.502$
$C_{22} = 1.908$	$C_{44} = 64.619$		

The recording of the holographic Fourier lens of the focal length $f = 50$ cm was performed using the light of the wavelength $\lambda = 514.5$ nm. The coefficients in the Table were normalized under assumption of unity wavelength and scaling of the hologram coordinates within the border of the recording surface $-1 \leq (x, y) \leq 1$. The quality of the images was compared with the aberrations of spherical holographic lens for different incidence angles for chief rays falling on the hologram [2]. The analysis of the image qualities showed that the holographic spherical element has, in principle, no spherical aberration, while its coma and field curvature are high. In spite of this, the aspherical holographic element is characterized by a distinctly reduced coma and field curvature which were achieved at the expense of introducing some spherical aberration. The maximal value of the r.m.s. error is reduced from 0.297λ for the spherical element down to 0.038λ for the aspheric holographic element. The optimization of the holographic aspheric element carried out in this work had no influence on the reduction of distortion which under these circumstances was not the subject of investigation.

4. Telecentric setup

One of the optical systems used to reduce efficiently the distortion is the telecentric system in which the aperture stop located in the front focal plane of the lens is imaged in the exit pupil plane located at infinity. In such systems the chief rays passing through the middle of the entrance pupil, in the image space are parallel to the optical axis of the system. This means that they are perpendicular to the image plane, any shift of which has no influence on the mutual localization of the image points representing the spatial frequencies of the examined transmittance. The simplest example of such a lens is a Fresnel zone plate or an equivalent hologram of the axial point created as a result of interference of a spherical wave with the plane one as it is shown in Fig. 6. These waves are emitted from two point sources of monochromatic light positioned on the axis of the system: the reference source — at infinity, the object source — at the distance f from the plane of the recording medium. The phase transfer function of the created

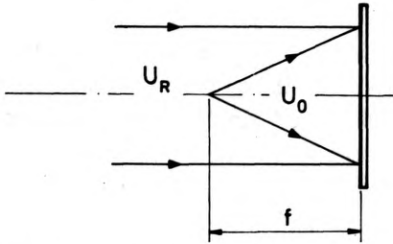

Fig. 6. Recording of a spherical HOE of the focal length f . FP – Fourier plane

holographic element is dependent above all on the recording spherical wave defined by Eq. (21).

In Figure 7, the ray trace in a telecentric configuration of the holographic Fourier lens is shown. The plane wave falling at an arbitrary angle α may be transformed into a spherical wave by the holographic lens characterized by the phase transfer function of the following form:

$$\Phi_H(x) = \frac{2\pi}{\lambda} \{ [(x-x_a)^2 + f^2]^{1/2} - (x-x_a)\sin\alpha \} \tag{22}$$

where $x_a = f \tan\alpha$ is a coordinate of the intersection point of the chief ray with the plane of the lens. Comparing Eq. (22) with the one-dimensional equation (21), we see that the transformation of the plane waves into the desired ideal wavefronts occurs in two particular cases:

1. When $\alpha = 0$, then $x_a = 0$, i.e., the plane wave falling perpendicularly on the Fourier lens is transformed into the spherical wave.
2. If infinitesimally narrow bundle of light rays passes under the angle $\alpha \neq 0$ through the centre of the entrance pupil, it propagates, after having been transformed, parallelly to the optical axis; it is always represented by its chief ray, which passes through the centre of the aperture stop that is identical with the focus of the lens in a telecentric system.

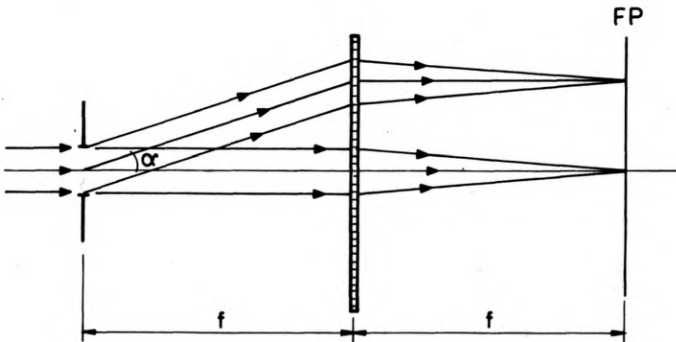

Fig. 7. Ray tracing in the parallel beam Fourier transform

Telecentric configuration of rays is, generally, exploited for measurement of mutual localization of the image points with high accuracy, and therefore the telecentric system realizing the Fourier transform leads to reduction of the position error of the image points representing the spatial frequencies of the definite spectrum.

Holographic Fourier lenses creating images of high quality in the Fourier plane must fulfil not only the condition for aplanatism and an astigmatism, but and above all, the chief rays must satisfy the sine condition for all the field angles. The analysis of the ray trace in a holographic optical element produced on a plane substrate indicates that the distance from the optical axis of the image point representing the spatial frequency is defined by the formula: $x_\alpha = f \tan \alpha$, while α is the field angle of the given chief ray. But for the holographic Fourier lens fulfilling the Abbe' sine condition we have: $x_\alpha = f \sin \alpha$ which can be realized only with the help of a holographic element on spherical substrate. In this case, the centre of curvature of the spherical substrate covers the focus of the lens which results in a distinct reduction of coma.

5. Converging beam Fourier transform

The converging beam Fourier transform lens employs the diffraction of converging spherical waves by the transparent object, as shown in Fig. 8. In this case, the object is inserted behind the holographic lens that produces a perfectly spherical wave [10], *i.e.*, it should be corrected for spherical aberration. If the lens is illuminated by a normally incident plane wave of amplitude A , then a spherical wave is incident on the object which after diffraction gives a field distribution across the focal plane described by the Fourier transform of the object transparency

$$U_F(x_2, y_2) = \frac{A \exp \left[i \frac{k}{2d} (x_2^2 + y_2^2) \right]}{i \lambda d} \iint_{-\infty}^{\infty} U_O(x_1, y_1) \exp \left[-\frac{k}{d} (x_1 x_2 + y_1 y_2) \right] dx_1 dy_1. \quad (23)$$

Thus, up to a quadratic phase factor the field distribution in the back focal plane is the Fourier transform of that portion of the object subtended by the projected

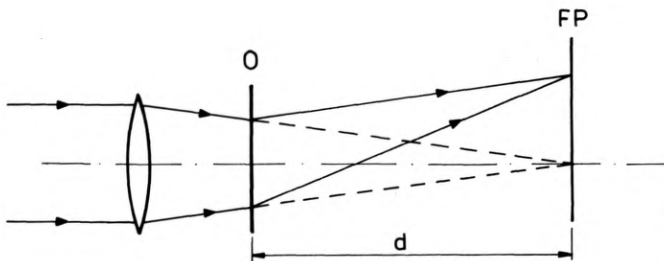

Fig. 8. Ray tracing in the converging beam Fourier transform system. O — object with a frequency component

lens aperture at the spatial frequencies:

$$\omega_x = \frac{2\pi x_F}{\lambda d}, \quad \omega_y = \frac{2\pi y_F}{\lambda d}. \quad (24)$$

We see that when increasing the distance d , the spatial size of the transform is increased, and when decreasing d the transform size becomes smaller. Independently of the corrected spherical wave for an on-axis point, aberrations are induced by this wave owing to the diffraction at the object. But, we must remember that the following basic conditions must be fulfilled always in the Fourier plane: i) the quality of the focused spots at all locations corresponding to different diffraction angles should be the same, and ii) the spots should occur at coordinates which are proportional to the frequency components of the object. Therefore, it is important to know quantitatively the induced aberrations in each particular case. If a linear holographic grating is inserted in the object plane instead of the object, then by using the Meier's formula of the third-order holographic aberrations the wave front deviation in 1-D takes the form

$$\Delta = \Delta_S + \Delta_C + \Delta_A + \Delta_F \quad (25)$$

where the wave front deviation owing to spherical aberration $\Delta_S = 0$, and:

$$\Delta_C = -\frac{x_F}{2d^3} R^3 \cos\theta, \quad \Delta_A = \frac{x_F^2}{2d^3} R^2 \cos^2\theta, \quad \Delta_F = \frac{x_F^2}{4d^3} R^2$$

are the wavefront deviations owing to coma, astigmatism and field curvature, respectively. The polar coordinates (R, θ) are determined in the exit pupil of the system, where the angle θ is formed by R with the positive y -direction. The fifth aberration, *i.e.*, distortion yields only a shift of image in the Fourier plane. Analysing the aberrations of the converging beam Fourier transform setup it appears that it is a better solution especially for the limited range of both spatial frequency and object size. Such a system is much simpler than the conventional one, being also easier to implement [11]–[13].

6. Conclusions

Beside the aspheric holographic lenses being applied to Fourier transform implementation, the spherical holographic lenses attract some interest as well. Especially interesting are relatively simple axial holographic lenses produced on the spherical substrate and operating in a telecentric run of the light rays in the image space. Solutions of that kind have a significant influence particularly on the reduction of distortion and coma, the elimination of which is assured when the sine condition is fulfilled. On the other hand, the Fourier transform system based on diffraction of spherical wave is a simple and cheap version, and should be applied in a number of cases, especially when spatial frequency range is limited.

References

- [1] FIENUP J. R., LEONARD C. D., *Appl. Opt.* **18** (1979), 631.

- [2] FAIRCHILD R. C., FIENUP J. R., *Opt. Eng.* **21** (1982), 133.
- [3] WINNICK K. A., FIENUP J. R., *J. Opt. Soc. Am.* **73** (1983), 208.
- [4] KEDMI J., FRIESEM A. A., *Appl. Opt.* **23** (1984), 4015.
- [5] CEDERQUIST J. N., FIENUP J. R., *J. Opt. Soc. Am. A* **4** (1987), 699.
- [6] AMITAI Y., FRIESEM A. A., *J. Opt. Soc. Am. A* **5** (1988), 702.
- [7] ASSENHEIMER M., AMITAI Y., FRIESEM A. A., *Appl. Opt.* **27** (1988), 4747.
- [8] AMITAI Y., FRIESEM A. A., *Opt. Lett.* **13** (1988), 833.
- [9] JAGOSZEWSKI E., *Optik* **83** (1989), 151.
- [10] JOYEUX D., LOWENTHAL S., *Appl. Opt.* **21** (1982), 4368.
- [11] JAGOSZEWSKI E., *Holographic focusing elements for Fourier transform systems*, Proc. SPIE, in print.
- [12] SULTANOVA N., KASPRZAK H., *Optik* **67** (1984), 155.
- [13] KASPRZAK H., SULTANOVA N., PODBIELSKA H., *J. Opt. Soc. Am. A* **4** (1987), 843.

Received October 12, 1993